

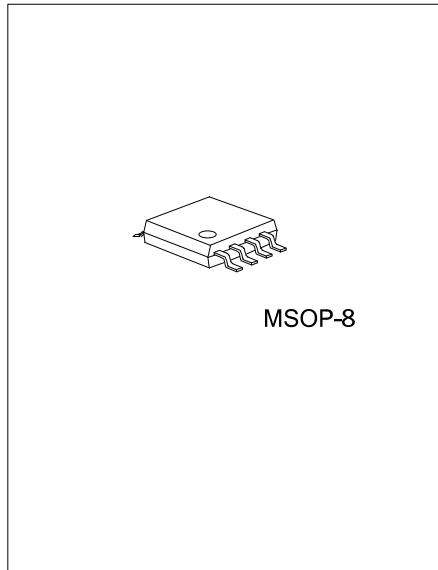

LI-ION BATTERY PROTECTION IC FOR 1-CELL TO 4-CELL PACK (SECONDARY PROTECTION)



DESCRIPTION

The UTC **UB244A** Series is secondary protection IC for 1-, 2-, 3-, or 4-Cell lithium-ion rechargeable battery packs, and incorporates a high-accuracy voltage detection circuit.

The UTC **UB244A** Series also includes a high accuracy delay circuit for over voltage detection time can be set by an external capacitor.

FEATURES

- * High-accuracy voltage detection circuit for each cell
- * Overcharge detection voltage n (n=1 to 4): 4.05V to 4.50V (in 50mV steps)
- * Overcharge hysteresis voltage n (n=1 to 4): 0.38V±0.10V, 0.25V±0.07V, 0.13V±0.04V, 0.045V±0.02V, None
- * Delay times for overcharge detection can be set by an external capacitor
- * CMOS output active "H"
- * Wide operating voltage range 3.6V to 24V
- * Wide operating temperature range -40°C to +85°C
- * Low current consumption: 1.5µA typ. (+25°C) at 3.5V for each cell

ORDERING INFORMATION

Ordering Number		Package	Packing
Lead Free	Halogen Free		
UB244AL-xx-SM1-R	UB244AG-xx-SM1-R	MSOP-8	Tape Reel

Note: xx: Output Voltage, refer to Marking Information.

<p>UB244AG-xx-SM1-R</p> <p>(1)Packing Type (2)Package Type (3)Output Voltage Code (4)Halogen Free</p>	<p>(1) R: Tape Reel (2) SM1: MSOP-8 (3) xx: Refer to Marking Information (4) G: Halogen Free, L: Lead Free</p>
---	--

■ PIN CONFIGURATION

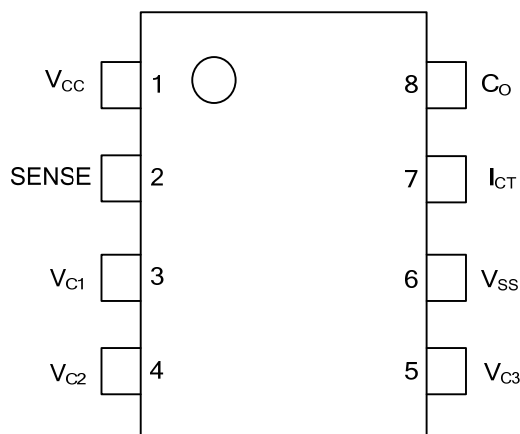

■ PIN DESCRIPTION

PIN NO.	PIN NAME	DESCRIPTION
1	V _{CC}	Positive power input pin
2	SENSE	Positive voltage connection pin of battery 1
3	V _{C1}	Negative voltage connection pin of battery 1 Positive voltage connection pin of battery 2
4	V _{C2}	Negative voltage connection pin of battery 2 Positive voltage connection pin of battery 3
5	V _{C3}	Negative voltage connection pin of battery 3 Positive voltage connection pin of battery 4
6	V _{SS}	Negative power input pin Negative voltage connection pin of battery 4
7	I _{CT}	Capacitor connection pin for overcharge detection delay
8	C _O	FET gate connection pin for charge

■ SERIAL CODE LIST

MODEL	CODE	OVERCHARGE DETECTION VOLTAGE [V _{CU}](V)	OVERCHARGE HYSTERSIS VOLTAGE [V _{CD}](V)	OUTPUT FORM
UB244A	AA	4.450±0.050	0.380±0.10	CMOS output active "H"
	AB	4.115±0.050	0.130±0.04	CMOS output active "H"
	AC	4.350±0.050	0.045±0.02	CMOS output active "H"
	AD	4.450±0.050	0.045±0.02	CMOS output active "H"
	AE	4.300±0.050	0.250±0.07	CMOS output active "H"
	AF	4.400±0.050	0.045±0.02	CMOS output active "H"
	AG	4.500±0.050	0.380±0.10	CMOS output active "H"
	AH	4.475±0.050	0.380±0.10	CMOS output active "H"
	AI	4.350±0.050	0.250±0.07	CMOS output active "H"
	AJ	4.150±0.050	0.250±0.07	CMOS output active "H"
	AK	4.250±0.050	0.250±0.07	CMOS output active "H"
	AL	4.050±0.050	0.250±0.07	CMOS output active "H"

■ BLOCK DIAGRAM

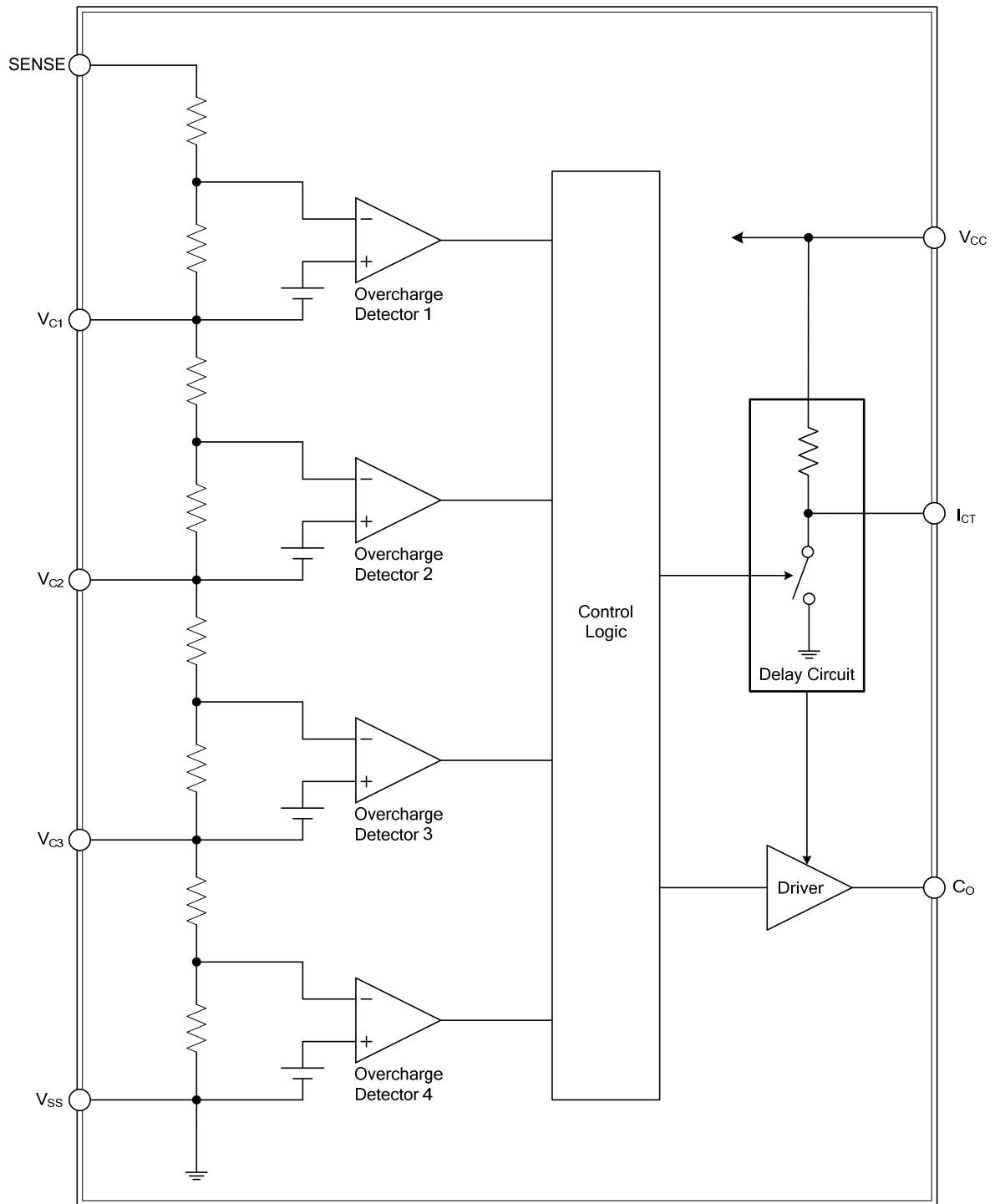

■ ABSOLUTE MAXIMUM RATING ($T_A=25^{\circ}\text{C}$ unless otherwise specified)

PARAMETER	SYMBOL	RATINGS	UNIT
Input Voltage Between V_{CC} And V_{SS}	V_{DS}	$V_{SS}-0.3 \sim V_{SS}+26$	V
Input Pin Voltage (SENSE/ V_{C1} / V_{C2} / V_{C3})	V_{IN}	$V_{SS}-0.3 \sim V_{CC}+0.3$	V
CO Output Pin Voltage	V_{CO}	$V_{SS}-0.3 \sim V_{CC}+0.3$	V
Power Dissipation (Note 2)	P_D	500	mW
Operation Ambient Temperature	T_{OPR}	$-40 \sim +85$	$^{\circ}\text{C}$
Storage Temperature	T_{STG}	$-40 \sim +125$	$^{\circ}\text{C}$

Notes: 1. Absolute maximum ratings are those values beyond which the device could be permanently damaged. Absolute maximum ratings are stress ratings only and functional device operation is not implied.
2. When mounted on printed circuit board.

■ ELECTRICAL CHARACTERISTICS ($T_A=25^{\circ}\text{C}$ unless otherwise specified)

PARAMETER	SYMBOL	TEST CONDITIONS	MIN	TYP	MAX	UNIT
DETECTION VOLTAGE						
Overcharge Detection Voltage n (n = 1, 2, 3, 4)	V_{CU_n}	4.05V ~ 4.50V Adjustment	$V_{CU_n} - 0.050$	V_{CU_n}	$V_{CU_n} + 0.050$	V
Overcharge Hysteresis Voltage n (n = 1, 2, 3, 4) (Note 1)	V_{CD_n}		0.28	0.38	0.48	V
DELAY TIME						
Overcharge Detection Delay Time	t_{CU}	C=0.1 μF	1.0	1.5	2.0	S
OPERATING VOLTAGE						
Operating Voltage Between V_{CC} And V_{SS} (Note 2)	V_{DSOP}		3.6		24	V
CURRENT CONSUMPTION						
Current Consumption During Operation	I_{OPE}	V1=V2=V3=V4=3.5V		1.5	6.0	μA
Current Consumption At Power Down	I_{PDN}	V1=V2=V3=V4=2.3V		1.2	6.0	μA
VC1 Pin Current	I_{VC1}	V1=V2=V3=V4=3.5V	-0.5	0	0.5	μA
VC2 Pin Current	I_{VC2}	V1=V2=V3=V4=3.5V	-0.5	0	0.5	μA
VC3 Pin Current	I_{VC3}	V1=V2=V3=V4=3.5V	-0.5	0	0.5	μA
OUTPUT VOLTAGE						
CO "H" VOLTAGE	$V_{CO(H)}$	$I_{OUT} = -10\mu\text{A}$	$V_{CC} - 0.05$			V
CO "L" VOLTAGE	$V_{CO(L)}$	$I_{OUT} = 10\mu\text{A}$			VSS + 0.05	V

Notes: 1. $0.25 \pm 0.07\text{V}$, $0.13 \pm 0.04\text{V}$, $0.045 \pm 0.02\text{V}$ except for 0.38V hysteresis models.
2. After detecting the overcharge, the delay circuit operates normally in the range of operating voltage.

■ OPERATING

1. Overcharge Detection

CO is turned to “H” (for CMOS output active “H”) when the voltage of one of the batteries exceeds the overcharge detection voltage (V_{CU}) during charging under normal conditions beyond the overcharge detection delay time (t_{CU}). This state is called “overcharge.” Attaching FET to the CO pin provides charge control and a second protection. At that time, the overcharge state is maintained until the voltage of all batteries decreases from the overcharge detection voltage (V_{CU}) by the equivalent to the overcharge hysteresis voltage (V_{CD}).

2. Delay Circuit

The overcharge detection delay time (t_{CU}) change with an external capacitor (C_{ICT}). The delay times are calculated by the following equations:

Overcharge detection delay time $t_{CU}[s] = (15 \pm 5) \times C_{ICT} [\mu F]$

■ TIMING CHARTS

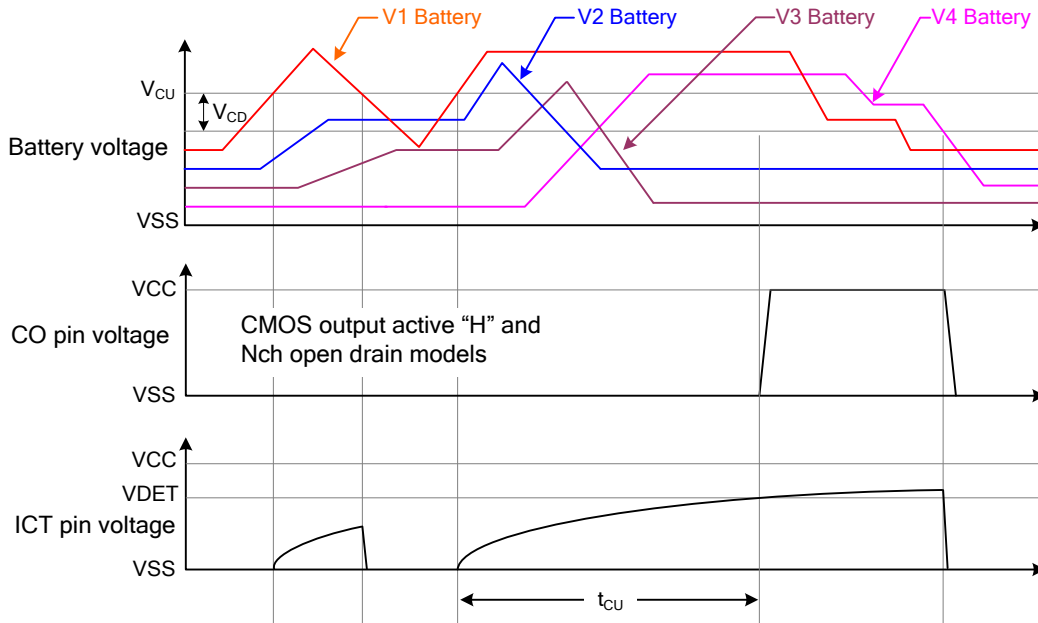

■ TYPICAL APPLICATION CIRCUIT

(1) Connection Example 1 (for 4-cells)

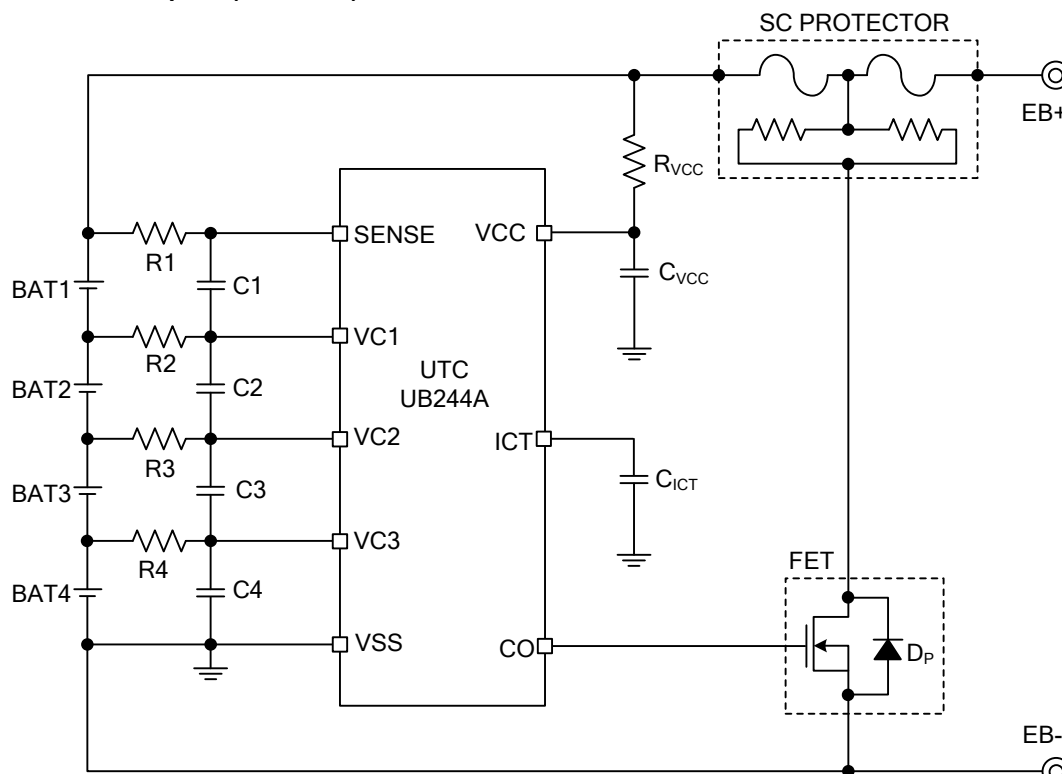

Constants for External Components 1

SYMBOL	MIN	TYP	MAX	UNIT
R1 to R4	0	1 k	10 k	Ω
C1 to C4	0	0.1	1	μF
R_{vcc}	0	100	1 k	Ω
C_{vcc}	0	0.1	1	μF
C_{ict}	0	0.1	1	μF

- Notes:
1. The above constants may be changed without notice.
 2. It has not been confirmed whether the operation is normal or not in circuits other than the above example of connection. In addition, the example of connection shown above and the constant do not guarantee proper operation. Perform through evaluation using the actual application to set the constant.

■ TYPICAL APPLICATION CIRCUIT(Cont.)

(2) Connection Example 2 (for 4-cells)

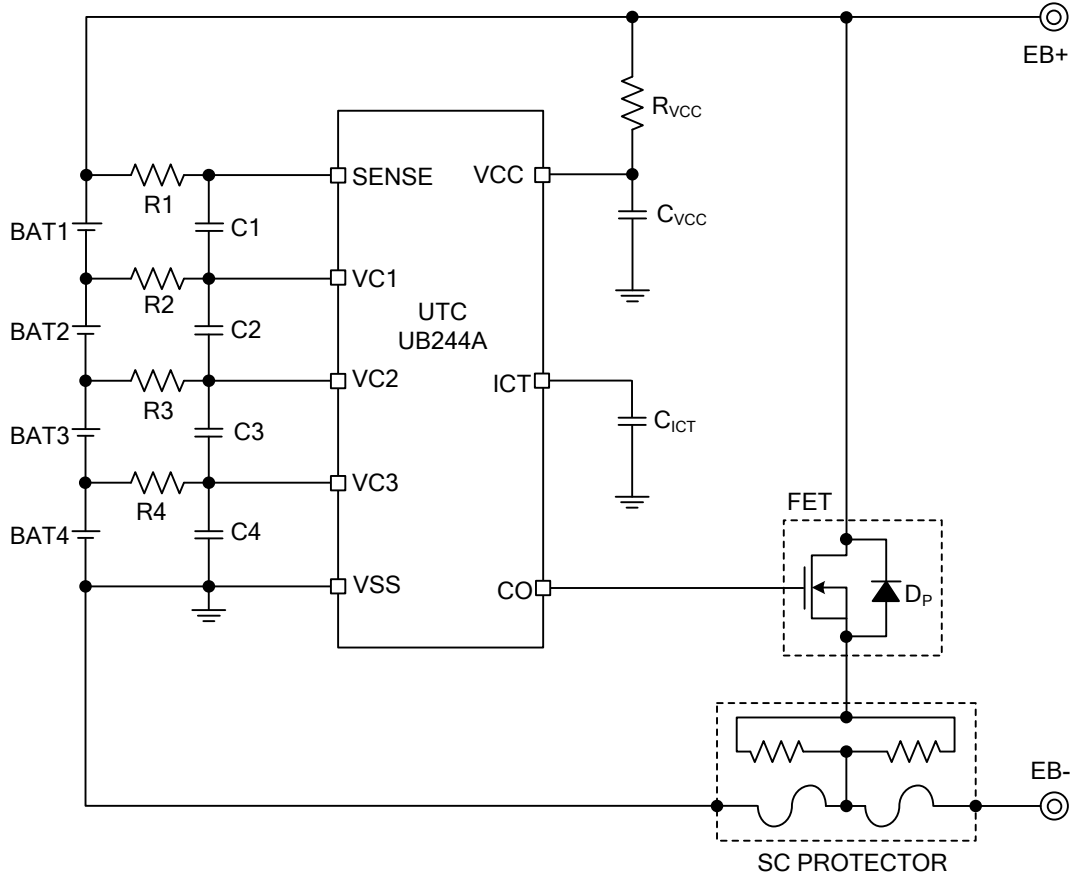

Constants for External Components 2

SYMBOL	MIN	TYP	MAX	UNIT
R1 to R4	0	1 K	10 k	Ω
C1 to C4	0	0.1	1	μF
R _{vcc}	0	100	1 k	Ω
C _{vcc}	0	0.1	1	μF
C _{ict}	0	0.1	1	μF

- Notes:
1. The above constants may be changed without notice.
 2. It has not been confirmed whether the operation is normal or not in circuits other than the above example of connection. In addition, the example of connection shown above and the constant do not guarantee proper operation. Perform through evaluation using the actual application to set the constant.

■ TYPICAL APPLICATION CIRCUIT(Cont.)

(3) Connection Example 3 (for 3-cells)

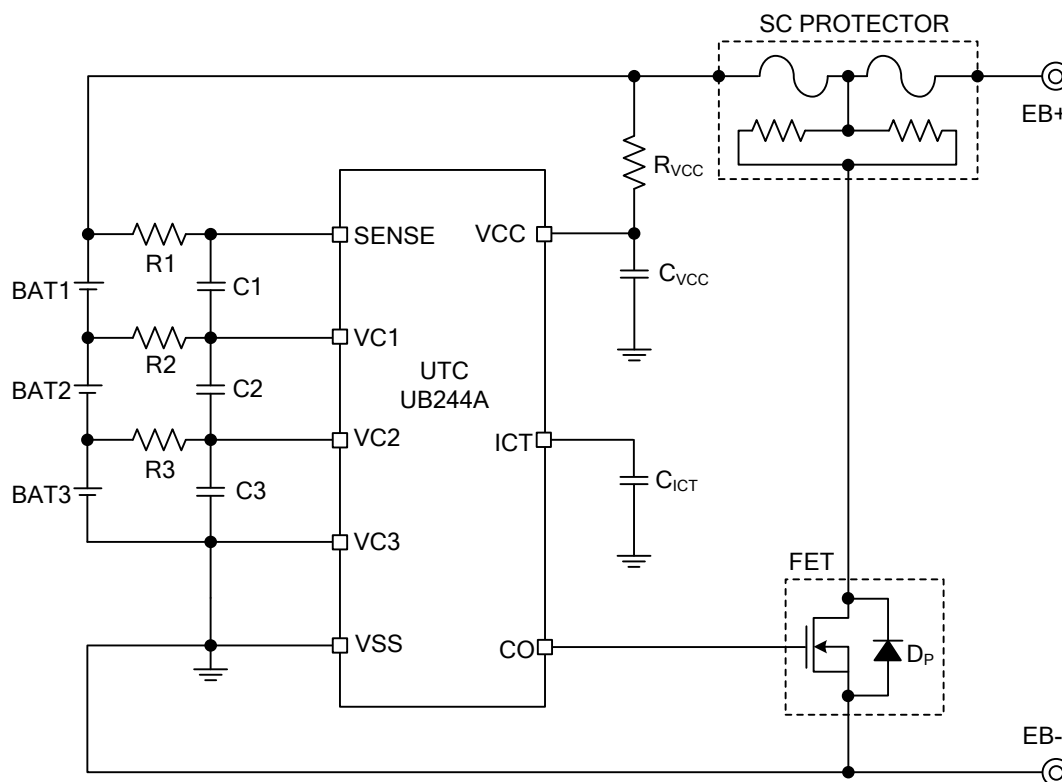

Constants for External Components 3

SYMBOL	MIN	TYP	MAX	UNIT
R1 to R3	0	1 k	10 k	Ω
C1 to C3	0	0.1	1	μF
R_{VCC}	0	100	1 k	Ω
C_{VCC}	0	0.1	1	μF
C_{ICT}	0	0.1	1	μF

- Notes:
1. The above constants may be changed without notice.
 2. It has not been confirmed whether the operation is normal or not in circuits other than the above example of connection. In addition, the example of connection shown above and the constant do not guarantee proper operation. Perform through evaluation using the actual application to set the constant.

■ TYPICAL APPLICATION CIRCUIT(Cont.)

(4) Connection Example 4 (for 2-cells)

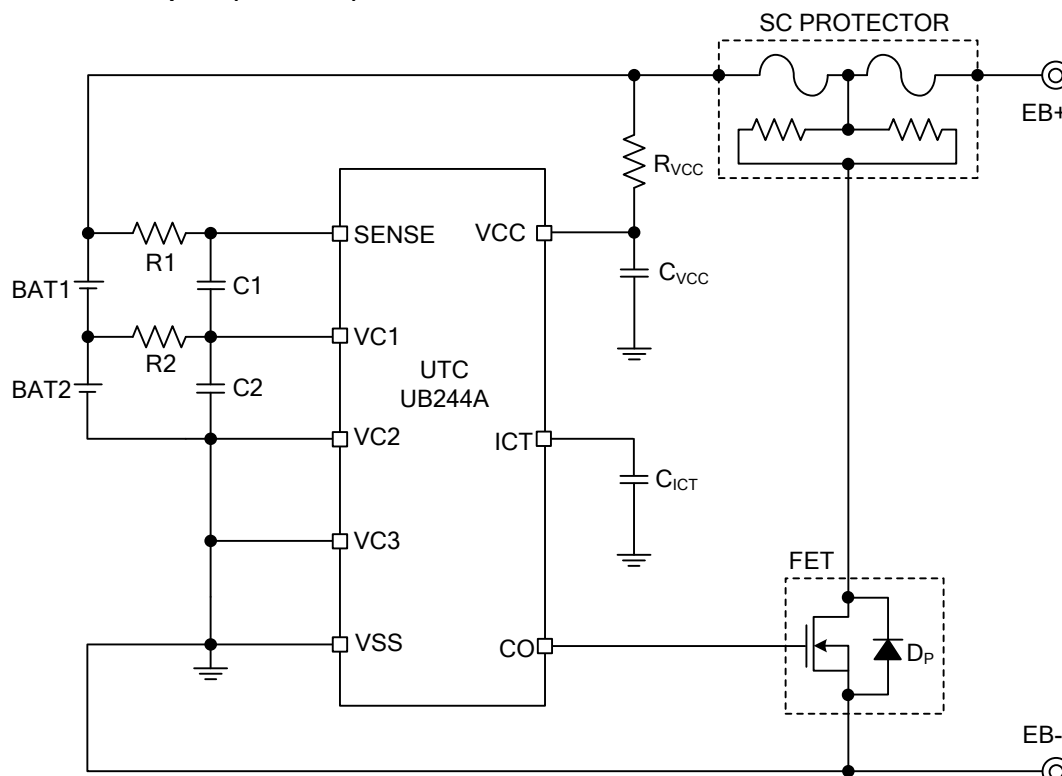

Constants for External Components 4

SYMBOL	MIN	TYP	MAX	UNIT
R1 to R2	0	1 k	10 k	Ω
C1 to C2	0	0.1	1	μF
R_{VCC}	0	100	1 k	Ω
C_{VCC}	0	0.1	1	μF
C_{ICT}	0	0.1	1	μF

- Notes:
1. The above constants may be changed without notice.
 2. It has not been confirmed whether the operation is normal or not in circuits other than the above example of connection. In addition, the example of connection shown above and the constant do not guarantee proper operation. Perform through evaluation using the actual application to set the constant.

■ TYPICAL APPLICATION CIRCUIT(Cont.)

(5) Connection Example 5 (for 1-cell)

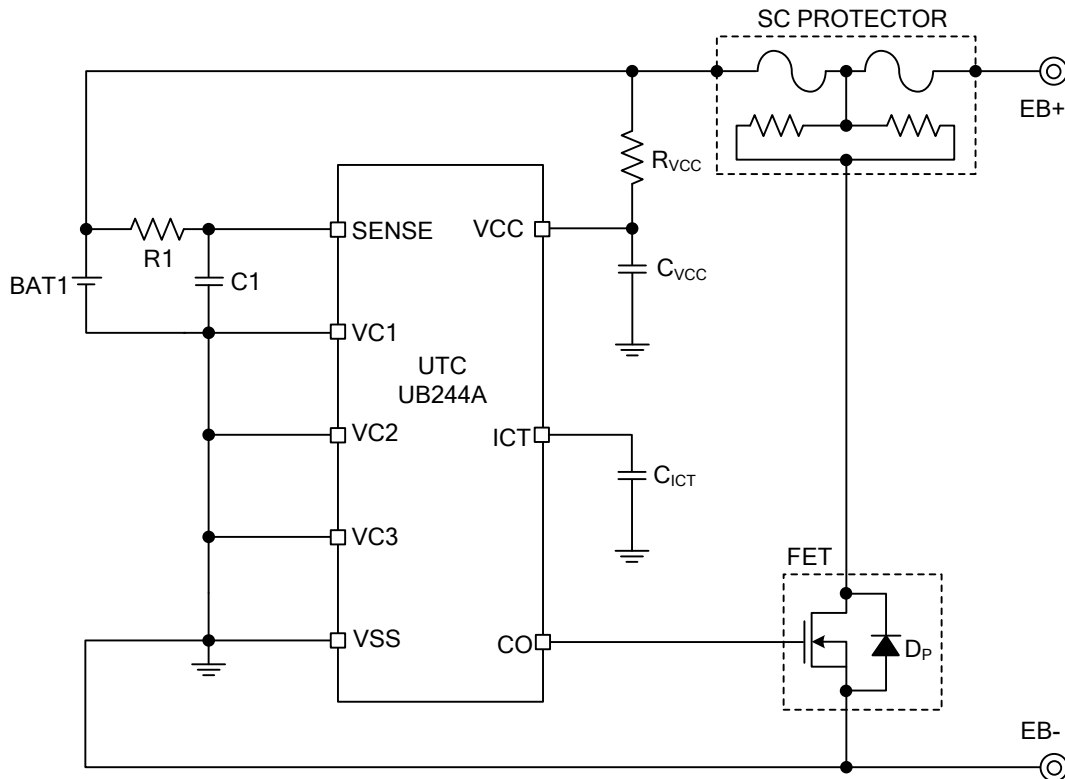

Constants for External Components 5

SYMBOL	MIN	TYP	MAX	UNIT
R1	0	1 k	10 k	Ω
C1	0	0.1	1	μF
R _{vcc}	0	100	1 k	Ω
C _{vcc}	0	0.1	1	μF
C _{ict}	0	0.1	1	μF

- Notes:
1. The above constants may be changed without notice.
 2. It has not been confirmed whether the operation is normal or not in circuits other than the above example of connection. In addition, the example of connection shown above and the constant do not guarantee proper operation. Perform through evaluation using the actual application to set the constant.

■ PRECAUTIONS

1. DO NOT connect any of overcharged batteries. Even if only one overcharged battery is connected to this IC, the IC detects overcharge, then charge current flows to the delay capacitor through the parasitic diode between pins where the battery is not connected yet. This may lead to a malfunction. Please perform sufficient evaluation in the case of use. Depending on an application circuit, even when the fault charge battery is not contained, the connection turn of a battery may be restricted in order to prevent the output of CO detection pulse at the time of battery connection.
2. Any position from V1 to V4 can be used when applying this IC for a one to three-cell battery. However, be sure to short circuit between pins not in use (SENSE-VC1, VC1-VC2, VC2-VC3, or VC3-VSS).
3. The application conditions for the input voltage, output voltage, and load current should not exceed the package power dissipation.
4. Do not apply an electrostatic discharge to this IC that exceeds the performance ratings of the built-in electrostatic protection circuit.

UTC assumes no responsibility for equipment failures that result from using products at values that exceed, even momentarily, rated values (such as maximum ratings, operating condition ranges, or other parameters) listed in products specifications of any and all UTC products described or contained herein. UTC products are not designed for use in life support appliances, devices or systems where malfunction of these products can be reasonably expected to result in personal injury. Reproduction in whole or in part is prohibited without the prior written consent of the copyright owner. The information presented in this document does not form part of any quotation or contract, is believed to be accurate and reliable and may be changed without notice.