

2A, 23V, 380KHz Step-Down Converter



General Description

The FP6185 is a buck regulator with a built-in internal power MOSFET. It achieves 2A continuous output current over a wide input supply range with excellent load and line regulation. Current mode operation provides fast transient response and eases loop stabilization. The device includes cycle-by-cycle current limiting and thermal shutdown protection. Adjustable soft-start reduces the stress on the input source during power-on. The regulator only consumes 23 μ A supply current in shutdown mode. The FP6185 requires a minimum number of readily available external components to complete a 2A buck regulator solution.

Features

- 2A Output Current
- Adjustable Soft-Start
- 0.18 Ω Internal High Side Power MOSFET Switch
- Stable with Low ESR Output Ceramic Capacitors
- Up to 95% Efficiency
- 23 μ A Shutdown Mode Current
- Fixed 380KHz Frequency
- Thermal Shutdown
- Cycle-by-Cycle Over Current Protection
- Wide 4.75 to 23V Operating Input Range
- Output Adjustable From 0.92 to 16V
- Available Package: SOP-8L
- Under Voltage Lockout

Applications

- Distributed Power Systems
- Battery Charger
- Pre-Regulator for Linear Regulators
- DSL Modems

Typical Application Circuit

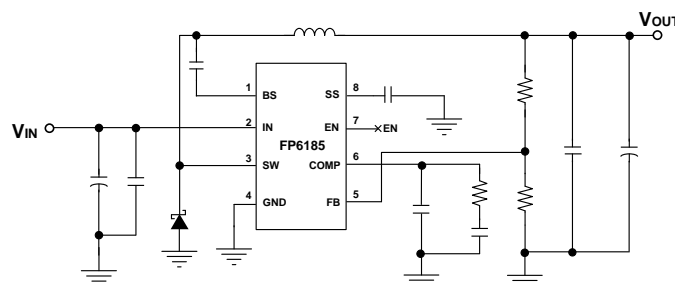

This datasheet contains new product information. Feeling Technology reserves the rights to modify the product specification without notice. No liability is assumed as a result of the use of this product. No rights under any patent accompany the sales of the product.

Function Block Diagram

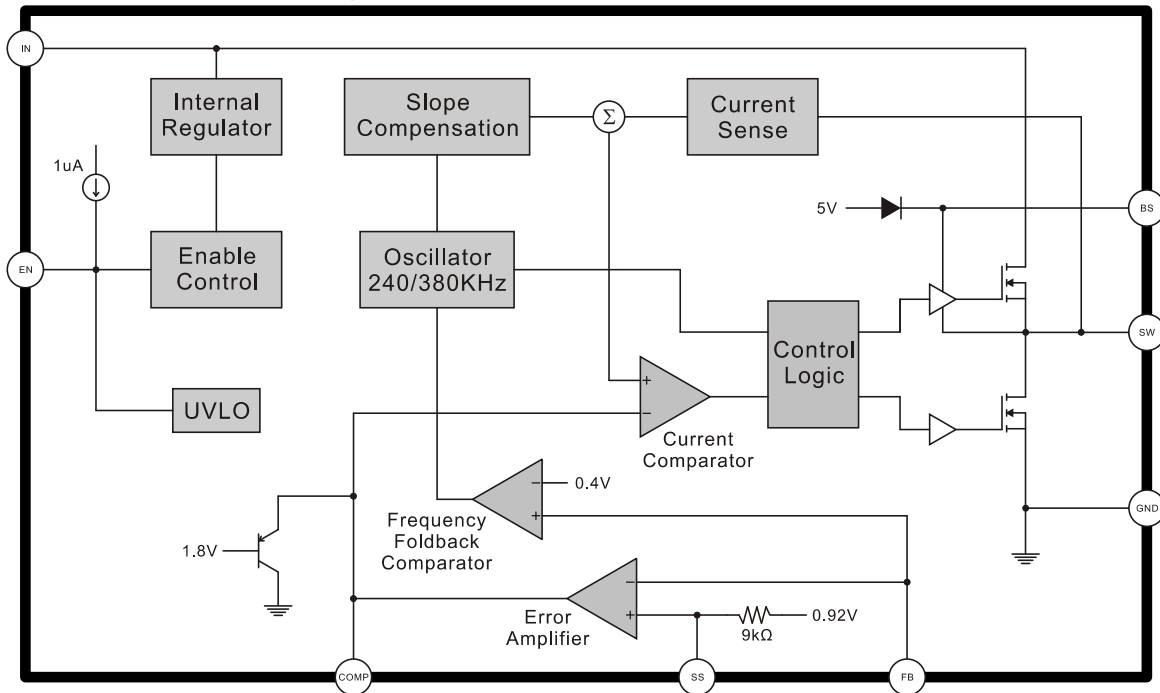

Pin Descriptions

SOP-8L

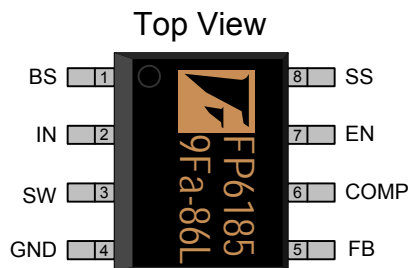

Name	No.	I / O	Description
BS	1	O	Bootstrap
IN	2	P	Supply Voltage
SW	3	O	Switch
GND	4	P	Ground
FB	5	I	Feedback
COMP	6	O	Compensation
EN	7	I	Enable / UVLO
SS	8	O	Programmable Soft Start

This datasheet contains new product information. Feeling Technology reserves the rights to modify the product specification without notice. No liability is assumed as a result of the use of this product. No rights under any patent accompany the sales of the product.

Marking Information

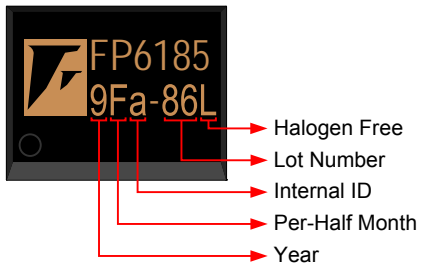

Halogen Free: Halogen free product indicator

Lot Number: Wafer lot number's last two digits

For Example: 132386TB → 86

Internal ID: Internal Identification Code

Per-Half Month: Production period indicated in half month time unit

For Example: January → A (Front Half Month), B (Last Half Month)

February → C (Front Half Month), D (Last Half Month)

Year: Production year's last digit

Ordering Information

Part Number	Operating Temperature	Package	MOQ	Description
FP6185DR-G1	-40°C ~ +85°C	SOP-8L	2500 EA	Tape & Reel

Absolute Maximum Ratings

Parameter	Symbol	Conditions	Min.	Typ.	Max.	Unit
Supply Voltage	V_{IN}		-0.3		24	V
Switch Voltage	V_{SW}		-1		$V_{IN}+0.3$	V
Boost Voltage	V_{BS}		$V_{SW}-0.3$		$V_{SW}+6$	V
All Other Pins			-0.3V		6	V
Thermal Resistance	θ_{JA}	SOP-8L			175	°C / W
Thermal Resistance	θ_{JC}	SOP-8L			55	°C / W
Junction Temperature	T_J				110	°C
Storage Temperature			-65		150	°C
Lead Temperature (soldering, 10 sec)		SOP-8L			260	°C
Allowable Power Dissipation ($T_A \leq +25^\circ\text{C}$)		SOP-8L			570	mW

IR Re-flow Soldering Curve

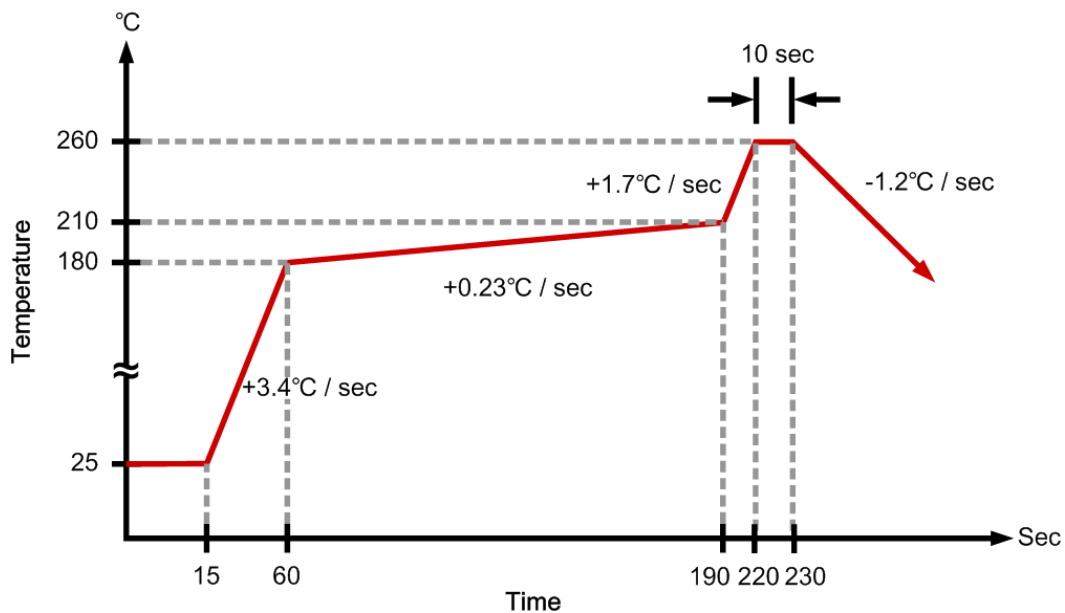

This datasheet contains new product information. Feeling Technology reserves the rights to modify the product specification without notice. No liability is assumed as a result of the use of this product. No rights under any patent accompany the sales of the product.

Recommended Operating Conditions

Parameter	Symbol	Conditions	Min.	Typ.	Max.	Unit
Supply Voltage	V_{IN}		4.75		23	V
Operating Temperature			-40		+85	°C

DC Electrical Characteristics ($T_A = 25^\circ\text{C}$, $V_{IN} = 12\text{V}$, unless otherwise noted)

Parameter	Symbol	Conditions	Min.	Typ.	Max.	Unit
Standby Current	I_{ST}	$V_{EN} \geq 3\text{V}, V_{FB} > 1\text{V}$	0.3	0.5	0.7	mA
Operating Current	I_{CC}	$V_{EN} \geq 3\text{V}$	3.2	4.2	6.1	mA
Shutdown Supply Current	I_{SH}	$V_{EN} = 0$	15	23	36	μA
Feedback Voltage	V_{FB}	$V_{IN} = 12\text{V}, V_{COMP} < 2\text{V}$	0.892	0.92	0.948	V
Current Sense Tran-conductance Output Current to Comp Pin Voltage	T_{CS}			2.1		A / V
Error Amplifier Voltage Gain	G_{EA}			400		V / V
Error Amplifier Tran-conductance	T_{EA}	$\Delta I_{COMP} = \pm 10\mu\text{A}$		830		$\mu\text{A} / \text{V}$
High Side Switch On Resistance	R_{ON-HS}			0.18		Ω
Low Side Switch On Resistance	R_{ON-LS}			10		Ω
High Side Switch Leakage Current	I_{IL}	$V_{EN} = 0, V_{SW} = 0\text{V}$		0.1	10	μA
Current Limit	I_{CL}			3.4		A
Oscillation Frequency	f_{OSC}			380		KHz
Short Circuit Oscillation Frequency	f_{SC}	$V_{FB} = 0\text{V}$		240		KHz
Maximum Duty Cycle	D_{MAX}	$V_{FB} = 0.8\text{V}$		90		%
Minimum On Time	T_{ON}			100		ns
Under Voltage Lockout Threshold	V_{UVLO}		2.37	2.5	2.62	V
Under Voltage Lockout Threshold Hysteresis	V_{HYS}			210		mV
EN Threshold Voltage	V_{EN}	$I_{CC} > 100\mu\text{A}$	0.7	1	1.3	V
Enable Pin Pull Up Current	I_{EN}	$V_{EN} = 0\text{V}$		1		μA
Soft-Start Pin Equivalent Output Resistance	R_{SS}			9		k Ω
Thermal Shutdown	T_{TS}			+150		°C
Thermal Shutdown Reset Hysteresis	T_{HYS}			+40		°C

This datasheet contains new product information. Feeling Technology reserves the rights to modify the product specification without notice. No liability is assumed as a result of the use of this product. No rights under any patent accompany the sales of the product.

Typical Operating Characteristics

($T_A = 25^\circ\text{C}$, $V_{IN} = 12\text{V}$, unless otherwise noted)

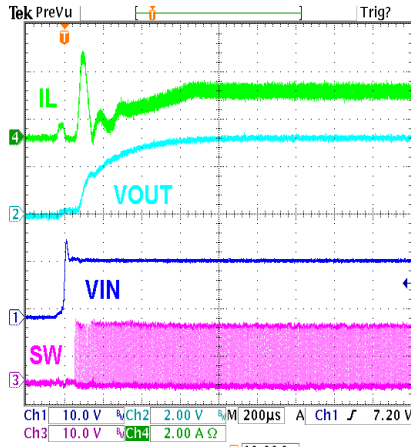

Figure 1: Power on

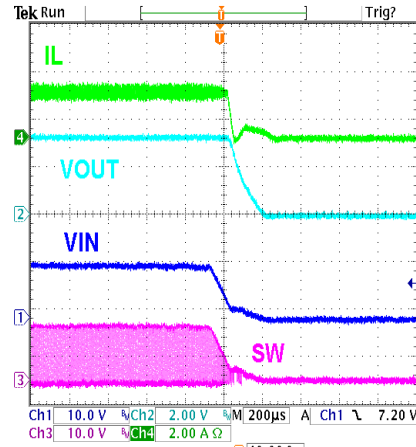

Figure 2: Power off

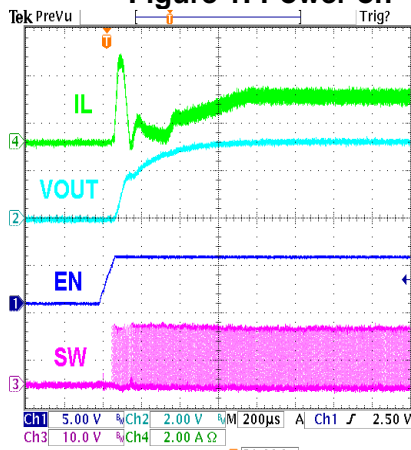

Figure 3: EN Pin Enable

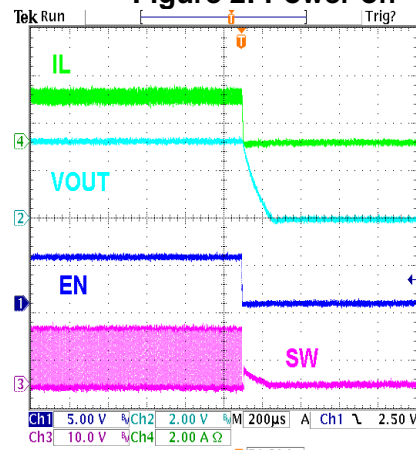

Figure 4: EN Pin Disable

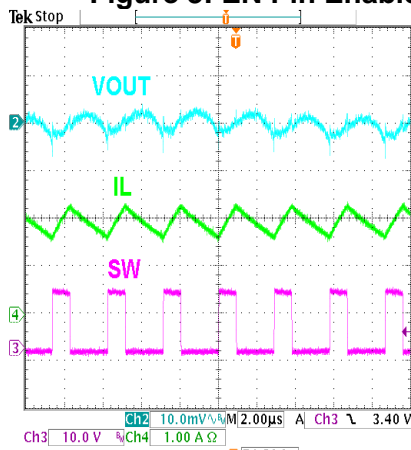

Figure 5: Load 2A

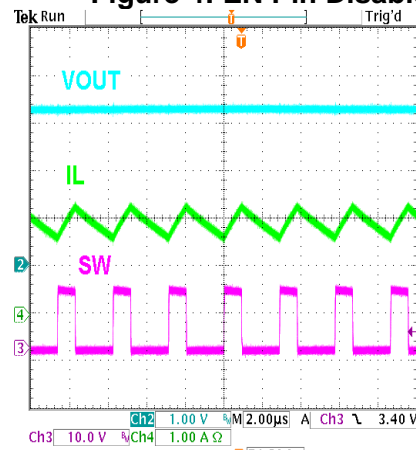

Figure 6: Load 2A Ripple

This datasheet contains new product information. Feeling Technology reserves the rights to modify the product specification without notice. No liability is assumed as a result of the use of this product. No rights under any patent accompany the sales of the product.

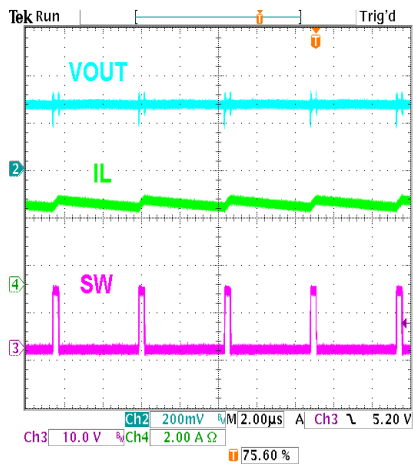

Figure 7: SCP

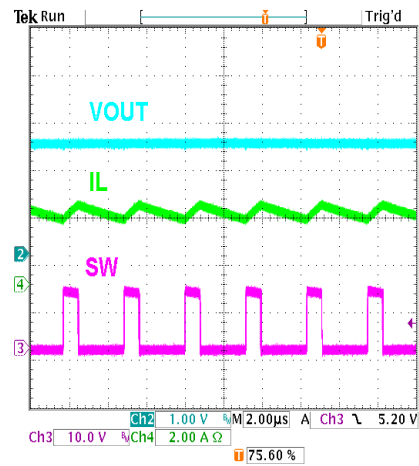

Figure 8: OCP

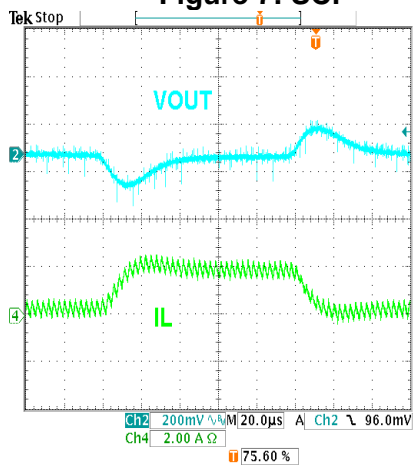

Figure 9: Load Step

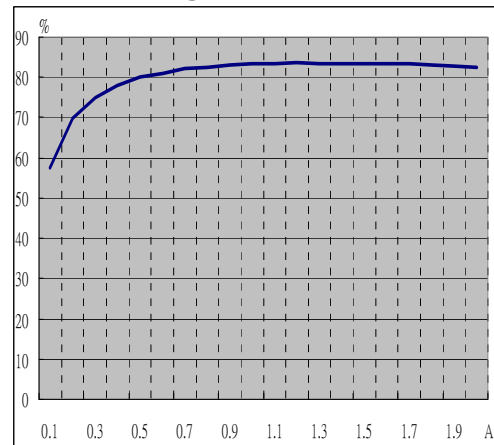

Figure 10: Efficiency
 $V_{IN}=12V$ $V_{OUT}=3.3V$

Function Description

The FP6185 is a current-mode buck regulator. It regulates input voltages from 4.75V to 23V down to an output voltage as low as 0.92V, and is able to supply up to 2A of load current. The FP6185 uses current-mode control to regulate the output voltage. The output voltage is measured at FB through a resistive voltage divider and amplified through the internal error amplifier. The output current of the Trans-conductance error amplifier is presented at COMP pin where a frequency compensation network stabilizes the regulation system. The voltage at COMP is compared to the switch current measured internally to control the output voltage.

The converter uses an internal n-channel MOSFET switch to step down the input voltage to the regulated output voltage. Since the MOSFET requires a gate voltage greater than the input voltage, a boost capacitor connected between SW and BS drives the gate. The capacitor is internally charged while the switch is off. An internal 10Ω switch from SW to GND is used to insure the SW is pulled to GND when the switch is off to fully charge the BS capacitor.

Output Voltage (V_{OUT})

The output voltage is set using a resistive voltage divider from the output voltage to FB. The voltage divider divides the output voltage down by the ratio:

$$V_{FB} = V_{OUT} \times \frac{R_4}{R_2 + R_4}$$

Thus the output voltage is:

$$V_{OUT} = V_{FB} \times \frac{R_2 + R_4}{R_4}$$

A typical value for R_4 can be as high as 100kΩ, but a typical value is 10kΩ.

Shutdown Mode

Drive ENABLE pin to ground to shut down the FP6185. Shutdown forces the internal power MOSFET off, turns off all internal circuitry, and reduces the V_{IN} supply current to 23μA (typ.). The ENABLE pin rising threshold is 1V (typ.). Before any operation begins, the voltage at ENABLE pin must exceed 1V (typ.). The ENABLE pin input has 100mV hysteresis.

Boost High-Side Gate Drive (BST)

Since the MOSFET requires a gate voltage greater than the input voltage, connect a flying bootstrap capacitor between SW and BS to provide the gate-drive voltage to the high-side n-channel MOSFET switch. The capacitor is alternately charged from the internally regulator during SW pin pulled to ground period.

On startup, an internal low-side switch connects SW to ground and charges the BST capacitor to internally regulator voltage. Once the BST capacitor is charged, the internal low-side switch is turned off and the BST capacitor voltage provides the necessary enhancement voltage to turn on the high-side switch.

Thermal Shutdown Protection

The FP6185 features integrated thermal shutdown protection. Thermal shutdown protection limits allowable power dissipation (PD) in the device, and protects the device in the event of a fault condition. When the IC junction temperature exceeds +150°C, an internal thermal sensor signals the shutdown logic, turning off the internal power MOSFET and allowing the IC to cool down. The thermal sensor turns the internal power MOSFET back on after the IC junction temperature cools down to + 110°C, resulting in a pulsed output under continuous thermal overload conditions.

Application Information

Input Capacitor Selection

The input current to the step-down converter is discontinuous, therefore a capacitor is required to supply the AC current to the step-down converter while maintaining the DC input voltage. Use low ESR capacitors for the best performance. Ceramic capacitors are preferred, but tantalum or low-ESR electrolytic capacitors may also suffice.

When using electrolytic or tantalum capacitors, a small high quality 0.1 μ F ceramic capacitor should be placed closely to the IC as possible.

When using ceramic capacitors, make sure that they have enough capacitance to provide sufficient charge to prevent excessive voltage ripple at input. The required C_{IN} to suppress input voltage ripple can be estimated by

$$C_{IN} = \frac{I_o}{f \times \Delta V_{IN}} \times D(1-D)$$

Inductor Selection

The inductor is required to supply constant current to the output load while being driven by the switched input voltage. A larger value inductor will result in less ripple current that will result in lower output ripple voltage. However, the larger value inductor will have a larger physical size, higher series resistance, and sometimes lower saturation current. A good rule for determining the inductance to use is to allow the peak-to-peak ripple current in the inductor to be approximately 30% of the maximum switch current limit. Also, make sure that the peak inductor current is below the maximum switch current limit. The inductance value can be calculated by

$$L = \frac{V_o + V_D}{I_o \gamma f} (1-D)$$

Where γ is the ripple current ratio, $\gamma = \Delta I_L / I_{LOAD}$

$$\text{RMS current in inductor } I_{L_{rms}} = I_o \sqrt{1 + \frac{\gamma^2}{12}}$$

Output Capacitor Selection

The output capacitor is required to maintain the DC output voltage. Ceramic, tantalum, or low ESR electrolytic capacitors are recommended. Low ESR capacitors are preferred to keep the output voltage ripple low. The output voltage ripple can be estimated by:

$$\Delta V_{OUT} = \frac{V_{OUT} \times (V_{IN} - V_{OUT})}{f \times L \times V_{IN}} * \left(\text{ESR} + \frac{1}{8 \times f \times C_{OUT}} \right)$$

In the case of ceramic capacitors, the impedance at the switching frequency is dominated by the

This datasheet contains new product information. Feeling Technology reserves the rights to modify the product specification without notice. No liability is assumed as a result of the use of this product. No rights under any patent accompany the sales of the product.

capacitance. The output voltage ripple is mainly decided by the capacitance value. Choose the capacitor value with following equation.

$$C_{OUT} = \frac{V_{OUT}}{8 \times f^2 \times L \times \Delta V_{OUT}} \times \left(1 - \frac{V_{OUT}}{V_{IN}}\right)$$

In the case of tantalum or electrolytic capacitors, the ESR dominates the impedance at the switching frequency. Choose the capacitor with suitable ESR calculated following.

$$ESR = \frac{\Delta V_{OUT} \times f \times L \times V_{IN}}{V_{OUT} \times (V_{IN} - V_{OUT})}$$

PC Board Layout Checklist

The power traces, consisting of the GND trace, the SW trace and the V_{IN} trace should be kept short, direct and wide.

Place C_{IN} near IN Pin as closely as possible to maintain input voltage steady and filter out the pulsing input current.

The resistive divider R_2 and R_4 must be connected to FB pin directly as close as possible.

FB is a sensitive node. Please keep it away from switching node, SW. A good approach is to route the feedback trace on another layer and to have a ground plane between the top layer and the layer on which the feedback trace is routed. This reduces switching EMI radiation to disturb the DC-DC converter's own voltage feedback trace.

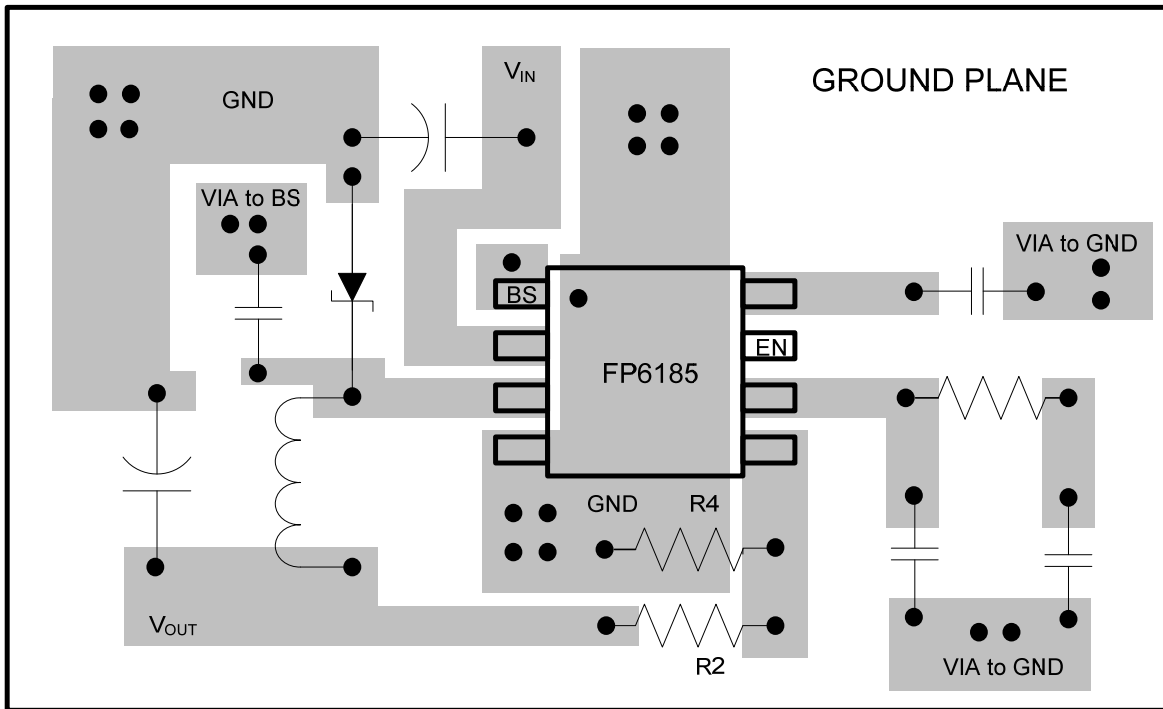

Suggested Layout

Typical Application

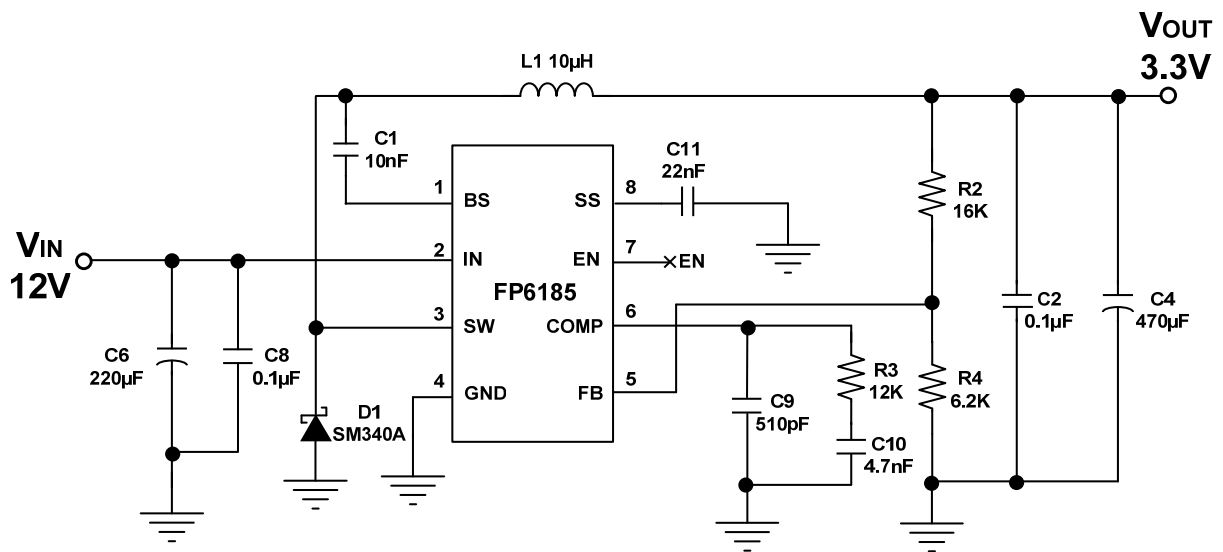

This datasheet contains new product information. Feeling Technology reserves the rights to modify the product specification without notice. No liability is assumed as a result of the use of this product. No rights under any patent accompany the sales of the product.

Package Outline

SOP-8L

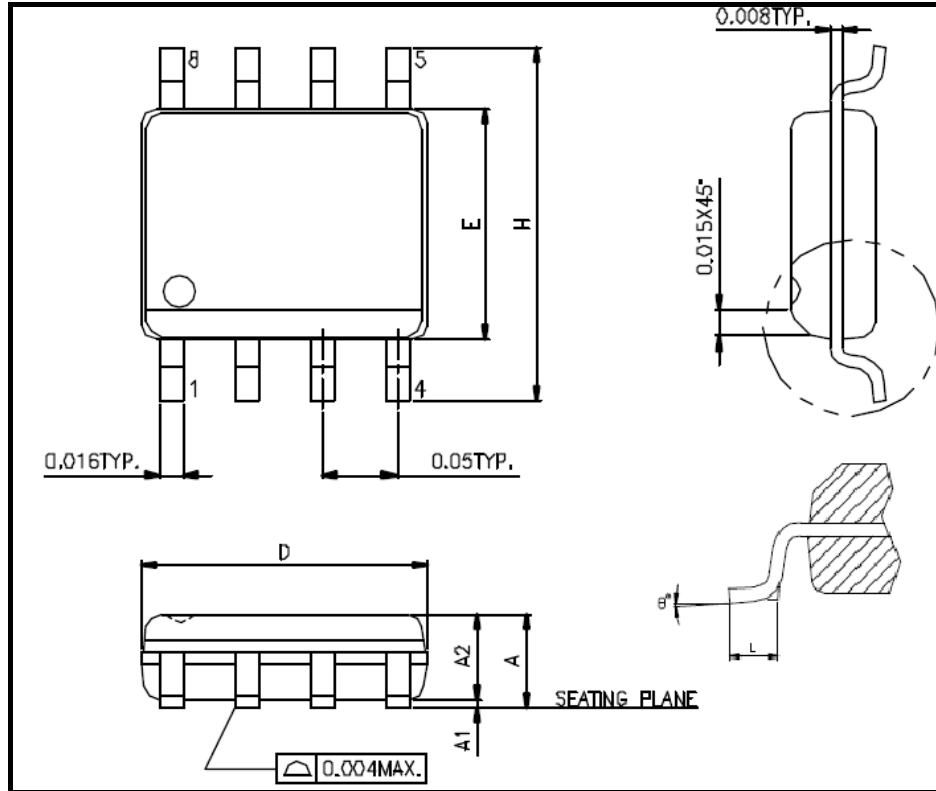

UNIT:mm

Symbols	Min. (mm)	Max. (mm)
A	1.346	1.752
A1	0.101	0.254
A2		1.498
D	4.800	4.978
E	3.810	3.987
H	5.791	6.197
L	0.406	1.270
θ°	0°	8°

Note:

1. Package dimensions are in compliance with JEDEC Outline: MS-012 AA.
2. Dimension "D" does not include molding flash, protrusions gate burrs.
3. Dimension "E" does not include inter-lead flash, or protrusions.

This datasheet contains new product information. Feeling Technology reserves the rights to modify the product specification without notice. No liability is assumed as a result of the use of this product. No rights under any patent accompany the sales of the product.