

# 16-bit Proprietary Microcontroller

CMOS

## F<sup>2</sup>MC-16LX MB90340 Series

MB90F342/C(S), MB90F343/C(S), MB90F345/C(S), MB90F346/C(S), MB90F347/C(S),  
MB90F349/C(S), MB90341/C(S), MB90342/C(S), MB90346/C(S), MB90347/C(S),  
MB90348/C(S), MB90349/C(S), MB90V340(S)

### ■ DESCRIPTION

The MB90340-series with up to 2 FULL-CAN\* interfaces and FLASH ROM is especially designed for automotive and industrial applications. Its main features are the on-board CAN Interfaces, which conform to V2.0 Part A and Part B, while supporting a very flexible message buffer scheme and so offering more functions than a normal full CAN approach. With the new 0.35  $\mu\text{m}$  CMOS technology, Fujitsu now offers on-chip FLASH-ROM program memory up to 512 Kbytes. An internal voltage booster removes the necessity for a second programming voltage.

An on board voltage regulator provides 3 V to the internal MCU core. This creates a major advantage in terms of EMI and power consumption.

The internal PLL clock frequency multiplier provides an internal 42 ns instruction cycle time from an external 4 MHz clock.

The unit features an 8 channel Output Compare Unit and 8 channel Input Capture Unit with 2 separate 16-bit free running timers. 4 UARTs constitute additional functionality for communication purposes.

\* : Controller Area Network (CAN) - License of Robert Bosch GmbH

Note : F<sup>2</sup>MC stands for FUJITSU Flexible Microcontroller, a registered trademark of FUJITSU LIMITED.

### ■ PACKAGES

100-pin Plastic QFP

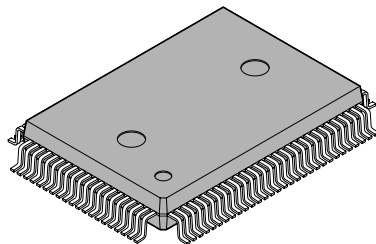

(FPT-100P-M06)

100-pin Plastic LQFP

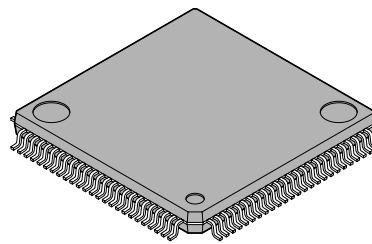

(FPT-100P-M05)

# MB90340 Series

## ■ FEATURES

### • Clock

- Built-in PLL clock frequency multiplication circuit
- Selection of machine clocks (PLL clocks) is allowed among frequency division by two on oscillation clock, and multiplication of 1 to 6 times of oscillation clock (for 4 MHz oscillation clock, 4 MHz to 24 MHz).
- Operation by sub-clock (up to 50 kHz : 100 kHz oscillation clock divided two) is allowed. (devices without S-suffix only)
- Minimum execution time of instruction : 42 ns (when operating with 4-MHz oscillation clock, and 6-time multiplied PLL clock).

### • 16 Mbyte CPU memory space

- 24-bit internal addressing

### • Instruction system best suited to controller

- Wide choice of data types (bit, byte, word, and long word)
- Wide choice of addressing modes(23 types)
- Enhanced multiply-divide instructions and RETI instructions
- Enhanced high-precision computing with 32-bit accumulator

### • Instruction system compatible with high-level language (C language) and multitask

- Employing system stack pointer
- Enhanced various pointer indirect instructions
- Barrel shift instructions

### • Increased processing speed

- 4-byte instruction queue

### • Powerful interrupt function

- Powerful 8-level, 34-condition interrupt feature
- Up to 16 external interrupts are supported

### • Automatic data transfer function independent of CPU

- Expanded intelligent I/O service function (EI<sup>2</sup>OS) : up to 16 channels
- DMA : up to 16 channels

### • Low power consumption (standby) mode

- Sleep mode (a mode that halts CPU operating clock)
- Time-base timer mode (a mode that operates oscillation clock, sub clock, time-base timer and clock timer only)
- Watch mode (a mode that operates sub clock and clock timer only)
- Stop mode (a mode that stops oscillation clock and sub clock)
- CPU blocking operation mode

### • Process

- CMOS technology

### • I/O port

- General-purpose input/output port (CMOS output)
  - 80 ports (devices without S-suffix)
  - 82 ports (devices with S-suffix)

### • Timer

- Time-base timer, clock timer, watchdog timer : 1 channel
- 8/16-bit PPG timer : 8-bit X 16 channels, or 16-bit X 8 channels
- 16-bit reload timer : 4 channels
- 16-bit input/output timer
  - 16-bit free run timer : 2 channel (FRT0 : ICU 0/1/2/3, OCU 0/1/2/3, FRT1 : ICU 4/5/6/7, OCU 4/5/6/7)

- 16-bit input capture: (ICU) : 8 channels
- 16-bit output compare : (OCU) : 8 channels

- **Full-CAN interface : up to 2 channels**

- Compliant with Ver2.0A and Ver2.0B CAN specifications
- Flexible message buffering (mailbox and FIFO buffering can be mixed)
- CAN wake-up function

- **UART (LIN/SCI) : up to 4 channels**

- Equipped with full-duplex double buffer
- Clock-asynchronous or clock-synchronous serial transmission is available

- **I<sup>2</sup>C interface\* : up to 2 channels (devices with C-suffix only)**

- Up to 400 kbit/s transfer rate

- **DTP/External interrupt : up to 16 channels, CAN wakeup : up to 2 channels**

- Module for activation of expanded intelligent I/O service (EI<sup>2</sup>OS), DMA, and generation of external interrupt.

- **Delay interrupt generator module**

- Generates interrupt request for task switching.

- **8/10-bit A/D converter : 16/24 channels**

- Resolution is selectable between 8-bit and 10-bit.
- Activation by external trigger input is allowed.
- Conversion time : 3  $\mu$ s (at 24-MHz machine clock, including sampling time)

- **Program patch function**

- Address matching detection for 6 address pointers.

- **Internal voltage regulator**

- Supports 3 V MCU core, offering low EMI and low power consumption figures

- **Programmable input levels**

- Automotive/CMOS-Schmitt (initial level is Automotive in Single chip mode)
- TTL level (initial level for External bus mode)

- **ROM security function**

- Protects the content of ROM (MASK ROM device only)

- **External bus interface**

- **Clock monitor function**

\* : I<sup>2</sup>C license :

This product includes licensing of Phillips I<sup>2</sup>C patents if used by the customer in an I<sup>2</sup>C system subject to the I<sup>2</sup>C standard specifications established by Phillips.

# MB90340 Series

## ■ PRODUCT LINEUP

Part Number	MB90F342/C(S), MB90F343/C(S)*1, MB90F345/C(S), MB90F346/C(S), MB90F347/C(S), MB90F349/C(S), MB90341/C(S)*1, MB90342/C(S)*1, MB90346/C(S), MB90347/C(S), MB90348/C(S)*1, MB90349/C(S)*1	MB90V340(S)
Parameter		
CPU	F <sup>2</sup> MC-16LX CPU	
System clock	On-chip PLL clock multiplier (×1, ×2, ×3, ×4, ×6, 1/2 when PLL stops) Minimum instruction execution time : 42 ns (4 MHz osc. PLL × 6)	
ROM	Boot-block, Flash memory 512 Kbytes : MB90F345/C (S) 384 Kbytes : MB90F343/C (S) 256 Kbytes : MB90F342/C (S) , MB90F349/C (S) , MB90342/C (S) , MB90349/C (S) 128 Kbytes : MB90F347/C (S) , MB90341/C (S) , MB90348/C (S) , MB90347/C (S) 64 Kbytes : MB90F346/C (S) , MB90346/C (S)	External
RAM	20 Kbytes : MB90F343/C (S) , MB90F345/C (S) 16 Kbytes : MB90F342/C (S) , MB90F349/C (S) , MB90341/C (S) , MB90342/C (S) , MB90348/C (S) , MB90349/C (S) 6 Kbytes : MB90F347/C (S) , MB90347/C (S) 2 Kbytes : MB90F346/C (S) , MB90346/C (S)	30 Kbytes
Emulator-specific power supply <sup>2</sup>	—	Yes
Technology	0.35 μm CMOS with on-chip voltage regulator for internal power supply + Flash memory with On-chip charge pump for programming voltage	0.35 μm CMOS with on-chip voltage regulator for internal power supply
Operating voltage range	3.5 V - 5.5 V : at normal operating (not using A/D converter) 4.0 V - 5.5 V : at using A/D converter/Flash programming 4.5 V - 5.5 V : at using external bus	5 V ± 10%
Temperature range	-40 °C to +105 °C	—
Package	QFP-100, LQFP-100	PGA-299
UART	4 channels	5 channels
	Wide range of baud rate settings using a dedicated reload timer Special synchronous options for adapting to different synchronous serial protocols LIN functionality working either as master or slave LIN device	
I <sup>2</sup> C (400 kbit/s)	devices with 'C'-suffix : 2ch devices without 'C'-suffix : —	2 channel
A/D Converter	devices with 'C'-suffix : 24ch devices without 'C'-suffix : 16ch	24 input channels
	10-bit or 8-bit resolution Conversion time : Min 3 μs include sample time (per one channel)	
16-bit Reload Timer (4 channels)	Operation clock frequency : fsys/2 <sup>1</sup> , fsys/2 <sup>3</sup> , fsys/2 <sup>5</sup> (fsys = Machine clock frequency) Supports External Event Count function	
16-bit I/O Timer (2 channels)	Signals an interrupt when overflowing Supports Timer Clear when a match with Output Compare (Channel 0, 4) Operation clock freq. : fsys, fsys/2 <sup>1</sup> , fsys/2 <sup>2</sup> , fsys/2 <sup>3</sup> , fsys/2 <sup>4</sup> , fsys/2 <sup>5</sup> , fsys/2 <sup>6</sup> , fsys/2 <sup>7</sup> (fsys = Machine clock freq.) I/O Timer 0 (clock input FRCK0) corresponds to ICU 0/1/2/3, OCU 0/1/2/3 I/O Timer 1 (clock input FRCK1) corresponds to ICU 4/5/6/7, OCU 4/5/6/7	

(Continued)

# MB90340 Series

Part Number	MB90F342/C(S), MB90F343/C(S)*1, MB90F345/C(S), MB90F346/C(S), MB90F347/C(S), MB90F349/C(S), MB90341/C(S)*1, MB90342/C(S)*1, MB90346/C(S), MB90347/C(S), MB90348/C(S)*1, MB90349/C(S)*1	MB90V340(S)
Parameter		
16-bit Output Compare (8 channels)	Signals an interrupt when 16-bit I/O Timer match output compare registers. A pair of compare registers can be used to generate an output signal.	
16-bit Input Capture (8 channels)	Rising edge, falling edge or rising & falling edge sensitive Signals an interrupt upon external event	
8/16-bit Programmable Pulse Generator (8 channels)	Supports 8-bit and 16-bit operation modes Sixteen 8-bit reload counters Sixteen 8-bit reload registers for L pulse width Sixteen 8-bit reload registers for H pulse width A pair of 8-bit reload counters can be configured as one 16-bit reload counter or as 8-bit prescaler plus 8-bit reload counter Operation clock freq. : fsys, fsys/2 <sup>1</sup> , fsys/2 <sup>2</sup> , fsys/2 <sup>3</sup> , fsys/2 <sup>4</sup> or 128 μs@fosc = 4 MHz (fsys = Machine clock frequency, fosc = Oscillation clock frequency)	
CAN Interface	2 channels : MB90F342/C (S) , MB90F343/C (S) , MB90F345/C (S) , MB90341/C (S) , MB90342/C (S) 1channel : MB90F346/C (S) , MB90F347/C (S) , MB90F349/C (S) , MB90346/C (S) , MB90347/C (S) , MB90348/C (S) , MB90349/C (S)	3 channels
	Conforms to CAN Specification Version 2.0 Part A and B Automatic re-transmission in case of error Automatic transmission responding to Remote Frame Prioritized 16 message buffers for data and ID's Supports multiple messages Flexible configuration of acceptance filtering : Full bit compare/Full bit mask/Two partial bit masks Supports up to 1 Mbps	
External Interrupt (16 channels)	Can be used rising edge, falling edge, starting up by H/L level input, external interrupt, expanded intelligent I/O services (EI <sup>2</sup> OS) and DMA	
D/A converter	—	2 channels
Up to 100 kHz Subclock for low power operation	devices with 'S'-suffix : with subclock devices without 'S'-suffix : without subclock	
I/O Ports	Virtually all external pins can be used as general purpose I/O port All push-pull outputs Bit-wise settable as input/output or peripheral signal Settable in pin-wise of 8 as CMOS schmitt trigger/ automotive inputs (default) TTL input level settable for external bus (32-pin only for external bus)	

(Continued)

# MB90340 Series

(Continued)

Part Number	MB90F342/C(S), MB90F343/C(S)*1, MB90F345/C(S), MB90F346/C(S), MB90F347/C(S), MB90F349/C(S), MB90341/C(S)*1, MB90342/C(S)*1, MB90346/C(S), MB90347/C(S), MB90348/C(S)*1, MB90349/C(S)*1	MB90V340(S)
Flash Memory	Supports automatic programming, Embedded Algorithm™*3 Write/Erase/Erase-Suspend/Resume commands A flag indicating completion of the algorithm Number of erase cycles : 10,000 times Data retention time : 10 years Boot block configuration Erase can be performed on each block Block protection with external programming voltage Flash Security Feature for protecting the content of the Flash (except for MB90F346/C (S) )	—
ROM Security	Protects the content of ROM (MASK ROM device only)	—

\*1 : The devices other than MB90F342/C (S) , MB90F345/C (S) , MB90F346/C (S) , MB90F347/C (S) , MB90F349/C (S) , MB90346/C (S) and MB90347/C (S) are under development.

\*2 : It is setting of Jumper switch (TOOL V<sub>cc</sub>) when Emulator (MB2147-01) is used.  
Please refer to the Emulator hardware manual about details.

\*3 : Embedded Algorithm is a trade mark of Advanced Micro Devices Inc.

## PIN ASSIGNMENTS

- MB90V340(S)

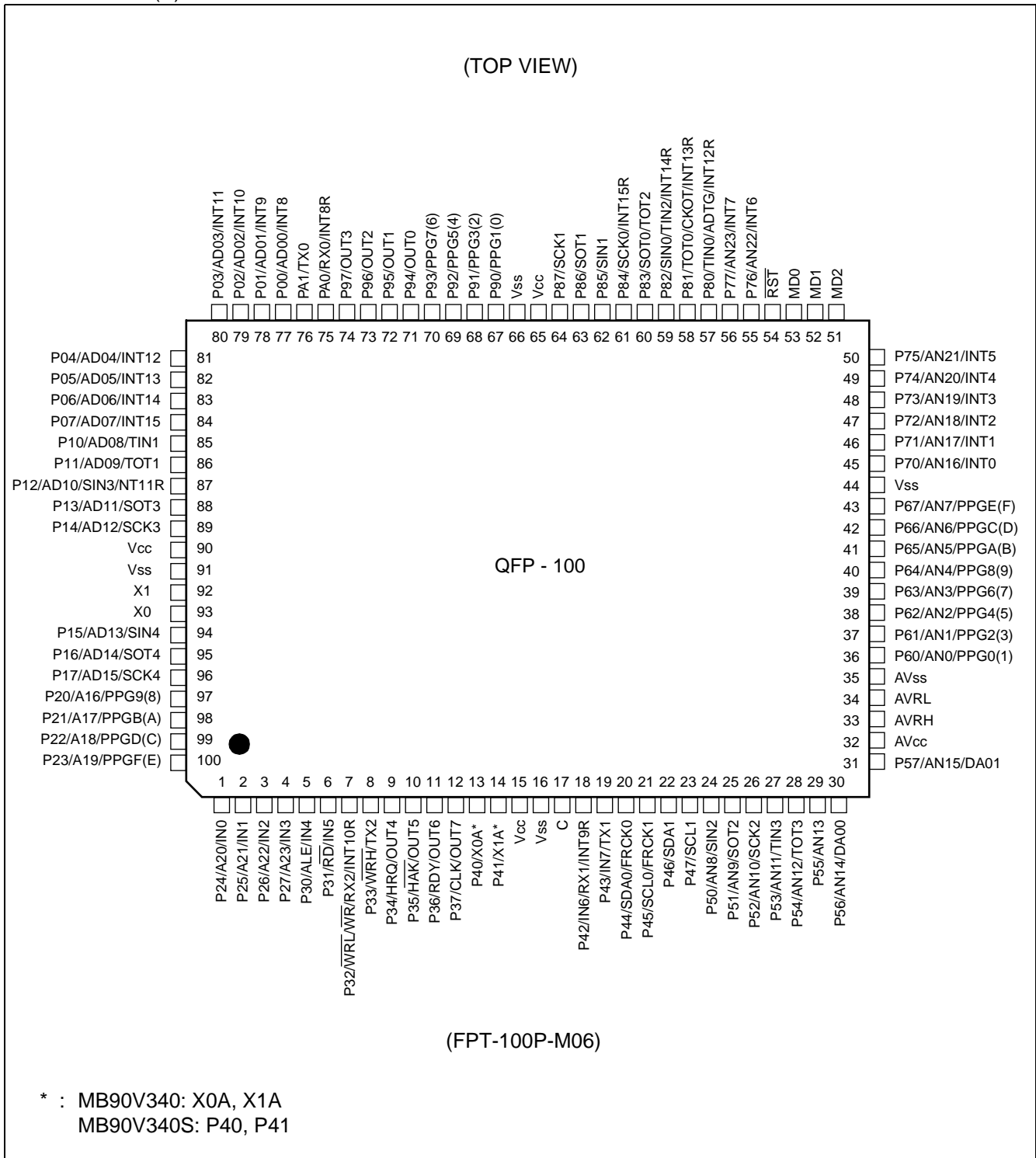

(Continued)

# MB90340 Series

(Continued)

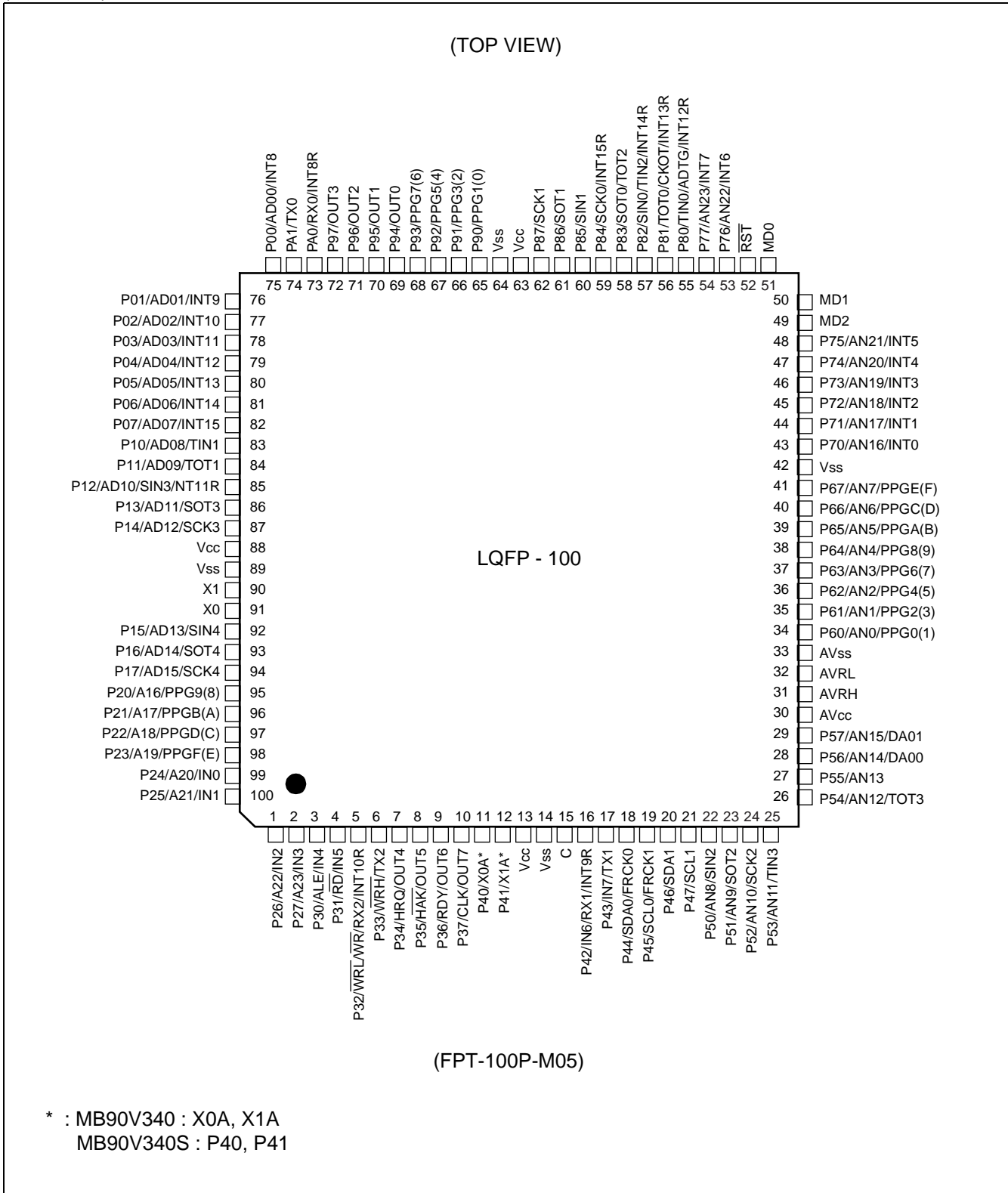



# MB90340 Series

- MB90F342 (S) /MB90F343 (S) /MB90F345 (S) /MB90F346 (S) /MB90F347 (S) /MB90F349 (S) /MB90341 (S) /MB90342 (S) , MB90346 (S) /MB90347 (S) /MB90348 (S) /MB90349 (S)

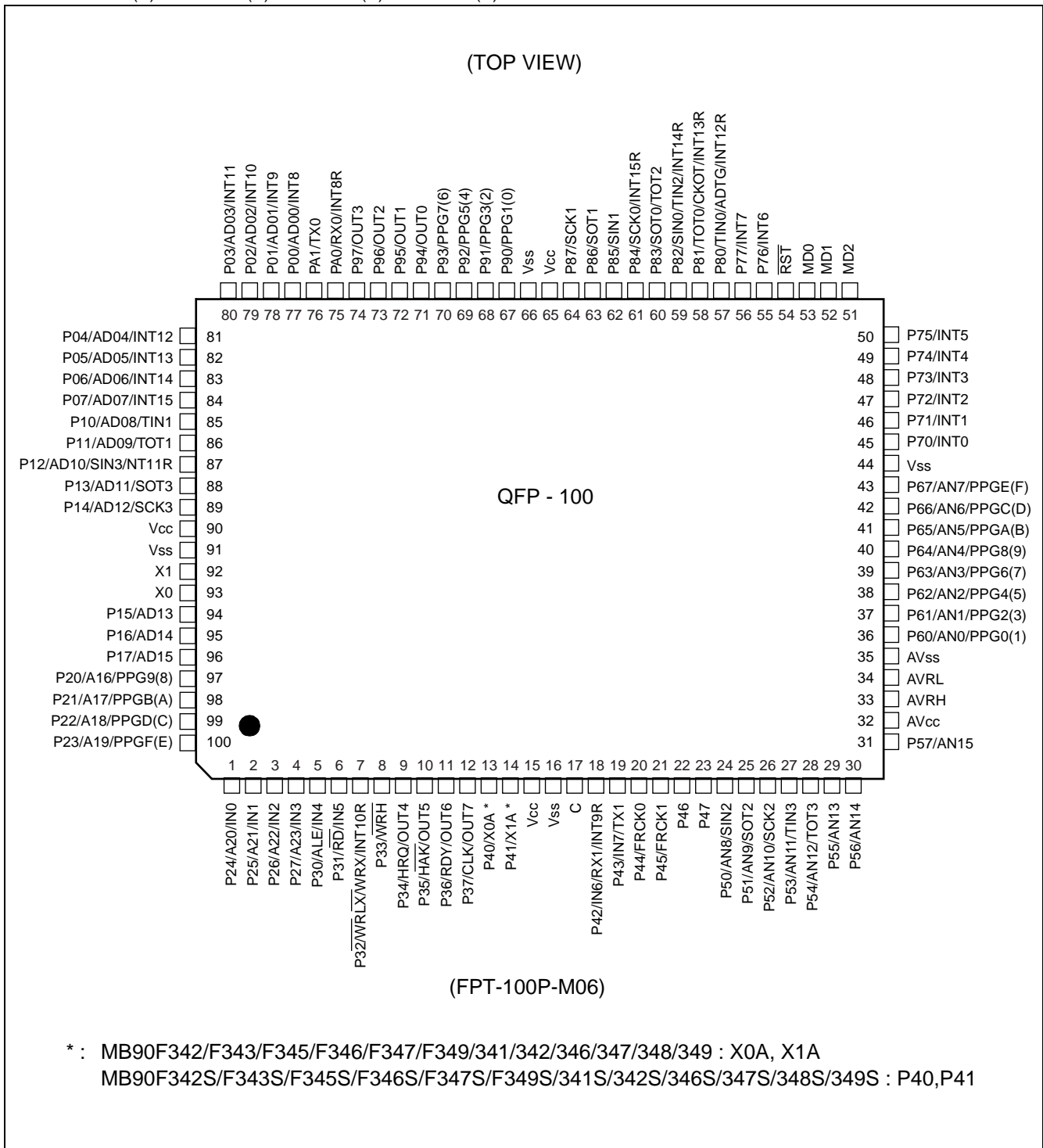

(Continued)

# MB90340 Series

(Continued)

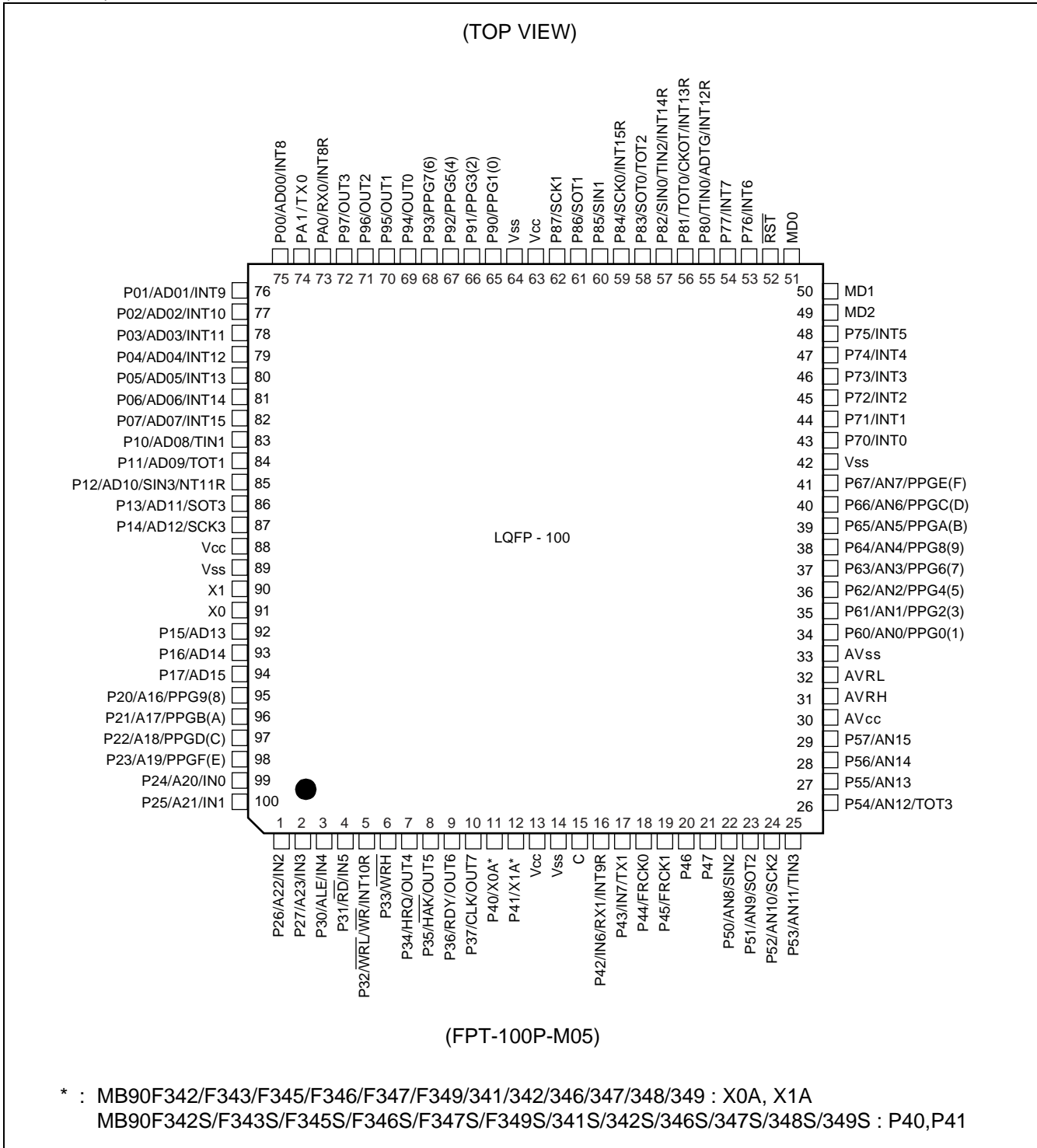

# MB90340 Series

- MB90F342C (S) /MB90F343C (S) /MB90F345C (S) /MB90F346C (S) /MB90F347C (S) /MB90F349C (S) /  
MB90341C (S) /MB90342C (S) ,  
MB90346C (S) /MB90347C (S) /MB90348C (S) /MB90349C (S)

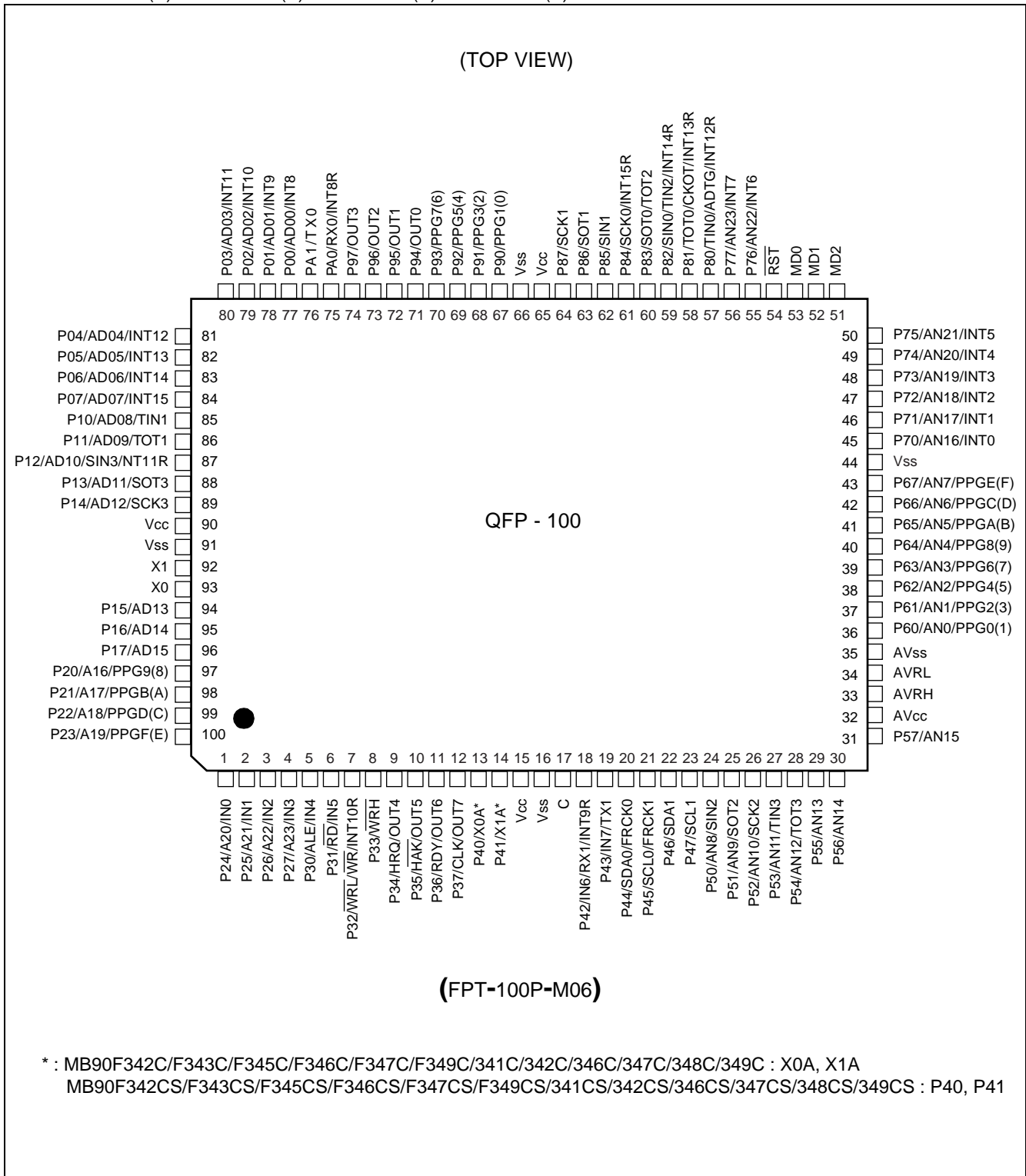

(Continued)

# MB90340 Series

(Continued)

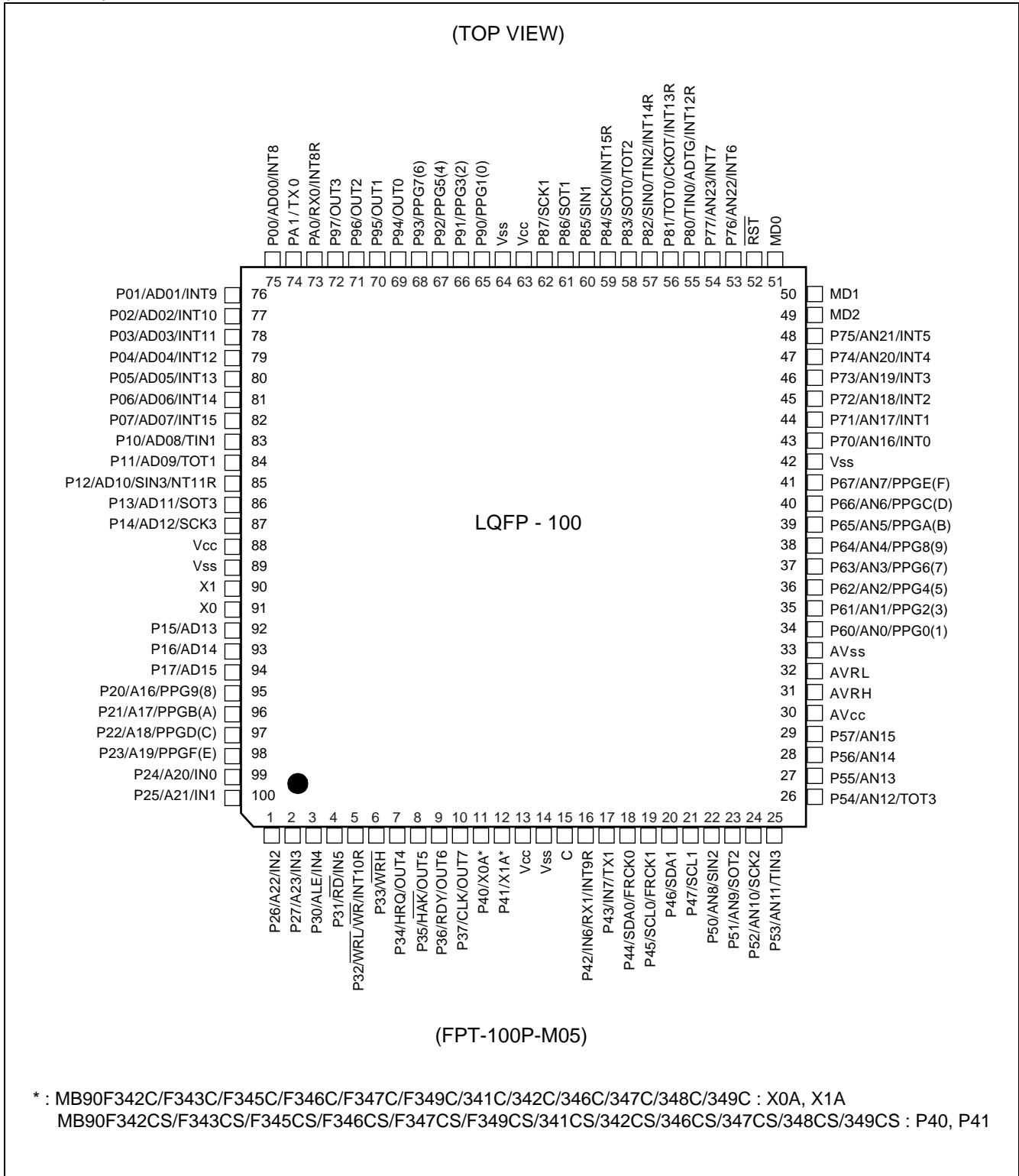

## ■ PIN DESCRIPTION

Pin No.		Pin name	Circuit type	Function
LQFP100*2	QFP100*1			
90	92	X1	A	Oscillation output
91	93	X0		Oscillation input
52	54	$\overline{\text{RST}}$	E	Reset input
75 to 82	77 to 84	P00 to P07	G	General purpose I/O. The register can be set to select whether to use a pull-up resistor. This function is enabled in single-chip mode.
		AD00 to AD07		I/O pins for 8 lower bits of the external address/data bus. This function is enabled when the external bus is enabled.
		INT8 to INT15		External interrupt request input pins for INT8 to INT15.
83	85	P10	G	General purpose I/O. The register can be set to select whether to use a pull-up resistor. This function is enabled in single-chip mode.
		AD08		I/O pin for 8th bit of the external address/data bus. This function is enabled when the external bus is enabled.
		TIN1		Event input pin for the reload timer 1
84	86	P11	G	General purpose I/O. The register can be set to select whether to use a pull-up resistor. This function is enabled in single-chip mode.
		AD09		I/O pin for 9th bit of the external address/data bus. This function is enabled when the external bus is enabled.
		TOT1		Output pin for the reload timer 1
85	87	P12	N	General purpose I/O. The register can be set to select whether to use a pull-up resistor. This function is enabled in single-chip mode.
		AD10		I/O pin for 10th bit of the external address/data bus. This function is enabled when the external bus is enabled.
		SIN3		Serial data input pin for UART3
		INT11R		Sub external interrupt request input pin for INT11
86	88	P13	G	General purpose I/O. The register can be set to select whether to use a pull-up resistor. This function is enabled in single-chip mode.
		AD11		I/O pin for 11th bit of the external address/data bus. This function is enabled when the external bus is enabled.
		SOT3		Serial data output pin for UART3
87	89	P14	G	General purpose I/O. The register can be set to select whether to use a pull-up resistor. This function is enabled in single-chip mode.
		AD12		I/O pin for 12th bit of the external address/data bus. This function is enabled when the external bus is enabled.
		SCK3		Clock I/O pin for UART3

(Continued)

# MB90340 Series

Pin No.		Pin name	Circuit type	Function
LQFP100 <sup>*2</sup>	QFP100 <sup>*1</sup>			
92	94	P15	G	General purpose I/O. The register can be set to select whether to use a pull-up resistor. This function is enabled in single-chip mode.
		AD13		I/O pin for 13th bit of the external address/data bus. This function is enabled when the external bus is enabled.
		SIN4		Serial data input pin for UART4 (MB90V340 only)
93	95	P16	G	General purpose I/O. The register can be set to select whether to use a pull-up resistor. This function is enabled in single-chip mode.
		AD14		I/O pin for 14th bit of the external address/data bus. This function is enabled when the external bus is enabled.
		SOT4		Serial data output pin for UART4 (MB90V340 only)
94	96	P17	G	General purpose I/O. The register can be set to select whether to use a pull-up resistor. This function is enabled in single-chip mode.
		AD15		I/O pin for 15th bit of the external address/data bus. This function is enabled when the external bus is enabled.
		SCK4		Clock I/O pin for UART4 (MB90V340 only)
95 to 98	97 to 100	P20 to P23	G	General purpose I/O. The register can be set to select whether to use a pull-up resistor. In external bus mode, the pin is enabled as a general-purpose I/O port when the corresponding bit in the external address output control register (HACR) is 1.
		A16 to A19		Output pins for A16 to A19 of the external address bus. When the corresponding bit in the external address output control register (HACR) is 0, the pins are enabled as high address output pins (A16 to A19).
		PPG9,PPGB,PPGD,PPGF		Output pins for PPGs
99 to 2	1 to 4	P24 to P27	G	General purpose I/O. The register can be set to select whether to use a pull-up resistor. In external bus mode, the pin is enabled as a general-purpose I/O port when the corresponding bit in the external address output control register (HACR) is 1.
		A20 to A23		Output pins for A20 to A23 of the external address bus. When the corresponding bit in the external address output control register (HACR) is 0, the pins are enabled as high address output pins (A20 to A23).
		IN0 to IN3		Data sample input pins for input captures ICU0 to ICU3
3	5	P30	G	General purpose I/O. The register can be set to select whether to use a pull-up resistor. This function is enabled in single-chip mode.
		ALE		Address latch enable output pin. This function is enabled when the external bus is enabled.
		IN4		Data sample input pin for input capture ICU4

(Continued)

# MB90340 Series

Pin No.		Pin name	Circuit type	Function
LQFP100 <sup>2</sup>	QFP100 <sup>1</sup>			
4	6	P31	G	General purpose I/O. The register can be set to select whether to use a pull-up resistor. This function is enabled in single-chip mode.
		$\overline{RD}$		Read strobe output pin for the data bus. This function is enabled when the external bus is enabled.
		IN5		Data sample input pin for input capture ICU5
5	7	P32	G	General purpose I/O. The register can be set to select whether to use a pull-up resistor. This function is enabled either in single-chip mode or with the $\overline{WR}/\overline{WRL}$ pin output disabled.
		$\overline{WRL} / \overline{WR}$		Write strobe output pin for the data bus. This function is enabled when both the external bus and the $\overline{WR}/\overline{WRL}$ pin output are enabled. $\overline{WRL}$ is used to write-strobe 8 lower bits of the data bus in 16-bit access while $\overline{WR}$ is used to write-strobe 8 bits of the data bus in 8-bit access.
		RX2		RX input pin for CAN2 Interface (MB90V340 only)
		INT10R		Sub external interrupt request input pin for INT10
6	8	P33	G	General purpose I/O. The register can be set to select whether to use a pull-up resistor. This function is enabled either in single-chip mode or with the $\overline{WRH}$ pin output disabled.
		$\overline{WRH}$		Write strobe output pin for the 8 higher bits of the data bus. This function is enabled when the external bus is enabled, when the external bus 16-bit mode is selected, and when the $\overline{WRH}$ output pin is enabled.
		TX2		TX Output pin for CAN2 (MB90V340 only)
7	9	P34	G	General purpose I/O. The register can be set to select whether to use a pull-up resistor. This function is enabled either in single-chip mode or with the hold function disabled.
		HRQ		Hold request input pin. This function is enabled when both the external bus and the hold function are enabled.
		OUT4		Waveform output pin for output compare OCU4
8	10	P35	G	General purpose I/O. The register can be set to select whether to use a pull-up resistor. This function is enabled either in single-chip mode or with the hold function disabled.
		$\overline{HAK}$		Hold acknowledge output pin. This function is enabled when both the external bus and the hold function are enabled.
		OUT5		Waveform output pin for output compare OCU6
9	11	P36	G	General purpose I/O. The register can be set to select whether to use a pull-up resistor. This function is enabled either in single-chip mode or with the external ready function disabled.
		RDY		Ready input pin. This function is enabled when both the external bus and the external ready function are enabled.
		OUT6		Waveform output pin for output compare OCU5

(Continued)

# MB90340 Series

Pin No.		Pin name	Circuit type	Function
LQFP100 <sup>*2</sup>	QFP100 <sup>*1</sup>			
10	12	P37	G	General purpose I/O. The register can be set to select whether to use a pull-up resistor. This function is enabled either in single-chip mode or with the CLK output disabled.
		CLK		CLK output pin. This function is enabled when both the external bus and CLK output are enabled.
		OUT7		Waveform output pin for output compare OCU7
11 to 12	13 to 14	P40 to P41	F	General purpose I/O (devices with S-suffix)
		X0A , X1A	B	Oscillator input pins for sub-clock (devices without S-suffix)
16	18	P42	F	General purpose I/O
		IN6		Data sample input pin for input capture ICU6
		RX1		RX input pin for CAN1 Interface (MB90F342/F343/F345/341/342 only)
		INT9R		Sub external interrupt request input pin for INT10
17	19	P43	F	General purpose I/O
		IN7		Data sample input pin for input capture ICU7
		TX1		TX Output pin for CAN1 (MB90F342/F343/F345/341/342 only)
18	20	P44	H	General purpose I/O
		SDA0		Serial data I/O pin for I2C 0 (devices with C-suffix)
		FRCK0		Input for the 16-bit I/O Timer 0
19	21	P45	H	General purpose I/O
		SCL0		Serial clock I/O pin for I2C 0 (devices with C-suffix)
		FRCK1		Input for the 16-bit I/O Timer 1
20	22	P46	H	General purpose I/O
		SDA1		Serial data I/O pin for I2C 1 (devices with C-suffix)
21	23	P47	H	General purpose I/O
		SCL1		Serial clock I/O pin for I <sup>2</sup> C 1 (devices with C-suffix)
22	24	P50	O	General purpose I/O
		AN8		Analog input pin for the A/D converter
		SIN2		Serial data input pin for UART2
23	25	P51	I	General purpose I/O
		AN9		Analog input pin for the A/D converter
		SOT2		Serial data output pin for UART2
24	26	P52	I	General purpose I/O
		AN10		Analog input pin for the A/D converter
		SCK2		Clock I/O pin for UART2
25	27	P53	I	General purpose I/O
		AN11		Analog input pin for the A/D converter
		TIN3		Event input pin for the reload timers 3

(Continued)



# MB90340 Series

Pin No.		Pin name	Circuit type	Function
LQFP100*2	QFP100*1			
26	28	P54	I	General purpose I/O
		AN12		Analog input pin for the A/D converter
		TOT3		Output pin for the reload timer 3
27	29	P55	I	General purpose I/O
		AN13		Analog input pin for the A/D converter
28, 29	30, 31	P56 to P57	J	General purpose I/O
		AN14 to AN15		Analog input pin for the A/D converter
		DA00 to DA01		D/A converter analog output pins (MB90V340 only)
34 to 41	36 to 43	P60 to P67	I	General purpose I/O
		AN0 to AN7		Analog input pins for the A/D converter
		PPG0, 2, 4, 6, 8, A, C, E		Output pins for PPGs
43 to 48, 53, 54	45 to 50, 55, 56	P70 to P77	I	General purpose I/O
		AN16 to AN23		Analog input pins for the A/D converter (devices with C-suffix)
		INT0 to INT7		External interrupt request input pins for INT0 to INT7
55	57	P80	F	General purpose I/O
		TIN0		Event input pin for the reload timers 0
		ADTG		Trigger input pin for the A/D converter
		INT12R		Sub external interrupt request input pin for INT12
56	58	P81	F	General purpose I/O
		TOT0		Output pin for the reload timer 0
		CKOT		Output pin for the clock monitor
		INT13R		Sub external interrupt request input pin for INT13
57	59	P82	M	General purpose I/O
		SIN0		Serial data input pin for UART0
		TIN2		Event input pin for the reload timers 2
		INT14R		Sub external interrupt request input pin for INT14
58	60	P83	F	General purpose I/O
		SOT0		Serial data output pin for UART0
		TOT2		Output pin for the reload timer 2
59	61	P84	F	General purpose I/O
		SCK0		Clock I/O pin for UART0
		INT15R		Sub external interrupt request input pin for INT15
60	62	P85	M	General purpose I/O
		SIN1		Serial data input pin for UART1
61	63	P86	F	General purpose I/O
		SOT1		Serial data output pin for UART1

(Continued)

# MB90340 Series

(Continued)

Pin No.		Pin name	Circuit type	Function
LQFP100 <sup>*2</sup>	QFP100 <sup>*1</sup>			
62	64	P87	F	General purpose I/O
		SCK1		Clock I/O pin for UART1
65 to 68	67 to 70	P90 to P93	F	General purpose I/O
		PPG1, 3, 5, 7		Output pins for PPGs
69 to 72	71 to 74	P94 to P97	F	General purpose I/O
		OUT0 to OUT3		Waveform output pins for output compares OCU0 to OCU3. This function is enabled when the OCU enables waveform output.
73	75	PA0	F	General purpose I/O
		RX0		RX input pin for CAN0 Interface
		INT8R		Sub external interrupt request input pin for INT8
74	76	PA1	F	General purpose I/O
		TX0		TX Output pin for CAN0
30	32	AV <sub>cc</sub>	K	V <sub>cc</sub> power input pin for analog circuits
31	33	AVRH	L	Reference voltage input for the A/D Converter. This power supply must be turned on or off while a voltage higher than or equal to AVRH is applied to AV <sub>cc</sub> .
32	34	AVRL	K	Lower reference voltage input for the A/D Converter
33	35	AV <sub>ss</sub>	K	V <sub>ss</sub> power input pin for analog circuits
50, 51	52, 53	MD1, MD0	C	Input pins for specifying the operating mode. The pins must be directly connected to V <sub>cc</sub> or V <sub>ss</sub>
49	51	MD2	D	Input pin for specifying the operating mode. The pins must be directly connected to V <sub>cc</sub> or V <sub>ss</sub> .
13 63 88	15 65 90	V <sub>cc</sub>	—	Power (3.5 V to 5.5 V) input pins
14 42 64 89	16 44 66 91	V <sub>ss</sub>	—	Power (0V) input pins
15	17	C	K	This is the power supply stabilization capacitor pin. It should be connected to a higher than or equal to 0.1 μF ceramic capacitor.

\*1 : FPT-100P-M06

\*2 : FPT-100P-M05

## ■ I/O CIRCUIT TYPE

Type	Circuit	Remarks
A		<p>Oscillation circuit</p> <ul style="list-style-type: none"> <li>High-speed oscillation feedback resistor = approx. 1 M<math>\Omega</math></li> </ul>
B		<p>Oscillation circuit</p> <ul style="list-style-type: none"> <li>Low-speed oscillation feedback resistor = approx. 1 M<math>\Omega</math></li> </ul>
C		<p>Mask ROM and EVA device:</p> <ul style="list-style-type: none"> <li>CMOS Hysteresis input pin</li> <li>Resistor value : approx. 50 k<math>\Omega</math> (Typ)</li> </ul> <p>Flash device:</p> <ul style="list-style-type: none"> <li>CMOS input pin</li> <li>Resistor value : approx. 50 k<math>\Omega</math> (Typ)</li> </ul>
D		<p>Mask ROM and EVA device:</p> <ul style="list-style-type: none"> <li>CMOS Hysteresis input pin</li> <li>Resistor value : approx. 50 k<math>\Omega</math> (Typ)</li> <li>Pull-down resistor valule: approx. 50 k<math>\Omega</math></li> </ul> <p>Flash device:</p> <ul style="list-style-type: none"> <li>CMOS input pin</li> <li>Resistor value : approx. 50 k<math>\Omega</math> (Typ)</li> <li>No Pull-down</li> </ul>
E		<p>CMOS Hysteresis input pin</p> <ul style="list-style-type: none"> <li>Resistor value : approx. 50 k<math>\Omega</math> (Typ)</li> <li>Pull-up resistor valule: approx. 50 k<math>\Omega</math></li> </ul>

(Continued)

# MB90340 Series

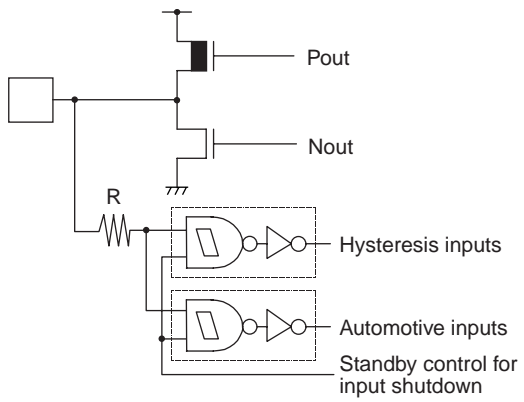
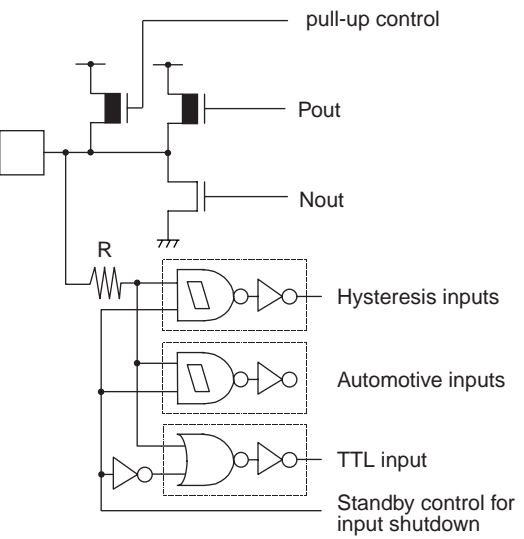
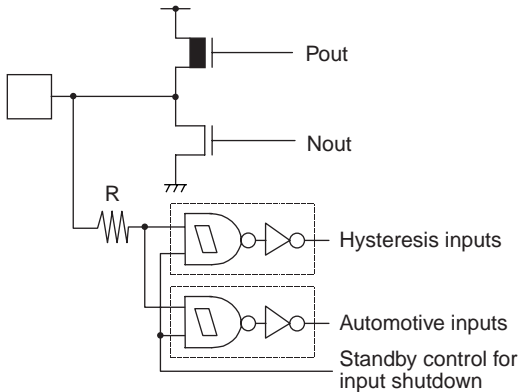
Type	Circuit	Remarks
F	 <p>The diagram for Type F shows a CMOS output stage with a PMOS transistor (Pout) and an NMOS transistor (Nout). A pull-up resistor R is connected to the input of the PMOS transistor. The input is also connected to two input stages: Hysteresis inputs and Automotive inputs. A standby control input is also shown.</p>	<ul style="list-style-type: none"> <li>• CMOS level output(<math>I_{OL} = 4 \text{ mA}</math>)</li> <li>• CMOS hysteresis inputs (With the standby-time input shutdown function)</li> <li>• Automotive input (With the standby-time input shutdown function)</li> </ul>
G	 <p>The diagram for Type G shows a CMOS output stage with a PMOS transistor (Pout) and an NMOS transistor (Nout). A pull-up resistor R is connected to the input of the PMOS transistor. The input is also connected to three input stages: Hysteresis inputs, Automotive inputs, and TTL input. A pull-up control input and a standby control input are also shown.</p>	<ul style="list-style-type: none"> <li>• CMOS level output(<math>I_{OL} = 4 \text{ mA}</math>)</li> <li>• CMOS hysteresis inputs (With the standby-time input shutdown function)</li> <li>• Automotive input (With the standby-time input shutdown function)</li> <li>• TTL input (With the standby-time input shutdown function)</li> <li>• Programmable pullup resistor: <math>50 \text{ k}\Omega</math> approx.</li> </ul>
H	 <p>The diagram for Type H shows a CMOS output stage with a PMOS transistor (Pout) and an NMOS transistor (Nout). A pull-up resistor R is connected to the input of the PMOS transistor. The input is also connected to two input stages: Hysteresis inputs and Automotive inputs. A standby control input is also shown.</p>	<ul style="list-style-type: none"> <li>• CMOS level output(<math>I_{OL} = 3 \text{ mA}</math>)</li> <li>• CMOS hysteresis inputs (With the standby-time input shutdown function)</li> <li>• Automotive input (With the standby-time input shutdown function)</li> </ul>

(Continued)

# MB90340 Series

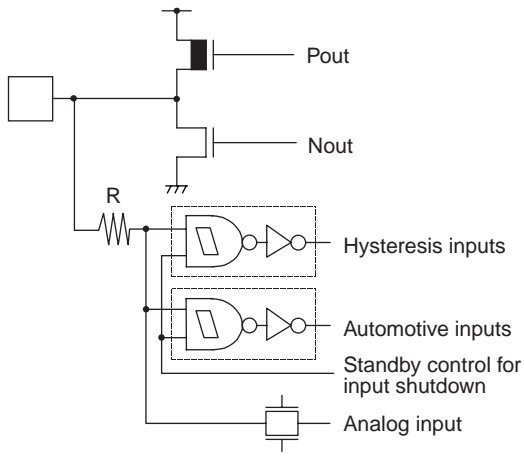
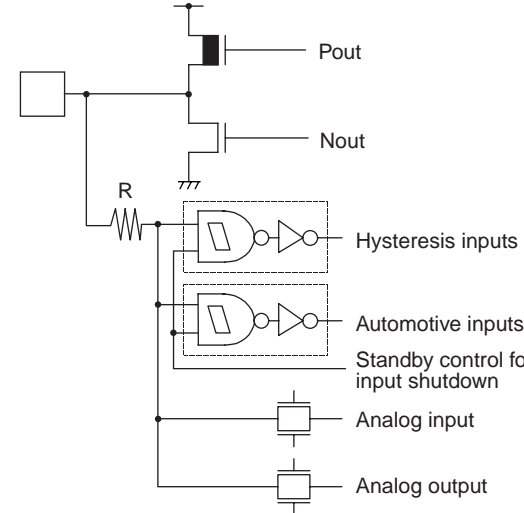
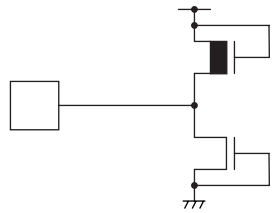
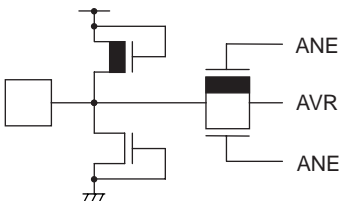
Type	Circuit	Remarks
I		<ul style="list-style-type: none"> <li>• CMOS level output(<math>I_{OL} = 4 \text{ mA}</math>)</li> <li>• CMOS hysteresis inputs (With the standby-time input shutdown function)</li> <li>• Automotive input (With the standby-time input shutdown function)</li> <li>• A/D analog input</li> </ul>
J		<ul style="list-style-type: none"> <li>• CMOS level output(<math>I_{OL} = 4 \text{ mA}</math>)</li> <li>• D/A analog output</li> <li>• CMOS hysteresis inputs (With the standby-time input shutdown function)</li> <li>• Automotive input (With the standby-time input shutdown function)</li> <li>• A/D analog input</li> </ul>
K		<ul style="list-style-type: none"> <li>• Power supply input protection circuit</li> </ul>
L		<ul style="list-style-type: none"> <li>• A/D converter reference voltage power supply input pin, with the protection circuit</li> <li>• Flash devices do not have a protection circuit against <math>V_{CC}</math> for pin AVRH</li> </ul>

(Continued)

# MB90340 Series

(Continued)

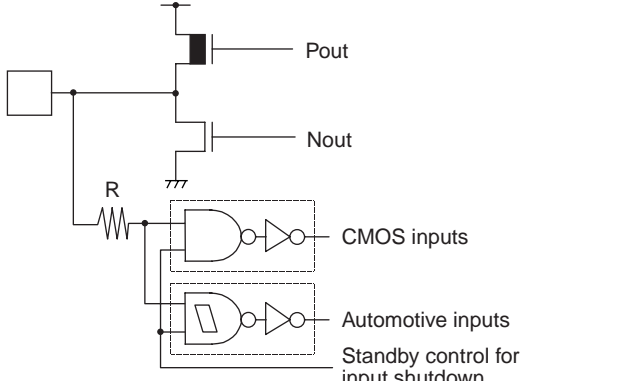
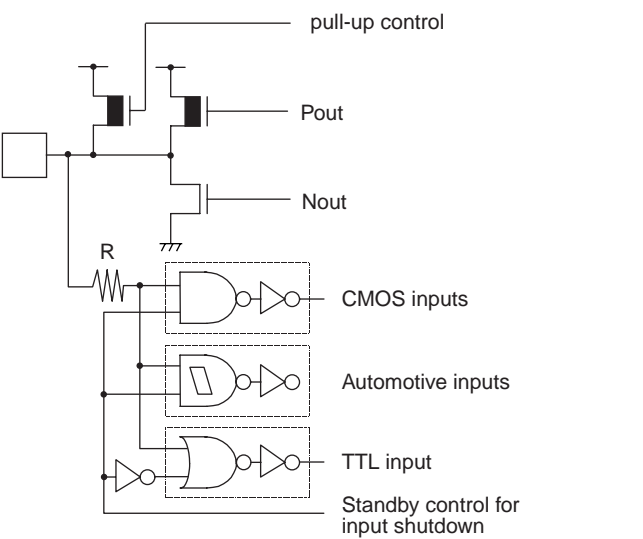
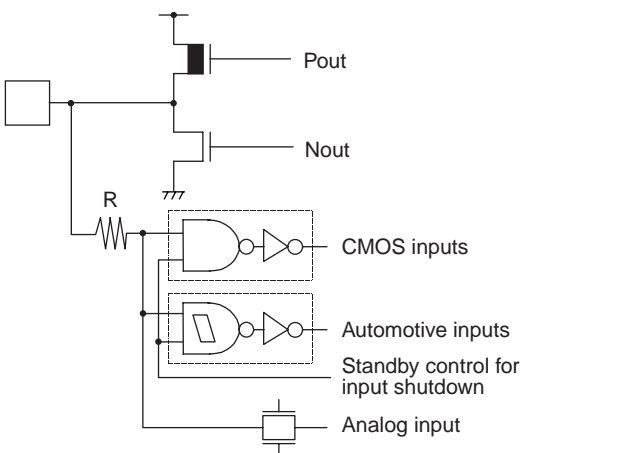
Type	Circuit	Remarks
M	 <p>The diagram for Type M shows a pull-up resistor R connected to the input of CMOS and Automotive inputs. The output stage consists of PMOS (Pout) and NMOS (Nout) transistors. Standby control for input shutdown is also shown.</p>	<ul style="list-style-type: none"> <li>• CMOS level output(<math>I_{OL} = 4 \text{ mA}</math>)</li> <li>• CMOS inputs (With the standby-time input shutdown function)</li> <li>• Automotive input (With the standby-time input shutdown function)</li> </ul>
N	 <p>The diagram for Type N shows a pull-up resistor R and a pull-up control signal. The input stage includes CMOS, Automotive, and TTL inputs. The output stage consists of PMOS (Pout) and NMOS (Nout) transistors. Standby control for input shutdown is also shown.</p>	<ul style="list-style-type: none"> <li>• CMOS level output(<math>I_{OL} = 4 \text{ mA}</math>)</li> <li>• CMOS inputs (With the standby-time input shutdown function)</li> <li>• Automotive input (With the standby-time input shutdown function)</li> <li>• TTL input (With the standby-time input shutdown function)</li> </ul> <p>Programmable pullup resistor: 50 k<math>\Omega</math> approx</p>
O	 <p>The diagram for Type O shows a pull-up resistor R and an analog input. The input stage includes CMOS and Automotive inputs. The output stage consists of PMOS (Pout) and NMOS (Nout) transistors. Standby control for input shutdown is also shown.</p>	<ul style="list-style-type: none"> <li>• CMOS level output(<math>I_{OL} = 4 \text{ mA}</math>)</li> <li>• CMOS inputs (With the standby-time input shutdown function)</li> <li>• Automotive input (With the standby-time input shutdown function)</li> <li>• A/D analog input</li> </ul>

## ■ HANDLING DEVICES

Special care is required for the following when handling the device :

- Preventing latch-up
- Treatment of unused pins
- Using external clock
- Precautions for when not using a sub clock signal
- Notes on during operation of PLL clock mode
- Power supply pins ( $V_{CC}/V_{SS}$ )
- Pull-up/down resistors
- Crystal Oscillator Circuit
- Turning-on Sequence of Power Supply to A/D Converter and Analog Inputs
- Connection of Unused Pins of A/D Converter
- Notes on Energization
- Stabilization of power supply voltage
- Initialization
- Port0 to port3 output during Power-on(**External-bus mode**)
- Notes on using CAN Function
- Flash security Function

### 1. Preventing latch-up

**CMOS IC chips may suffer latch-up under the following conditions :**

- A voltage higher than  $V_{CC}$  or lower than  $V_{SS}$  is applied to an input or output pin.
- A voltage higher than the rated voltage is applied between  $V_{CC}$  and  $V_{SS}$ .
- The  $AV_{CC}$  power supply is applied before the  $V_{CC}$  voltage.

Latch-up may increase the power supply current drastically, causing thermal damage to the device.

For the same reason, also be careful not to let the analog power-supply voltage ( $AV_{CC}$ ,  $AV_{RH}$ ) exceed the digital power-supply voltage.

### 2. Handling unused pins

Leaving unused input pins open may result in misbehavior or latch up and possible permanent damage of the device. Therefore they must be pulled up or pulled down through resistors. In this case those resistors should be more than 2 k $\Omega$  .

Unused bidirectional pins should be set to the output state and can be left open, or the input state with the above described connection.

### 3. Using external clock

To use external clock, drive the X0 pin and leave X1 pin open.

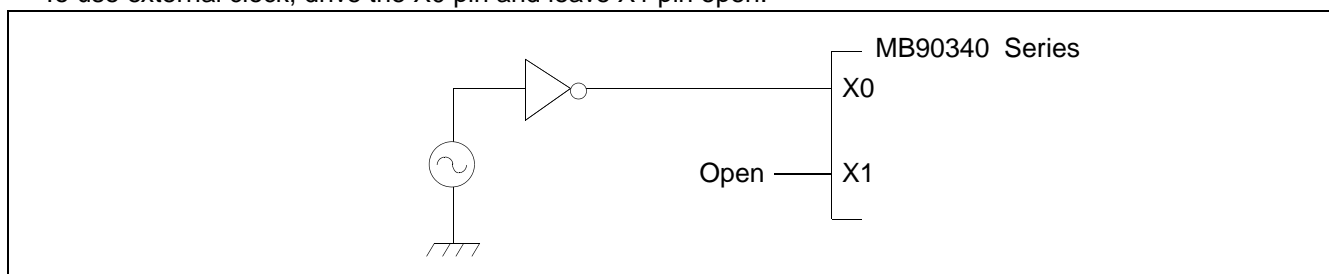

### 4. Precautions for when not using a sub clock signal

If you do not connect pins X0A and X1A to an oscillator, use pull-down handling on the X0A pin, and leave the X1A pin open.

# MB90340 Series

## 5. Notes on during operation of PLL clock mode

If the PLL clock mode is selected, the microcontroller attempt to be working with the self-oscillating circuit even when there is no external oscillator or external clock input is stopped. Performance of this operation, however, cannot be guaranteed.

## 6. Power supply pins ( $V_{CC}/V_{SS}$ )

- If there are multiple  $V_{CC}$  and  $V_{SS}$  pins, from the point of view of device design, pins to be of the same potential are connected the inside of the device to prevent such malfunctioning as latch up.  
To reduce unnecessary radiation, prevent malfunctioning of the strobe signal due to the rise of ground level, and observe the standard for total output current, be sure to connect the  $V_{CC}$  and  $V_{SS}$  pins to the power supply and ground externally.
- Connect  $V_{CC}$  and  $V_{SS}$  to the device from the current supply source at a low impedance.
- As a measure against power supply noise, connect a capacitor of about 0.1  $\mu\text{F}$  as a bypass capacitor between  $V_{CC}$  and  $V_{SS}$  in the vicinity of  $V_{CC}$  and  $V_{SS}$  pins of the device

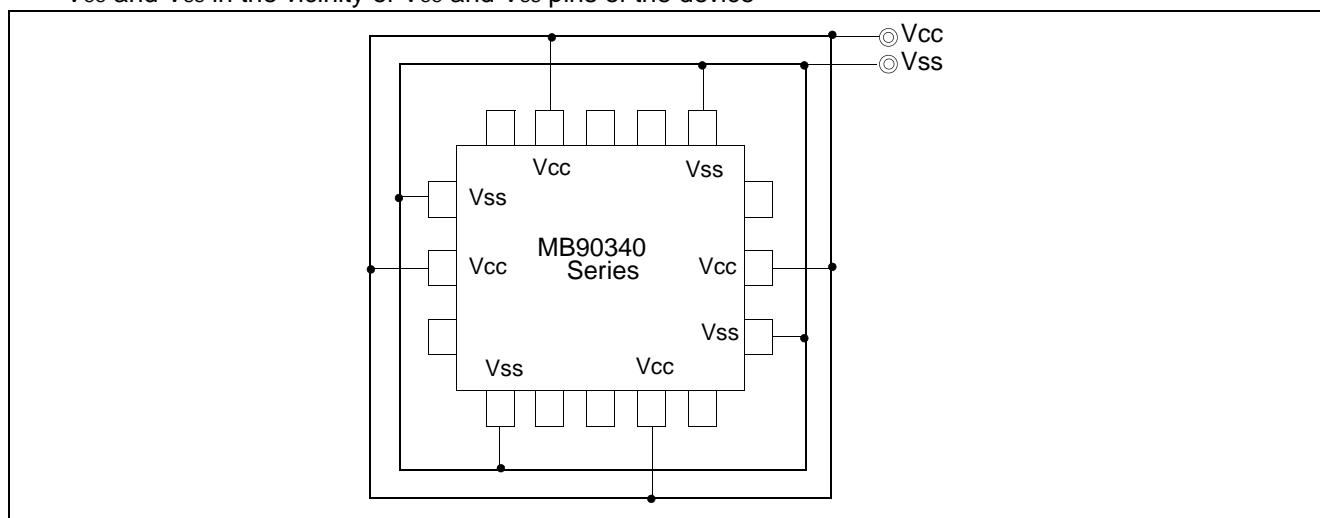

## 7. Pull-up/down resistors

The MB90340 Series does not support internal pull-up/down resistors (Port 0 to Port 3: built-in pull-up resistors). Use external components where needed.

## 8. Crystal Oscillator Circuit

Noises around X0 or X1 pins may be possible causes of abnormal operations. Make sure to provide bypass capacitors via shortest distance from X0, X1 pins, crystal oscillator (or ceramic resonator) and ground lines, and make sure, to the utmost effort, that lines of oscillation circuit not cross the lines of other circuits.

It is highly recommended to provide a printed circuit board art work surrounding X0 and X1 pins with a ground area for stabilizing the operation.

## 9. Turning-on Sequence of Power Supply to A/D Converter and Analog Inputs

Make sure to turn on the A/D converter power supply ( $AV_{CC}$ ,  $AV_{RH}$ ,  $AV_{RL}$ ) and analog inputs (AN0 to AN14) after turning-on the digital power supply ( $V_{CC}$ ).

Turn-off the digital power after turning off the A/D converter supply and analog inputs. In this case, make sure that the voltage not exceed  $AV_{RH}$  or  $AV_{CC}$  (turning on/off the analog and digital power supplies simultaneously is acceptable).

## 10. Connection of Unused Pins of A/D Converter if A/D Converter is used

Connect unused pins of A/D converter to  $AV_{CC} = V_{CC}$ ,  $AV_{SS} = AV_{RH} = AV_{RL} = V_{SS}$ .



## 11. Notes on Energization

To prevent the internal regulator circuit from malfunctioning, set the voltage rise time during energization at 50 or more  $\mu\text{s}$  (0.2 V to 2.7 V)

## 12. Stabilization of power supply voltage

A sudden change in the supply voltage may cause the device to malfunction even within the specified  $V_{CC}$  supply voltage operating range. Therefore, the  $V_{CC}$  supply voltage should be stabilized.

For reference, the supply voltage should be controlled so that  $V_{CC}$  ripple variations (peak-to-peak value) at commercial frequencies (50 Hz to 60 Hz) fall below 10% of the standard  $V_{CC}$  supply voltage and the coefficient of fluctuation does not exceed 0.1 V/ms at instantaneous power switching.

## 13. Initialization

In the device, there are internal registers which are initialized only by a power-on reset. To initialize these registers, turn on the power again.

## 14. Port 0 to port 3 output during Power-on (External-bus mode)

As shown below, when power is turned on in External-Bus mode, there is a possibility that output signal of Port 0 to Port 3 might be unstable.

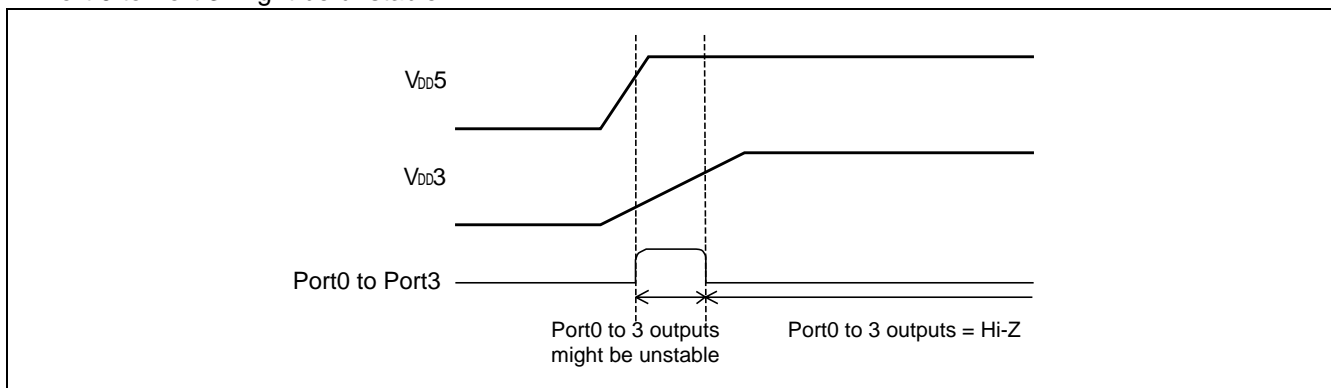

## 15. Notes on using CAN Function

To use CAN function, please set '1' to DIRECT bit of CAN Direct Mode Register (CDMR).  
If DIRECT bit is set to '0' (initial value), wait states will be performed when accessing CAN registers.  
Please refer to Hardware Manual of MB90340 series for detail of CAN Direct Mode Register.

## 16. Flash security Function (except for MB90F346)

The security bit is located in the area of the flash memory.  
If protection code 01<sub>H</sub> is written in the security bit, the flash memory is in the protected state by security.  
Therefore please do not write 01<sub>H</sub> in this address if you do not use the security function.  
Please refer to following table for the address of the security bit.

	Flash memory size	Address for security bit
MB90F347	Embedded 1 Mbit Flash Memory	FE0001 <sub>H</sub>
MB90F342 MB90F349	Embedded 2 Mbit Flash Memory	FC0001 <sub>H</sub>
MB90F343	Embedded 3 Mbit Flash Memory	F90001 <sub>H</sub>
MB90F345	Embedded 4 Mbit Flash Memory	F80001 <sub>H</sub>

# MB90340 Series

## ■ BLOCK DIAGRAMS

### MB90V340(S)

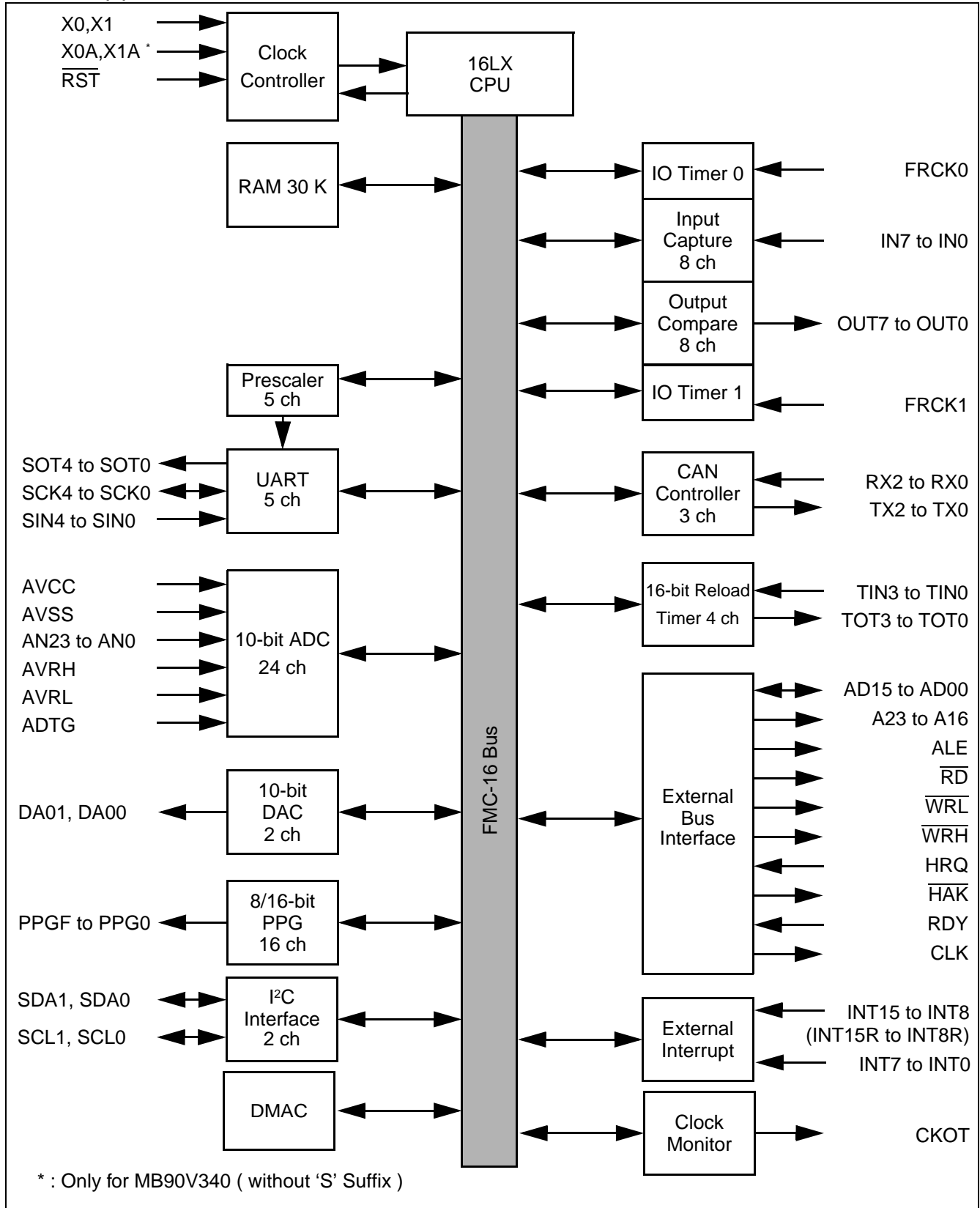

# MB90340 Series

MB90F342/C (S) , MB90F343/C (S) , MB90F345/C (S) , MB90F346/C (S) , MB90F347/C (S) , MB90F349/C (S) ,  
 MB90341/C (S) , MB90342/C (S) , MB90346/C (S) , MB90347/C (S) , MB90348/C (S) , MB90349/C (S)

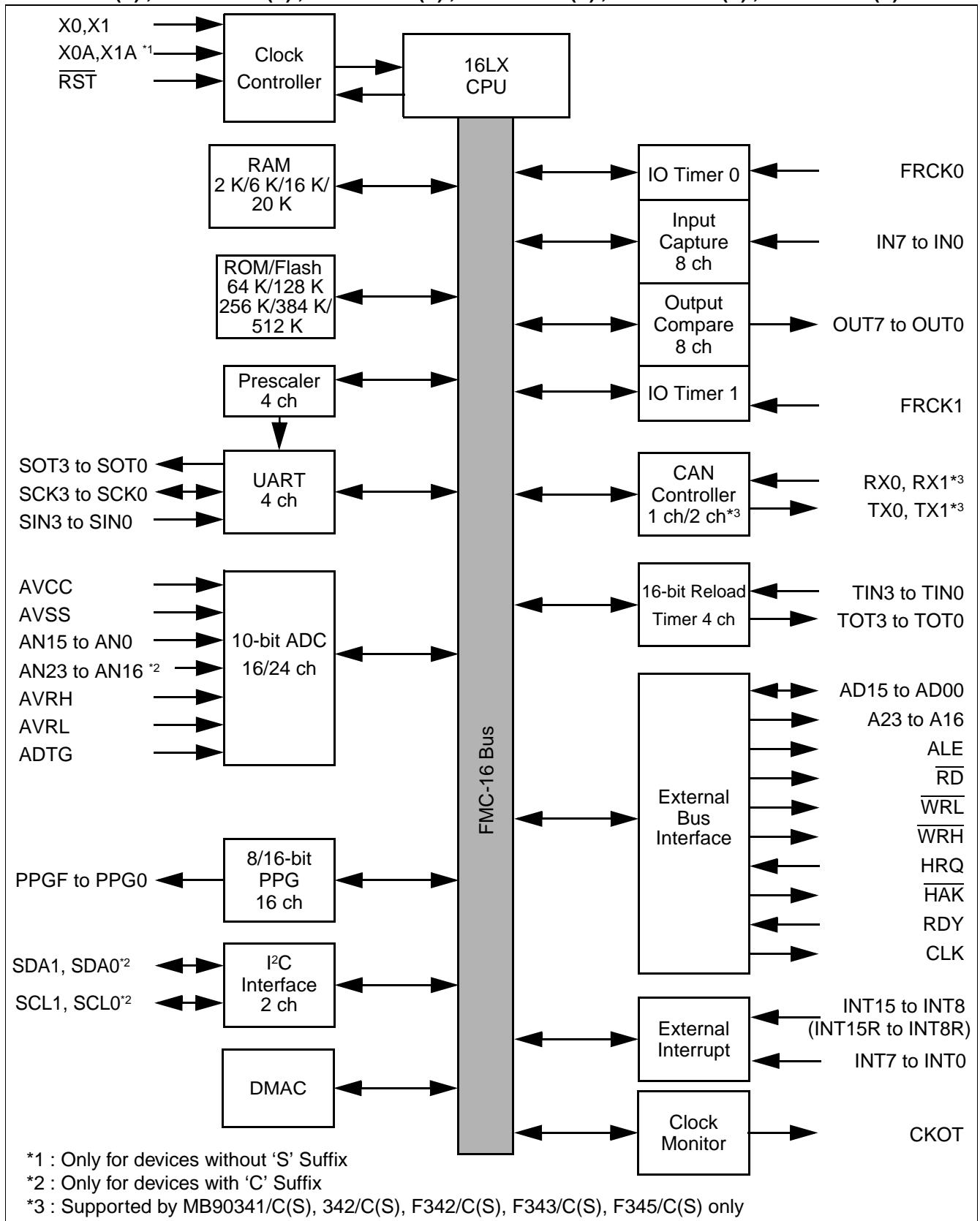

# MB90340 Series

## MEMORY MAP

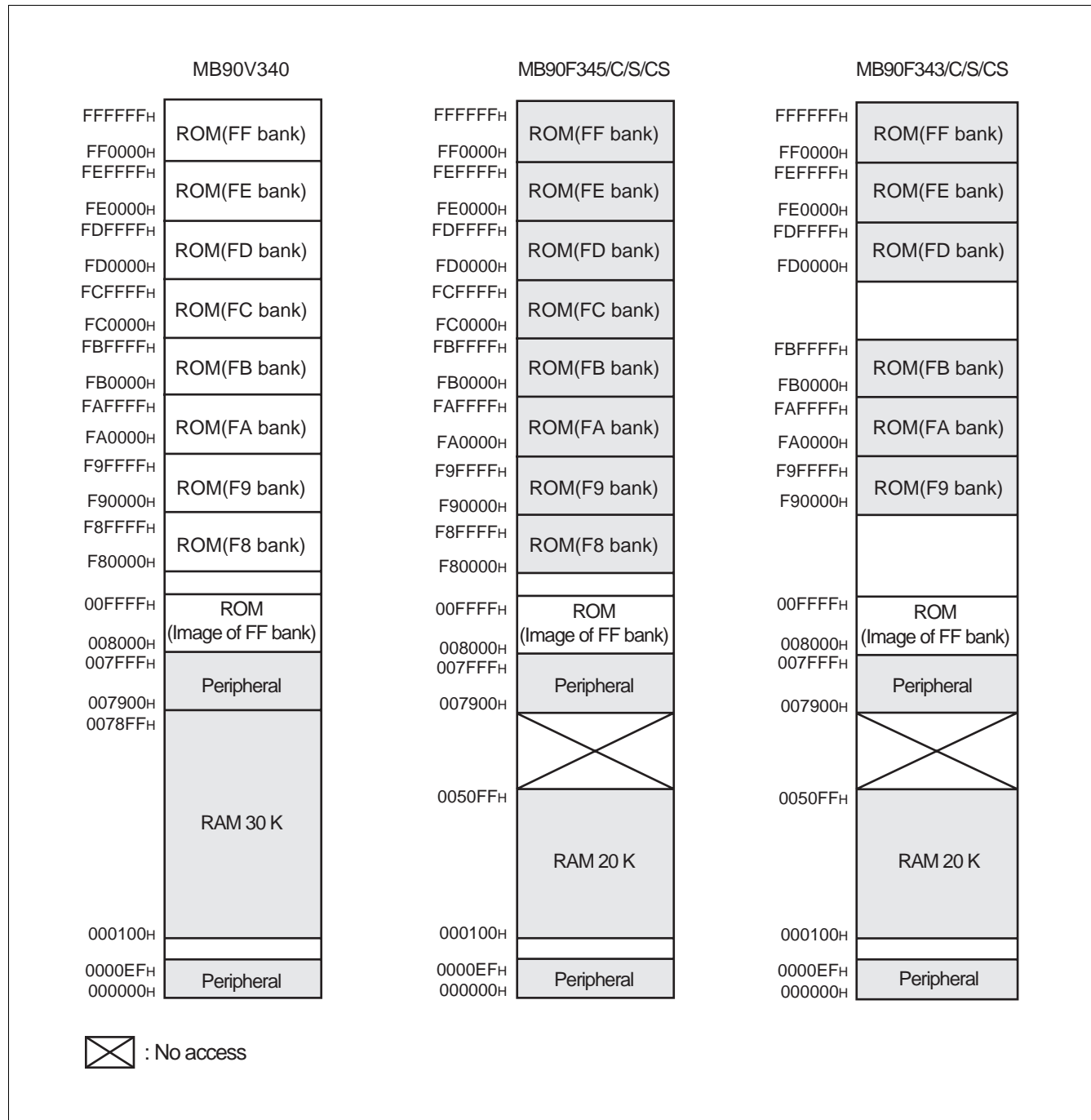

# MB90340 Series

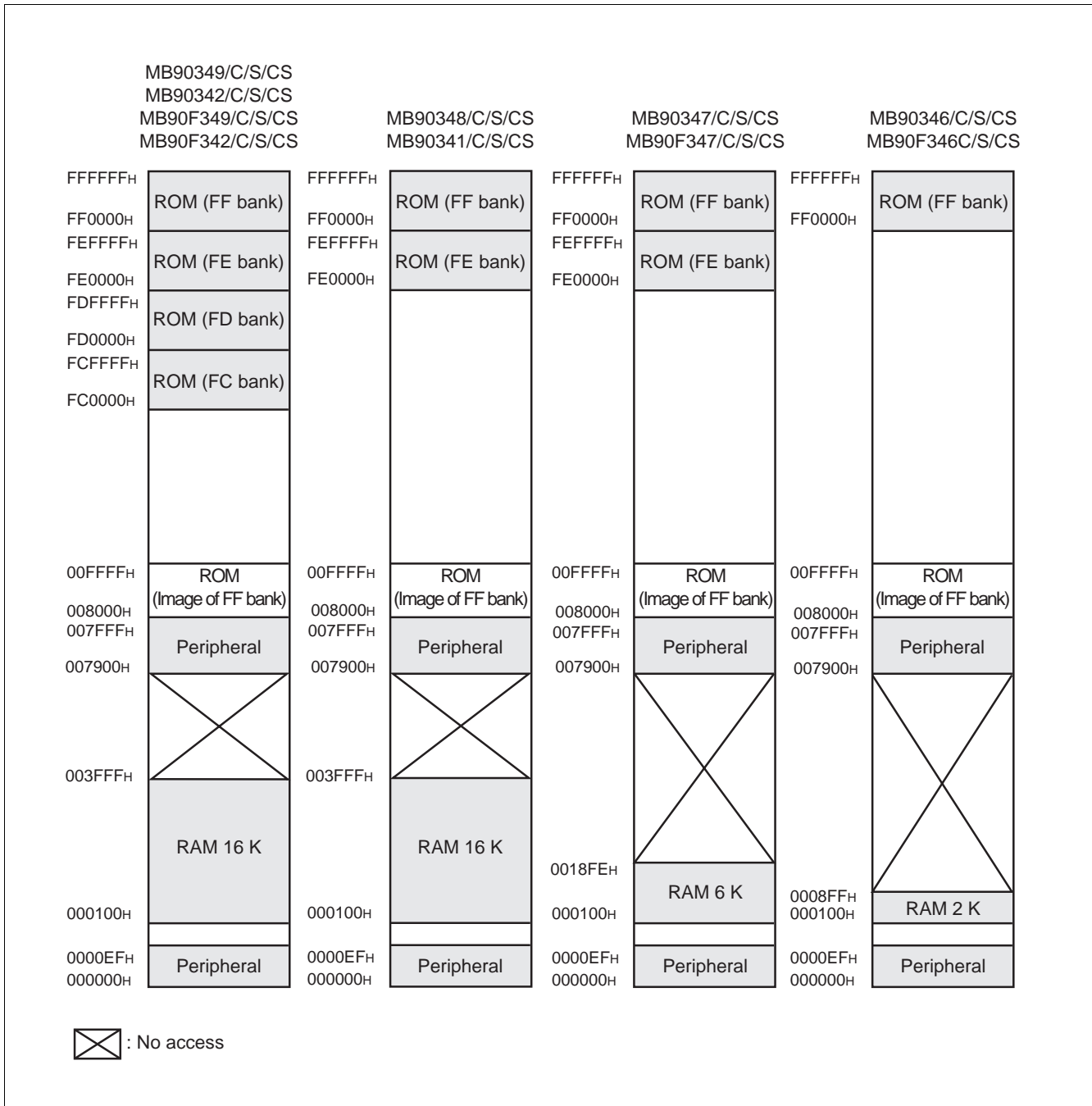

Note : The high-order portion of bank 00 gives the image of the FF bank ROM to make the small model of the C compiler effective. Since the low-order 16 bits are the same, the table in ROM can be referenced without using the far specification in the pointer declaration.

For example, an attempt to access 00C000H accesses the value at FFC000H in ROM.

The ROM area in bank FF exceeds 32 Kbytes, and its entire image cannot be shown in bank 00.

The image between FF8000H and FFFFFFFH is visible in bank 00, while the image between FF0000H and FF7FFFH is visible only in bank FF.

# MB90340 Series

## ■ I/O MAP

Address	Register	Abbrevia- tion	Access	Resource name	Initial value
00 <sub>H</sub>	Port 0 data register	PDR0	R/W	Port 0	XXXXXXXX
01 <sub>H</sub>	Port 1 data register	PDR1	R/W	Port 1	XXXXXXXX
02 <sub>H</sub>	Port 2 data register	PDR2	R/W	Port 2	XXXXXXXX
03 <sub>H</sub>	Port 3 data register	PDR3	R/W	Port 3	XXXXXXXX
04 <sub>H</sub>	Port 4 data register	PDR4	R/W	Port 4	XXXXXXXX
05 <sub>H</sub>	Port 5 data register	PDR5	R/W	Port 5	XXXXXXXX
06 <sub>H</sub>	Port 6 data register	PDR6	R/W	Port 6	XXXXXXXX
07 <sub>H</sub>	Port 7 data register	PDR7	R/W	Port 7	XXXXXXXX
08 <sub>H</sub>	Port 8 data register	PDR8	R/W	Port 8	XXXXXXXX
09 <sub>H</sub>	Port 9 data register	PDR9	R/W	Port 9	XXXXXXXX
0A <sub>H</sub>	Port A data register	PDRA	R/W	Port A	XXXXXXXX
0B <sub>H</sub>	Analog Input Enable Port 5	ADER5	R/W	Port 5, A/D	11111111
0C <sub>H</sub>	Analog Input Enable Port 6	ADER6	R/W	Port 6, A/D	11111111
0D <sub>H</sub>	Analog Input Enable Port 7	ADER7	R/W	Port 7, A/D	11111111
0E <sub>H</sub>	Input level select register 0	ILSR0	R/W	Ports	XXXXXXXX
0F <sub>H</sub>	Input level select register 1	ILSR1	R/W	Ports	XXXXXXXX
10 <sub>H</sub>	Port 0 direction register	DDR0	R/W	Port 0	00000000
11 <sub>H</sub>	Port 1 direction register	DDR1	R/W	Port 1	00000000
12 <sub>H</sub>	Port 2 direction register	DDR2	R/W	Port 2	00000000
13 <sub>H</sub>	Port 3 direction register	DDR3	R/W	Port 3	00000000
14 <sub>H</sub>	Port 4 direction register	DDR4	R/W	Port 4	00000000
15 <sub>H</sub>	Port 5 direction register	DDR5	R/W	Port 5	00000000
16 <sub>H</sub>	Port 6 direction register	DDR6	R/W	Port 6	00000000
17 <sub>H</sub>	Port 7 direction register	DDR7	R/W	Port 7	00000000
18 <sub>H</sub>	Port 8 direction register	DDR8	R/W	Port 8	00000000
19 <sub>H</sub>	Port 9 direction register	DDR9	R/W	Port 9	00000000
1A <sub>H</sub>	Port A direction register	DDRA	R/W	Port A	00000100
1B <sub>H</sub>	Reserved				
1C <sub>H</sub>	Port 0 Pullup control register	PUCR0	R/W	Port 0	00000000
1D <sub>H</sub>	Port 1 Pullup control register	PUCR1	R/W	Port 1	00000000
1E <sub>H</sub>	Port 2 Pullup control register	PUCR2	R/W	Port 2	00000000
1F <sub>H</sub>	Port 3 Pullup control register	PUCR3	W, R/W	Port 3	00000000

(Continued)

# MB90340 Series

Address	Register	Abbrevia- tion	Access	Resource name	Initial value
20 <sub>H</sub>	Serial Mode Register	SMR0	W,R/W	UART0	00000000
21 <sub>H</sub>	Serial Control Register	SCR0	W,R/W		00000000
22 <sub>H</sub>	Reception/Transmission Data Register	RDR0/ TDR0	R/W		00000000
23 <sub>H</sub>	Serial Status Register	SSR0	R,R/W		00001000
24 <sub>H</sub>	Extended Communication Control Reg.	ECCR0	R,W,R/ W		000000XX
25 <sub>H</sub>	Extended Status/Control Register	ESCR0	R/W		00000100
26 <sub>H</sub>	Baud Rate Register 0	BGR00	R/W		00000000
27 <sub>H</sub>	Baud Rate Register 1	BGR01	R/W		00000000
28 <sub>H</sub>	Serial Mode Register	SMR1	W,R/W	UART1	00000000
29 <sub>H</sub>	Serial Control Register	SCR1	W,R/W		00000000
2A <sub>H</sub>	Reception/Transmission Data Register	RDR1/ TDR1	R/W		00000000
2B <sub>H</sub>	Serial Status Register	SSR1	R,R/W		00001000
2C <sub>H</sub>	Extended Communication Control Reg.	ECCR1	R,W, R/W		000000XX
2D <sub>H</sub>	Extended Status/Control Register	ESCR1	R/W		00000100
2E <sub>H</sub>	Baud Rate Register 0	BGR10	R/W		00000000
2F <sub>H</sub>	Baud Rate Register 1	BGR11	R/W		00000000
30 <sub>H</sub>	PPG 0 operation mode control register	PPGC0	W,R/W	16-bit Programmable Pulse Generator 0/1	0X000XX1
31 <sub>H</sub>	PPG 1 operation mode control register	PPGC1	W,R/W		0X000001
32 <sub>H</sub>	PPG 0 and PPG 1 clock select register	PPG01	R/W		000000X0
33 <sub>H</sub>	Reserved				
34 <sub>H</sub>	PPG 2 operation mode control register	PPGC2	W,R/W	16-bit Programmable Pulse Generator 2/3	0X000XX1
35 <sub>H</sub>	PPG 3 operation mode control register	PPGC3	W,R/W		0X000001
36 <sub>H</sub>	PPG 2 and PPG 3 clock select register	PPG23	R/W		000000X0
37 <sub>H</sub>	Reserved				
38 <sub>H</sub>	PPG 4 operation mode control register	PPGC4	W,R/W	16-bit Programmable Pulse Generator 4/5	0X000XX1
39 <sub>H</sub>	PPG 5 operation mode control register	PPGC5	W,R/W		0X000001
3A <sub>H</sub>	PPG 4 and PPG 5 clock select register	PPG45	R/W		000000X0
3B <sub>H</sub>	ROM Correction Control Status 1	PACSR1	R/W	ROM Correction 1	00000000
3C <sub>H</sub>	PPG 6 operation mode control register	PPGC6	W,R/W	16-bit Programmable Pulse Generator 6/7	0X000XX1
3D <sub>H</sub>	PPG 7 operation mode control register	PPGC7	W,R/W		0X000001
3E <sub>H</sub>	PPG 6 and PPG 7 clock select register	PPG67	R/W		000000X0
3F <sub>H</sub>	Reserved				

(Continued)

# MB90340 Series

Address	Register	Abbrevia- tion	Access	Resource name	Initial value
40H	PPG 8 operation mode control register	PPGC8	W,R/W	16-bit Programmable Pulse Generator 8/9	0X000XX1
41H	PPG 9 operation mode control register	PPGC9	W,R/W		0X000001
42H	PPG 8 and PPG 9 clock select register	PPG89	R/W		000000X0
43H	Reserved				
44H	PPG A operation mode control register	PPGCA	W,R/W	16-bit Programmable Pulse Generator A/B	0X000XX1
45H	PPG B operation mode control register	PPGCB	W,R/W		0X000001
46H	PPG A and PPG B clock select register	PPGAB	R/W		000000X0
47H	Reserved				
48H	PPG C operation mode control register	PPGCC	W,R/W	16-bit Programmable Pulse Generator C/D	0X000XX1
49H	PPG D operation mode control register	PPGCD	W,R/W		0X000001
4AH	PPG C and PPG D clock select register	PPGCD	R/W		000000X0
4BH	Reserved				
4CH	PPG E operation mode control register	PPGCE	W,R/W	16-bit Programmable Pulse Generator E/F	0X000XX1
4DH	PPG F operation mode control register	PPGCF	W,R/W		0X000001
4EH	PPG E and PPG F clock select register	PPGEF	R/W		000000X0
4FH	Reserved				
50H	Input Capture Control Status 0/1	ICS01	R/W	Input Capture 0/1	00000000
51H	Input Capture Edge 0/1	ICE01	R/W		XXX0X0XX
52H	Input Capture Control Status 2/3	ICS23	R/W	Input Capture 2/3	00000000
53H	Input Capture Edge 2/3	ICE23	R/W		XXXXXXXXXX
54H	Input Capture Control Status 4/5	ICS45	R/W	Input Capture 4/5	00000000
55H	Input Capture Edge 4/5	ICE45	R/W		XXXXXXXXXX
56H	Input Capture Control Status 6/7	ICS67	R/W	Input Capture 6/7	00000000
57H	Input Capture Edge 6/7	ICE67	R/W		XXX000XX
58H	Output Compare Control Status 0	OCS0	R/W	Output Compare 0/1	0000XX00
59H	Output Compare Control Status 1	OCS1	R/W		0XX00000
5AH	Output Compare Control Status 2	OCS2	R/W	Output Compare 2/3	0000XX00
5BH	Output Compare Control Status 3	OCS3	R/W		0XX00000
5CH	Output Compare Control Status 4	OCS4	R/W	Output Compare 4/5	0000XX00
5DH	Output Compare Control Status 5	OCS5	R/W		0XX00000
5EH	Output Compare Control Status 6	OCS6	R/W	Output Compare 6/7	0000XX00
5FH	Output Compare Control Status 7	OCS7	R/W		0XX00000

(Continued)



# MB90340 Series

Address	Register	Abbrevia- tion	Access	Resource name	Initial value
60H	Timer Control Status 0	TMCSR0	R/W	16-bit Reload Timer 0	00000000
61H	Timer Control Status 0	TMCSR0	R/W		XXXX0000
62H	Timer Control Status 1	TMCSR1	R/W	16-bit Reload Timer 1	00000000
63H	Timer Control Status 1	TMCSR1	R/W		XXXX0000
64H	Timer Control Status 2	TMCSR2	R/W	16-bit Reload Timer 2	00000000
65H	Timer Control Status 2	TMCSR2	R/W		XXXX0000
66H	Timer Control Status 3	TMCSR3	R/W	16-bit Reload Timer 3	00000000
67H	Timer Control Status 3	TMCSR3	R/W		XXXX0000
68H	A/D Control Status 0	ADCS0	R/W	A/D Converter	000XXXX0
69H	A/D Control Status 1	ADCS1	R/W		0000000X
6AH	A/D Data 0	ADCR0	R		00000000
6BH	A/D Data 1	ADCR1	R		XXXXXXXX00
6CH	ADC Setting 0	ADSR0	R/W		00000000
6DH	ADC Setting 1	ADSR1	R/W		00000000
6EH	Reserved				
6FH	ROM Mirror	ROMM	W	ROM Mirror	XXXXXXXX1
70H to 8FH	Reserved for CAN Interface 0/1. Refer to "■ CAN CONTROLLERS"				
90H to 9AH	Reserved				
9BH	DMA Descriptor Channel Select	DCSR	R/W	DMA	00000000
9CH	DMA Status L	DSRL	R/W		00000000
9DH	DMA Status H	DSRH	R/W		00000000
9EH	ROM Correction Control Status 0	PACSR0	R/W	ROM Correction 0	00000000
9FH	Delayed Interrupt/release	DIRR	R/W	Delayed Interrupt	XXXXXXXX0
A0H	Low-power Mode Control	LPMCR	W,R/W	Low Power Controller	00011000
A1H	Clock Selection	CKSCR	R,R/W	Low Power Controller	11111100
A2H, A3H	Reserved				
A4H	DMA Stop Status	DSSR	R/W	DMA	00000000
A5H	Automatic ready function select reg.	ARSR	W	External Memory Access	0011XX00
A6H	External address output control reg.	HACR	W		00000000
A7H	Bus control signal selection register	ECSR	W		0000000X
A8H	Watchdog Control	WDTC	R,W	Watchdog Timer	XXXXX111
A9H	Time Base Timer Control	TBTC	W,R/W	Time Base Timer	1XX00100

(Continued)

# MB90340 Series

Address	Register	Abbrevia- tion	Access	Resource name	Initial value
AA <sub>H</sub>	Watch Timer Control register	WTC	R,R/W	Watch Timer	1X001000
AB <sub>H</sub>	Reserved				
AC <sub>H</sub>	DMA Enable L	DERL	R/W	DMA	00000000
AD <sub>H</sub>	DMA Enable H	DERH	R/W		00000000
AE <sub>H</sub>	Flash Control Status (FlashDevices only. Otherwise reserved)	FMCS	R,R/W	Flash Memory	000X0000
AF <sub>H</sub>	Reserved				
B0 <sub>H</sub>	Interrupt control register 00	ICR00	W,R/W	Interrupt controller	00000111
B1 <sub>H</sub>	Interrupt control register 01	ICR01	W,R/W		00000111
B2 <sub>H</sub>	Interrupt control register 02	ICR02	W,R/W		00000111
B3 <sub>H</sub>	Interrupt control register 03	ICR03	W,R/W		00000111
B4 <sub>H</sub>	Interrupt control register 04	ICR04	W,R/W		00000111
B5 <sub>H</sub>	Interrupt control register 05	ICR05	W,R/W		00000111
B6 <sub>H</sub>	Interrupt control register 06	ICR06	W,R/W		00000111
B7 <sub>H</sub>	Interrupt control register 07	ICR07	W,R/W		00000111
B8 <sub>H</sub>	Interrupt control register 08	ICR08	W,R/W		00000111
B9 <sub>H</sub>	Interrupt control register 09	ICR09	W,R/W		00000111
BA <sub>H</sub>	Interrupt control register 10	ICR10	W,R/W		00000111
BB <sub>H</sub>	Interrupt control register 11	ICR11	W,R/W		00000111
BC <sub>H</sub>	Interrupt control register 12	ICR12	W,R/W		00000111
BD <sub>H</sub>	Interrupt control register 13	ICR13	W,R/W		00000111
BE <sub>H</sub>	Interrupt control register 14	ICR14	W,R/W		00000111
BF <sub>H</sub>	Interrupt control register 15	ICR15	W,R/W		00000111
C0 <sub>H</sub>	D/A Converter data 0	DAT0	R/W	D/A Converter	XXXXXXXX
C1 <sub>H</sub>	D/A Converter data 1	DAT1	R/W		XXXXXXXX
C2 <sub>H</sub>	D/A Control 0	DACR0	R/W		XXXXXXXX0
C3 <sub>H</sub>	D/A Control 1	DACR1	R/W		XXXXXXXX0
C4 <sub>H</sub> , C5 <sub>H</sub>	Reserved				
C6 <sub>H</sub>	External Interrupt Enable 0	ENIR0	R/W	External Interrupt 0	00000000
C7 <sub>H</sub>	External Interrupt Request 0	EIRR0	R/W		XXXXXXXX
C8 <sub>H</sub>	External Interrupt Level 0	ELVR0	R/W		00000000
C9 <sub>H</sub>	External Interrupt Level 0	ELVR0	R/W		00000000

(Continued)

# MB90340 Series

Address	Register	Abbrevia- tion	Access	Resource name	Initial value
CA <sub>H</sub>	External Interrupt Enable 1	ENIR1	R/W	External Interrupt 1	00000000
CB <sub>H</sub>	External Interrupt Request 1	EIRR1	R/W		XXXXXXXX
CC <sub>H</sub>	External Interrupt Level 1	ELVR1	R/W		00000000
CD <sub>H</sub>	External Interrupt Level 1	ELVR1	R/W		00000000
CE <sub>H</sub>	External Interrupt 1 Source Select	EISSR	R/W		00000000
CF <sub>H</sub>	PLL/Subclock Control register	PSCCR	W	PLL	XXXX0000
D0 <sub>H</sub>	DMA Buffer Addrss Pointer L	BAPL	R/W	DMA	XXXXXXXX
D1 <sub>H</sub>	DMA Buffer Addrss Pointer M	BAPM	R/W		XXXXXXXX
D2 <sub>H</sub>	DMA Buffer Addrss Pointer H	BAPH	R/W		XXXXXXXX
D3 <sub>H</sub>	DMA Control	DMACS	R/W		XXXXXXXX
D4 <sub>H</sub>	I/O Register Address Pointer L	IOAL	R/W		XXXXXXXX
D5 <sub>H</sub>	I/O Register Address Pointer H	IOAH	R/W		XXXXXXXX
D6 <sub>H</sub>	Data Counter L	DCTL	R/W		XXXXXXXX
D7 <sub>H</sub>	Data Counter H	DCTH	R/W		XXXXXXXX
D8 <sub>H</sub>	Serial Mode Register	SMR2	W,R/W	UART2	00000000
D9 <sub>H</sub>	Serial Control Register	SCR2	W,R/W		00000000
DA <sub>H</sub>	Reception/Transmission Data Register	RDR2/ TDR2	R/W		00000000
DB <sub>H</sub>	Serial Status Register	SSR2	R,R/W		00001000
DC <sub>H</sub>	Extended Communication Control Reg.	ECCR2	R,W, R/W		000000XX
DD <sub>H</sub>	Extended Status/Control Register	ESCR2	R/W		00000100
DE <sub>H</sub>	Baud Rate Register 0	BGR20	R/W		00000000
DF <sub>H</sub>	Baud Rate Register 1	BGR21	R/W		00000000
E0 <sub>H</sub> to EF <sub>H</sub>	Reserved for CAN Interface 2. Refer to "■ CAN CONTROLLERS"				
F0 <sub>H</sub> to FF <sub>H</sub>	External				

(Continued)

# MB90340 Series

Address	Register	Abbrevia- tion	Access	Resource name	Initial value
7900 <sub>H</sub>	Reload L	PRL0	R/W	16-bit Programmable Pulse Generator 0/1	XXXXXXXX
7901 <sub>H</sub>	Reload H	PRLH0	R/W		XXXXXXXX
7902 <sub>H</sub>	Reload L	PRL1	R/W		XXXXXXXX
7903 <sub>H</sub>	Reload H	PRLH1	R/W		XXXXXXXX
7904 <sub>H</sub>	Reload L	PRL2	R/W	16-bit Programmable Pulse Generator 2/3	XXXXXXXX
7905 <sub>H</sub>	Reload H	PRLH2	R/W		XXXXXXXX
7906 <sub>H</sub>	Reload L	PRL3	R/W		XXXXXXXX
7907 <sub>H</sub>	Reload H	PRLH3	R/W		XXXXXXXX
7908 <sub>H</sub>	Reload L	PRL4	R/W	16-bit Programmable Pulse Generator 4/5	XXXXXXXX
7909 <sub>H</sub>	Reload H	PRLH4	R/W		XXXXXXXX
790A <sub>H</sub>	Reload L	PRL5	R/W		XXXXXXXX
790B <sub>H</sub>	Reload H	PRLH5	R/W		XXXXXXXX
790C <sub>H</sub>	Reload L	PRL6	R/W	16-bit Programmable Pulse Generator 6/7	XXXXXXXX
790D <sub>H</sub>	Reload H	PRLH6	R/W		XXXXXXXX
790E <sub>H</sub>	Reload L	PRL7	R/W		XXXXXXXX
790F <sub>H</sub>	Reload H	PRLH7	R/W		XXXXXXXX
7910 <sub>H</sub>	Reload L	PRL8	R/W	16-bit Programmable Pulse Generator 8/9	XXXXXXXX
7911 <sub>H</sub>	Reload H	PRLH8	R/W		XXXXXXXX
7912 <sub>H</sub>	Reload L	PRL9	R/W		XXXXXXXX
7913 <sub>H</sub>	Reload H	PRLH9	R/W		XXXXXXXX
7914 <sub>H</sub>	Reload L	PRLA	R/W	16-bit Programmable Pulse Generator A/B	XXXXXXXX
7915 <sub>H</sub>	Reload H	PRLHA	R/W		XXXXXXXX
7916 <sub>H</sub>	Reload L	PRLB	R/W		XXXXXXXX
7917 <sub>H</sub>	Reload H	PRLHB	R/W		XXXXXXXX
7918 <sub>H</sub>	Reload L	PRLC	R/W	16-bit Programmable Pulse Generator C/D	XXXXXXXX
7919 <sub>H</sub>	Reload H	PRLHC	R/W		XXXXXXXX
791A <sub>H</sub>	Reload L	PRLD	R/W		XXXXXXXX
791B <sub>H</sub>	Reload H	PRLHD	R/W		XXXXXXXX
791C <sub>H</sub>	Reload L	PRLLE	R/W	16-bit Programmable Pulse Generator E/F	XXXXXXXX
791D <sub>H</sub>	Reload H	PRLHE	R/W		XXXXXXXX
791E <sub>H</sub>	Reload L	PRLLE	R/W		XXXXXXXX
791F <sub>H</sub>	Reload H	PRLHF	R/W		XXXXXXXX
7920 <sub>H</sub>	Input Capture 0	IPCP0	R	Input Capture 0/1	XXXXXXXX
7921 <sub>H</sub>	Input Capture 0	IPCP0	R		XXXXXXXX
7922 <sub>H</sub>	Input Capture 1	IPCP1	R		XXXXXXXX
7923 <sub>H</sub>	Input Capture 1	IPCP1	R		XXXXXXXX

(Continued)

# MB90340 Series

Address	Register	Abbreviation	Access	Resource name	Initial value
7924 <sub>H</sub>	Input Capture 2	IPCP2	R	Input Capture 2/3	XXXXXXXXXX
7925 <sub>H</sub>	Input Capture 2	IPCP2	R		XXXXXXXXXX
7926 <sub>H</sub>	Input Capture 3	IPCP3	R		XXXXXXXXXX
7927 <sub>H</sub>	Input Capture 3	IPCP3	R		XXXXXXXXXX
7928 <sub>H</sub>	Input Capture 4	IPCP4	R	Input Capture 4/5	XXXXXXXXXX
7929 <sub>H</sub>	Input Capture 4	IPCP4	R		XXXXXXXXXX
792A <sub>H</sub>	Input Capture 5	IPCP5	R		XXXXXXXXXX
792B <sub>H</sub>	Input Capture 5	IPCP5	R		XXXXXXXXXX
792C <sub>H</sub>	Input Capture 6	IPCP6	R	Input Capture 6/7	XXXXXXXXXX
792D <sub>H</sub>	Input Capture 6	IPCP6	R		XXXXXXXXXX
792E <sub>H</sub>	Input Capture 7	IPCP7	R		XXXXXXXXXX
792F <sub>H</sub>	Input Capture 7	IPCP7	R		XXXXXXXXXX
7930 <sub>H</sub>	Output Compare 0	OCCP0	R/W	Output Compare 0/1	XXXXXXXXXX
7931 <sub>H</sub>	Output Compare 0	OCCP0	R/W		XXXXXXXXXX
7932 <sub>H</sub>	Output Compare 1	OCCP1	R/W		XXXXXXXXXX
7933 <sub>H</sub>	Output Compare 1	OCCP1	R/W		XXXXXXXXXX
7934 <sub>H</sub>	Output Compare 2	OCCP2	R/W	Output Compare 2/3	XXXXXXXXXX
7935 <sub>H</sub>	Output Compare 2	OCCP2	R/W		XXXXXXXXXX
7936 <sub>H</sub>	Output Compare 3	OCCP3	R/W		XXXXXXXXXX
7937 <sub>H</sub>	Output Compare 3	OCCP3	R/W		XXXXXXXXXX
7938 <sub>H</sub>	Output Compare 4	OCCP4	R/W	Output Compare 4/5	XXXXXXXXXX
7939 <sub>H</sub>	Output Compare 4	OCCP4	R/W		XXXXXXXXXX
793A <sub>H</sub>	Output Compare 5	OCCP5	R/W		XXXXXXXXXX
793B <sub>H</sub>	Output Compare 5	OCCP5	R/W		XXXXXXXXXX
793C <sub>H</sub>	Output Compare 6	OCCP6	R/W	Output Compare 6/7	XXXXXXXXXX
793D <sub>H</sub>	Output Compare 6	OCCP6	R/W		XXXXXXXXXX
793E <sub>H</sub>	Output Compare 7	OCCP7	R/W		XXXXXXXXXX
793F <sub>H</sub>	Output Compare 7	OCCP7	R/W		XXXXXXXXXX
7940 <sub>H</sub>	Timer Data 0	TCDT0	R/W	I/O Timer 0	00000000
7941 <sub>H</sub>	Timer Data 0	TCDT0	R/W		00000000
7942 <sub>H</sub>	Timer Control 0	TCCSL0	R/W		00000000
7943 <sub>H</sub>	Timer Control 0	TCCSH0	R/W		0XXXXXXXXX
7944 <sub>H</sub>	Timer Data 1	TCDT1	R/W	I/O Timer 1	00000000
7945 <sub>H</sub>	Timer Data 1	TCDT1	R/W		00000000
7946 <sub>H</sub>	Timer Control 1	TCCSL1	R/W		00000000
7947 <sub>H</sub>	Timer Control 1	TCCSH1	R/W		0XXXXXXXXX

(Continued)

# MB90340 Series

Address	Register	Abbreviation	Access	Resource name	Initial value	
7948 <sub>H</sub>	Timer 0/Reload 0	TMR0/ TMRLR0	R/W	16-bit Reload Timer 0	XXXXXXXX	
7949 <sub>H</sub>			R/W		XXXXXXXX	
794A <sub>H</sub>	Timer 1/Reload 1	TMR1/ TMRLR1	R/W	16-bit Reload Timer 1	XXXXXXXX	
794B <sub>H</sub>			R/W		XXXXXXXX	
794C <sub>H</sub>	Timer 2/Reload 2	TMR2/ TMRLR2	R/W	16-bit Reload Timer 2	XXXXXXXX	
794D <sub>H</sub>			R/W		XXXXXXXX	
794E <sub>H</sub>	Timer 3/Reload 3	TMR3/ TMRLR3	R/W	16-bit Reload Timer 3	XXXXXXXX	
794F <sub>H</sub>			R/W		XXXXXXXX	
7950 <sub>H</sub>	Serial Mode Register	SMR3	W,R/W	UART3	00000000	
7951 <sub>H</sub>	Serial Control Register	SCR3	W,R/W		00000000	
7952 <sub>H</sub>	Reception/Transmission Data Register	RDR3/ TDR3	R/W		00000000	
7953 <sub>H</sub>	Serial Status Register	SSR3	R,R/W		00001000	
7954 <sub>H</sub>	Extended Communication Control Reg.	ECCR3	R,W, R/W		000000XX	
7955 <sub>H</sub>	Extended Status/Control Register	ESCR3	R/W		00000100	
7956 <sub>H</sub>	Baud Rate Register 0	BGR30	R/W		00000000	
7957 <sub>H</sub>	Baud Rate Register 1	BGR31	R/W		00000000	
7958 <sub>H</sub>	Serial Mode Register	SMR4	W,R/W		UART4	00000000
7959 <sub>H</sub>	Serial Control Register	SCR4	W,R/W			00000000
795A <sub>H</sub>	Reception/Transmission Data Register	RDR4/ TDR4	R/W	00000000		
795B <sub>H</sub>	Serial Status Register	SSR4	R,R/W	00001000		
795C <sub>H</sub>	Extended Communication Control Reg.	ECCR4	R,W, R/W	000000XX		
795D <sub>H</sub>	Extended Status/Control Register	ESCR4	R/W	00000100		
795E <sub>H</sub>	Baud Rate Register 0	BGR40	R/W	00000000		
795F <sub>H</sub>	Baud Rate Register 1	BGR41	R/W	00000000		
7960 <sub>H</sub> to 796B <sub>H</sub>	Reserved					
796C <sub>H</sub>	Clock output enable register	CLKR	R/W	Clock Monitor	XXXX0000	
796D <sub>H</sub>	Reserved					
796E <sub>H</sub>	CAN Direct Mode Register	CDMR	R/W	CAN clock sync	XXXXXXXX0	
796F <sub>H</sub>	CAN RX/TX redirect register	CANSWR	R/W	CAN 0/1	XXXXXXXX00	

(Continued)

# MB90340 Series

Address	Register	Abbrevia- tion	Access	Resource name	Initial value
7970 <sub>H</sub>	I <sup>2</sup> C bus status register	IBSR0	R	I <sup>2</sup> C Interface 0	00000000
7971 <sub>H</sub>	I <sup>2</sup> C bus control register	IBCR0	W,R/W		00000000
7972 <sub>H</sub>	I <sup>2</sup> C 10 bit slave address register	ITBAL0	R/W		00000000
7973 <sub>H</sub>		ITBAH0	R/W		00000000
7974 <sub>H</sub>	I <sup>2</sup> C 10 bit address mask register	ITMKL0	R/W		11111111
7975 <sub>H</sub>		ITMKH0	R/W		00111111
7976 <sub>H</sub>	I <sup>2</sup> C 7 bit slave address register	ISBA0	R/W		00000000
7977 <sub>H</sub>	I <sup>2</sup> C 7 bit address mask register	ISMK0	R/W		01111111
7978 <sub>H</sub>	I <sup>2</sup> C data register	IDAR0	R/W		00000000
7979 <sub>H</sub> , 797A <sub>H</sub>	Reserved				
797B <sub>H</sub>	I <sup>2</sup> C clock control register	ICCR0	R/W	I <sup>2</sup> C Interface 0	00011111
797C <sub>H</sub> to 797F <sub>H</sub>	Reserved				
7980 <sub>H</sub>	I <sup>2</sup> C bus status register	IBSR1	R	I <sup>2</sup> C Interface 1	00000000
7981 <sub>H</sub>	I <sup>2</sup> C bus control register	IBCR1	W,R/W		00000000
7982 <sub>H</sub>	I <sup>2</sup> C 10 bit slave address register	ITBAL1	R/W		00000000
7983 <sub>H</sub>		ITBAH1	R/W		00000000
7984 <sub>H</sub>	I <sup>2</sup> C 10 bit address mask register	ITMKL1	R/W		11111111
7985 <sub>H</sub>		ITMKH1	R/W		00111111
7986 <sub>H</sub>	I <sup>2</sup> C 7 bit slave address register	ISBA1	R/W		00000000
7987 <sub>H</sub>	I <sup>2</sup> C 7 bit address mask register	ISMK1	R/W		01111111
7988 <sub>H</sub>	I <sup>2</sup> C data register	IDAR1	R/W		00000000
7989 <sub>H</sub> , 798A <sub>H</sub>	Reserved				
798B <sub>H</sub>	I <sup>2</sup> C clock control register	ICCR1	R/W	I <sup>2</sup> C Interface 1	00011111
798C <sub>H</sub> to 79C1 <sub>H</sub>	Reserved				
79C2 <sub>H</sub>	Clock Modulator Control Register	CMCR	R,R/W	Clock Modulator	0001X000
79C3 <sub>H</sub> to 79DF <sub>H</sub>	Reserved				

(Continued)

# MB90340 Series

(Continued)

Address	Register	Abbrevia- tion	Access	Resource name	Initial value
79E0 <sub>H</sub>	ROM Correction Address 0	PADR0	R/W	ROM Correction 0	XXXXXXXX
79E1 <sub>H</sub>	ROM Correction Address 0	PADR0	R/W		XXXXXXXX
79E2 <sub>H</sub>	ROM Correction Address 0	PADR0	R/W		XXXXXXXX
79E3 <sub>H</sub>	ROM Correction Address 1	PADR1	R/W		XXXXXXXX
79E4 <sub>H</sub>	ROM Correction Address 1	PADR1	R/W		XXXXXXXX
79E5 <sub>H</sub>	ROM Correction Address 1	PADR1	R/W		XXXXXXXX
79E6 <sub>H</sub>	ROM Correction Address 2	PADR2	R/W		XXXXXXXX
79E7 <sub>H</sub>	ROM Correction Address 2	PADR2	R/W		XXXXXXXX
79E8 <sub>H</sub>	ROM Correction Address 2	PADR2	R/W		XXXXXXXX
79E9 <sub>H</sub> to 79EF <sub>H</sub>	Reserved				
79F0 <sub>H</sub>	ROM Correction Address 3	PADR3	R/W	ROM Correction 1	XXXXXXXX
79F1 <sub>H</sub>	ROM Correction Address 3	PADR3	R/W		XXXXXXXX
79F2 <sub>H</sub>	ROM Correction Address 3	PADR3	R/W		XXXXXXXX
79F3 <sub>H</sub>	ROM Correction Address 4	PADR4	R/W		XXXXXXXX
79F4 <sub>H</sub>	ROM Correction Address 4	PADR4	R/W		XXXXXXXX
79F5 <sub>H</sub>	ROM Correction Address 4	PADR4	R/W		XXXXXXXX
79F6 <sub>H</sub>	ROM Correction Address 5	PADR5	R/W		XXXXXXXX
79F7 <sub>H</sub>	ROM Correction Address 5	PADR5	R/W		XXXXXXXX
79F8 <sub>H</sub>	ROM Correction Address 5	PADR5	R/W		XXXXXXXX
79F9 <sub>H</sub> to 79FF <sub>H</sub>	Reserved				
7A00 <sub>H</sub> to 7AFF <sub>H</sub>	Reserved for CAN Interface 0. Refer to "■ CAN CONTROLLERS"				
7B00 <sub>H</sub> to 7BFF <sub>H</sub>	Reserved for CAN Interface 0. Refer to "■ CAN CONTROLLERS"				
7C00 <sub>H</sub> to 7CFF <sub>H</sub>	Reserved for CAN Interface 1. Refer to "■ CAN CONTROLLERS"				
7D00 <sub>H</sub> to 7DFF <sub>H</sub>	Reserved for CAN Interface 1. Refer to "■ CAN CONTROLLERS"				
7E00 <sub>H</sub> to 7EFF <sub>H</sub>	Reserved for CAN Interface 2. Refer to "■ CAN CONTROLLERS"				
7F00 <sub>H</sub> to 7FFF <sub>H</sub>	Reserved for CAN Interface 2. Refer to "■ CAN CONTROLLERS"				

Notes : • Initial value of "X" represents unknown value.

- Addresses in the range 0000<sub>H</sub> to 00BF<sub>H</sub>, which are not listed in the table, are reserved for the primary functions of the MCU. A read access to these reserved addresses results reading "X" and any write access should not be performed.



## ■ CAN CONTROLLERS

The CAN controller has the following features :

- Conforms to CAN Specification Version 2.0 Part A and B
  - Supports transmission/reception in standard frame and extended frame formats
- Supports transmitting of data frames by receiving remote frames
- 16 transmitting/receiving message buffers
  - 29-bit ID and 8-byte data
  - Multi-level message buffer configuration
- Provides full-bit comparison, full-bit mask, acceptance register 0/acceptance register 1 for each message buffer as ID acceptance mask
  - Two acceptance mask registers in either standard frame format or extended frame formats
- Bit rate programmable from 10 Kbits/s to 2 Mbits/s (when input clock is at 16 MHz)

**List of Control Registers (1)**

Address			Register	Abbreviation	Access	Initial Value
CAN0	CAN1	CAN2				
000070 <sub>H</sub>	000080 <sub>H</sub>	0000E0 <sub>H</sub>	Message buffer valid register	BVALR	R/W	00000000 00000000
000071 <sub>H</sub>	000081 <sub>H</sub>	0000E1 <sub>H</sub>				
000072 <sub>H</sub>	000082 <sub>H</sub>	0000E2 <sub>H</sub>	Transmit request register	TREQR	R/W	00000000 00000000
000073 <sub>H</sub>	000083 <sub>H</sub>	0000E3 <sub>H</sub>				
000074 <sub>H</sub>	000084 <sub>H</sub>	0000E4 <sub>H</sub>	Transmit cancel register	TCANR	W	00000000 00000000
000075 <sub>H</sub>	000085 <sub>H</sub>	0000E5 <sub>H</sub>				
000076 <sub>H</sub>	000086 <sub>H</sub>	0000E6 <sub>H</sub>	Transmission complete register	TCR	R/W	00000000 00000000
000077 <sub>H</sub>	000087 <sub>H</sub>	0000E7 <sub>H</sub>				
000078 <sub>H</sub>	000088 <sub>H</sub>	0000E8 <sub>H</sub>	Receive complete register	RCR	R/W	00000000 00000000
000079 <sub>H</sub>	000089 <sub>H</sub>	0000E9 <sub>H</sub>				
00007A <sub>H</sub>	00008A <sub>H</sub>	0000EA <sub>H</sub>	Remote request receiving register	RRTRR	R/W	00000000 00000000
00007B <sub>H</sub>	00008B <sub>H</sub>	0000EB <sub>H</sub>				
00007C <sub>H</sub>	00008C <sub>H</sub>	0000EC <sub>H</sub>	Receive overrun register	ROVRR	R/W	00000000 00000000
00007D <sub>H</sub>	00008D <sub>H</sub>	0000ED <sub>H</sub>				
00007E <sub>H</sub>	00008E <sub>H</sub>	0000EE <sub>H</sub>	Reception interrupt enable register	RIER	R/W	00000000 00000000
00007F <sub>H</sub>	00008F <sub>H</sub>	0000EF <sub>H</sub>				

# MB90340 Series

List of Control Registers (2)

Address			Register	Abbreviation	Access	Initial Value
CAN0	CAN1	CAN2				
007B00H	007D00H	007F00H	Control status register	CSR	R/W, W R/W, R	0XXXX0X1 00XXX000
007B01H	007D01H	007F01H				
007B02H	007D02H	007F02H	Last event indicator register	LEIR	R/W	000X0000 XXXXXXXX
007B03H	007D03H	007F03H				
007B04H	007D04H	007F04H	Receive/transmit error counter	RTEC	R	00000000 00000000
007B05H	007D05H	007F05H				
007B06H	007D06H	007F06H	Bit timing register	BTR	R/W	11111111 X1111111
007B07H	007D07H	007F07H				
007B08H	007D08H	007F08H	IDE register	IDER	R/W	XXXXXXXX XXXXXXXX
007B09H	007D09H	007F09H				
007B0AH	007D0AH	007F0AH	Transmit RTR register	TRTRR	R/W	00000000 00000000
007B0BH	007D0BH	007F0BH				
007B0CH	007D0CH	007F0CH	Remote frame receive waiting register	RFWTR	R/W	XXXXXXXX XXXXXXXX
007B0DH	007D0DH	007F0DH				
007B0EH	007D0EH	007F0EH	Transmit interrupt enable register	TIER	R/W	00000000 00000000
007B0FH	007D0FH	007F0FH				
007B10H	007D10H	007F10H	Acceptance mask select register	AMSR	R/W	XXXXXXXX XXXXXXXX
007B11H	007D11H	007F11H				
007B12H	007D12H	007F12H				
007B13H	007D13H	007F13H				
007B14H	007D14H	007F14H	Acceptance mask register 0	AMR0	R/W	XXXXXXXX XXXXXXXX
007B15H	007D15H	007F15H				
007B16H	007D16H	007F16H				
007B17H	007D17H	007F17H				
007B18H	007D18H	007F18H	Acceptance mask register 1	AMR1	R/W	XXXXXXXX XXXXXXXX
007B19H	007D19H	007F19H				
007B1AH	007D1AH	007F1AH				
007B1BH	007D1BH	007F1BH				

List of Message Buffers (ID Registers) (1)

Address			Register	Abbreviation	Access	Initial Value
CAN0	CAN1	CAN2				
007A00H to 007A1FH	007C00H to 007C1FH	007E00H to 007E1FH	General- purpose RAM	—	R/W	XXXXXXXXX to XXXXXXXXX
007A20H	007C20H	007E20H	ID register 0	IDR0	R/W	XXXXXXXXX XXXXXXXXX
007A21H	007C21H	007E21H				
007A22H	007C22H	007E22H				
007A23H	007C23H	007E23H				XXXXXXXXX XXXXXXXXX
007A24H	007C24H	007E24H	ID register 1	IDR1	R/W	XXXXXXXXX XXXXXXXXX
007A25H	007C25H	007E25H				
007A26H	007C26H	007E26H				
007A27H	007C27H	007E27H				XXXXXXXXX XXXXXXXXX
007A28H	007C28H	007E28H	ID register 2	IDR2	R/W	XXXXXXXXX XXXXXXXXX
007A29H	007C29H	007E29H				
007A2AH	007C2AH	007E2AH				
007A2BH	007C2BH	007E2BH				XXXXXXXXX XXXXXXXXX
007A2CH	007C2CH	007E2CH	ID register 3	IDR3	R/W	XXXXXXXXX XXXXXXXXX
007A2DH	007C2DH	007E2DH				
007A2EH	007C2EH	007E2EH				
007A2FH	007C2FH	007E2FH				XXXXXXXXX XXXXXXXXX
007A30H	007C30H	007E30H	ID register 4	IDR4	R/W	XXXXXXXXX XXXXXXXXX
007A31H	007C31H	007E31H				
007A32H	007C32H	007E32H				
007A33H	007C33H	007E33H				XXXXXXXXX XXXXXXXXX
007A34H	007C34H	007E34H	ID register 5	IDR5	R/W	XXXXXXXXX XXXXXXXXX
007A35H	007C35H	007E35H				
007A36H	007C36H	007E36H				
007A37H	007C37H	007E37H				XXXXXXXXX XXXXXXXXX
007A38H	007C38H	007E38H	ID register 6	IDR6	R/W	XXXXXXXXX XXXXXXXXX
007A39H	007C39H	007E39H				
007A3AH	007C3AH	007E3AH				
007A3BH	007C3BH	007E3BH				XXXXXXXXX XXXXXXXXX
007A3CH	007C3CH	007E3CH	ID register 7	IDR7	R/W	XXXXXXXXX XXXXXXXXX
007A3DH	007C3DH	007E3DH				
007A3EH	007C3EH	007E3EH				
007A3FH	007C3FH	007E3FH				XXXXXXXXX XXXXXXXXX

# MB90340 Series

List of Message Buffers (ID Registers) (2)

Address			Register	Abbreviation	Access	Initial Value
CAN0	CAN1	CAN2				
007A40 <sub>H</sub>	007C40 <sub>H</sub>	007E40 <sub>H</sub>	ID register 8	IDR8	R/W	XXXXXXXX XXXXXXXX
007A41 <sub>H</sub>	007C41 <sub>H</sub>	007E41 <sub>H</sub>				
007A42 <sub>H</sub>	007C42 <sub>H</sub>	007E42 <sub>H</sub>				
007A43 <sub>H</sub>	007C43 <sub>H</sub>	007E43 <sub>H</sub>				XXXXXXXX XXXXXXXX
007A44 <sub>H</sub>	007C44 <sub>H</sub>	007E44 <sub>H</sub>	ID register 9	IDR9	R/W	XXXXXXXX XXXXXXXX
007A45 <sub>H</sub>	007C45 <sub>H</sub>	007E45 <sub>H</sub>				
007A46 <sub>H</sub>	007C46 <sub>H</sub>	007E46 <sub>H</sub>				
007A47 <sub>H</sub>	007C47 <sub>H</sub>	007E47 <sub>H</sub>				XXXXXXXX XXXXXXXX
007A48 <sub>H</sub>	007C48 <sub>H</sub>	007E48 <sub>H</sub>	ID register 10	IDR10	R/W	XXXXXXXX XXXXXXXX
007A49 <sub>H</sub>	007C49 <sub>H</sub>	007E49 <sub>H</sub>				
007A4A <sub>H</sub>	007C4A <sub>H</sub>	007E4A <sub>H</sub>				
007A4B <sub>H</sub>	007C4B <sub>H</sub>	007E4B <sub>H</sub>				XXXXXXXX XXXXXXXX
007A4C <sub>H</sub>	007C4C <sub>H</sub>	007E4C <sub>H</sub>	ID register 11	IDR11	R/W	XXXXXXXX XXXXXXXX
007A4D <sub>H</sub>	007C4D <sub>H</sub>	007E4D <sub>H</sub>				
007A4E <sub>H</sub>	007C4E <sub>H</sub>	007E4E <sub>H</sub>				
007A4F <sub>H</sub>	007C4F <sub>H</sub>	007E4F <sub>H</sub>				XXXXXXXX XXXXXXXX
007A50 <sub>H</sub>	007C50 <sub>H</sub>	007E50 <sub>H</sub>	ID register 12	IDR12	R/W	XXXXXXXX XXXXXXXX
007A51 <sub>H</sub>	007C51 <sub>H</sub>	007E51 <sub>H</sub>				
007A52 <sub>H</sub>	007C52 <sub>H</sub>	007E52 <sub>H</sub>				
007A53 <sub>H</sub>	007C53 <sub>H</sub>	007E53 <sub>H</sub>				XXXXXXXX XXXXXXXX
007A54 <sub>H</sub>	007C54 <sub>H</sub>	007E54 <sub>H</sub>	ID register 13	IDR13	R/W	XXXXXXXX XXXXXXXX
007A55 <sub>H</sub>	007C55 <sub>H</sub>	007E55 <sub>H</sub>				
007A56 <sub>H</sub>	007C56 <sub>H</sub>	007E56 <sub>H</sub>				
007A57 <sub>H</sub>	007C57 <sub>H</sub>	007E57 <sub>H</sub>				XXXXXXXX XXXXXXXX
007A58 <sub>H</sub>	007C58 <sub>H</sub>	007E58 <sub>H</sub>	ID register 14	IDR14	R/W	XXXXXXXX XXXXXXXX
007A59 <sub>H</sub>	007C59 <sub>H</sub>	007E59 <sub>H</sub>				
007A5A <sub>H</sub>	007C5A <sub>H</sub>	007E5A <sub>H</sub>				
007A5B <sub>H</sub>	007C5B <sub>H</sub>	007E5B <sub>H</sub>				XXXXXXXX XXXXXXXX
007A5C <sub>H</sub>	007C5C <sub>H</sub>	007E5C <sub>H</sub>	ID register 15	IDR15	R/W	XXXXXXXX XXXXXXXX
007A5D <sub>H</sub>	007C5D <sub>H</sub>	007E5D <sub>H</sub>				
007A5E <sub>H</sub>	007C5E <sub>H</sub>	007E5E <sub>H</sub>				
007A5F <sub>H</sub>	007C5F <sub>H</sub>	007E5F <sub>H</sub>				XXXXXXXX XXXXXXXX

List of Message Buffers (DLC Registers and Data Registers) (1)

Address			Register	Abbreviation	Access	Initial Value
CAN0	CAN1	CAN2				
007A60 <sub>H</sub>	007C60 <sub>H</sub>	007E60 <sub>H</sub>	DLC register 0	DLCR0	R/W	XXXXXXXX
007A61 <sub>H</sub>	007C61 <sub>H</sub>	007E61 <sub>H</sub>				
007A62 <sub>H</sub>	007C62 <sub>H</sub>	007E62 <sub>H</sub>	DLC register 1	DLCR1	R/W	XXXXXXXX
007A63 <sub>H</sub>	007C63 <sub>H</sub>	007E63 <sub>H</sub>				
007A64 <sub>H</sub>	007C64 <sub>H</sub>	007E64 <sub>H</sub>	DLC register 2	DLCR2	R/W	XXXXXXXX
007A65 <sub>H</sub>	007C65 <sub>H</sub>	007E65 <sub>H</sub>				
007A66 <sub>H</sub>	007C66 <sub>H</sub>	007E66 <sub>H</sub>	DLC register 3	DLCR3	R/W	XXXXXXXX
007A67 <sub>H</sub>	007C67 <sub>H</sub>	007E67 <sub>H</sub>				
007A68 <sub>H</sub>	007C68 <sub>H</sub>	007E68 <sub>H</sub>	DLC register 4	DLCR4	R/W	XXXXXXXX
007A69 <sub>H</sub>	007C69 <sub>H</sub>	007E69 <sub>H</sub>				
007A6A <sub>H</sub>	007C6A <sub>H</sub>	007E6A <sub>H</sub>	DLC register 5	DLCR5	R/W	XXXXXXXX
007A6B <sub>H</sub>	007C6B <sub>H</sub>	007E6B <sub>H</sub>				
007A6C <sub>H</sub>	007C6C <sub>H</sub>	007E6C <sub>H</sub>	DLC register 6	DLCR6	R/W	XXXXXXXX
007A6D <sub>H</sub>	007C6D <sub>H</sub>	007E6D <sub>H</sub>				
007A6E <sub>H</sub>	007C6E <sub>H</sub>	007E6E <sub>H</sub>	DLC register 7	DLCR7	R/W	XXXXXXXX
007A6F <sub>H</sub>	007C6F <sub>H</sub>	007E6F <sub>H</sub>				
007A70 <sub>H</sub>	007C70 <sub>H</sub>	007E70 <sub>H</sub>	DLC register 8	DLCR8	R/W	XXXXXXXX
007A71 <sub>H</sub>	007C71 <sub>H</sub>	007E71 <sub>H</sub>				
007A72 <sub>H</sub>	007C72 <sub>H</sub>	007E72 <sub>H</sub>	DLC register 9	DLCR9	R/W	XXXXXXXX
007A73 <sub>H</sub>	007C73 <sub>H</sub>	007E73 <sub>H</sub>				
007A74 <sub>H</sub>	007C74 <sub>H</sub>	007E74 <sub>H</sub>	DLC register 10	DLCR10	R/W	XXXXXXXX
007A75 <sub>H</sub>	007C75 <sub>H</sub>	007E75 <sub>H</sub>				
007A76 <sub>H</sub>	007C76 <sub>H</sub>	007E76 <sub>H</sub>	DLC register 11	DLCR11	R/W	XXXXXXXX
007A77 <sub>H</sub>	007C77 <sub>H</sub>	007E77 <sub>H</sub>				
007A78 <sub>H</sub>	007C78 <sub>H</sub>	007E78 <sub>H</sub>	DLC register 12	DLCR12	R/W	XXXXXXXX
007A79 <sub>H</sub>	007C79 <sub>H</sub>	007E79 <sub>H</sub>				
007A7A <sub>H</sub>	007C7A <sub>H</sub>	007E7A <sub>H</sub>	DLC register 13	DLCR13	R/W	XXXXXXXX
007A7B <sub>H</sub>	007C7B <sub>H</sub>	007E7B <sub>H</sub>				
007A7C <sub>H</sub>	007C7C <sub>H</sub>	007E7C <sub>H</sub>	DLC register 14	DLCR14	R/W	XXXXXXXX
007A7D <sub>H</sub>	007C7D <sub>H</sub>	007E7D <sub>H</sub>				
007A7E <sub>H</sub>	007C7E <sub>H</sub>	007E7E <sub>H</sub>	DLC register 15	DLCR15	R/W	XXXXXXXX
007A7F <sub>H</sub>	007C7F <sub>H</sub>	007E7F <sub>H</sub>				

# MB90340 Series

List of Message Buffers (DLC Registers and Data Registers) (2)

Address			Register	Abbreviation	Access	Initial Value
CAN0	CAN1	CAN2				
007A80 <sub>H</sub> to 007A87 <sub>H</sub>	007C80 <sub>H</sub> to 007C87 <sub>H</sub>	007E80 <sub>H</sub> to 007E87 <sub>H</sub>	Data register 0 (8 bytes)	DTR0	R/W	XXXXXXXX to XXXXXXXX
007A88 <sub>H</sub> to 007A8F <sub>H</sub>	007C88 <sub>H</sub> to 007C8F <sub>H</sub>	007E88 <sub>H</sub> to 007E8F <sub>H</sub>	Data register 1 (8 bytes)	DTR1	R/W	XXXXXXXX to XXXXXXXX
007A90 <sub>H</sub> to 007A97 <sub>H</sub>	007C90 <sub>H</sub> to 007C97 <sub>H</sub>	007E90 <sub>H</sub> to 007E97 <sub>H</sub>	Data register 2 (8 bytes)	DTR2	R/W	XXXXXXXX to XXXXXXXX
007A98 <sub>H</sub> to 007A9F <sub>H</sub>	007C98 <sub>H</sub> to 007C9F <sub>H</sub>	007E98 <sub>H</sub> to 007E9F <sub>H</sub>	Data register 3 (8 bytes)	DTR3	R/W	XXXXXXXX to XXXXXXXX
007AA0 <sub>H</sub> to 007AA7 <sub>H</sub>	007CA0 <sub>H</sub> to 007CA7 <sub>H</sub>	007EA0 <sub>H</sub> to 007EA7 <sub>H</sub>	Data register 4 (8 bytes)	DTR4	R/W	XXXXXXXX to XXXXXXXX
007AA8 <sub>H</sub> to 007AAF <sub>H</sub>	007CA8 <sub>H</sub> to 007CAF <sub>H</sub>	007EA8 <sub>H</sub> to 007EAF <sub>H</sub>	Data register 5 (8 bytes)	DTR5	R/W	XXXXXXXX to XXXXXXXX
007AB0 <sub>H</sub> to 007AB7 <sub>H</sub>	007CB0 <sub>H</sub> to 007CB7 <sub>H</sub>	007EB0 <sub>H</sub> to 007EB7 <sub>H</sub>	Data register 6 (8 bytes)	DTR6	R/W	XXXXXXXX to XXXXXXXX
007AB8 <sub>H</sub> to 007ABF <sub>H</sub>	007CB8 <sub>H</sub> to 007CBF <sub>H</sub>	007EB8 <sub>H</sub> to 007EBF <sub>H</sub>	Data register 7 (8 bytes)	DTR7	R/W	XXXXXXXX to XXXXXXXX
007AC0 <sub>H</sub> to 007AC7 <sub>H</sub>	007CC0 <sub>H</sub> to 007CC7 <sub>H</sub>	007EC0 <sub>H</sub> to 007EC7 <sub>H</sub>	Data register 8 (8 bytes)	DTR8	R/W	XXXXXXXX to XXXXXXXX
007AC8 <sub>H</sub> to 007ACF <sub>H</sub>	007CC8 <sub>H</sub> to 007CCF <sub>H</sub>	007EC8 <sub>H</sub> to 007ECF <sub>H</sub>	Data register 9 (8 bytes)	DTR9	R/W	XXXXXXXX to XXXXXXXX
007AD0 <sub>H</sub> to 007AD7 <sub>H</sub>	007CD0 <sub>H</sub> to 007CD7 <sub>H</sub>	007ED0 <sub>H</sub> to 007ED7 <sub>H</sub>	Data register 10 (8 bytes)	DTR10	R/W	XXXXXXXX to XXXXXXXX
007AD8 <sub>H</sub> to 007ADF <sub>H</sub>	007CD8 <sub>H</sub> to 007CDF <sub>H</sub>	007ED8 <sub>H</sub> to 007EDF <sub>H</sub>	Data register 11 (8 bytes)	DTR11	R/W	XXXXXXXX to XXXXXXXX
007AE0 <sub>H</sub> to 007AE7 <sub>H</sub>	007CE0 <sub>H</sub> to 007CE7 <sub>H</sub>	007EE0 <sub>H</sub> to 007EE7 <sub>H</sub>	Data register 12 (8 bytes)	DTR12	R/W	XXXXXXXX to XXXXXXXX
007AE8 <sub>H</sub> to 007AEF <sub>H</sub>	007CE8 <sub>H</sub> to 007CEF <sub>H</sub>	007EE8 <sub>H</sub> to 007EEF <sub>H</sub>	Data register 13 (8 bytes)	DTR13	R/W	XXXXXXXX to XXXXXXXX

# MB90340 Series

List of Message Buffers (DLC Registers and Data Registers) (3)

Address			Register	Abbreviation	Access	Initial Value
CAN0	CAN1	CAN2				
007AF0 <sub>H</sub> to 007AF7 <sub>H</sub>	007CF0 <sub>H</sub> to 007CF7 <sub>H</sub>	007EF0 <sub>H</sub> to 007EF7 <sub>H</sub>	Data register 14 (8 bytes)	DTR14	R/W	XXXXXXXX to XXXXXXXX
007AF8 <sub>H</sub> to 007AFF <sub>H</sub>	007CF8 <sub>H</sub> to 007CFF <sub>H</sub>	007EF8 <sub>H</sub> to 007EFF <sub>H</sub>	Data register 15 (8 bytes)	DTR15	R/W	XXXXXXXX to XXXXXXXX

# MB90340 Series

## ■ INTERRUPT FACTORS, INTERRUPT VECTORS, INTERRUPT CONTROL REGISTER

Interrupt cause	EI <sup>2</sup> OS clear	DMA ch number	Interrupt vector		Interrupt control register	
			Number	Address	Number	Address
Reset	N	—	#08	FFFFDC <sub>H</sub>	—	—
INT9 instruction	N	—	#09	FFFFD8 <sub>H</sub>	—	—
Exception	N	—	#10	FFFFD4 <sub>H</sub>	—	—
CAN 0 RX	N	—	#11	FFFFD0 <sub>H</sub>	ICR00	0000B0 <sub>H</sub>
CAN 0 TX/NS	N	—	#12	FFFFCC <sub>H</sub>		
CAN 1 RX / Input Capture 6	Y1	—	#13	FFFFC8 <sub>H</sub>	ICR01	0000B1 <sub>H</sub>
CAN 1 TX/NS / Input Capture 7	Y1	—	#14	FFFFC4 <sub>H</sub>		
CAN 2 RX / I <sup>2</sup> C0	N	—	#15	FFFFC0 <sub>H</sub>	ICR02	0000B2 <sub>H</sub>
CAN 2 TX/NS	N	—	#16	FFFFBC <sub>H</sub>		
16-bit Reload Timer 0	Y1	0	#17	FFFFB8 <sub>H</sub>	ICR03	0000B3 <sub>H</sub>
16-bit Reload Timer 1	Y1	1	#18	FFFFB4 <sub>H</sub>		
16-bit Reload Timer 2	Y1	2	#19	FFFFB0 <sub>H</sub>	ICR04	0000B4 <sub>H</sub>
16-bit Reload Timer 3	Y1	—	#20	FFFFAC <sub>H</sub>		
PPG 0/1/4/5	N	—	#21	FFFFA8 <sub>H</sub>	ICR05	0000B5 <sub>H</sub>
PPG 2/3/6/7	N	—	#22	FFFFA4 <sub>H</sub>		
PPG 8/9/C/D	N	—	#23	FFFFA0 <sub>H</sub>	ICR06	0000B6 <sub>H</sub>
PPG A/B/E/F	N	—	#24	FFFF9C <sub>H</sub>		
Time Base Timer	N	—	#25	FFFF98 <sub>H</sub>	ICR07	0000B7 <sub>H</sub>
External Interrupt 0 to 3, 8 to 11	Y1	3	#26	FFFF94 <sub>H</sub>		
Watch Timer	N	—	#27	FFFF90 <sub>H</sub>	ICR08	0000B8 <sub>H</sub>
External Interrupt 4 to 7, 12 to 15	Y1	4	#28	FFFF8C <sub>H</sub>		
A/D Converter	Y1	5	#29	FFFF88 <sub>H</sub>	ICR09	0000B9 <sub>H</sub>
I/O Timer 0 / I/O Timer 1	N	—	#30	FFFF84 <sub>H</sub>		
Input Capture 4/5 / I <sup>2</sup> C1	Y1	6	#31	FFFF80 <sub>H</sub>	ICR10	0000BA <sub>H</sub>
Output Compare 0/1/4/5	Y1	7	#32	FFFF7C <sub>H</sub>		
Input Capture 0 to 3	Y1	8	#33	FFFF78 <sub>H</sub>	ICR11	0000BB <sub>H</sub>
Output Compare 2/3/6/7	Y1	9	#34	FFFF74 <sub>H</sub>		
UART 0 RX	Y2	10	#35	FFFF70 <sub>H</sub>	ICR12	0000BC <sub>H</sub>
UART 0 TX	Y1	11	#36	FFFF6C <sub>H</sub>		
UART 1 RX / UART 3 RX	Y2	12	#37	FFFF68 <sub>H</sub>	ICR13	0000BD <sub>H</sub>
UART 1 TX / UART 3 TX	Y1	13	#38	FFFF64 <sub>H</sub>		

(Continued)



(Continued)

Interrupt cause	EI <sup>2</sup> OS clear	DMA ch number	Interrupt vector		Interrupt control register	
			Number	Address	Number	Address
UART 2 RX / UART 4 RX	Y2	14	#39	FFFF60H	ICR14	0000BEH
UART 2 TX / UART 4 TX	Y1	15	#40	FFFF5CH		
Flash Memory	N	—	#41	FFFF58H	ICR15	0000BFH
Delayed interrupt	N	—	#42	FFFF54H		

Y1 : Usable

Y2 : Usable, with EI<sup>2</sup>OS stop function

N : Unusable

- Notes :
- The peripheral resources sharing the ICR register have the same interrupt level.
  - When two peripheral resources share the ICR register, only one can use Extended Intelligent I/O Service at a time.
  - When either of the two peripheral resources sharing the ICR register specifies Extended Intelligent I/O Service, the other one cannot use interrupts.

# MB90340 Series

## ■ ELECTRICAL CHARACTERISTICS

### 1. Absolute Maximum Ratings

( $V_{SS} = AV_{SS} = 0\text{ V}$ )

Parameter	Symbol	Rating		Unit	Remarks
		Min	Max		
Power supply voltage	$V_{CC}$	$V_{SS} - 0.3$	$V_{SS} + 6.0$	V	
	$AV_{CC}$	$V_{SS} - 0.3$	$V_{SS} + 6.0$	V	$V_{CC} = AV_{CC} \times 1$
	$AV_{RH}$ , $AV_{RL}$	$V_{SS} - 0.3$	$V_{SS} + 6.0$	V	$AV_{CC} \geq AV_{RH}$ , $AV_{CC} \geq AV_{RL}$ , $AV_{RH} \geq AV_{RL}$
Input voltage	$V_I$	$V_{SS} - 0.3$	$V_{SS} + 6.0$	V	*2
Output voltage	$V_O$	$V_{SS} - 0.3$	$V_{SS} + 6.0$	V	*2
Maximum Clamp Current	$I_{CLAMP}$	-4.0	+4.0	mA	*4
Total Maximum Clamp Current	$\Sigma I_{CLAMP} $	—	40	mA	*4
"L" level maximum output current	$I_{OL}$	—	15	mA	*3
"L" level average output current	$I_{OLAV}$	—	4	mA	*3
"L" level maximum overall output current	$\Sigma I_{OL}$	—	100	mA	*3
"L" level average overall output current	$\Sigma I_{OLAV}$	—	50	mA	*3
"H" level maximum output current	$I_{OH}$	—	-15	mA	*3
"H" level average output current	$I_{OHAV}$	—	-4	mA	*3
"H" level maximum overall output current	$\Sigma I_{OH}$	—	-100	mA	*3
"H" level average overall output current	$\Sigma I_{OHAV}$	—	-50	mA	*3
Power consumption	$P_D$	—	340	mW	MB90F347
Operating temperature	$T_A$	-40	+105	°C	
Storage temperature	$T_{STG}$	-55	+150	°C	

(Continued)

(Continued)

- \*1: Set  $AV_{CC}$  and  $V_{CC}$  to the same voltage. Make sure that  $AV_{CC}$  does not exceed  $V_{CC}$  and that the voltage at the analog inputs does not exceed  $AV_{CC}$  when the power is switched on.
- \*2:  $V_I$  and  $V_O$  should not exceed  $V_{CC} + 0.3$  V.  $V_I$  should not exceed the specified ratings. However if the maximum current to/from an input is limited by some means with external components, the  $I_{CLAMP}$  rating supercedes the  $V_I$  rating.
- \*3: Applicable to pins: P00 to P07, P10 to P17, P20 to P27, P30 to P37, P40 to P47, P50 to P57, P60 to P67, P70 to P77, P80 to P87, P90 to P97, PA0 to PA1
- \*4:
  - Applicable to pins: P00 to P07, P10 to P17, P20 to P27, P30 to P37, P40 to P47, P50 to P57, P60 to P67, P70 to P77, P80 to P87, P90 to P97, PA0 to PA1
  - Use within recommended operating conditions.
  - Use at DC voltage (current)
  - The +B signal should always be applied a limiting resistance placed between the +B signal and the microcontroller.
  - The value of the limiting resistance should be set so that when the +B signal is applied the input current to the microcontroller pin does not exceed rated values, either instantaneously or for prolonged periods.
  - Note that when the microcontroller drive current is low, such as in the power saving modes, the +B input potential may pass through the protective diode and increase the potential at the  $V_{CC}$  pin, and this may affect other devices.
  - Note that if a +B signal is input when the microcontroller power supply is off (not fixed at 0 V) , the power supply is provided from the pins, so that incomplete operation may result.
  - Note that if the +B input is applied during power-on, the power supply is provided from the pins and the resulting supply voltage may not be sufficient to operate the power-on reset.
  - Care must be taken not to leave the +B input pin open.
  - Sample recommended circuits:

• Input/output equivalent circuits

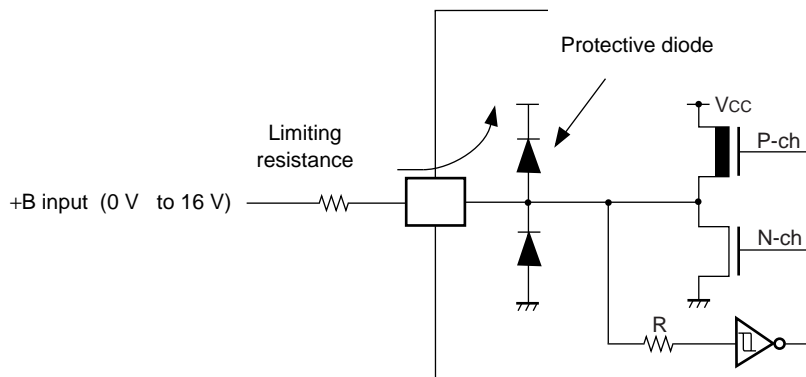

**WARNING:** Semiconductor devices can be permanently damaged by application of stress (voltage, current, temperature, etc.) in excess of absolute maximum ratings. Do not exceed these ratings.

# MB90340 Series

## 2. Recommended Conditions

( $V_{SS} = AV_{SS} = 0\text{ V}$ )

Parameter	Symbol	Value			Unit	Remarks
		Min	Typ	Max		
Power supply voltage	$V_{CC}, AV_{CC}$	4.0	5.0	5.5	V	Under normal operation
		3.5	5.0	5.5	V	Under normal operation, when not using the A/D converter and not Flash programming.
		4.5	5.0	5.5	V	When External bus is used.
		3.0	—	5.5	V	Maintains RAM data in stop mode
Smooth capacitor	$C_s$	0.1	—	1.0	$\mu\text{F}$	Use a ceramic capacitor or capacitor of better AC characteristics. Capacitor at the $V_{CC}$ should be greater than this capacitor.
Operating temperature	$T_A$	-40	—	+105	$^{\circ}\text{C}$	

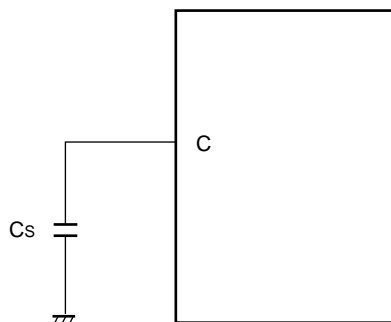

**C Pin Connection Diagram**

**WARNING:** The recommended operating conditions are required in order to ensure the normal operation of the semiconductor device. All of the device's electrical characteristics are warranted when the device is operated within these ranges.

Always use semiconductor devices within their recommended operating condition ranges. Operation outside these ranges may adversely affect reliability and could result in device failure.

No warranty is made with respect to uses, operating conditions, or combinations not represented on the data sheet. Users considering application outside the listed conditions are advised to contact their FUJITSU representatives beforehand.

# MB90340 Series

## 3. DC Characteristics

( $T_A = -40\text{ }^\circ\text{C}$  to  $+105\text{ }^\circ\text{C}$ ,  $V_{CC} = 5.0\text{ V} \pm 10\%$ ,  $V_{SS} = AV_{SS} = 0\text{ V}$ )

Parameter	Symbol	Pin	Condition	Value			Unit	Remarks
				Min	Typ	Max		
Input H voltage (At $V_{CC} = 5\text{ V} \pm 10\%$ )	$V_{IHS}$	—	—	$0.8 V_{CC}$	—	$V_{CC} + 0.3$	V	Port inputs if CMOS hysteresis input levels are selected (except UART SIN input pins and I <sup>2</sup> C input pins)
	$V_{IHA}$	—	—	$0.8 V_{CC}$	—	$V_{CC} + 0.3$	V	Port inputs if AUTOMOTIVE input levels are selected
	$V_{IHT}$	—	—	2.0	—	$V_{CC} + 0.3$	V	Port inputs if TTL input levels are selected
	$V_{IHS}$	—	—	$0.7 V_{CC}$	—	$V_{CC} + 0.3$	V	UART SIN inputs if CMOS input levels are selected
	$V_{IHI}$	—	—	$0.7 V_{CC}$	—	$V_{CC} + 0.3$	V	I <sup>2</sup> C Port inputs if CMOS hysteresis input levels are selected
	$V_{IHR}$	—	—	$0.8 V_{CC}$	—	$V_{CC} + 0.3$	V	$\overline{RST}$ input pin (CMOS hysteresis)
	$V_{IHM}$	—	—	$V_{CC} - 0.3$	—	$V_{CC} + 0.3$	V	MD input pin
Input L voltage (At $V_{CC} = 5\text{ V} \pm 10\%$ )	$V_{ILS}$	—	—	$V_{SS} - 0.3$	—	$0.2 V_{CC}$	V	Port inputs if CMOS hysteresis input levels are selected (except UART SIN input pins and I <sup>2</sup> C input pins)
	$V_{ILA}$	—	—	$V_{SS} - 0.3$	—	$0.5 V_{CC}$	V	Port inputs if AUTOMOTIVE input levels are selected
	$V_{ILT}$	—	—	$V_{SS} - 0.3$	—	0.8	V	Port inputs if TTL input levels are selected
	$V_{ILS}$	—	—	$V_{SS} - 0.3$	—	$0.3 V_{CC}$	V	UART SIN inputs if CMOS input levels are selected
	$V_{ILI}$	—	—	$V_{SS} - 0.3$	—	$0.3 V_{CC}$	V	I <sup>2</sup> C Port inputs if CMOS hysteresis input levels are selected
	$V_{ILR}$	—	—	$V_{SS} - 0.3$	—	$0.2 V_{CC}$	V	$\overline{RST}$ input pin (CMOS hysteresis)
	$V_{ILM}$	—	—	$V_{SS} - 0.3$	—	$V_{SS} + 0.3$	V	MD input pin
Output H voltage	$V_{OH}$	Normal outputs	$V_{CC} = 4.5\text{ V}$ , $I_{OH} = -4.0\text{ mA}$	$V_{CC} - 0.5$	—	—	V	
Output H voltage	$V_{OHI}$	I <sup>2</sup> C current outputs	$V_{CC} = 4.5\text{ V}$ , $I_{OH} = -3.0\text{ mA}$	$V_{CC} - 0.5$	—	—	V	
Output L voltage	$V_{OL}$	Normal outputs	$V_{CC} = 4.5\text{ V}$ , $I_{OL} = 4.0\text{ mA}$	—	—	0.4	V	
Output L voltage	$V_{OLI}$	I <sup>2</sup> C current outputs	$V_{CC} = 4.5\text{ V}$ , $I_{OL} = 3.0\text{ mA}$	—	—	0.4	V	

(Continued)

# MB90340 Series

(Continued)

( $T_A = -40\text{ }^\circ\text{C}$  to  $+105$ ,  $V_{CC} = 5.0\text{ V} \pm 10\%$ ,  $V_{SS} = AV_{SS} = 0\text{ V}$ )

Parameter	Symbol	Pin	Condition	Value			Unit	Remarks
				Min	Typ	Max		
Input leak current	$I_{IL}$	—	$V_{CC} = 5.5\text{ V}$ , $V_{SS} < V_I < V_{CC}$	-1	—	1	$\mu\text{A}$	
Pull-up resistance	$R_{UP}$	P00 to P07, P10 to P17, P20 to P27, P30 to P37, $\overline{RST}$	—	25	50	100	$\text{k}\Omega$	
Pull-down resistance	$R_{DOWN}$	MD2	—	25	50	100	$\text{k}\Omega$	Except Flash devices
Power supply current*	$I_{CC}$	$V_{CC}$	$V_{CC} = 5.0\text{ V}$ , Internal frequency : 24 MHz, At normal operation.	—	55	70	$\text{mA}$	MB90F347
			$V_{CC} = 5.0\text{ V}$ , Internal frequency : 24 MHz, At writing FLASH memory.	—	70	85	$\text{mA}$	MB90F347
			$V_{CC} = 5.0\text{ V}$ , Internal frequency : 24 MHz, At erasing FLASH memory.	—	75	90	$\text{mA}$	MB90F347
	$I_{CCS}$		$V_{CC} = 5.0\text{ V}$ , Internal frequency : 24 MHz, At Sleep mode.	—	25	35	$\text{mA}$	MB90F347
	$I_{CTS}$		$V_{CC} = 5.0\text{ V}$ , Internal frequency : 2 MHz, At Main Timer mode	—	0.3	0.8	$\text{mA}$	MB90F347
	$I_{CTSPLL6}$		$V_{CC} = 5.0\text{ V}$ , Internal frequency : 24 MHz, At PLL Timer mode, external frequency = 4 MHz	—	4	7	$\text{mA}$	MB90F347
	$I_{CCL}$		$V_{CC} = 5.0\text{ V}$ Internal frequency: 8 kHz, At sub operation $T_A = +25^\circ\text{C}$	—	170	360	$\mu\text{A}$	MB90F347
	$I_{CCLS}$		$V_{CC} = 5.0\text{ V}$ Internal frequency: 8 kHz, At sub sleep $T_A = +25^\circ\text{C}$	—	20	50	$\mu\text{A}$	MB90F347
	$I_{CCT}$		$V_{CC} = 5.0\text{ V}$ Internal frequency: 8 kHz, At watch mode $T_A = +25^\circ\text{C}$	—	10	60	$\mu\text{A}$	MB90F347
	$I_{CCH}$		$V_{CC} = 5.0\text{ V}$ , At Stop mode, $T_A = +25^\circ\text{C}$	—	7	100	$\mu\text{A}$	MB90F347
Input capacity	$C_{IN}$	Other than C, $AV_{CC}$ , $AV_{SS}$ , $AVRH$ , $AVRL$ , $V_{CC}$ , $V_{SS}$ ,	—	—	5	15	$\text{pF}$	

\* : Current values are tentative. They are subject to change without notice according to improvements in the characteristics. The power supply current is measured with an external clock.

## 4. AC Characteristics

### (1) Clock Timing

( $T_A = -40\text{ }^\circ\text{C}$  to  $+105\text{ }^\circ\text{C}$ ,  $V_{CC} = 5.0\text{ V} \pm 10\%$ ,  $V_{SS} = AV_{SS} = 0\text{ V}$ )

Parameter	Symbol	Pin	Value			Unit	Remarks
			Min	Typ	Max		
Clock frequency	$f_c$	X0, X1	3	—	16	MHz	When using an oscillation circuit
		X0, X1	3	—	24	MHz	When using an external clock*
	$f_{CL}$	X0A, X1A	—	32.768	100	kHz	
Clock cycle time	$t_{CYL}$	X0, X1	62.5	—	333	ns	When using an oscillation circuit
		X0, X1	41.67	—	333	ns	When using an external clock
	$t_{CYLL}$	X0A, X1A	10	30.5	—	$\mu\text{s}$	
Input clock pulse width	$P_{WH}, P_{WL}$	X0	10	—	—	ns	Duty ratio is about 30% to 70%.
	$P_{WHL}, P_{WLL}$	X0A	5	15.2	—	$\mu\text{s}$	
Input clock rise and fall time	$t_{CR}, t_{CF}$	X0	—	—	5	ns	When using external clock
Internal operating clock frequency (machine clock)	$f_{CP}$	—	1.5	—	24	MHz	When using main clock
	$f_{CPL}$	—	—	8.192	50	kHz	When using sub clock
Internal operating clock cycle time (machine clock)	$t_{CP}$	—	41.67	—	666	ns	When using main clock
	$t_{CPL}$	—	20	122.1	—	$\mu\text{s}$	When using sub clock

\* : When selecting the PLL clock, the range of clock frequency is limited. Use this product within range as mentioned in "Relation among external clock frequency and machine clock frequency".

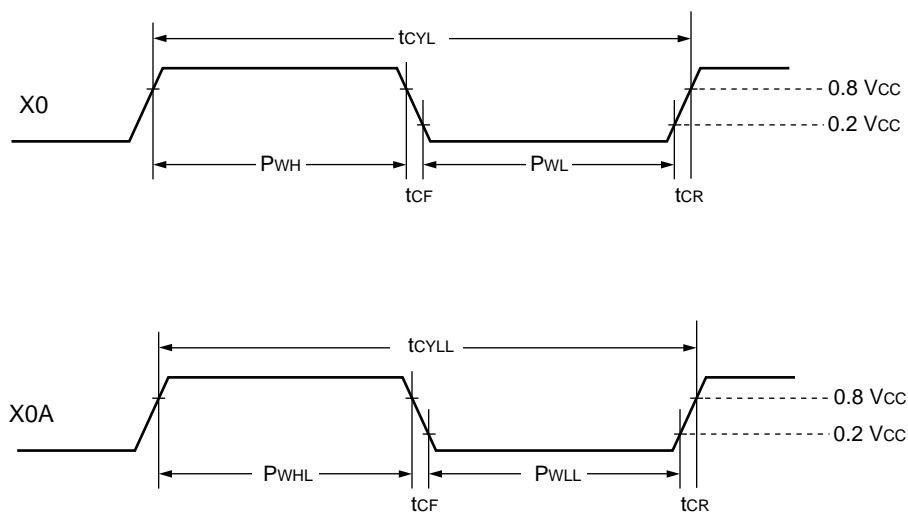

**Clock Timing**

# MB90340 Series

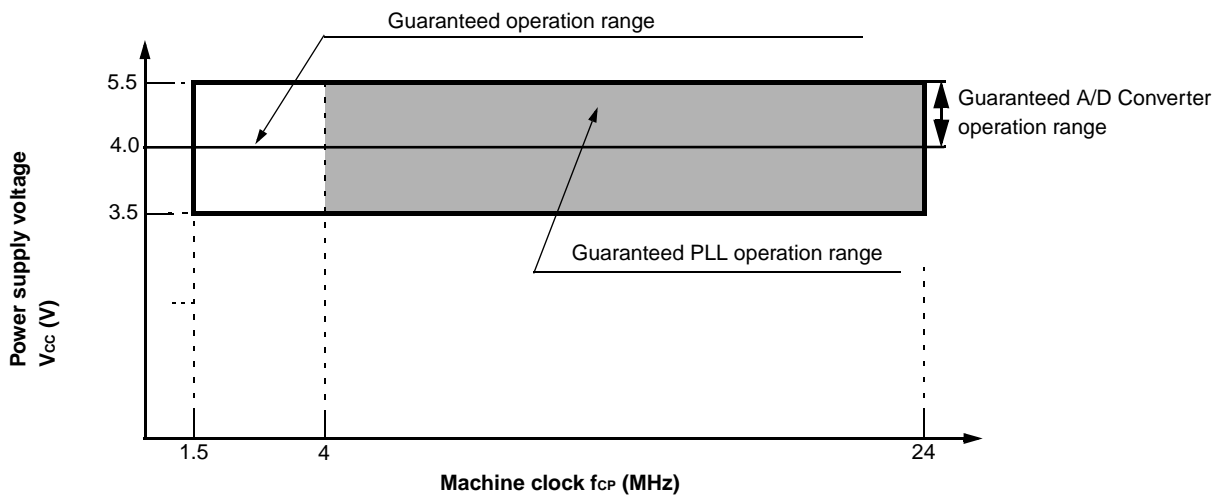

**Guaranteed operation range of MB90340 series**

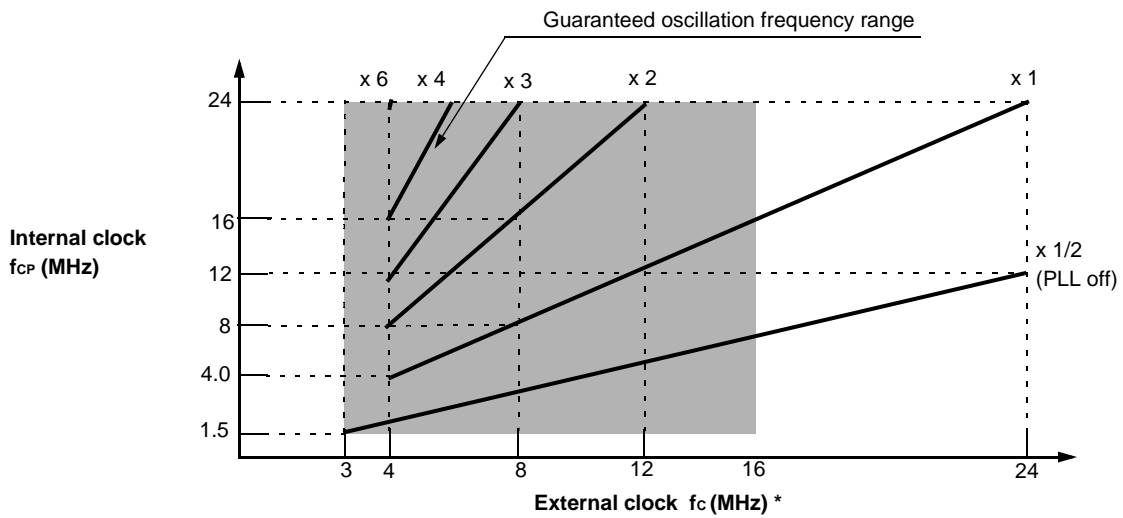

\* : When using the oscillation circuit, the maximum oscillation clock frequency is 16 MHz

**External clock frequency and Machine clock frequency**



## (2) Reset Standby Input

( $T_A = -40\text{ }^\circ\text{C}$  to  $+105\text{ }^\circ\text{C}$ ,  $V_{CC} = 5.0\text{ V} \pm 10\%$ ,  $V_{SS} = AV_{SS} = 0.0\text{ V}$ )

Parameter	Symbol	Pin	Value		Unit	Remarks	
			Min	Max			
Reset input time	$t_{RSTL}$	$\overline{RST}$	500	—	ns	Under normal operation	
			Oscillation time of oscillator* + 100 $\mu\text{s}$		—	ns	In Stop mode, Sub Clock mode, Sub Sleep mode and Watch mode
			100	—	$\mu\text{s}$	In Time Timer mode	

\* : Oscillation time of oscillator is the time that the amplitude reaches 90%.

In the crystal oscillator, the oscillation time is between several ms and to tens of ms. In FAR / ceramic oscillators, the oscillation time is between hundreds of  $\mu\text{s}$  to several ms. With an external clock, the oscillation time is 0 ms.

Under normal operation:

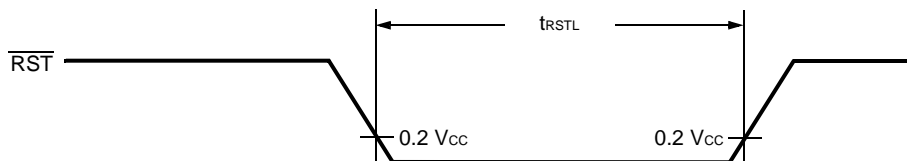

In Stop mode, Sub Clock mode, Sub Sleep mode, Watch mode:

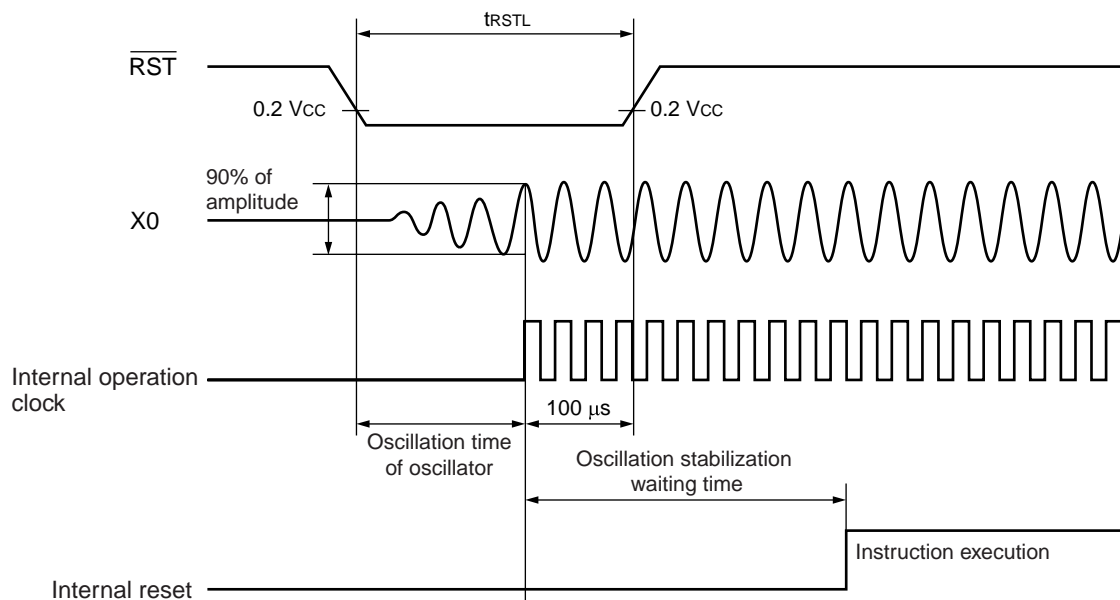

# MB90340 Series

## (3) Power On Reset

( $T_A = -40\text{ }^\circ\text{C}$  to  $+105\text{ }^\circ\text{C}$ ,  $V_{CC} = 5.0\text{ V} \pm 10\%$ ,  $V_{SS} = AV_{SS} = 0.0\text{ V}$ )

Parameter	Symbol	Pin	Condition	Value		Unit	Remarks
				Min	Max		
Power on rise time	$t_R$	$V_{CC}$	—	0.05	30	ms	
Power off time	$t_{OFF}$	$V_{CC}$	—	1	—	ms	Due to repetitive operation

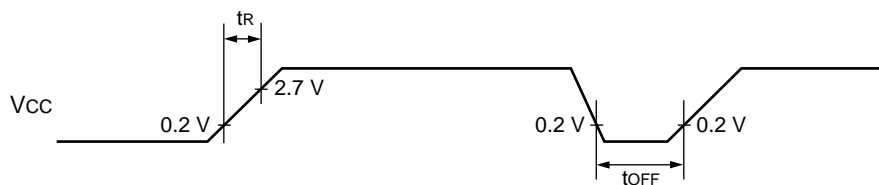

If you change the power supply voltage too rapidly, a power on reset may occur. We recommend that you startup smoothly by restraining voltages when changing the power supply voltage during operation, as shown in the figure below. Perform while not using the PLL clock. However, if voltage drops are within 1 V/s, you can operate while using the PLL clock.

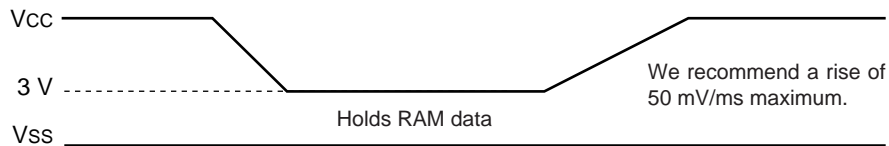

## (4) Bus Timing (Read)

( $T_A = -40^{\circ}\text{C}$  to  $+85^{\circ}\text{C}$ ,  $V_{CC} = 4.5\text{ V}$  to  $5.5\text{ V}$ ,  $V_{SS} = 0.0\text{ V}$ , Machine Clock  $\leq 16\text{ MHz}$ )

Parameter	Symbol	Pin	Condition	Value		Unit	Remarks
				Min	Max		
ALE pulse width	$t_{LHLL}$	ALE	—	$t_{CP}/2 - 10$	—	ns	
Valid address $\Rightarrow$ ALE $\downarrow$ time	$t_{AVLL}$	ALE, A23 to A16, AD15 to AD00		$t_{CP}/2 - 15$	—	ns	
ALE $\downarrow \Rightarrow$ Address valid time	$t_{LLAX}$	ALE, AD15 to AD00		$t_{CP}/2 - 15$	—	ns	
Valid address $\Rightarrow \overline{RD} \downarrow$ time	$t_{AVRL}$	A23 to A16, AD15 to AD00, $\overline{RD}$		$t_{CP} - 15$	—	ns	
Valid address $\Rightarrow$ Valid data input	$t_{AVDV}$	A23 to A16, AD15 to AD00		—	$5 t_{CP}/2 - 40$	ns	
$\overline{RD}$ pulse width	$t_{RLRH}$	$\overline{RD}$		$3 t_{CP}/2 - 20$	—	ns	
$\overline{RD} \downarrow \Rightarrow$ Valid data input	$t_{RLDV}$	$\overline{RD}$ , AD15 to AD00		—	$3 t_{CP}/2 - 50$	ns	
$\overline{RD} \uparrow \Rightarrow$ Data hold time	$t_{RHDX}$	$\overline{RD}$ , AD15 to AD00		0	—	ns	
$\overline{RD} \downarrow \Rightarrow$ ALE $\uparrow$ time	$t_{RHLH}$	$\overline{RD}$ , ALE		$t_{CP}/2 - 15$	—	ns	
$\overline{RD} \uparrow \Rightarrow$ Address valid time	$t_{RHAX}$	$\overline{RD}$ , A23 to A16		$t_{CP}/2 - 10$	—	ns	
Valid address $\Rightarrow$ CLK $\uparrow$ time	$t_{AVCH}$	A23 to A16, AD15 to AD00, CLK		$t_{CP}/2 - 15$	—	ns	
$\overline{RD} \downarrow \Rightarrow$ CLK $\uparrow$ time	$t_{RLCH}$	$\overline{RD}$ , CLK		$t_{CP}/2 - 15$	—	ns	
ALE $\downarrow \Rightarrow \overline{RD} \downarrow$ time	$t_{LLRL}$	ALE, $\overline{RD}$		$t_{CP}/2 - 15$	—	ns	

# MB90340 Series

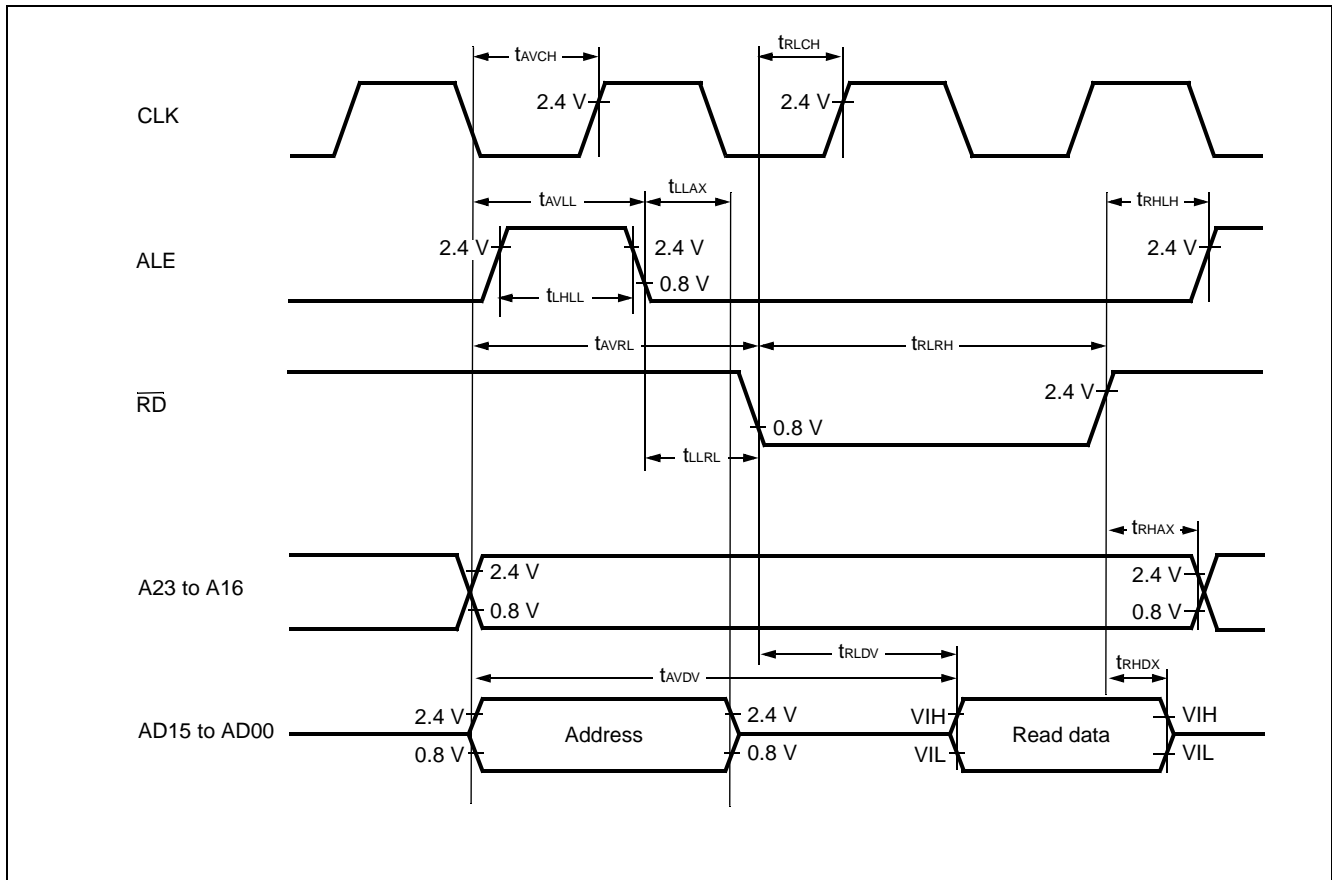

## (5) Bus Timing (Write)

( $T_A = -40^{\circ}\text{C}$  to  $+85^{\circ}\text{C}$ ,  $V_{CC} = 4.5\text{ V}$  to  $5.5\text{ V}$ ,  $V_{SS} = 0.0\text{ V}$ , Machine Clock  $\leq 16\text{ MHz}$ )

Parameter	Symbol	Pin	Condition	Value		Unit	Remarks
				Min	Max		
Valid address $\Rightarrow \overline{\text{WR}} \downarrow$ time	$t_{AVWL}$	A23 to A16, AD15 to AD00, $\overline{\text{WR}}$	—	$t_{CP}-15$	—	ns	
$\overline{\text{WR}}$ pulse width	$t_{WLWH}$	$\overline{\text{WR}}$		$3 t_{CP}/2 - 20$	—	ns	
Valid data output $\Rightarrow \overline{\text{WR}} \uparrow$ time	$t_{DVWH}$	AD15 to AD00, $\overline{\text{WR}}$		$3 t_{CP}/2 - 20$	—	ns	
$\overline{\text{WR}} \uparrow \Rightarrow$ Data hold time	$t_{WHDX}$	AD15 to AD00, $\overline{\text{WR}}$		15	—	ns	
$\overline{\text{WR}} \uparrow \Rightarrow$ Address valid time	$t_{WHAX}$	A23 to A16, $\overline{\text{WR}}$		$t_{CP}/2 - 10$	—	ns	
$\overline{\text{WR}} \uparrow \Rightarrow$ ALE $\uparrow$ time	$t_{WHLH}$	$\overline{\text{WR}}$ , ALE		$t_{CP}/2 - 15$	—	ns	
$\overline{\text{WR}} \downarrow \Rightarrow$ CLK $\uparrow$ time	$t_{WLCH}$	$\overline{\text{WR}}$ , CLK		$t_{CP}/2 - 15$	—	ns	

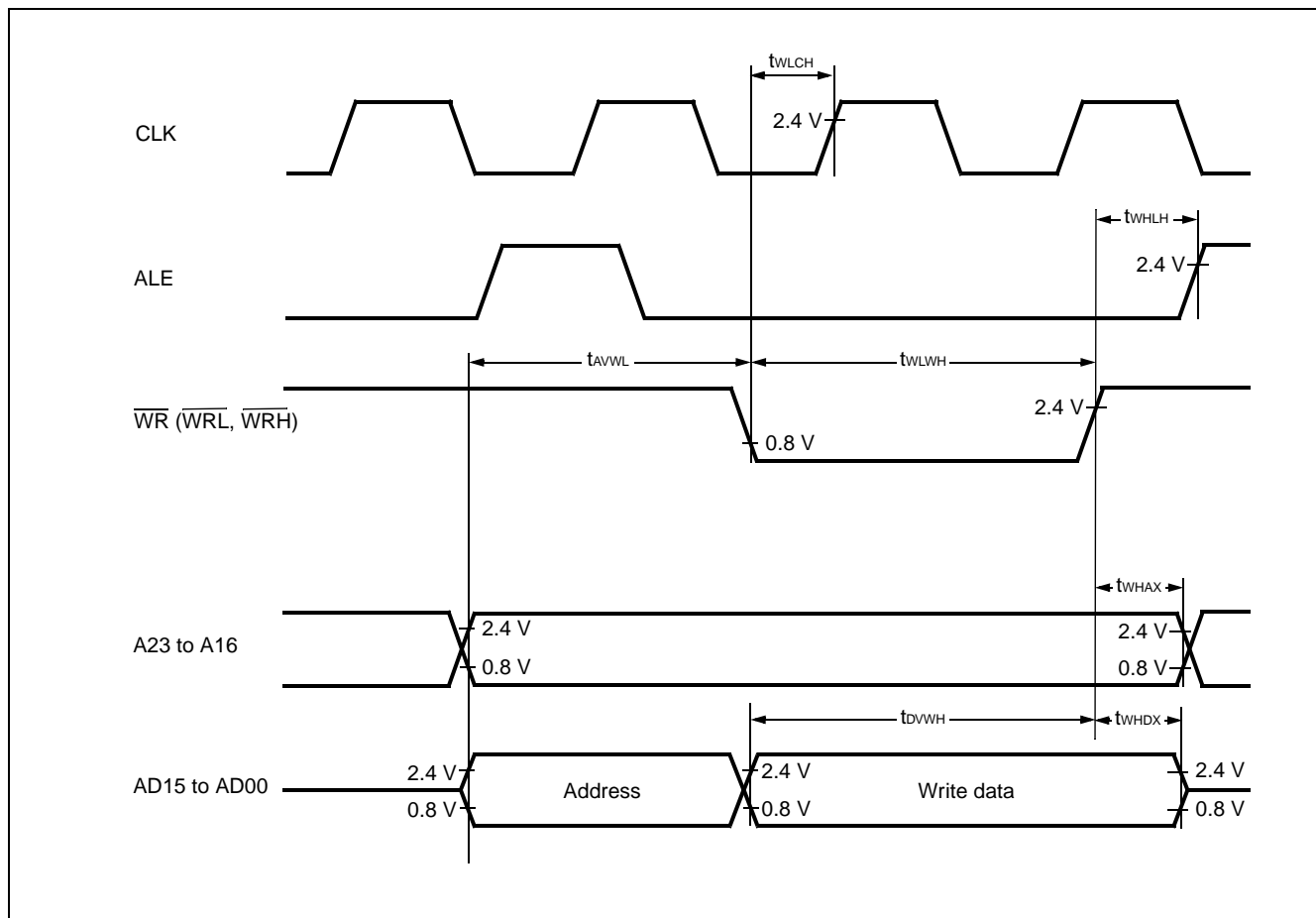

# MB90340 Series

## (6) Ready Input Timing

( $T_A = -40^{\circ}\text{C}$  to  $+85^{\circ}\text{C}$ ,  $V_{CC} = 4.5\text{ V}$  to  $5.5\text{ V}$ ,  $V_{SS} = 0.0\text{ V}$ , Machine Clock  $\leq 16\text{ MHz}$ )

Parameter	Symbol	Pin	Test Condition	Rated Value		Units	Remarks
				Min	Max		
RDY setup time	$t_{RYHS}$	RDY	—	45	—	ns	
RDY hold time	$t_{RYHH}$	RDY		0	—	ns	

Note : If the RDY setup time is insufficient, use the auto-ready function.

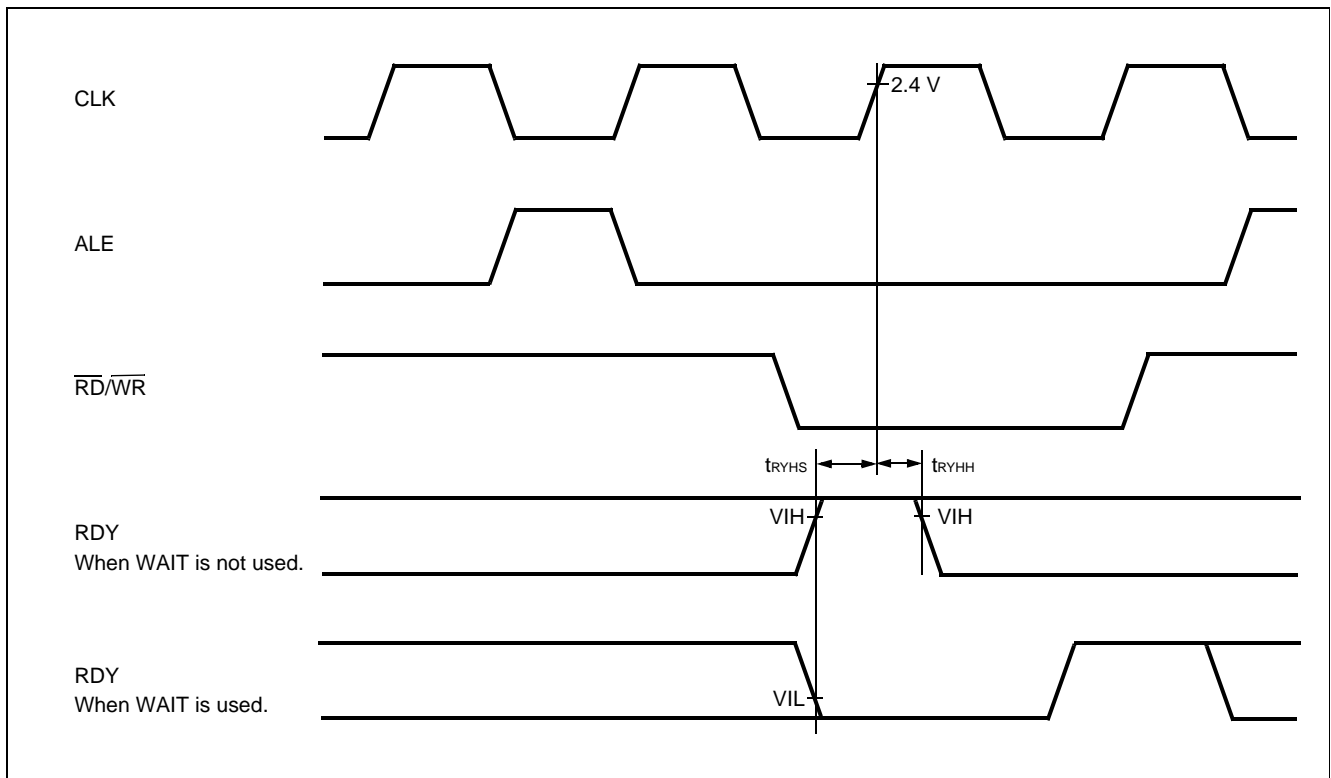

## (7) Hold Timing

( $T_A = -40^{\circ}\text{C}$  to  $+85^{\circ}\text{C}$ ,  $V_{CC} = 4.5\text{ V}$  to  $5.5\text{ V}$ ,  $V_{SS} = 0.0\text{ V}$ , Machine Clock  $\leq 16\text{ MHz}$ )

Parameter	Symbol	Pin	Condition	Value		Units	Remarks
				Min	Max		
Pin floating $\Rightarrow \overline{\text{HAK}} \downarrow$ time	$t_{\text{XHAL}}$	$\overline{\text{HAK}}$	—	30	$t_{\text{CP}}$	ns	
$\overline{\text{HAK}} \uparrow$ time $\Rightarrow$ Pin valid time	$t_{\text{HAHV}}$	$\overline{\text{HAK}}$		$t_{\text{CP}}$	$2 t_{\text{CP}}$	ns	

Note : There is more than 1 cycle from when HRQ reads in until the  $\overline{\text{HAK}}$  is changed.

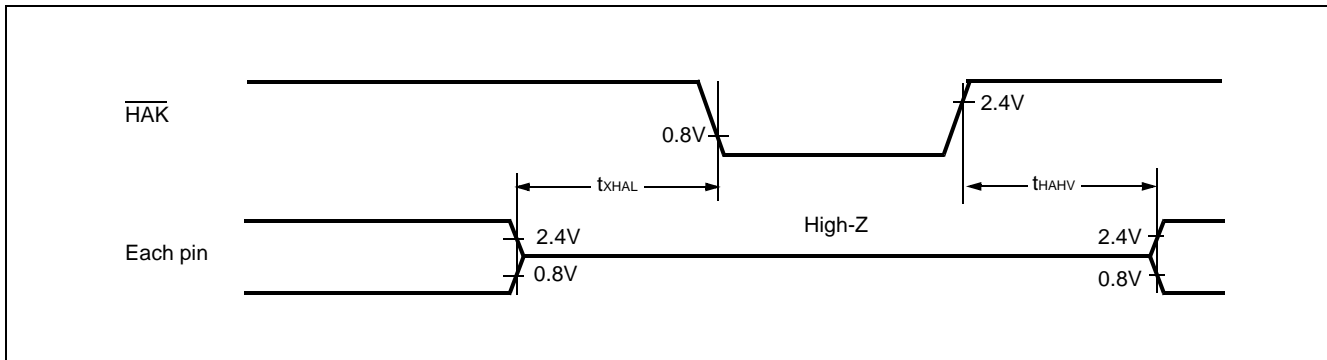

# MB90340 Series

## (8) UART0/1/2/3/4

( $T_A = -40\text{ }^\circ\text{C}$  to  $+105\text{ }^\circ\text{C}$ ,  $V_{CC} = 4.5\text{ V}$  to  $5.5\text{ V}$ ,  $V_{SS} = 0\text{ V}$ )

Parameter	Symbol	Pin	Condition	Value		Unit	Remarks
				Min	Max		
Serial clock cycle time	$t_{SCYC}$	SCK0 to SCK4	Internal clock operation output pins are $C_L = 80\text{ pF} + 1\text{ TTL}$ .	$8\ t_{CP}^*$	—	ns	
SCK ↓ → SOT delay time	$t_{SLOV}$	SCK0 to SCK4, SOT0 to SOT4		-80	+80	ns	
Valid SIN → SCK ↑	$t_{IVSH}$	SCK0 to SCK4, SIN0 to SIN4		100	—	ns	
SCK ↑ → Valid SIN hold time	$t_{SHIX}$	SCK0 to SCK4, SIN0 to SIN4		60	—	ns	
Serial clock "H" pulse width	$t_{SHSL}$	SCK0 to SCK4	External clock operation output pins are $C_L = 80\text{ pF} + 1\text{ TTL}$ .	$4\ t_{CP}^*$	—	ns	
Serial clock "L" pulse width	$t_{SLSH}$	SCK0 to SCK4		$4\ t_{CP}^*$	—	ns	
SCK ↓ → SOT delay time	$t_{SLOV}$	SCK0 to SCK4, SOT0 to SOT4		—	150	ns	
Valid SIN → SCK ↑	$t_{IVSH}$	SCK0 to SCK4, SIN0 to SIN4		60	—	ns	
SCK ↑ → Valid SIN hold time	$t_{SHIX}$	SCK0 to SCK4, SIN0 to SIN4		60	—	ns	

\* : Refer to “ (1) Clock timing” rating for  $t_{CP}$  (internal operating clock cycle time).

- Notes :
- AC characteristic in CLK synchronized mode.
  - $C_L$  is load capacity value of pins when testing.
  - $t_{CP}$  is the machine cycle (Unit : ns)

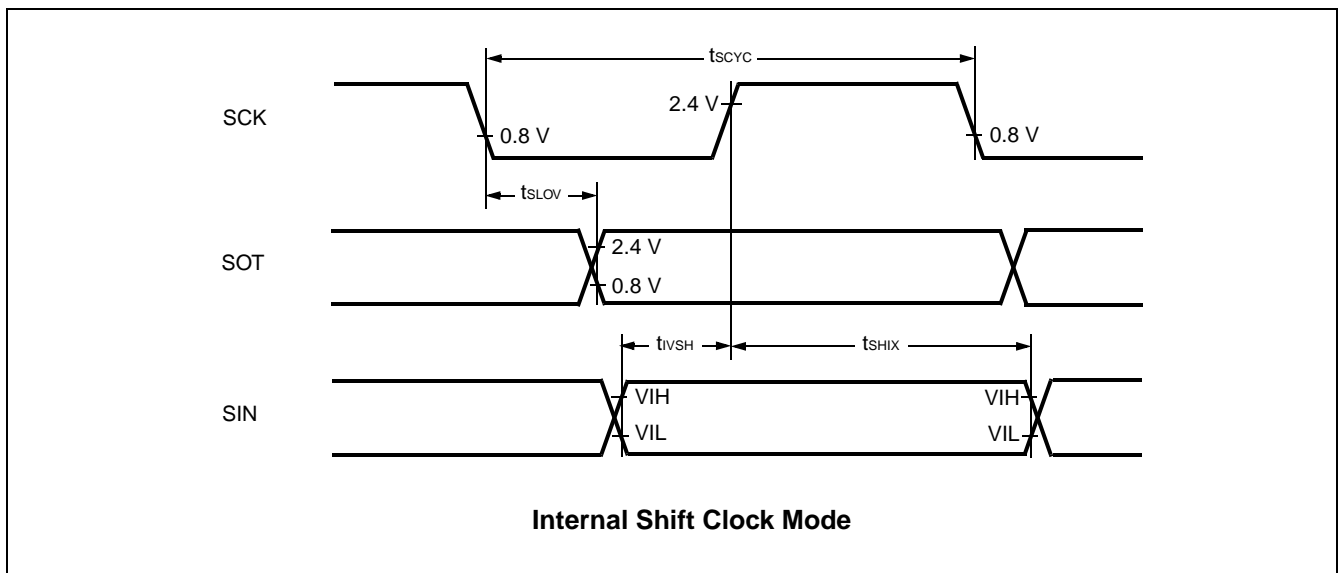



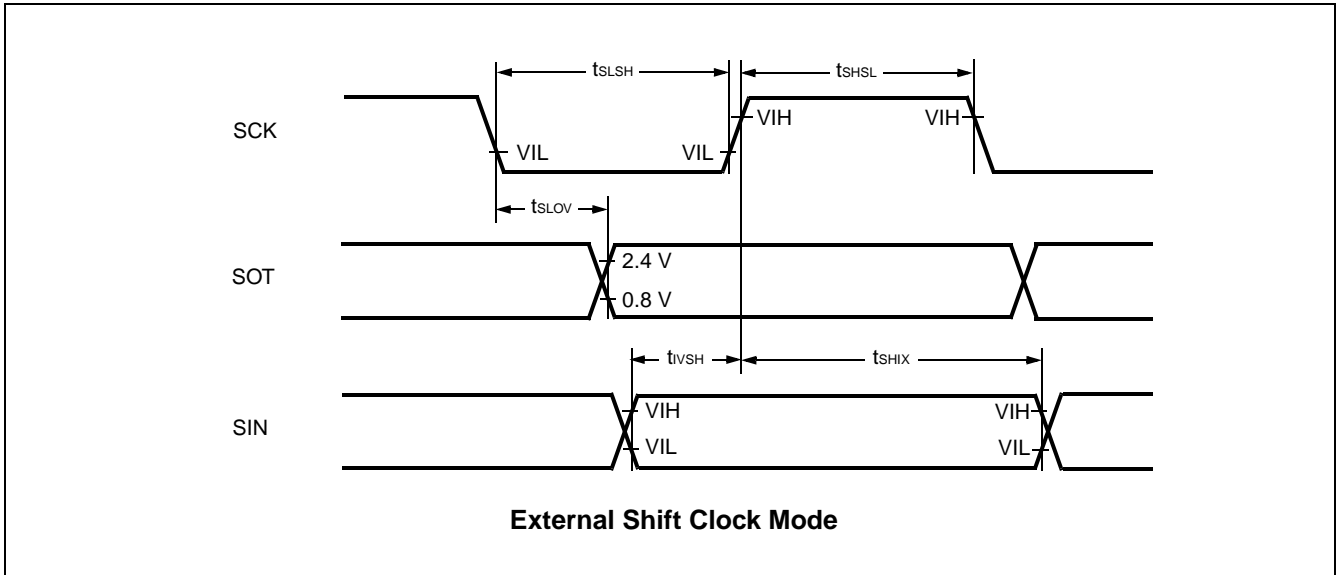

## (9) Trigger Input Timing

( $T_A = -40\text{ }^\circ\text{C}$  to  $+105\text{ }^\circ\text{C}$ ,  $V_{CC} = 4.5\text{ V}$  to  $5.5\text{ V}$ ,  $V_{SS} = 0\text{ V}$ )

Parameter	Symbol	Pin	Condition	Value		Unit	Remarks
				Min	Max		
Input pulse width	$t_{TRGH}$ $t_{TRGL}$	INT0 to INT15, INT0R to INT15R, ADTG	—	$5 t_{CP}$	—	ns	

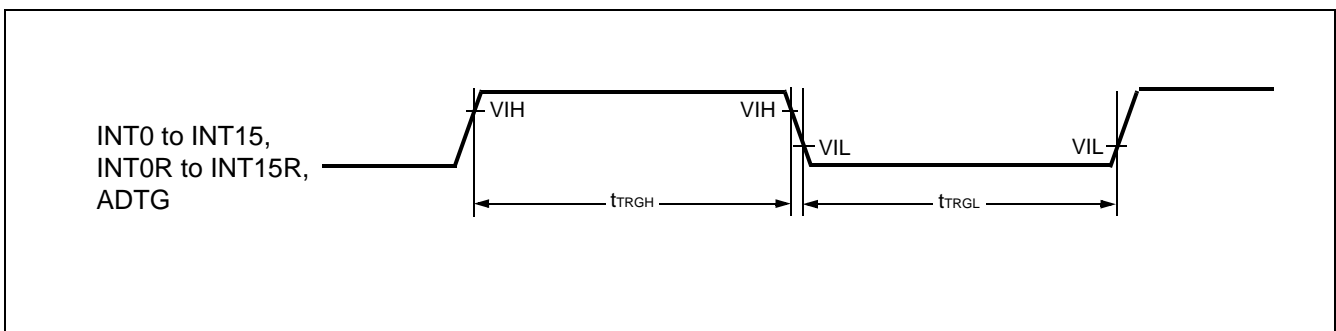

# MB90340 Series

## (10) Timer Related Resource Input Timing

( $T_A = -40\text{ }^\circ\text{C}$  to  $+105\text{ }^\circ\text{C}$ ,  $V_{CC} = 4.5\text{ V}$  to  $5.5\text{ V}$ ,  $V_{SS} = 0\text{ V}$ )

Parameter	Symbol	Pin	Condition	Value		Unit	Remarks
				Min	Max		
Input pulse width	$t_{TIWH}$	TIN0 to TIN3	—	4 $t_{CP}$	—	ns	
	$t_{TIWL}$	IN0 to IN7					

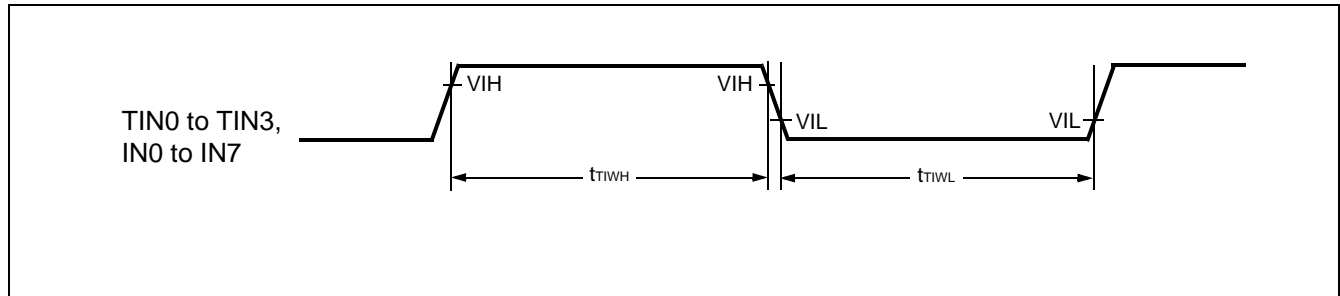

## (11) Timer Related Resource Output Timing

( $T_A = -40\text{ }^\circ\text{C}$  to  $+105\text{ }^\circ\text{C}$ ,  $V_{CC} = 4.5\text{ V}$  to  $5.5\text{ V}$ ,  $V_{SS} = 0.0\text{ V}$ )

Parameter	Symbol	Pin	Condition	Value		Unit	Remarks
				Min	Max		
CLK $\uparrow$ $\Rightarrow$ $T_{OUT}$ change time	$t_{ro}$	TOT0 to TOT3, PPG0 to PPGF	—	30	—	ns	

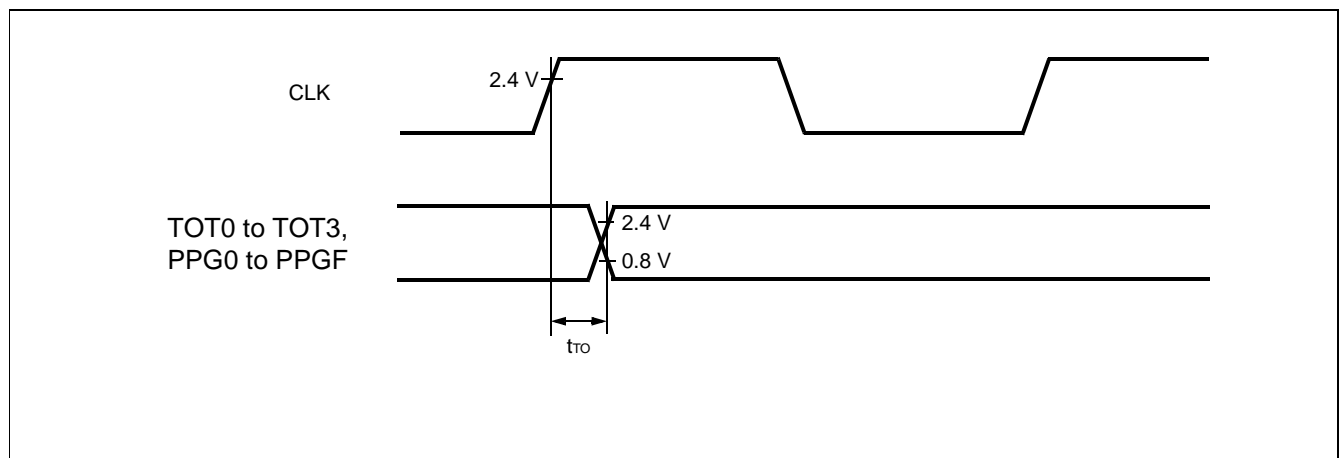

## 5. A/D Converter

( $T_A = -40\text{ }^\circ\text{C}$  to  $+105\text{ }^\circ\text{C}$ ,  $3.0\text{ V} \leq \text{AVRH} - \text{AVRL}$ ,  $V_{CC} = \text{AV}_{CC} = 5.0\text{ V} \pm 10\%$ ,  $V_{SS} = \text{AV}_{SS} = 0\text{ V}$ )

Parameter	Symbol	Pin	Value			Unit	Remarks
			Min	Typ	Max		
Resolution	—	—	—	—	10	bit	
Total error	—	—	—	—	$\pm 3.0$	LSB	
Nonlinearity error	—	—	—	—	$\pm 2.5$	LSB	
Differential nonlinearity error	—	—	—	—	$\pm 1.9$	LSB	
Zero reading voltage	$V_{OT}$	AN0 to AN23	$\text{AVRL} - 1.5$	$\text{AVRL} + 0.5$	$\text{AVRL} + 2.5$	LSB	
Full scale reading voltage	$V_{FST}$	AN0 to AN23	$\text{AVRH} - 3.5$	$\text{AVRH} - 1.5$	$\text{AVRH} + 0.5$	LSB	
Compare time	—	—	1.0	—	—	$\mu\text{s}$	$4.5\text{ V} \leq \text{AV}_{CC} \leq 5.5\text{ V}$
			2.0				$4.0\text{ V} \leq \text{AV}_{CC} \leq 4.5\text{ V}$
Sampling time	—	—	0.5	—	—	$\mu\text{s}$	$4.5\text{ V} \leq \text{AV}_{CC} \leq 5.5\text{ V}$
			1.2				$4.0\text{ V} \leq \text{AV}_{CC} \leq 4.5\text{ V}$
Analog port input current	$I_{AIN}$	AN0 to AN23	-0.3	—	+0.3	$\mu\text{A}$	
Analog input voltage range	$V_{AIN}$	AN0 to AN23	AVRL	—	AVRH	V	
Reference voltage range	—	AVRH	$\text{AVRL} + 2.7$	—	$\text{AV}_{CC}$	V	
	—	AVRL	0	—	$\text{AVRH} - 2.7$	V	
Power supply current	$I_A$	$\text{AV}_{CC}$	—	3.5	7.5	mA	
	$I_{AH}$	$\text{AV}_{CC}$	—	—	5	$\mu\text{A}$	*
Reference voltage current	$I_R$	AVRH	—	600	900	$\mu\text{A}$	
	$I_{RH}$	AVRH	—	—	5	$\mu\text{A}$	*
Offset between input channels	—	AN0 to AN23	—	—	4	LSB	

\* : When not operating A/D converter, this is the current ( $V_{CC} = \text{AV}_{CC} = \text{AVRH} = 5.0\text{ V}$ ) .

Note : The accuracy gets worse as  $\text{AVRH} - \text{AVRL}$  becomes smaller.

# MB90340 Series

## 6. Definition of A/D Converter Terms

- Resolution : Analog variation that is recognized by an A/D converter.
- Non linearity error : Deviation between a line across zero-transition line ( “00 0000 0000” ← → “00 0000 0001” ) and full-scale transition line ( “11 1111 1110” ← → “11 1111 1111” ) and actual conversion characteristics.
- Differential linearity error : Deviation of input voltage, which is required for changing output code by 1 LSB, from an ideal value.
- Total error : Difference between an actual value and an ideal value. A total error includes zero transition error, full-scale transition error, and linear error.
- Zero reading voltage : Input voltage which results in the minimum conversion value.
- Full scale reading voltage : Input voltage which results in the maximum conversion value.

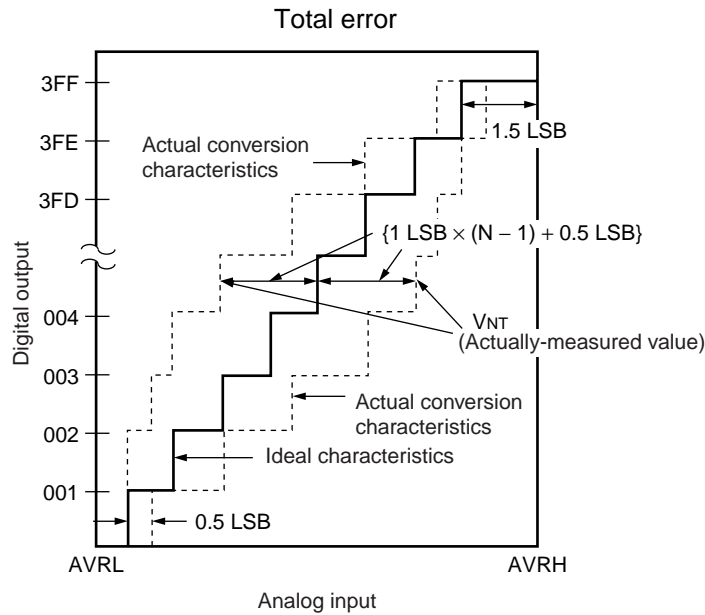

$$\text{Total error of digital output "N"} = \frac{V_{NT} - \{1 \text{ LSB} \times (N - 1) + 0.5 \text{ LSB}\}}{1 \text{ LSB}} \text{ [LSB]}$$

$$1 \text{ LSB} = (\text{Ideal value}) \frac{AVRH - AVRL}{1024} \text{ [V]}$$

$$V_{OT} (\text{Ideal value}) = AVRL + 0.5 \text{ LSB [V]}$$

$$V_{FST} (\text{Ideal value}) = AVRH - 1.5 \text{ LSB [V]}$$

$V_{NT}$  : A voltage at which digital output transitions from (N - 1) to N.

(Continued)

(Continued)

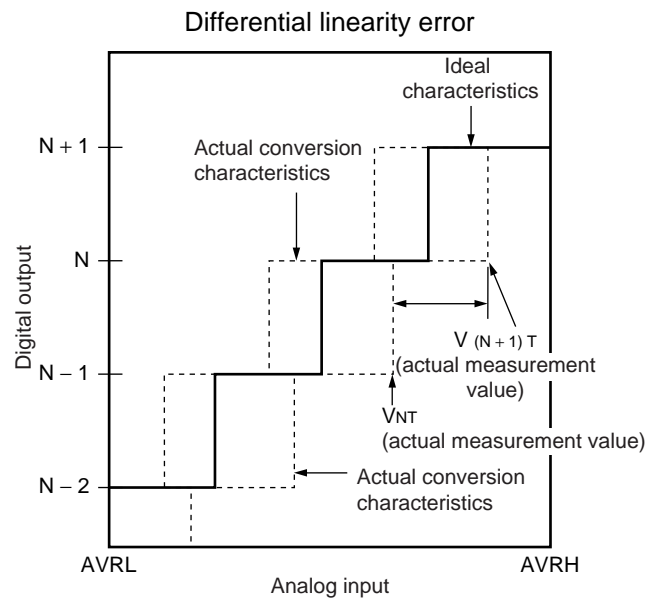
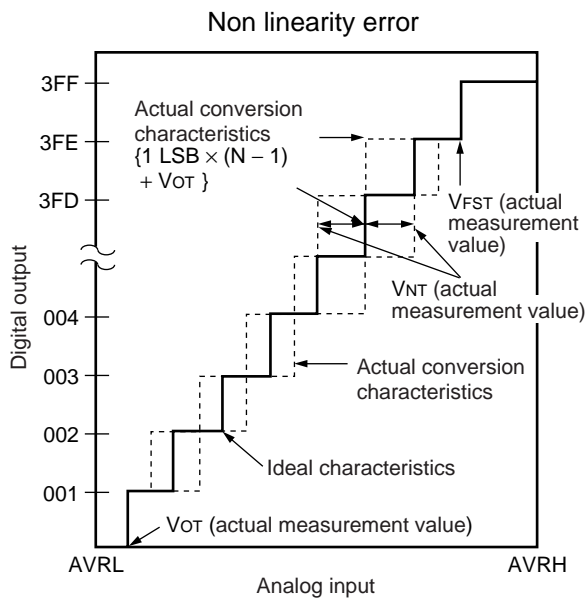

$$\text{Non linearity error of digital output } N = \frac{V_{NT} - \{1 \text{ LSB} \times (N - 1) + V_{OT}\}}{1 \text{ LSB}} \text{ [LSB]}$$

$$\text{Differential linearity error of digital output } N = \frac{V_{(N+1)T} - V_{NT}}{1 \text{ LSB}} - 1 \text{ LSB [LSB]}$$

$$1 \text{ LSB} = \frac{V_{FST} - V_{OT}}{1022} \text{ [V]}$$

$V_{OT}$  : Voltage at which digital output transits from "000<sub>H</sub>" to "001<sub>H</sub>."

$V_{FST}$  : Voltage at which digital output transits from "3FE<sub>H</sub>" to "3FF<sub>H</sub>."

# MB90340 Series

## 7. Notes on A/D Converter Section

Use the device with external circuits of the following output impedance for analog inputs :

Recommended output impedance of external circuits are : Approx. 1.5 kΩ or lower ( $4.0\text{ V} \leq AV_{CC} \leq 5.5\text{ V}$ , sampling period  $\leq 0.5\text{ }\mu\text{s}$ )

If an external capacitor is used, in consideration of the effect by tap capacitance caused by external capacitors and on-chip capacitors, capacitance of the external one is recommended to be several thousand times as high as internal capacitor.

If output impedance of an external circuit is too high, a sampling period for an analog voltage may be insufficient.

- Analog input circuit model

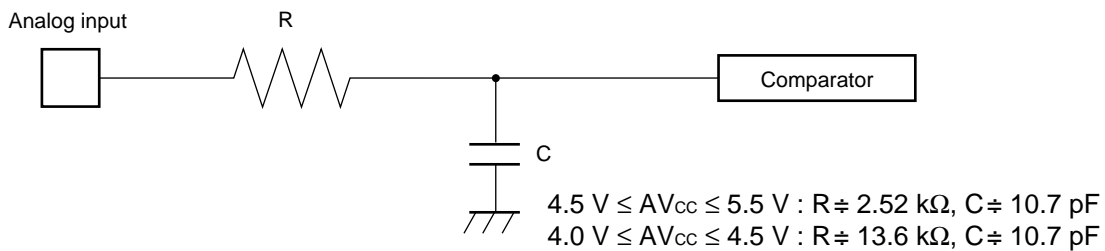

Note : Use the values in the figure only as a guideline.

## 8. Flash Memory Program/Erase Characteristics

Parameter	Conditions	Value			Unit	Remarks
		Min	Typ	Max		
Sector erase time	$T_A = +25\text{ }^\circ\text{C}$ $V_{CC} = 5.0\text{ V}$	—	1	15	s	Excludes programming prior to erasure
Chip erase time		—	9	—	s	Excludes programming prior to erasure
Word (16 bit width) programming time		—	16	3,600	$\mu\text{s}$	Except for the over head time of the system
Programs/Erase cycle	—	10,000	—	—	cycle	

## ■ ORDERING INFORMATION

Part number	Package	Remarks
MB90F342PF	100-pin Plastic QFP (FPT-100P-M06)	
MB90F342SPF		
MB90F342CPF		
MB90F342CSPF		
MB90F342PFV	100-pin Plastic LQFP (FPT-100P-M05)	
MB90F342SPFV		
MB90F342CPFV		
MB90F342CSPFV		
MB90F343PF	100-pin Plastic QFP (FPT-100P-M06)	
MB90F343SPF		
MB90F343CPF		
MB90F343CSPF		
MB90F343PFV	100-pin Plastic LQFP (FPT-100P-M05)	
MB90F343SPFV		
MB90F343CPFV		
MB90F343CSPFV		
MB90F345PF	100-pin Plastic QFP (FPT-100P-M06)	
MB90F345SPF		
MB90F345CPF		
MB90F345CSPF		
MB90F345PFV	100-pin Plastic LQFP (FPT-100P-M05)	
MB90F345SPFV		
MB90F345CPFV		
MB90F345CSPFV		
MB90F346PF	100-pin Plastic QFP (FPT-100P-M06)	
MB90F346SPF		
MB90F346CPF		
MB90F346CSPF		
MB90F346PFV	100-pin Plastic LQFP (FPT-100P-M05)	
MB90F346SPFV		
MB90F346CPFV		
MB90F346CSPFV		

(Continued)

# MB90340 Series

Part number	Package	Remarks
MB90F347PF	100-pin Plastic QFP (FPT-100P-M06)	
MB90F347SPF		
MB90F347CPF		
MB90F347CSPF		
MB90F347PFV	100-pin Plastic LQFP (FPT-100P-M05)	
MB90F347SPFV		
MB90F347CPFV		
MB90F347CSPFV		
MB90F349PF	100-pin Plastic QFP (FPT-100P-M06)	
MB90F349SPF		
MB90F349CPF		
MB90F349CSPF		
MB90F349PFV	100-pin Plastic LQFP (FPT-100P-M05)	
MB90F349SPFV		
MB90F349CPFV		
MB90F349CSPFV		
MB90341PF	100-pin Plastic QFP (FPT-100P-M06)	
MB90341SPF		
MB90341CPF		
MB90341CSPF		
MB90341PFV	100-pin Plastic LQFP (FPT-100P-M05)	
MB90341SPFV		
MB90341CPFV		
MB90341CSPFV		
MB90342PF	100-pin Plastic QFP (FPT-100P-M06)	
MB90342SPF		
MB90342CPF		
MB90342CSPF		
MB90342PFV	100-pin Plastic LQFP (FPT-100P-M05)	
MB90342SPFV		
MB90342CPFV		
MB90342CSPFV		

(Continued)



# MB90340 Series

(Continued)

Part number	Package	Remarks	
MB90346PF	100-pin Plastic QFP (FPT-100P-M06)		
MB90346SPF			
MB90346CPF			
MB90346CSPF			
MB90346PFV	100-pin Plastic LQFP (FPT-100P-M05)		
MB90346SPFV			
MB90346CPFV			
MB90346CSPFV			
MB90347PF	100-pin Plastic QFP (FPT-100P-M06)		
MB90347SPF			
MB90347CPF			
MB90347CSPF			
MB90347PFV	100-pin Plastic LQFP (FPT-100P-M05)		
MB90347SPFV			
MB90347CPFV			
MB90347CSPFV			
MB90348PF	100-pin Plastic QFP (FPT-100P-M06)		
MB90348SPF			
MB90348CPF			
MB90348CSPF			
MB90348PFV	100-pin Plastic LQFP (FPT-100P-M05)		
MB90348SPFV			
MB90348CPFV			
MB90348CSPFV			
MB90349PF	100-pin Plastic QFP (FPT-100P-M06)		
MB90349SPF			
MB90349CPF			
MB90349CSPF			
MB90349PFV	100-pin Plastic LQFP (FPT-100P-M05)		
MB90349SPFV			
MB90349CPFV			
MB90349CSPFV			
MB90V340	299-pin Ceramic PGA (PGA-299C-A01)	For evaluation	

# MB90340 Series

## ■ PACKAGE DIMENSIONS

100-pin Plastic QFP  
(FPT-100P-M06)

Note 1) \* : These dimensions do not include resin protrusion.  
 Note 2) Pins width and pins thickness including plating thickness.  
 Note 3) Pins width do not include tie bar cutting remainder.

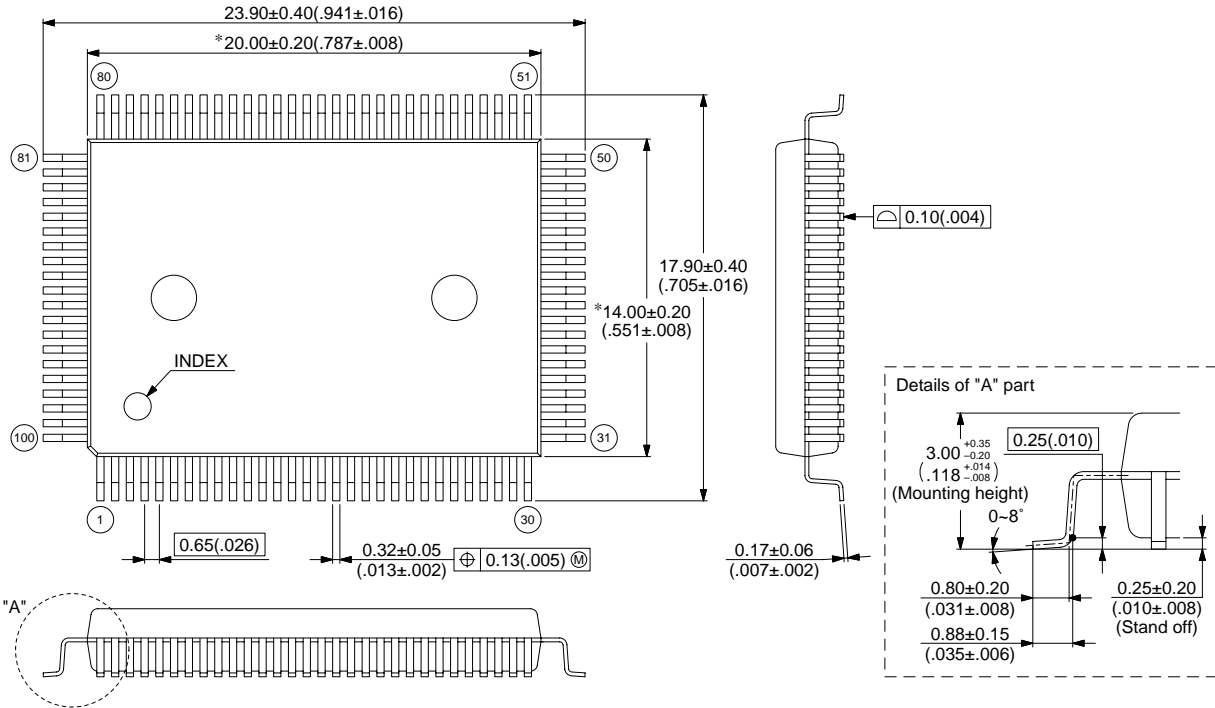

© 2002 FUJITSU LIMITED F100008S-c-5-5

Dimensions in mm (inches)

Note : The values in parentheses are reference values.

(Continued)

# MB90340 Series

(Continued)

100-pin Plastic LQFP  
(FPT-100P-M05)

Note 1) \* : These dimensions do not include resin protrusion.  
 Note 2) Pins width and pins thickness include plating thickness.  
 Note 3) Pins width do not include tie bar cutting remainder.

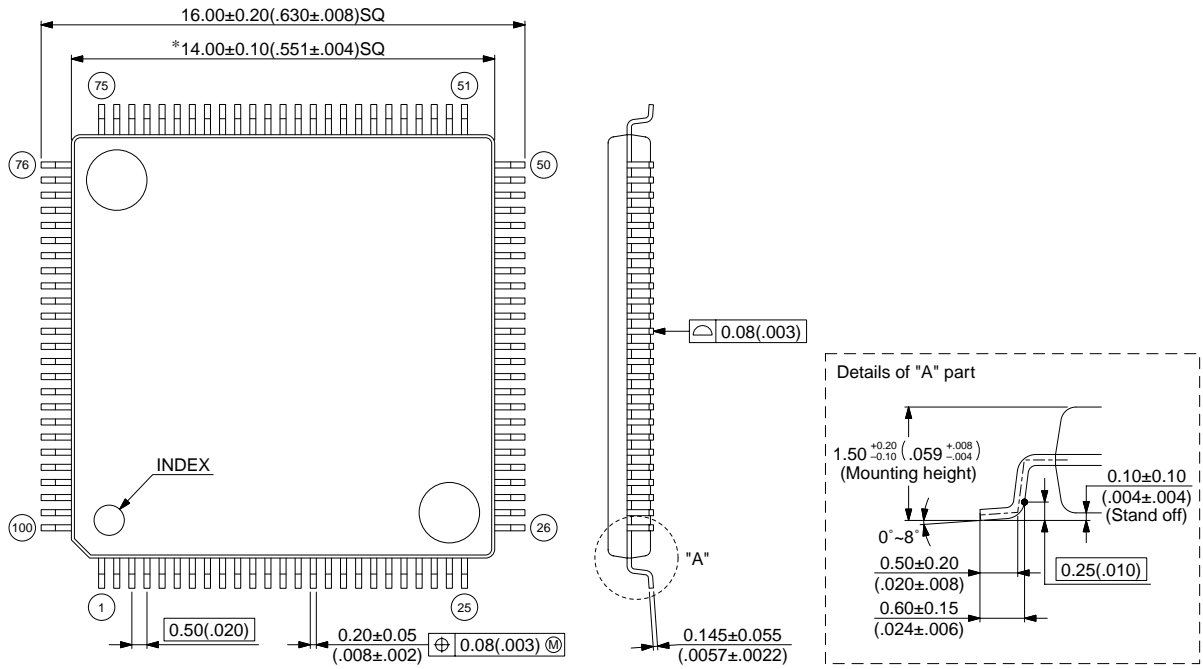

© 2003 FUJITSU LIMITED F100007S-c-4-6

Dimensions in mm (inches)

Note : The values in parentheses are reference values.

## FUJITSU LIMITED

All Rights Reserved.

The contents of this document are subject to change without notice. Customers are advised to consult with FUJITSU sales representatives before ordering.

The information, such as descriptions of function and application circuit examples, in this document are presented solely for the purpose of reference to show examples of operations and uses of Fujitsu semiconductor device; Fujitsu does not warrant proper operation of the device with respect to use based on such information. When you develop equipment incorporating the device based on such information, you must assume any responsibility arising out of such use of the information. Fujitsu assumes no liability for any damages whatsoever arising out of the use of the information.

Any information in this document, including descriptions of function and schematic diagrams, shall not be construed as license of the use or exercise of any intellectual property right, such as patent right or copyright, or any other right of Fujitsu or any third party or does Fujitsu warrant non-infringement of any third-party's intellectual property right or other right by using such information. Fujitsu assumes no liability for any infringement of the intellectual property rights or other rights of third parties which would result from the use of information contained herein.

The products described in this document are designed, developed and manufactured as contemplated for general use, including without limitation, ordinary industrial use, general office use, personal use, and household use, but are not designed, developed and manufactured as contemplated (1) for use accompanying fatal risks or dangers that, unless extremely high safety is secured, could have a serious effect to the public, and could lead directly to death, personal injury, severe physical damage or other loss (i.e., nuclear reaction control in nuclear facility, aircraft flight control, air traffic control, mass transport control, medical life support system, missile launch control in weapon system), or (2) for use requiring extremely high reliability (i.e., submersible repeater and artificial satellite).

Please note that Fujitsu will not be liable against you and/or any third party for any claims or damages arising in connection with above-mentioned uses of the products.

Any semiconductor devices have an inherent chance of failure. You must protect against injury, damage or loss from such failures by incorporating safety design measures into your facility and equipment such as redundancy, fire protection, and prevention of over-current levels and other abnormal operating conditions.

If any products described in this document represent goods or technologies subject to certain restrictions on export under the Foreign Exchange and Foreign Trade Law of Japan, the prior authorization by Japanese government will be required for export of those products from Japan.