

### 64K x 18 Fast CMOS Synchronous Static SRAM with Interleaved Burst Counter and Output Register

#### Features

- 1 Interfaces directly with the i486<sup>™</sup>, Pentium<sup>™</sup> processors (100, 80, 60, 50 MHz)
- 1 High Speed Clock Rates  
10, 12.5, 15, 20 ns  
- Cycle Times:  
10, 12.5, 15, 20 ns
- 1 High Density 64K x 18 Architecture
- 1 Output Register for Pipelined Designs
- 1 Choice of 5V or 3V  $\pm 10\%$  Output Vcc for output level compatibility
- 1 High Output Drive: 30 pF at Rated Taa
- 1 Asynchronous Output Enable
- 1 Self Timed Write Cycle
- 1 Byte Writeable via Dual Write Strokes
- 1 Internal interleaved burst read/write address counter
- 1 Internal registers for Address, Data, Controls
- 1 Packages: 52-pin PLCC

#### Description

The PDM44058 is a 1,179,648 bit synchronous random access memory organized as 65,536 words by 18 bits. It has burst mode capability, an output register and interface controls designed to provide high performance in secondary cache designs for i486 and Pentium<sup>™</sup> microprocessors. Addresses, write data and all control signals except output enable are controlled through positive edge triggered registers. Write cycles are self timed and are also initiated by the rising edge of the clock. Controls are provided to allow burst reads and writes of up to four words in length. A two-bit burst address counter controls the two least significant bits of the address during burst reads and writes. The burst address counter uses the 2-bit counting scheme required by the i486 and Pentium<sup>™</sup> microprocessors. Individual write strobes provide byte write for the upper and lower 9-bit bytes of data. An asynchronous output enable simplifies interface to high speed buses. Separate output Vcc pins provide user controlled output

6

#### Functional Block Diagram

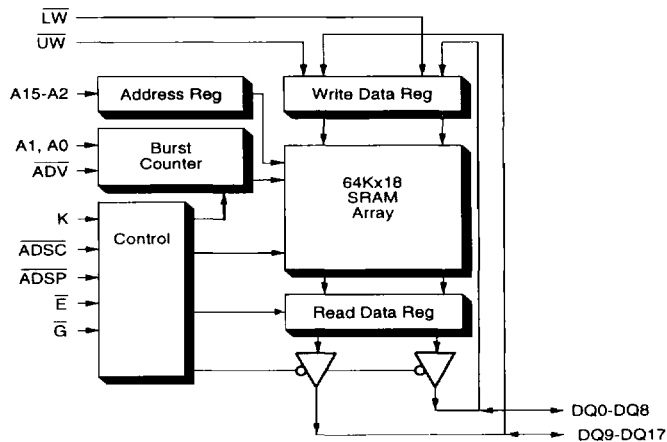

<sup>™</sup> i486, Pentium are trademarks of Intel Corp.

Pin Assignment

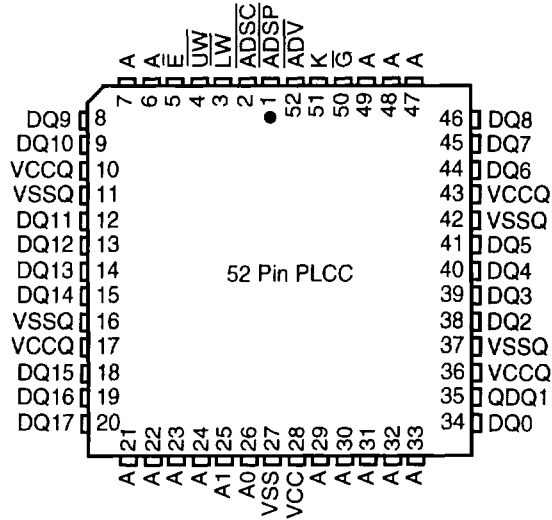

Pinout

Name	I/O	Description	Name	I/O	Description
A	I	Address Inputs A15-A2	LW	I	Low Byte Write Enable, DQ0-DQ8
A1, A0	I	Address Inputs A1 & A0	UW	I	Upper Byte Write Enable, DQ8-DQ17
DQ0-DQ17	I/O	Read/Write Data	G	I	Output Enable
K	I	Clock	VCC	—	Array Power (+5V)
ADV	I	Burst Counter Advance	VCCQ	—	Output Power for DQ's (+3.3V or +5V)
ADSC	I	Controller Address Status	VSS	—	Array Ground
ADSP	I	Processor Address Status	VSSQ	—	Output Ground for DQ's
E	I	Chip Enable			

Asynchronous Truth Table

Operation	G	I/O Status
Read	L	Data Out
Read	H	High-Z
Write	X	High-Z: Write Data In
Deselected	X	High-Z

Burst Sequence Table

Sequence	A15-A2	A1	A0
Start Address	AAAA	B	C
1st Burst Address	AAAA	B	C
2nd Burst Address	AAAA	B	C
3rd Burst Address	AAAA	B	C

- NOTE: 1. X means Don't Care.  
 2. For a write operation following a read operation, G must be high before the input data required setup time and held high through the input data hold time.

**Synchronous Truth Table** (See Notes 1 through 4)

E	ADSP	ADSC	ADV	UW or LW	K	Address	Operation
H	X	L	X	X	↑	N/A	Deselected
L	L	X	X	X	↑	External	Read Cycle, Begin Burst
L	H	L	X	L	↑	External	Write Cycle, Begin Burst
L	H	L	X	H	↑	External	Read Cycle, Begin Burst
X	H	H	L	L	↑	Next	Write Cycle, Continue Burst
X	H	H	L	H	↑	Next	Read Cycle, Continue Burst
X	H	H	H	L	↑	Current	Write Cycle, Suspend Burst
X	H	H	H	H	↑	Current	Read Cycle, Suspend Burst
H	X	H	L	L	↑	Next	Write Cycle, Continue Burst
H	X	H	L	H	↑	Next	Read Cycle, Continue Burst
H	X	H	H	L	↑	Current	Write Cycle, Suspend Burst
H	X	H	H	H	↑	Current	Read Cycle, Suspend Burst

- NOTE:
1. X means Don't Care.
  2. All inputs except G must meet setup and hold times relative low-to-high transition of clock, K.
  3. Wait states are inserted by suspending burst.
  4. ADSP is gated by E. Both ADSP and E must be valid for ADSP to load the address register and force a read.

**Burst Mode Operation**

This is a synchronous part. All activities are initiated by the positive, low-to-high edge of the clock (K). This part can perform burst reads and writes with burst lengths of up to 4 words. The 4 word burst is created by using a burst counter to drive the two least significant bits of the internal RAM address. The burst counter is loaded at the start of the burst and is incremented for each word of the burst. The burst counter uses a modified binary sequence compatible with the cache line burst reload sequence of i486 microprocessors. This sequence is given in the Burst Sequence Table.

Burst transfers are initiated by the ADSC or ADSP signals. When the ADSP and E signals are sampled low, a read cycle is started (independent of W and ADSC), and prior burst activity is terminated. ADSP is gated by E, so both must be active for ADSP to load the address register and to initiate a read cycle. The address and the chip enable input (E) are sampled by the same edge that samples ADSP. Read data is valid at the output after the specified delay from the clock edge.

When ADSC is sampled low and ADSP is sampled high, a read or write cycle is started depending on the state of UW or LW. If UW and LW are both sampled high, a read cycle is started, as described above. If UW or LW is sampled low, a write cycle is begun. The address, write data, and the chip enable input (E) are sampled by the same edge that samples ADSC and UW or LW. The ADV line is held high for this clock edge to maintain the correct address for the internal write operation which will follow this second clock edge.

After the first cycle of the write burst, The state of UW and LW determines whether the next cycle is a read or write cycle, and ADV controls the advance of the address counter. The address counter is advanced by the ADV signal. This increments the address to the next available RAM address. You write the next word in the burst by taking ADV low and presenting the write data at the positive edge of the clock. If ADV is sampled low, the burst counter advances and the write data -- which is sampled by the same clock -- is written into the internal RAM during the time following the clock edge.

This part has an output register. Output read data is available one cycle after the address register and burst counter have been loaded or incremented.



**Absolute Maximum Ratings**

Symbol	Rating	Com'l.	Unit
V <sub>TERM</sub>	Terminal Voltage with Respect to GND	-0.5 to +7.0	V
T <sub>A</sub>	Operating Temperature	0 to +70	°C
T <sub>BIAS</sub>	Temperature Under Bias	-55 to +125	°C
T <sub>STG</sub>	Storage Temperature	-55 to +125	°C
I <sub>OUT</sub>	DC Output Current	50	mA

NOTE: 1. Stresses greater than those listed under ABSOLUTE MAXIMUM RATINGS may cause permanent damage to the device. This is a stress rating only and functional operation of the device at these or any other conditions above those indicated in the operational sections of this specification is not implied. Exposure to absolute maximum rating conditions for extended periods may affect reliability.

**Recommended DC Operating Conditions**

Symbol	Description	Mln.	Typ.	Max.	Unit	
V <sub>CC</sub>	Supply Voltage	4.75	5.0	5.25	V	
V <sub>CCQ</sub>		5V	4.5	5.0	5.5	V
		3.3V	3.0	3.3	3.6	V
GND	Supply Voltage	0	0	0	V	
Industrial	Ambient Temperature	-40	25	85	°C	
Commercial	Ambient Temperature	0	25	70	°C	

**DC Electrical Characteristics** ( $V_{CC} = 5.0V \pm 5\%$ , All Temperature Ranges)

Symbol	Description	Test Conditions	Min.	Max.	Unit
$I_{LIL}$	Input Leakage Current	$V_{CC} = MAX., V_{IN} = GND \text{ to } V_{CC}$	—	1	$\mu A$
$I_{LOL}$	Output Leakage Current	$V_{CC} = MAX., V_{OUT} = GND \text{ to } V_{CC}$	—	1	$\mu A$
$V_{OL}$	Output Low Voltage	$V_{CC} = Min., I_{OL} = 8 \text{ mA}$	0	0.4	V
$V_{OH}$	Output High Voltage	$V_{CC} = Min., I_{OH} = -4 \text{ mA}$	2.4	$V_{CCQ}$	V
$V_{IH}$	Input HIGH Voltage		2.2	6	V
$V_{IL}$	Input LOW Voltage (1)		-0.5	0.8	V

NOTE: 1. Undershoots to -1.5 for 10 ns are allowed once per cycle.

**Power Supply Characteristics**

Symbol	Description	Test Conditions	-10 ns	-12 ns	-15 ns	-20 ns	Unit	
$I_{CC1}$	Active Supply Current: Outputs Open	$V_{CC} = Max.,$ Inputs @ 0.0V or 3.0V $F = 1/T_{CYC}$ on Rclk & Wclk	Com'l.	360	360	360	360	mA
$I_{SB}$	Standby Current: Outputs Open	$V_{CC} = Max.,$ Inputs @ 0.0V or 3.0V $F = 1/T_{CYC}, E = V_{IH}$	Com'l.	120	120	110	110	mA

**Capacitance** ( $T_A = +25^\circ C, f = 1.0 \text{ MHz}$ )

Symbol	Parameter	Conditions	Max.	Unit
$C_{IN}$	Input Capacitance	$V_{IN} = 0V$	5	pF
$C_{OUT}$	Output Leakage Current	$V_{OUT} = 0V$	8	pF

NOTES: 1. Characterized values, not currently tested.  
2. With output deselected.

6

AC Test Conditions

Input Pulse Levels	GND to 3.0V
Input rise and fall times	3 ns
Input timing reference levels	1.5V
Output reference levels	1.5V
Output Load	See Figures 1 and 2

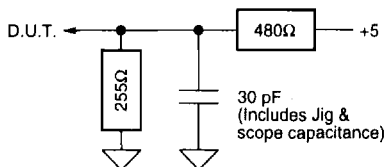

Figure 1a. Output Load

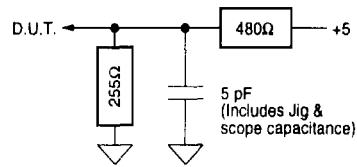

Figure 1b. Output Disable Timing Load

AC Electrical Characteristics (V<sub>CC</sub> = 5V ± 5%, All Temperature Ranges)

Parameter	Symbol	-10	-12	-15	-20	Type	Units	Notes
Clock Cycle time	t <sub>CYC</sub>	10	12.5	15	20	Min.	ns	
Clock to Data Valid (Std Load)	t <sub>CD</sub>	5	6	8	9	Max.	ns	5
Clock to Data Valid (0 pF Load)	t <sub>CD0</sub>	4	5	7	7	Min.	ns	
Output Enable	t <sub>OE</sub>	5	5	6	7	Max.	ns	
Clock to Data Low-Z	t <sub>dc1</sub>	3	3	3	3	Min.	ns	
Clock to Data Hold Time	t <sub>dc2</sub>	3	3	3	3	Min.	ns	
OE to Output Low-Z <sup>(1)</sup>	t <sub>OLZ</sub>	0	0	0	0	Min.	ns	1
OE to Output High-Z <sup>(1)</sup>	t <sub>OHZ</sub>	2	2	2	2	Min.	ns	1, 6
		5	5	6	7	Max.	ns	1, 6
Clock to Data High-Z	t <sub>CZ</sub>	6	6	7	8	Max.	ns	1, 6
Clock High/Low	t <sub>W</sub>	4	5	6	7	Min.	ns	
Setup Time	t <sub>S</sub>	2.5	2.5	2.5	3	Min.	ns	7
Hold Time	t <sub>H</sub>	0.5	0.5	0.5	0.5	Min.	ns	7

NOTES: 1. Values characterized and guaranteed by design, not currently tested.

2. A read cycle is defined by  $\overline{UW}$  and  $\overline{LW}$  high or  $\overline{ADSP}$  low for the setup and hold times. A write cycle is defined by  $\overline{LW}$  or  $\overline{UW}$  low and  $\overline{ADSP}$  high for the set up and hold times.
3. All read and write cycle timings are referenced from K or  $\overline{G}$ .
4.  $\overline{G}$  is a don't care when  $\overline{UW}$  or  $\overline{LW}$  is sampled low.
5. Maximum access times are guaranteed for all possible i486 external bus cycles.
6. Transition is measured ±500 mV from steady-state voltage with load of Figure 1B. This parameter is sampled rather than 100% tested. At any given voltage and temperature, t<sub>CHZ</sub> max is less than t<sub>CLZ</sub> min for a given device and from device to device.
7. This is a synchronous device. All addresses must meet the specified setup and hold times for ALL rising edges of K whenever  $\overline{ADSP}$  or  $\overline{ADSC}$  is low, and the chip is enabled. Chip enable must be valid at each rising edge of clock for the device (when  $\overline{ADSP}$  or  $\overline{ADSC}$  is low) to remain enabled.
8. This device has an output read data register. Read data is available one clock cycle after the address register and burst counter have been loaded or incremented.

ADSP Read Timing Diagram

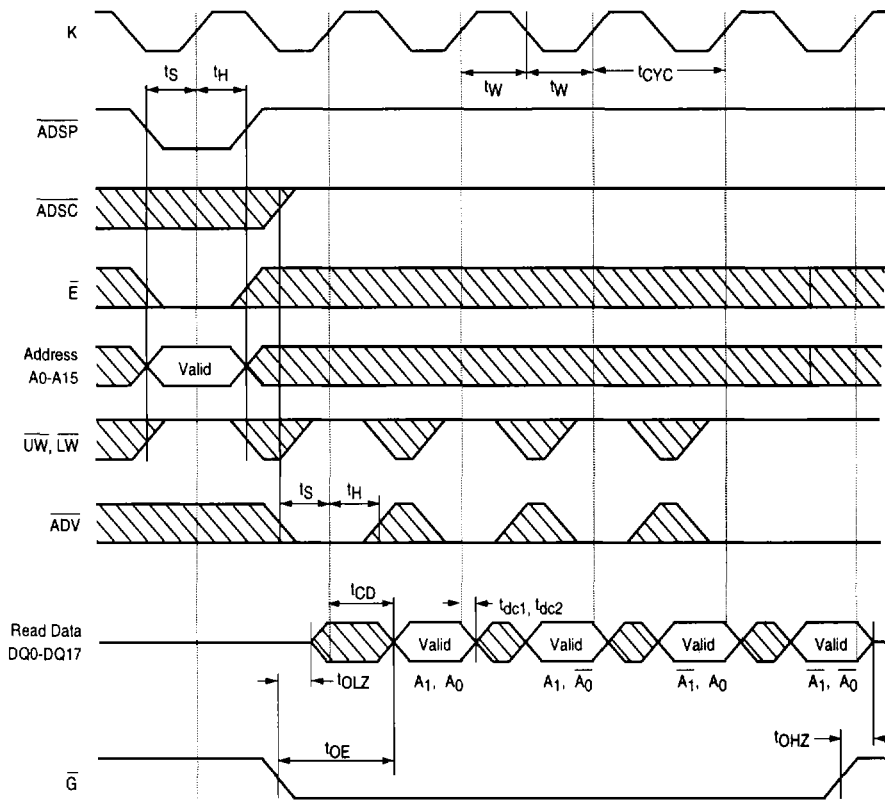

6

ADSP Write Timing Diagram

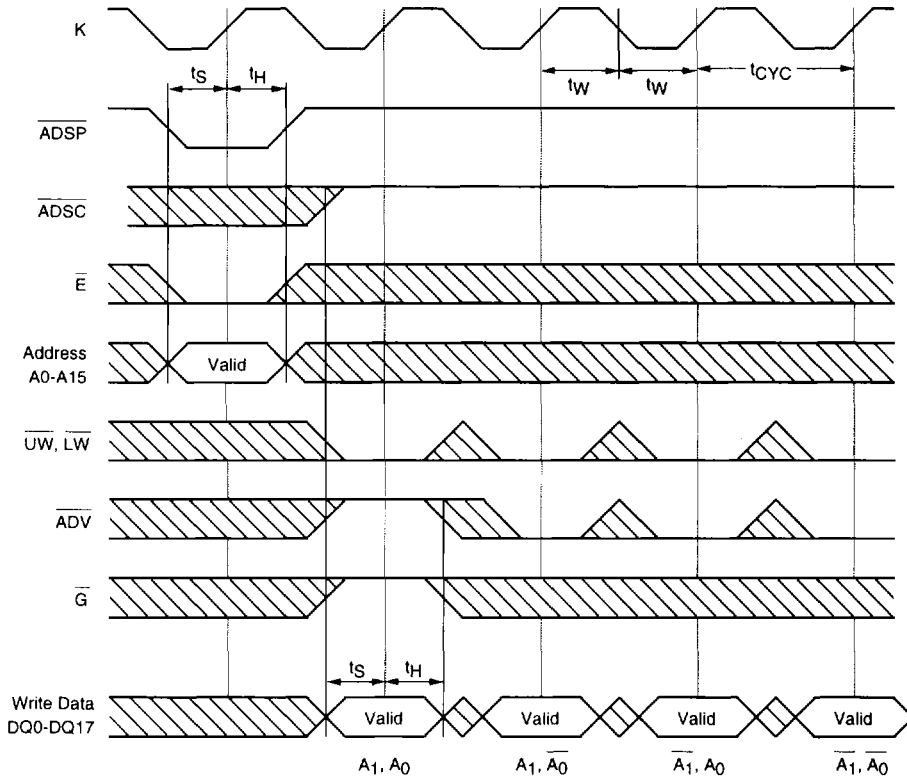

NOTE: UW and LW are ignored for the first cycle when ADSP initiates the burst. ADSP active loads a new address into the address counter and forces the first cycle to be a read cycle.



ADSC Read Timing Diagrams

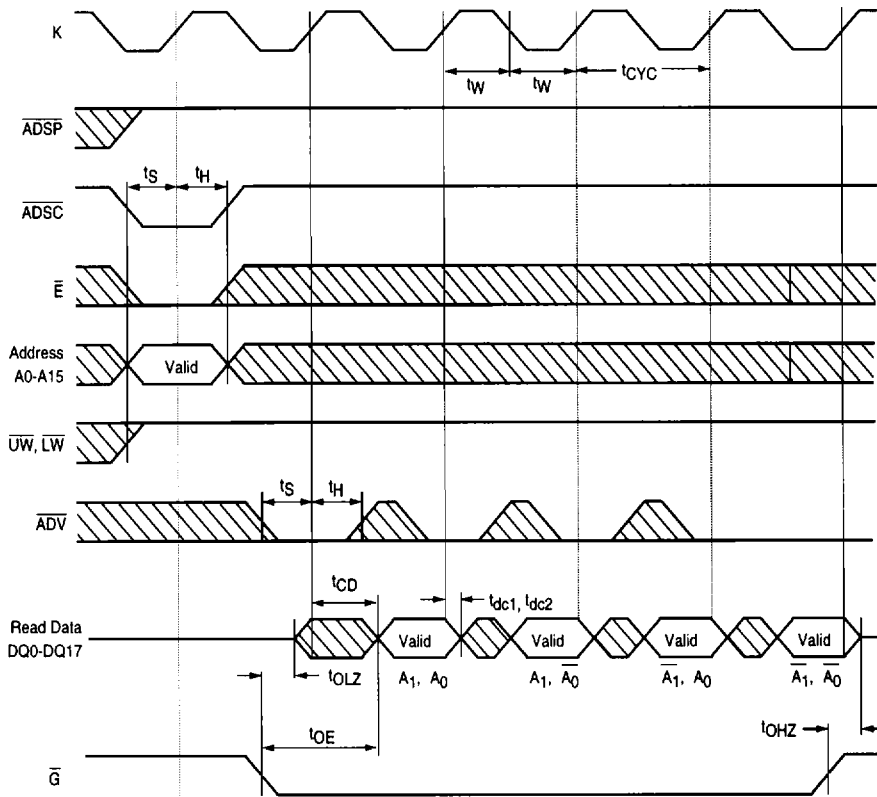

ADSC Write Timing Diagram

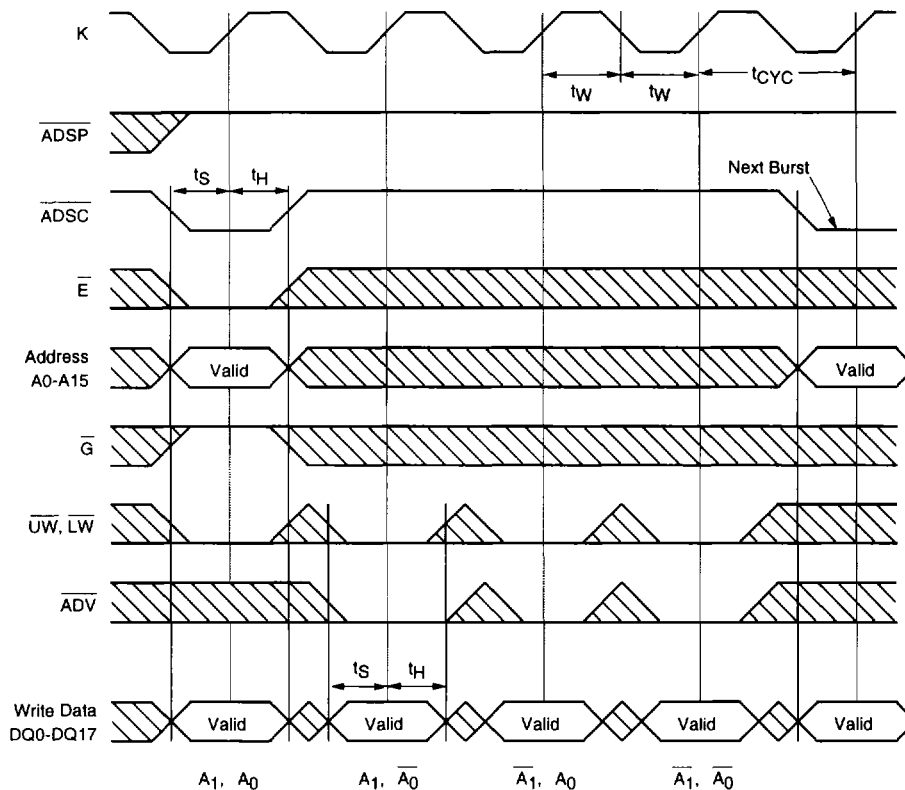

Ordering Information

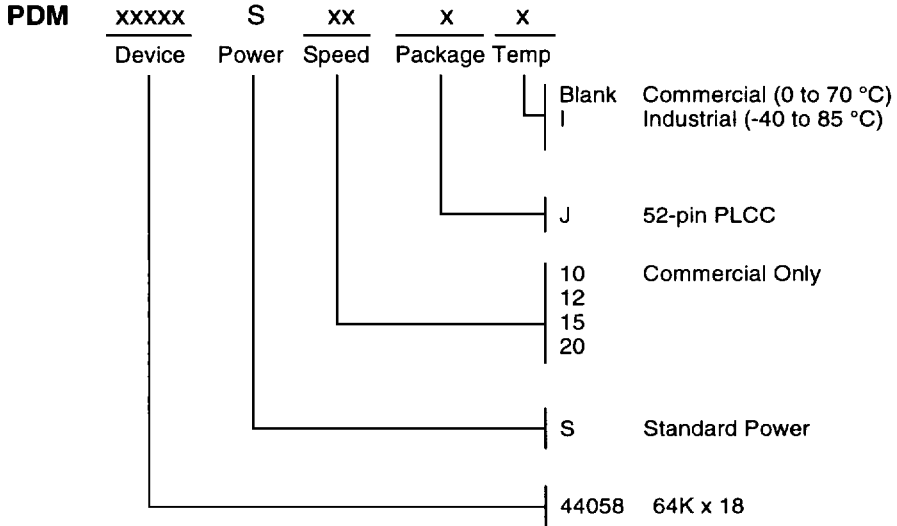

Chip	Description
PDM44058	52-pin PLCC