

Main Product Characteristics:

IF	2x15A
VRRM	100V
Tj(max)	150°C
Vf(typ)	0.64V



SSTS30100CT



SSTS30100CTF

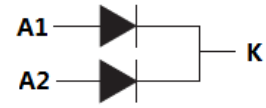

Schematic Diagram

Features and Benefits:

- High Junction Temperature
- High ESD Protection
- High Forward & Reverse Surge capability



Description:

Schottky Barrier Rectifier designed for high frequency switch model power supplies such as adaptors and DC/DC converters; this product special design for high forward and reverse surge capability

Absolute Rating:

Symbol	Characterizes	Value	Unit
VRRM	Peak Repetitive Reverse Voltage	100	V
VR(RMS)	RMS Reverse Voltage	70	V
IF(AV)	Average Forward Current	Per diode	15
		Per device	30
IFSM	Non Repetitive Surge Forward Current(tp=8.3ms sinusoidal)	200	A
IRRM	Peak Repetitive Reverse Surge Current(Tp=2us)	0.5	A
TJ	Maximum operation Junction Temperature Range	-55~150	°C
Tstg	Storage Temperature Range	-55~150	°C

Thermal Resistance

Symbol	Characterizes	Value	Unit
RθJC	Maximum Thermal Resistance Junction To	2.3	°C/W
RθJC	Case(per leg)	5.3	°C/W

Electrical Characterizes @TA=25°C unless otherwise specified

Symbol	Characterizes	Min	Typ	Max	Unit	Test Condition
VR	Reverse Breakdown Voltage	100			V	IR=0.5mA
VF	Forward Voltage Drop		0.5		V	IF=5A, TJ=25°C
			0.55		V	IF=7.5A, TJ=25°C
			0.61		V	IF=10A, TJ=25°C
			0.7	0.8	V	IF=15A, TJ=25°C
			0.45		V	IF=5A, TJ=125°C
			0.52		V	IF=7.5A, TJ=125°C
			0.57		V	IF=10A, TJ=125°C
IR	Leakage Current			0.1	mA	VR=100V, TJ=25°C
				20		VR=100V, TJ=125°C

I-V Curves:

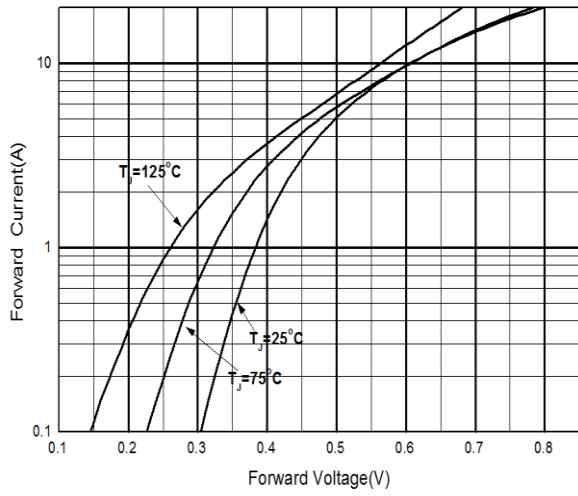

Figure 1: Typical Forward Characteristics

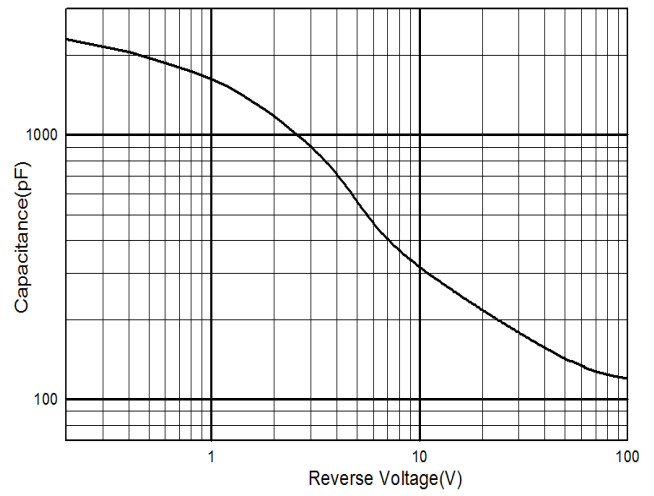

Figure 2: Typical Capacitance Characteristics

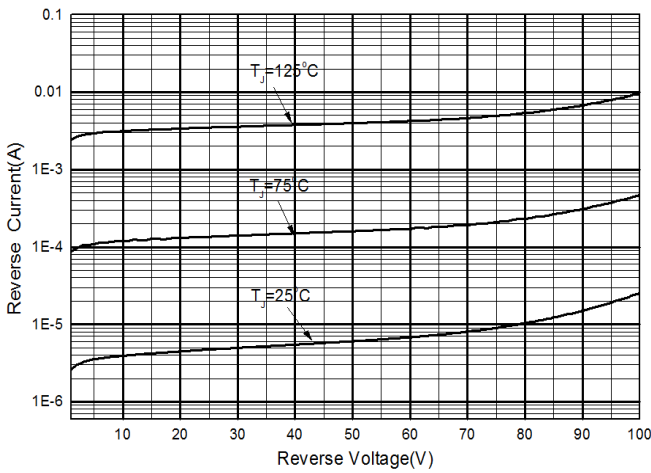

Figure 3: Typical Reverse Characteristics

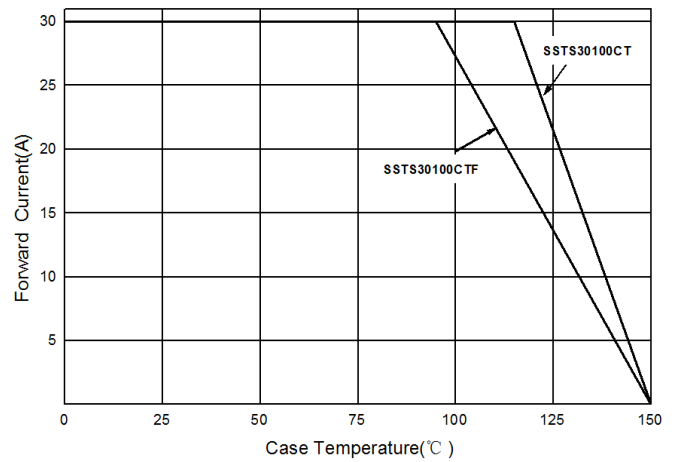
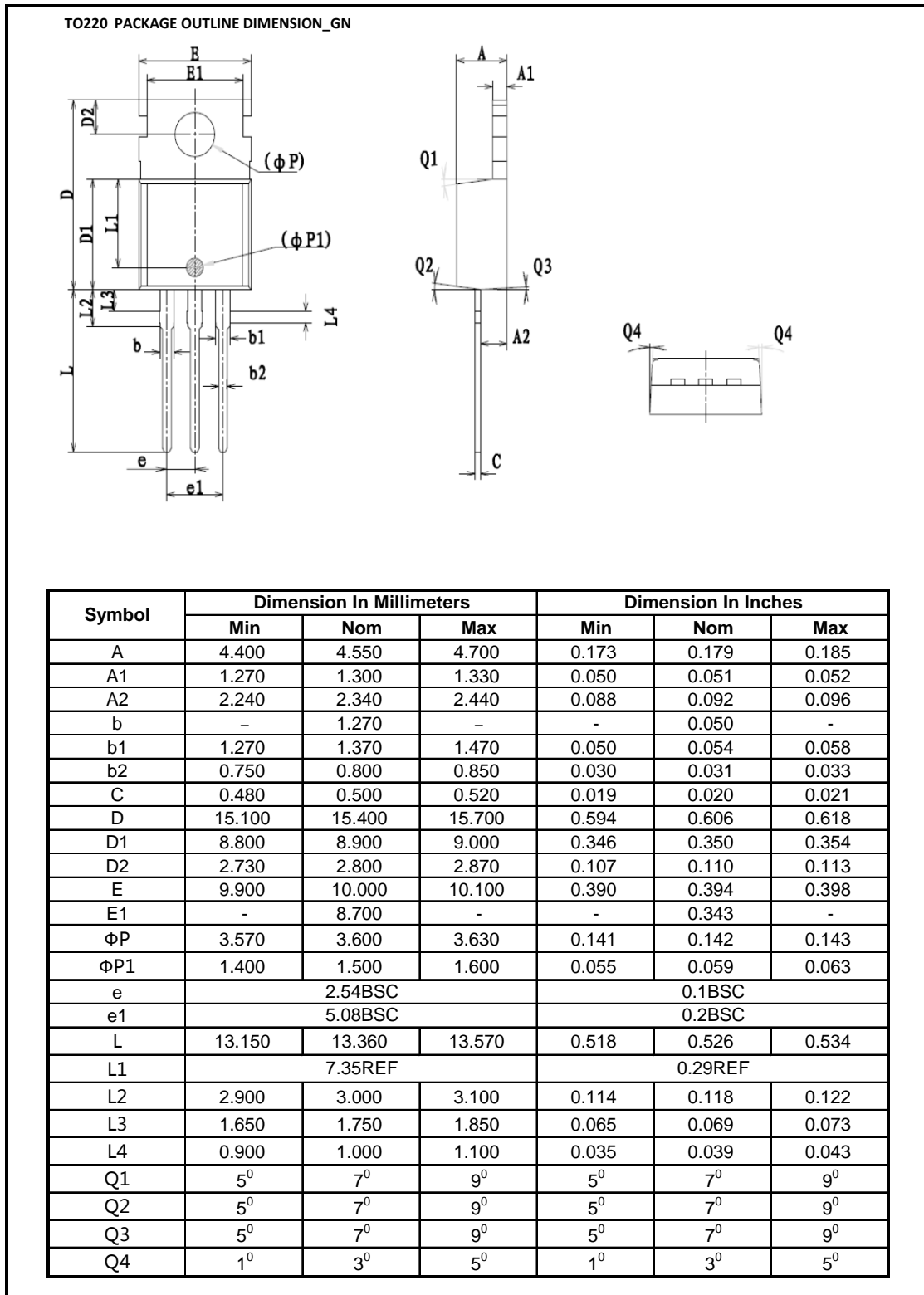
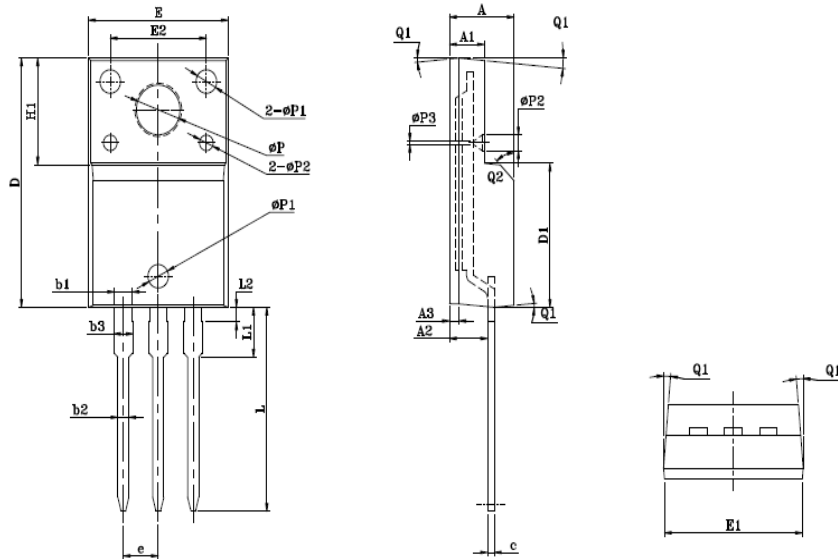

Figure 4: Forward Current Derating Curve

Mechanical Data:

TO220F PACKAGE OUTLINE DIMENSION_GN

Symbol	Dimension In Millimeters			Dimension In Inches		
	Min	Nom	Max	Min	Nom	Max
E	9.960	10.160	10.360	0.392	0.400	0.408
E1	9.840	10.040	10.240	0.387	0.395	0.403
E2	6.800	7.000	7.200	0.268	0.276	0.283
A	4.600	4.700	4.800	0.181	0.185	0.189
A1	2.440	2.540	2.640	0.096	0.100	0.104
A2	2.660	2.760	2.860	0.105	0.109	0.113
A3	0.600	0.700	0.800	0.024	0.028	0.031
c	-	0.500	-	-	0.020	-
D	15.780	15.870	15.980	0.621	0.625	0.629
D1	8.970	9.170	9.370	0.353	0.361	0.369
H1	6.500	6.700	6.800	0.256	0.264	0.268
e	2.54BSC			0.10BSC		
φP	3.080	3.180	3.280	0.121	0.125	0.129
φP1	1.400	1.500	1.600	0.055	0.059	0.063
φP2	0.900	1.000	1.100	0.035	0.039	0.043
φP3	0.100	0.200	0.300	0.004	0.008	0.012
L	12.780	12.980	13.180	0.503	0.511	0.519
L1	2.970	3.170	3.370	0.117	0.125	0.133
L2	0.830	0.930	1.030	0.033	0.037	0.041
Q1	3°	5°	7°	3°	5°	7°
Q2	43°	45°	47°	43°	45°	47°
b1	1.180	1.280	1.380	0.046	0.050	0.054
b2	0.760	0.800	0.840	0.030	0.031	0.033
b3	-	-	1.420	-	-	0.056

Ordering and Marking Information
Device Marking: SSTS30100CT&SSTS30100CTF

Package (Available)
TO-220&TO220F
Operating Temperature Range
C : -55 to 150 °C

Devices per Unit

Package Type	Units/ Tube	Tubes/Inner Box	Units/Inner Box	Inner Boxes / Carton Box	Units/ Carton Box
TO220	50	20	1000	6	6000
TO220F	50	20	1000	6	6000

Reliability Test Program

Test Item	Conditions	Duration	Sample Size
High Temperature Reverse Bias(HTRB)	Tj=125°C to 150°C @ 80% of Max VDSS/VCES/VR	168 hours 500 hours 1000 hours	3 lots x 77 devices

ATTENTION:

- Any and all Silikron products described or contained herein do not have specifications that can handle applications that require extremely high levels of reliability, such as life-support systems, aircraft's control systems, or other applications whose failure can be reasonably expected to result in serious physical and/or material damage. Consult with your Silikron representative nearest you before using any Silikron products described or contained herein in such applications.
- Silikron assumes no responsibility for equipment failures that result from using products at values that exceed, even momentarily, rated values (such as maximum ratings, operating condition ranges, or other parameters) listed in products specifications of any and all Silikron products described or contained herein.
- Specifications of any and all Silikron products described or contained herein stipulate the performance, characteristics, and functions of the described products in the independent state, and are not guarantees of the performance, characteristics, and functions of the described products as mounted in the customer's products or equipment. To verify symptoms and states that cannot be evaluated in an independent device, the customer should always evaluate and test devices mounted in the customer's products or equipment.
- Silikron Semiconductor CO.,LTD. strives to supply high-quality high-reliability products. However, any and all semiconductor products fail with some probability. It is possible that these probabilistic failures could give rise to accidents or events that could endanger human lives, that could give rise to smoke or fire, or that could cause damage to other property. When designing equipment, adopt safety measures so that these kinds of accidents or events cannot occur. Such measures include but are not limited to protective circuits and error prevention circuits for safe design, redundant design, and structural design.
- In the event that any or all Silikron products(including technical data, services) described or contained herein are controlled under any of applicable local export control laws and regulations, such products must not be exported without obtaining the export license from the authorities concerned in accordance with the above law.
- No part of this publication may be reproduced or transmitted in any form or by any means, electronic or mechanical, including photocopying and recording, or any information storage or retrieval system, or otherwise, without the prior written permission of Silikron Semiconductor CO.,LTD.
- Information (including circuit diagrams and circuit parameters) herein is for example only ; it is not guaranteed for volume production. Silikron believes information herein is accurate and reliable, but no guarantees are made or implied regarding its use or any infringements of intellectual property rights or other rights of third parties.
- Any and all information described or contained herein are subject to change without notice due to product/technology improvement, etc. When designing equipment, refer to the "Delivery Specification" for the Silikron product that you intend to use.
- This catalog provides information as of Dec, 2008. Specifications and information herein are subject to change without notice.

Customer Service**Worldwide Sales and Service:****Sales@silikron.com****Technical Support:****Technical@silikron.com****Suzhou Silikron Semiconductor Corp.****11A, 428 Xinglong Street, Suzhou Industrial Park, P.R.China****TEL: (86-512) 62560688****FAX: (86-512) 65160705****E-mail: Sales@silikron.com**