

TENTATIVE

All information in this technical data sheet is tentative
and subject to change without notice.

10.4"VGA

TECHNICAL SPECIFICATION

AA104VC02

mitsubishi / MDTI

Date: Mar.13,'03

CONTENTS

No.	Item	Page
--	COVER	1
--	CONTENTS	2
1	OVERVIEW	3
2	ABSOLUTE MAXIMUM RATINGS	4
3	ELECTRICAL CHARACTERISTICS	4, 5, 6
4	INTERFACE PIN CONNECTION	7
5	INTERFACE TIMING	8, 9, 10
6	BLOCK DIAGRAM	11
7	MECHANICAL SPECIFICATION	12, 13, 14
8	OPTICAL CHARACTERISTICS	15, 16
9	RELIABILITY TEST CONDITION	17
10	HANDLING PRECAUTIONS FOR TFT-LCD MODULE	18, 19, 20

1. OVERVIEW

AA104VC02 is 10.4" color TFT-LCD (Thin Film Transistor Liquid Crystal Display) module composed of LCD panel, driver ICs, control circuit, and backlight unit.

By applying 6 bit digital data 640×480 , 260K-color images are displayed on the 10.4" diagonal screen. Input power voltage is single 3.3 / 5.0V for LCD driving. Both 3.3V-CMOS and 5.0V-CMOS level voltage are acceptable for logic input voltage.

Inverter for backlight is not included in this module. General specifications are summarized in the following table:

ITEM	SPECIFICATION
Display Area (mm)	211.2(H) \times 158.4 (V) (10.39-inch diagonal)
Number of Dots	640 \times 3 (H) \times 480 (V)
Pixel Pitch (mm)	0.33 (H) \times 0.33 (V)
Color Pixel Arrangement	RGB vertical stripe
Display Mode	normally white
Number of Color	260K
Wide Viewing Angle Technology	Optical compensation film
Optimum Viewing Angle(Contrast ratio)	6 o'clock
Brightness (cd/m ²)	380
Module Size (mm)	243.0 (W) \times 181.6 (H) \times 12.2 (D)
Module Mass (g)	(530)
Backlight Unit	CCFL, 2-tubes, replaceable
Surface Treatment	Anti-glare and hard-coating 3H

Sign"()" is preliminary value. Characteristic value without any note is typical value.

The LCD product described in this specification is designed and manufactured for the standard use in OA equipment and consumer products, such as computers, communication equipment, industrial robots, AV equipment and so on.

Do not use the LCD product for the equipment that require the extreme high level of reliability, such as aerospace applications, submarine cables, nuclear power control systems and medical or other equipment for life support.

MDTI assumes no responsibility for any damage resulting from the use of the LCD product in disregard of the conditions and handling precautions in this specification.

If customers intend to use the LCD product for the above items or other no standard items, please contact our sales persons in advance.

2. ABSOLUTE MAXIMUM RATINGS

ITEM	SYMBOL	MIN.	MAX.	UNIT
Power Supply Voltage for LCD	VCC	-0.3	6.5	V
Logic Input Voltage	VI	0	6.5	V
Lamp Voltage	VL	0	TBD	Vrms
Lamp Current	IL	0	TBD	mArms
Lamp Frequency	FL	TBD	TBD	kHz
Operation Temperature Note 1,2)	T _{op}	0	(60)	°C
Storage Temperature Note 2)	T _{stg}	-20	(70)	°C

[Note]

1) Display panel surface

2) Top, T_{stg} ≤ 40°C : 90%RH max. without condensation

Top, T_{stg} > 40°C : Absolute humidity shall be less than the value of 90%RH at 40°C without condensation

3. ELECTRICAL CHARACTERISTICS

(1) TFT- LCD

Ambient Temperature : Ta = 25°C

ITEM		SYMBOL	MIN.	TYP.	MAX.	UNIT	Remarks
Power Supply Voltage for LCD	3.3V powered	VCC	3.0	3.3	3.6	V	A)
	5.0V powered	VCC	4.75	5.0	5.25	V	A)
Power Supply Current for LCD	3.3V powered	ICC	-	(250)	(380)	mA	VCC=3.3V ^{B)}
	5.0V powered	ICC	-	(160)	(280)	mA	VCC=5.0V ^{B)}
Permissive Input Ripple Voltage		VRP	-	-	100	mVp-p	VCC = +3.3V/5.0V
Logic Input Voltage	High	VIH	2.0	-	5.25	V	
	Low	VIL	0	-	0.8	V	

(2) Backlight

Ta=25°C

ITEM		SYMBOL	MIN.	TYP.	MAX.	UNIT	Remarks
Lamp Voltage		VL	--	TBD	--	Vrms	IL=6.0mArms
Lamp Current		IL	3.0	6.0	7.0	mArms	*1), *5)
Lamp Frequency		FL	TBD	--	TBD	kHz	*2)
Starting Lamp Voltage	Ta=25°C	VS	TBD	--	--	Vrms	
	Ta=0°C		TBD	--	--	Vrms	
Lamp Life Time	IL=3.0mA	LT	50000	50000	--	h	*3), *4)
	IL=6.0mA		50000	50000	--	h	
	IL=7.0mA		30000	40000	--	h	

*1) Lamp Current measurement method (The current meter is inserted in low voltage line.)

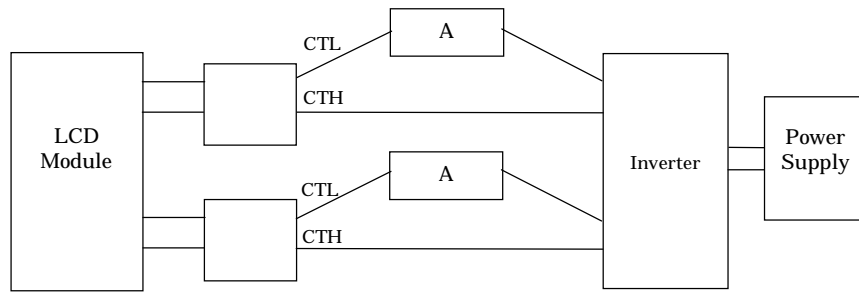

*2) Lamp frequency of inverter may produce interference with horizontal synchronous frequency, and this may cause horizontal beat on the display. Therefore, please adjust lamp frequency, and keep inverter as far from module as possible or use electronic shielding between inverter and module to avoid the interference.

*3) Lamp life time is defined as the time either when the brightness becomes 50% of the initial value, or when the starting lamp voltage does not meet the value specified in this table.

*4) The life time of the backlight depends on the ambient temperature. The life time will decrease under low/high temperature.

*5) Please use the inverter which has symmetrical current wave form as follows,

The degree of unbalance: less than 10%

The ratio of wave height: less than $\sqrt{2} \pm 10\%$

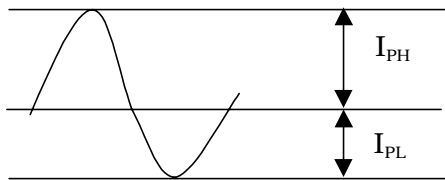

I_{PH} : High side peak

I_{PL} : Low side peak

The degree of unbalance = $|I_{PH} - I_{PL}| / I_{rms} \times 100(\%)$
 The ratio of wave height = $I_{PH}(\text{or } I_{PL}) / I_{rms}$

CURRENT WAVE FORM

[Note]

A) Power and signals sequence:

- $t1 \leq 10 \text{ ms}$
- $0 < t2 \leq 50 \text{ ms}$
- $0 < t3 \leq 50 \text{ ms}$
- $400 \text{ ms} \leq t4$
- $200 \text{ ms} \leq t5$
- $0 \leq t6$

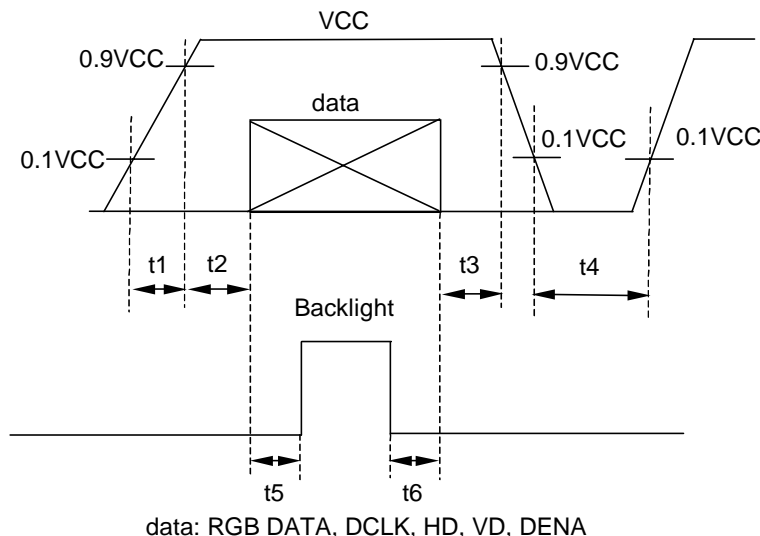

data: RGB DATA, DCLK, HD, VD, DENA

VCC-dip conditions:

(a) 3.3 V powered

- 1) When $2.6\text{ V} \leq VCC < 3.0\text{ V}$, $t_d \leq 10\text{ ms}$
- 2) When $VCC < 2.6\text{ V}$

VCC-dip conditions should also follow the power and signals sequence.

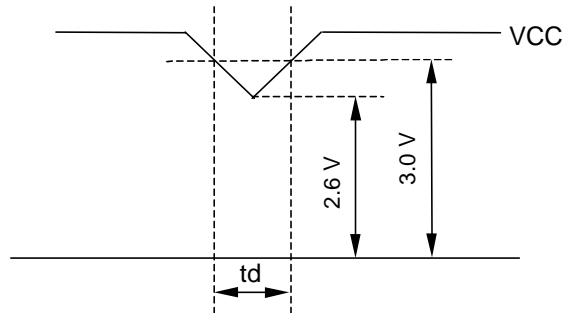

(b) 5.0V powered

- 1) When $3.6\text{ V} \leq VCC < 4.5\text{ V}$, $t_d \leq 10\text{ ms}$
- 2) When $VCC < 3.6\text{ V}$

VCC-dip conditions should also follow the power and signals sequence.

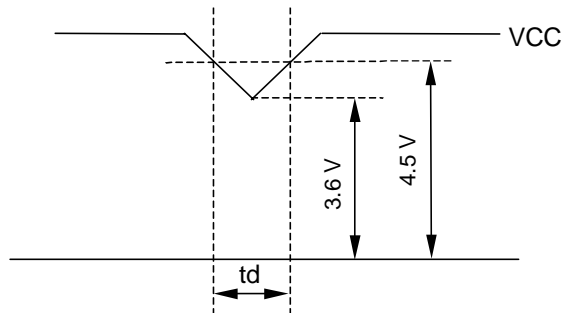

B) Typical current condition:

64- gray- bar-pattern

480 line mode

$VCC = + 3.3 / 5.0\text{ V}$, $f_H=31.6\text{kHz}$, $f_V=60\text{Hz}$, $f_{CLK}= 25\text{MHz}$

4. INTERFACE PIN CONNECTION

CN 1(INTERFACE SIGNAL)

Used connector: DF9B-31P-1V(Hirose)

Corresponding connector: DF9-31S-1V(Hirose)

Pin No.	Symbol	Function
1	GND	
2	DCLK	Clock signal for sampling catch data signal
3	HD	Horizontal sync signal
4	VD	Vertical sync signal
5	GND	
6	R0	Red data signal(LSB)
7	R1	Red data signal
8	R2	Red data signal
9	R3	Red data signal
10	R4	Red data signal
11	R5	Red data signal(MSB)
12	GND	
13	G0	Green data signal(LSB)
14	G1	Green data signal
15	G2	Green data signal
16	G3	Green data signal
17	G4	Green data signal
18	G5	Green data signal(MSB)
19	GND	
20	B0	Blue data signal(LSB)
21	B1	Blue data signal
22	B2	Blue data signal
23	B3	Blue data signal
24	B4	Blue data signal
25	B5	Blue data signal(MSB)
26	GND	
27	DENA	Data enable signal(to settle the viewing area)
28	VCC	3.3 / 5.0 V Power Supply
29	VCC	3.3 / 5.0 V Power Supply
30	TEST	This pin should be open. Test signal output for only internal test use.
31	SC	Scan direction Control.(GND or Open:Normal, High:Reverse)

*1) The shielding case is connected with GND

*2) See: Timing Chart(P9)

CN 2 , CN 3 (BACKLIGHT)

Backlight-side connector: BHR-02(8.0)VS-1N(JST)

Inverter-side connector: SM02(8.0)B-BHS(JST)

Pin No.	Symbol	Function
1	CTH	VBLH (High Voltage)
3	CTL	VBLH (Low Voltage)

[Note]

VBLH-VBLL=VL

5. INTERFACE TIMING

(1) Timing Specifications

ITEM		SYMBOL	MIN.	TYP.	MAX.	UNIT
DCLK *1) *4)	Frequency	f _{CLK}	--	25	29	MHz
	Period	t _{CLK}	34.5	40	--	ns
	Low Width	t _{WCL}	12	--	--	ns
	High Width	t _{WCH}	12	--	--	ns
DATA *1) (R,G,B,DENA HD, VD)	Set up time	t _{DS}	5	--	--	ns
	Hold time	t _{DH}	5	--	--	ns
DENA *3)	Horizontal Active Time	t _{HA}	640	640	640	t _{CLK}
	Horizontal Front Porch	t _{HFP}	10	16	--	t _{CLK}
	Horizontal Back Porch	t _{HBP}	2	144	--	t _{CLK}
	Vertical Active Time	t _{VA}	480	480	480	t _H
	Vertical Front Porch	t _{VFP}	1	12	--	t _H
	Vertical Back Porch	t _{VBP}	2	33	--	t _H
HD *2)*4)	Frequency	f _H	27	31.6	38	kHz
	Period	t _H	26.3	31.6	37.0	μs
	Low Width	t _{WHL}	5	96	--	t _{CLK}
VD *2)	Frequency	f _V	55	60	70	Hz
	Period	t _V	14.3	16.7	18.2	ms
	Low Width	t _{WVL}	3	--	--	t _H

[Note]

- *1) DATA is latched at fall edge of DCLK in this specification.
- *2) Polarities of HD and VD are negative in this specification.
- *3) DENA (Data Enable) should always be positive polarity as shown in the timing specification.
- *4) DCLK should appear during all invalid period, and HD should appear during invalid period of frame cycle.

(2) Timing Chart

a. Pixel Timing Chart

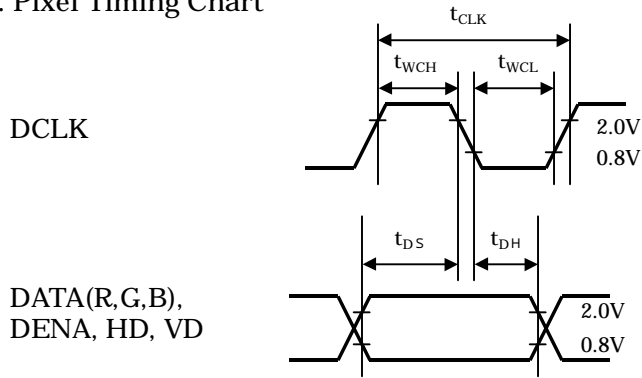

b. Horizontal Timing Chart

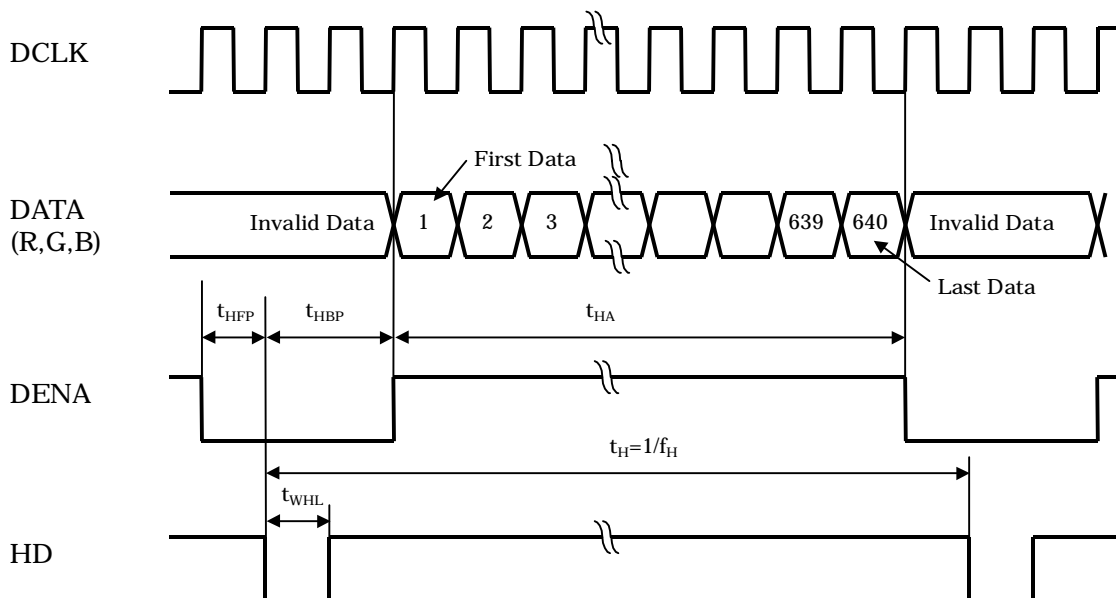

c. Vertical Timing Chart

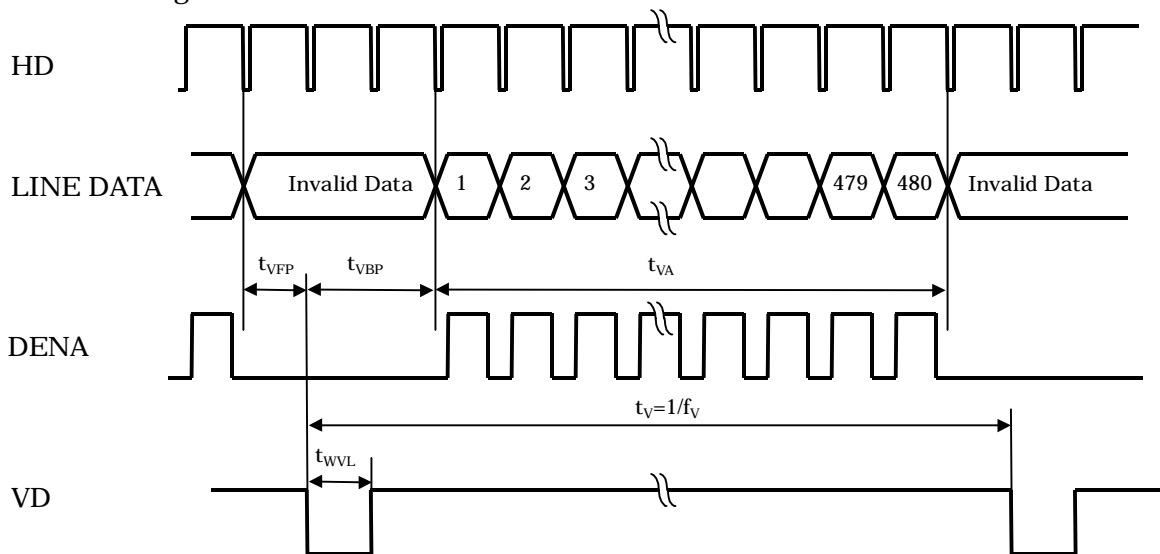

(3) Color Data Assignment

COLOR	INPUT DATA	R DATA						G DATA						B DATA					
		R5	R4	R3	R2	R1	R0	G5	G4	G3	G2	G1	G0	B5	B4	B3	B2	B1	B0
		MSB					LSB	MSB					LSB	MSB					LSB
BASIC COLOR	BLACK	0	0	0	0	0	0	0	0	0	0	0	0	0	0	0	0	0	0
	RED(63)	1	1	1	1	1	1	0	0	0	0	0	0	0	0	0	0	0	0
	GREEN(63)	0	0	0	0	0	0	1	1	1	1	1	1	0	0	0	0	0	0
	BLUE(63)	0	0	0	0	0	0	0	0	0	0	0	0	1	1	1	1	1	1
	CYAN	0	0	0	0	0	0	1	1	1	1	1	1	1	1	1	1	1	1
	MAGENTA	1	1	1	1	1	1	0	0	0	0	0	0	1	1	1	1	1	1
	YELLOW	1	1	1	1	1	1	1	1	1	1	1	1	0	0	0	0	0	0
	WHITE	1	1	1	1	1	1	1	1	1	1	1	1	1	1	1	1	1	1
RED	RED(0)	0	0	0	0	0	0	0	0	0	0	0	0	0	0	0	0	0	0
	RED (1)	0	0	0	0	0	1	0	0	0	0	0	0	0	0	0	0	0	0
	RED(2)	0	0	0	0	1	0	0	0	0	0	0	0	0	0	0	0	0	0
	RED (62)	1	1	1	1	1	0	0	0	0	0	0	0	0	0	0	0	0	0
	RED(63)	1	1	1	1	1	1	0	0	0	0	0	0	0	0	0	0	0	0
GREEN	GREEN(0)	0	0	0	0	0	0	0	0	0	0	0	0	0	0	0	0	0	0
	GREEN (1)	0	0	0	0	0	0	0	0	0	0	0	1	0	0	0	0	0	0
	GREEN(2)	0	0	0	0	0	0	0	0	0	0	1	0	0	0	0	0	0	0
	GREEN(62)	0	0	0	0	0	0	1	1	1	1	1	0	0	0	0	0	0	0
	GREEN(63)	0	0	0	0	0	0	1	1	1	1	1	1	0	0	0	0	0	0
BLUE	BLUE(0)	0	0	0	0	0	0	0	0	0	0	0	0	0	0	0	0	0	0
	BLUE(1)	0	0	0	0	0	0	0	0	0	0	0	0	0	0	0	0	0	1
	BLUE(2)	0	0	0	0	0	0	0	0	0	0	0	0	0	0	0	0	1	0
	BLUE(62)	0	0	0	0	0	0	0	0	0	0	0	0	1	1	1	1	1	0
	BLUE(63)	0	0	0	0	0	0	0	0	0	0	0	0	1	1	1	1	1	1

[Note]

- 1) Definition of gray scale
 Color (n) --- n indicates gray scale level.
 Higher n means brighter level.
- 2) Data
 1:High, 0: Low

6. BLOCK DIAGRAM

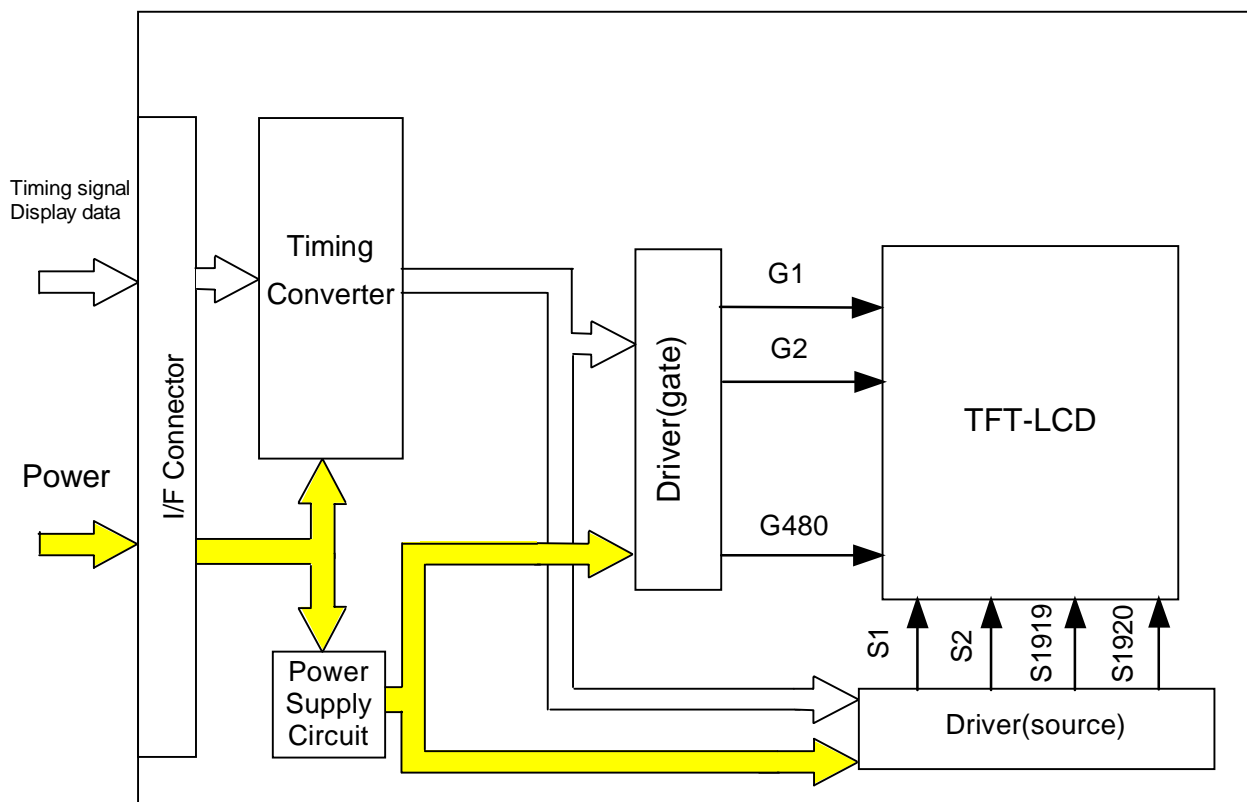

BACKLIGHT

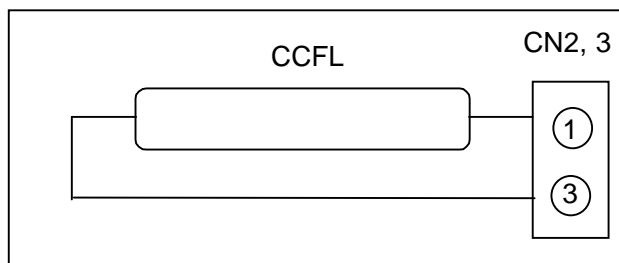

(2) Rear Side

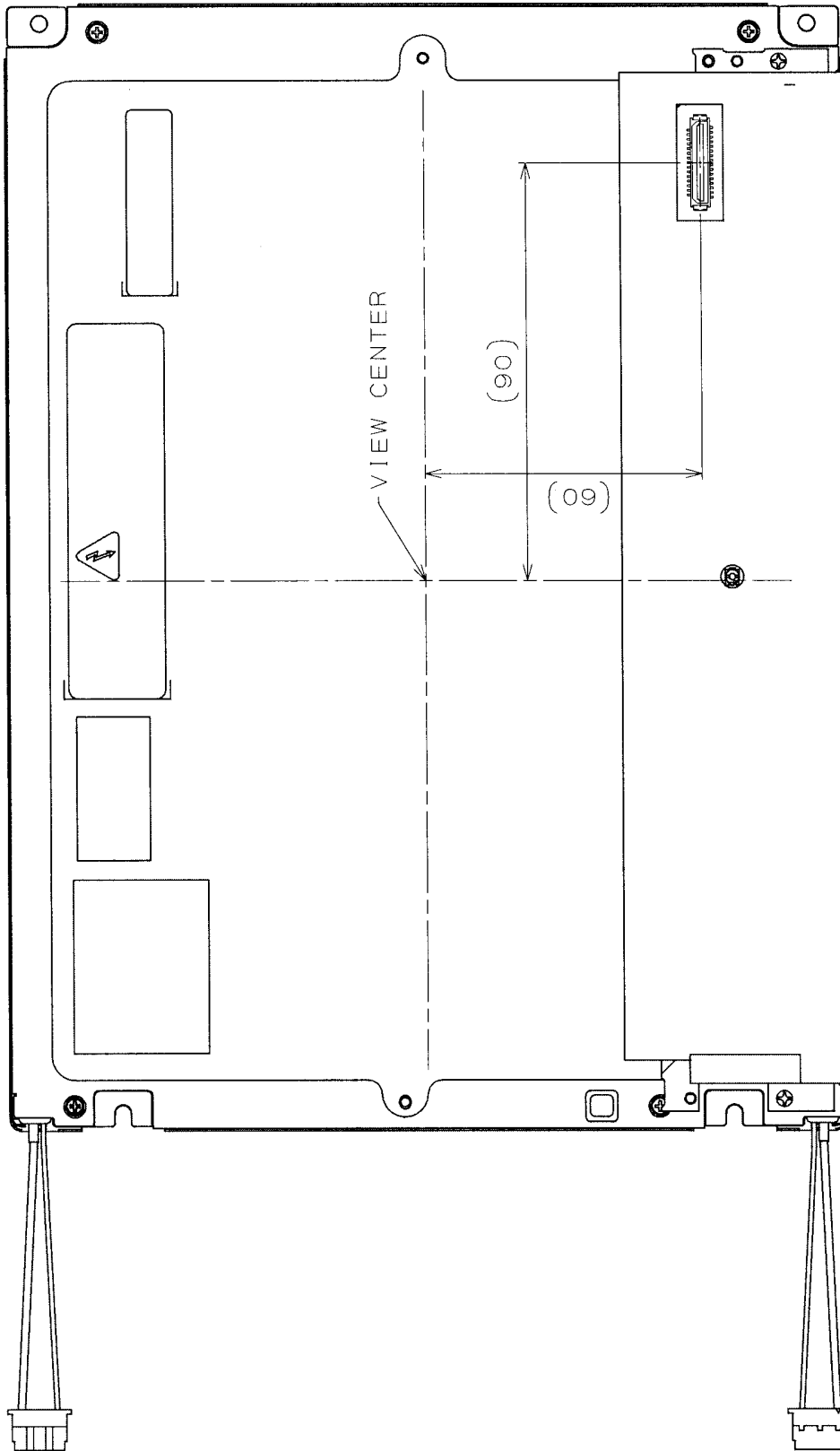

(Unit:mm)
Tolerance is $\pm 0.5\text{mm}$ unless noted
Except for thickness of PET film

[Note]

We recommend you referring to the detailed drawing for your design.
Please contact our company sales representative when you need the detailed drawing.

(3) Scanning direction

SC : GND or Open

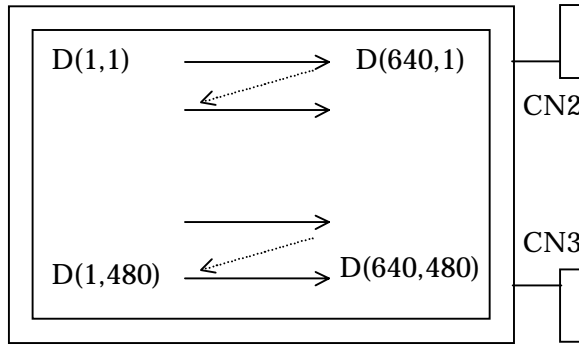

SC : High

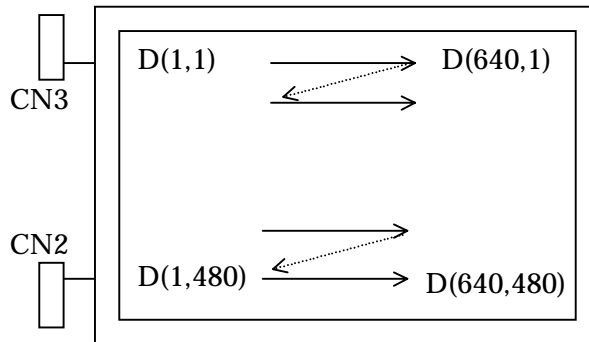

8. OPTICAL CHARACTERISTICS

Ta=25°C, VCC=3.3 / 5.0 V, Input Signals: Typ. Values shown in Section 5

ITEM		SYMBOL	CONDITION	MIN.	TYP.	MAX.	UNIT	Remarks
Contrast Ratio		CR	$\theta = \phi = 0^\circ$	150	300	--	--	*1)*3)
Luminance		Lw	$\theta = \phi = 0^\circ$	300	380	--	cd/m ²	*2)*3)
Response Time		tr	$\theta = \phi = 0^\circ$	--	TBD	--	ms	*3)*4)
		tf	$\theta = \phi = 0^\circ$	--	TBD	--	ms	*3)*4)
Viewing Angle	Horizontal	ϕ	CR \geq 10	--	-60~60	--	°	*3)
	Vertical	θ		--	-50~40	--	°	*3)
Image Sticking		tis	2 h	--	--	2	s	*5)
Color Coordinates	Red	Rx	$\theta = \phi = 0^\circ$	--	TBD	--	--	*3)
		Ry		--	TBD	--		
	Green	Gx		--	TBD	--		
		Gy		--	TBD	--		
	Blue	Bx		--	TBD	--		
		By		--	TBD	--		
	White	Wx		--	TBD	--		
		Wy		--	TBD	--		

[Note]

These items are measured using CS1000(MINOLTA) for color coordinates, EZContrast(ELDIM) for viewing angle and CS1000 or BM-5A(TOPCON) for others under the dark room condition (no ambient light) after more than 30 minutes from turning on the lamp unless noted.

*1) Definition of Contrast Ratio

CR=ON(White) Luminance / OFF(Black) Luminance: average of 5 points shown in a figure below

*2) Definition of Luminance

Lw= ON (White) Luminance: average of 5 points shown in a figure below

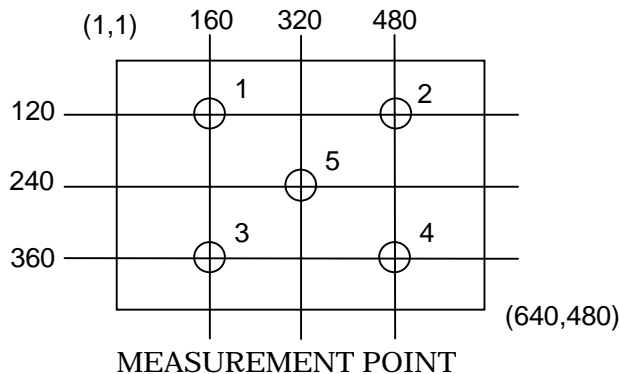

*3) Definition of Viewing Angle(θ , ϕ)

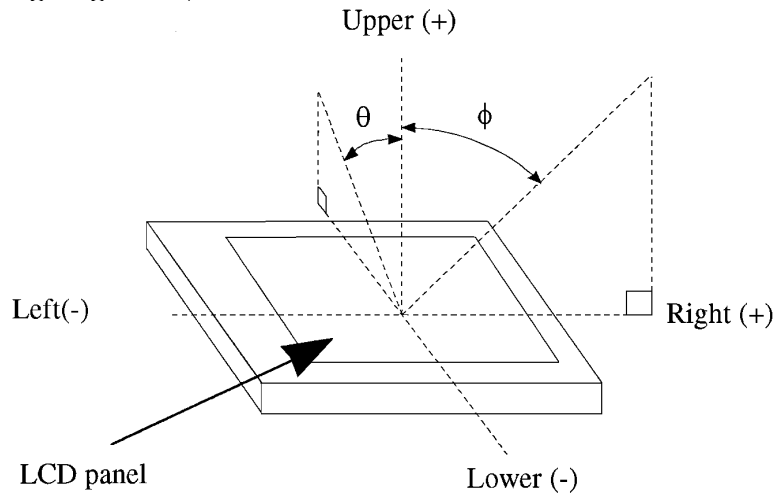

*4) Definition of Response Time

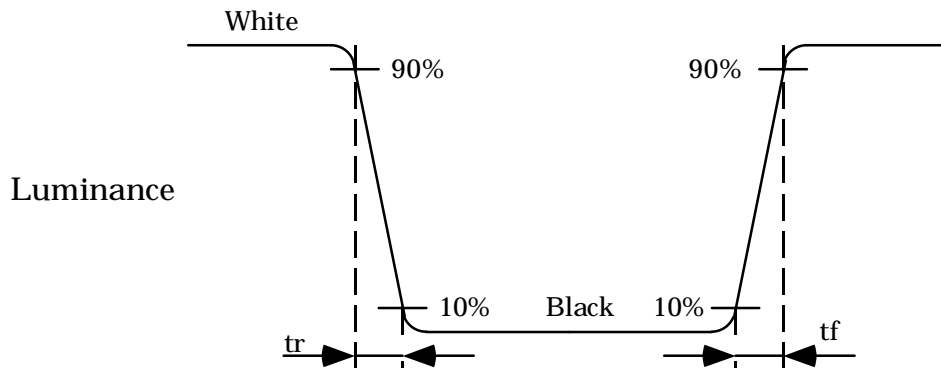

*5) Image Sticking

Continuously display the test pattern shown in the figure below for two-hours. Then display a completely white screen. The previous image shall not persist more than two seconds at 25°C.

TEST PATTERN FOR IMAGE STICKING TEST

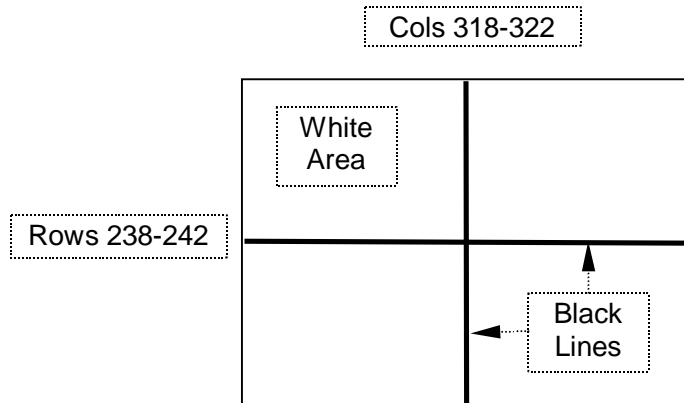

9. RELIABILITY TEST CONDITION

(1) Temperature and Humidity

TEST ITEM	CONDITIONS
HIGH TEMPERATURE HIGH HUMIDITY OPERATION	40°C, 90%RH, 240 h
HIGH TEMPERATURE STORAGE	70°C, 96 h
LOW TEMPERATURE STORAGE	-20°C, 96 h
THERMAL SHOCK(NON-OPERATION)	BETWEEN -20°C (1h) and 70°C(1h), 5 CYCLES

(2) Shock & Vibration

ITEM	CONDITIONS
SHOCK (NON-OPERATION)	Shock level: 1470m/s ² (150G) Waveform: half sinusoidal wave, 2ms Number of shocks: one shock input in each direction of three mutually perpendicular axis for a total of six shock inputs
VIBRATION (NON-OPERATION)	Vibration level: 9.8m/s ² (1.0G) Waveform: sinusoidal Frequency range: 5 to 500Hz Frequency sweep rate: 0.5 octave /min Duration: one sweep from 5 to 500 Hz in each of three mutually perpendicular axis(total 3 hours)

(3) Judgment standard

The judgment of the above tests should be made as follow:

Pass: Normal display image with no obvious non-uniformity and no line defect.

Partial transformation of the module parts should be ignored.

Fail: No display image, obvious non-uniformity, or line defects.

10. HANDLING PRECAUTIONS FOR TFT-LCD MODULE

Please pay attention to the followings in handling TFT-LCD products;

(1) ASSEMBLY PRECAUTION

- a. Please use the mounting hole on the module in installing and do not bending or wrenching LCD in assembling. And please do not drop, bend or twist LCD module in handling.
- b. Please design display housing in accordance with the following guide lines.
 - (a) Housing case must be designed carefully so as not to put stresses on LCD all sides and not to wrench module. The stresses may cause non-uniformity even if there is no non-uniformity statically.
 - (b) Keep sufficient clearance between LCD module back surface and housing when the LCD module is mounted. Approximately 1.0mm of the clearance in the design is recommended taking into account the tolerance of LCD module thickness and mounting structure height on the housing.
 - (c) When some parts, such as, FPC cable and ferrite plate, are installed underneath the LCD module, still sufficient clearance is required, such as 0.5mm. This clearance is, especially, to be reconsidered when the additional parts are implemented for EMI countermeasure.
 - (d) Design the inverter location and connector position carefully so as not to give stress to lamp cable, or not to interface the LCD module by the lamp cable.
 - (e) Keep sufficient clearance between LCD module and the others parts, such as inverter and speaker so as not to interface the LCD module. Approximately 1.0mm of the clearance in the design is recommended.
- c. Please do not push or scratch LCD panel surface with anything hard. And do not soil LCD panel surface by touching with bare hands. (Polarizer film, surface of LCD panel is easy to be flawed.)
- d. Please do not press any parts on the rear side such as source TCP, gate TCP, control circuit board and FPCs during handling LCD module. If pressing rear part is unavoidable, handle the LCD module with care not to damage them.
- e. Please wipe off LCD panel surface with absorbent cotton or soft cloth in case of it being soiled.
- f. Please wipe off drops of adhesives like saliva and water on LCD panel surface immediately. They might damage to cause panel surface variation and color change.
- g. Please do not take a LCD module to pieces and reconstruct it. Resolving and reconstructing modules may cause them not to work well.
- h. Please do not touch metal frames with bare hands and soiled gloves. A color change of the metal frames can happen during a long preservation of soiled LCD modules.
- i. Please handle metal frame carefully to avoid getting hurt because edge of metal frame is very sharp.

- j. Please pay attention to handling lead wire of backlight so that it is not tugged in connecting with inverter.
- k. Be sure to connect the cables and the connectors correctly.
- l. Please connect the metal frame of LCD module to GND in order to minimize the effect of external noise and EMI.

(2) OPERATING PRECAUTIONS

- a. Please be sure to turn off the power supply before connecting and disconnecting signal input cable.
- b. Please do not change variable resistance settings in LCD module. They are adjusted to the most suitable value. If they are changed, it might happen LCD does not satisfy the characteristics specification.
- c. LCD backlight takes longer time to become stable of radiation characteristics in low temperature than in room temperature.
- d. The interface signal speed is very high. Please pay attention to transmission line design and other high speed signal precautions to satisfy signal specification.
- e. A condensation might happen on the surface and inside of LCD module in case of sudden change of ambient temperature.
- f. Please pay attention not to display the same pattern for very long time. Image might stick on LCD. Even if image sticking happens, it may disappear as the operation time proceeds.
- g. Please obey the same safe instructions as ones being prepared for ordinary electronic products.

(3) PRECAUTIONS WITH ELECTROSTATICS

- a. This LCD module use CMOS-IC on circuit board and TFT-LCD panel, and so it is easy to be affected by electrostatics. Please be careful with electrostatics by the way of your body connecting to the ground and so on.
- b. Please remove protection film very slowly from the surface of LCD module to prevent from electrostatics occurrence.

(4) STORAGE PRECAUTIONS

- a. Please do not leave the LCDs in the environment of high humidity and high temperature such as 60°C90%RH.
- b. Please do not leave the LCDs in the environment of low temperature; below -20°C.

(5) SAFETY PRECAUTIONS

- a. When you waste damaged or unnecessary LCDs, it is recommended to crush LCDs into pieces and wash them off with solvents such as acetone and ethanol, which should later be burned.
- b. If any liquid leaks out of a damaged glass cell and comes in contact with the hands, wash off thoroughly with soap and water.
- c. Be sure to turn off the power supply when inserting or disconnecting the cable.
- d. Inverter should be designed carefully so as not to keep working in case of detecting over current or open circuit on the lamp.

(6) OTHERS

- a. A strong incident light into LCD panel might cause display characteristics changing inferior because of polarizer film, color filter, and other materials becoming inferior. Please do not expose LCD module direct sunlight and strong UV rays.
- b. Please pay attention to a panel side of LCD module not to contact with other materials in preserving it alone.
- c. For the packaging box, please pay attention to the followings;
 - (a) Packaging box and inner case for LCD are designed to protect the LCDs from the damage or scratching during transportation. Please do not open except picking LCDs up from the box.
 - (b) Please do not pile them up more than 5 boxes. (They are not designed so.) And please do not turn over.
 - (c) Please handle packaging box with care not to give them sudden shock and vibrations. And also please do not throw them up.
 - (d) Packaging box and inner case for LCDs are made of cardboard. So please pay attention not to get them wet. (Such like keeping them in high humidity or wet place can occur getting them wet.)