

DESCRIPTION

RM1410 consists of step-down switching regulator with PWM control. These devices include a reference voltage source, oscillation circuit, error amplifier, internal PMOS and etc.

RM1410 provides low-ripple power, high efficiency, and excellent transient characteristics. The PWM control circuit is able to vary the duty ratio linearly from 0 up to 100%. An enable function, an over current protect function and a short circuit protect function are built inside, and when OCP or SCP happens, the operation frequency will be reduced from 380KHz to 35KHz. Also, an internal compensation block is built in to minimum external component count.

With the addition of an internal P-channel Power MOS, a coil, capacitors, and a diode connected externally, these ICs can function as step-down switching regulators. They serve as ideal power supply units for portable devices when coupled with the SOP-8L mini-package, providing such outstanding features as low current consumption. Since this converter can accommodate an input voltage up to 15V, it is also suitable for the operation via an AC adapter.

FEATURES

- Input voltage: 3.6V to 15V
- Output voltage: 0.8V to V_{CC}
- Duty ratio: 0% to 100% PWM control
- Oscillation frequency: 380KHz typ
- Current limit, Enable function
- Thermal Shutdown function
- Built-in internal SW P-channel MOS
- SOP-8L Pb-Free Package
- Compatible with TD1410/MP1410

Applications

- Battery Charger Adapter
- PC Motherboard
- LCD Monitor
- Graphic Card
- DVD-Video Player
- Telecom Equipment
- ADSL Modem
- Printer and other Peripheral Equipment
- Microprocessor core supply
- Networking power supply

TYPICAL APPLICATION

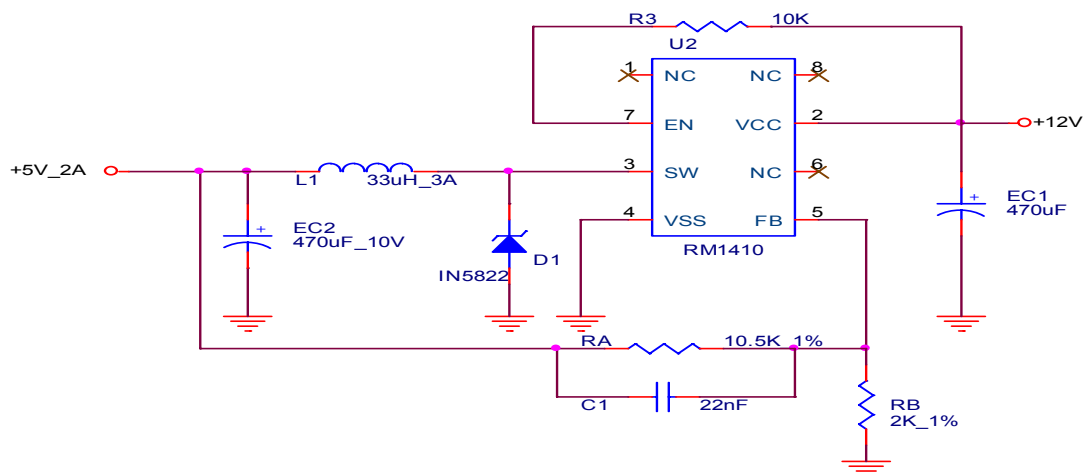

PACKAGE INFORMATION

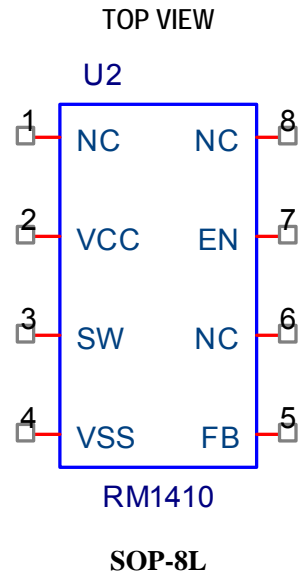

PIN FUNCTIONS

Pin	Symbol	Function Description
1,6,8	NC	Not connect.
2	Vcc	IC power supply pin
3	Output	Switch Pin. Output is the switch node that supplies power to the output. Connect external inductor/diode here. Minimize trace area at this pin to reduce EMI.
4	Vss	GND Pin.
5	FB	Feedback pin. Through an external resistor divider network, FB senses the output voltage and regulates it.
7	EN	Power-off pin H: Normal operation (Step-down operation). L: Step-down operation stopped (All circuits deactivated).

ABSOLUTE MAXIMUM RATINGS

Symbol	Parameter	Rating	Unit
V_{CC}	V_{CC} Pin Voltage	$V_{SS}-0.3$ to $V_{SS}+18$	V
V_{FB}	Feedback Pin Voltage	$V_{SS}-0.3$ to V_{CC}	V
V_{EN}	EN Pin Voltage	$V_{SS}-0.3$ to $V_{CC}+0.3$	V
V_{OUTPUT}	Switch Pin Voltage	$V_{SS}-0.3$ to $V_{CC}+0.3$	V
P_D	Power Dissipation	Internally limited	mW
T_{OPR}	Operating Temperature Range	-20 to +125	°C
T_{STG}	Storage Temperature Range	-40 to +150	°C

Caution: The absolute maximum ratings are rated values exceeding which the product could suffer physical damage. These values must therefore not be exceeded under any conditions.

ELECTRICAL CHARACTERISTICS

The specifications are applied at $T=25^{\circ}\text{C}$, $V_{CC}=12\text{V}$, unless otherwise noted.

Symbol	Parameter	Conditions	Min.	Typ.	Max.	Unit
V_{IN}	Input Voltage	-	3.6	-	15	V
V_{FB}	Feedback Voltage	$I_{OUT}=0.2\text{A}$	0.784	0.8	0.824	V
I_{FB}	Feedback Bias Current	$I_{OUT}=0.2\text{A}$	-	0.1	0.5	μA
I_{SW}	Switch Current	-	2.5	-	-	A
I_{SSS}	Current Consumption During Power Off	$V_{EN}=0\text{V}$	-	0.1	-	μA
I_Q	Quiescent Current	$V_{FB}=2\text{V}$	-	4.0	6.0	mA
$\Delta V_{OUT}/V_{OUT}$	Line Regulation	$V_{IN}=7\text{V}\sim 15\text{V}$	-	2	4	%
$\Delta V_{OUT}/V_{OUT}$	Load Regulation	$I_{OUT}=0.2$ to 2A	-	0.2	0.5	%
F_{OSC}	Oscillation Frequency	Measure waveform at SW pin	340	380	420	KHz
F_{OSC1}	Frequency of Current Limit or Short Circuit Protect	Measure waveform at SW pin	-	35	-	KHz
V_{SH}	EN Pin Input Voltage	Evaluate oscillation at SW pin	2.0	-	-	V
V_{SL}		Evaluate oscillation stop at SW pin	-	-	0.8	
I_{SH}	EN Pin Input Leakage Current	-	-	20	-	μA
I_{SL}		-	-	-10	-	μA
T_{SS}	Soft-Start Time	-	0.3	2	5	ms
R_{DSON}	Internal MOSFET R_{dson}	$V_{IN}=5\text{V}$, $V_{FB}=0\text{V}$	-	100	150	m Ω
		$V_{IN}=12\text{V}$, $V_{FB}=0\text{V}$	-	65	100	
EFFI	Efficiency	$V_{IN}=12\text{V}$, $V_{OUT}=5\text{V}$, $I_{OUT}=2\text{A}$	-	90	-	%

BLOCK DIAGRAM

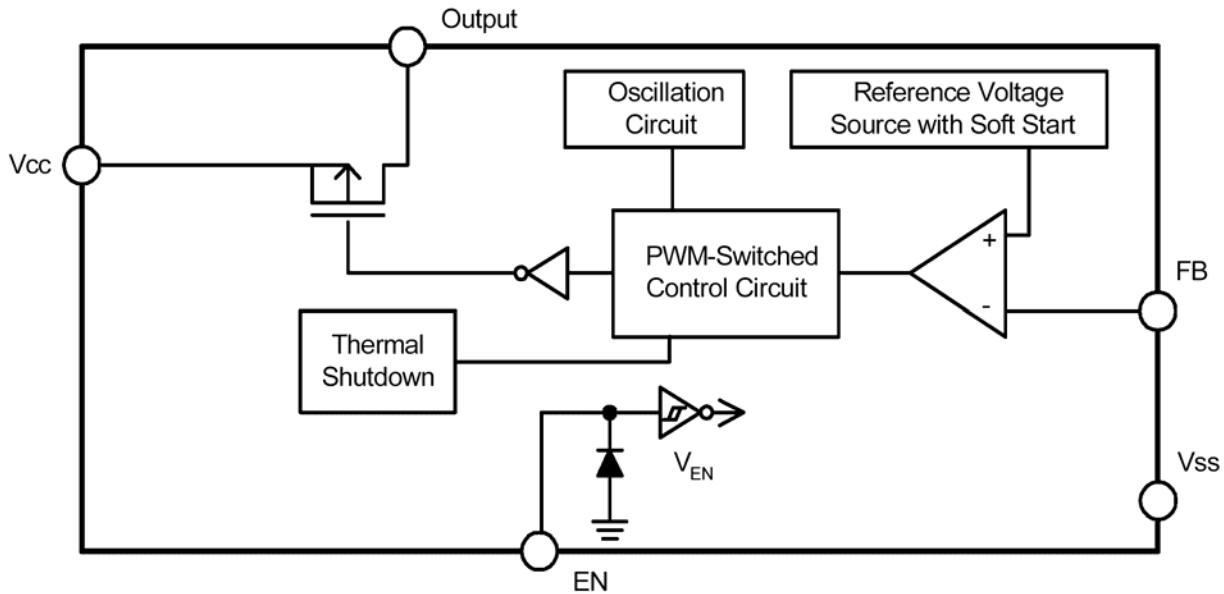

OPERATION (Refer to Block Diagram)

PWM Control

The RM1410 consists of DC/DC converters that employ a pulse-width modulation (PWM) system. In converters of the RM1410, the pulse width varies in a range from 0 to 100%, according to the load current. The ripple voltage produced by the switching can easily be removed through a filter because the switching frequency remains constant. Therefore, these converters provide a low-ripple power over broad ranges of input voltage and load current.

Pin Functions

Vcc

This is the positive input supply for the IC switching regulator. A suitable input bypass capacitor must be present at this pin to minimize voltage transients and to supply the switching currents needed by the regulator.

Vss

Circuit ground.

SW

Internal switch. The voltage at this pin switches

between $(V_{cc} - V_{DS})$ and approximately $-0.5V$, with a duty cycle of approximately V_{OUT} / V_{cc} . To minimize coupling to sensitive circuitry, the PC board copper area connected to this pin should be kept a minimum.

FB

Senses the regulated output voltage to complete the feedback loop.

EN

Allows the switching regulator circuit to be shutdown using logic level signals thus dropping the total input supply current to approximately $0.1\mu A$. Pulling this pin below a threshold voltage of approximately $0.8V$ turns the regulator down, and pulling this pin above $2V$ lets the regulator on.

Typical Operating Characteristics

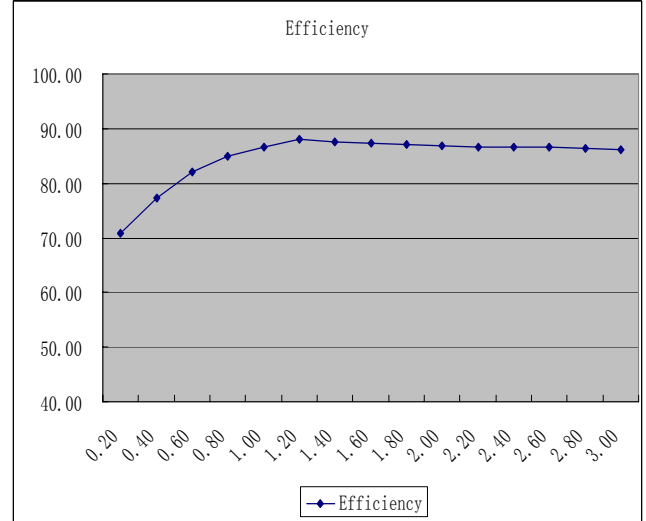
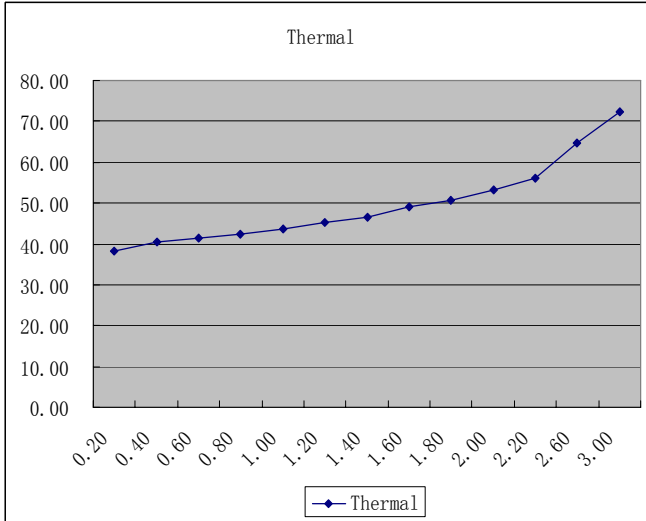

Thermal VS. Output Current
Soft-start (output current=0.5A)

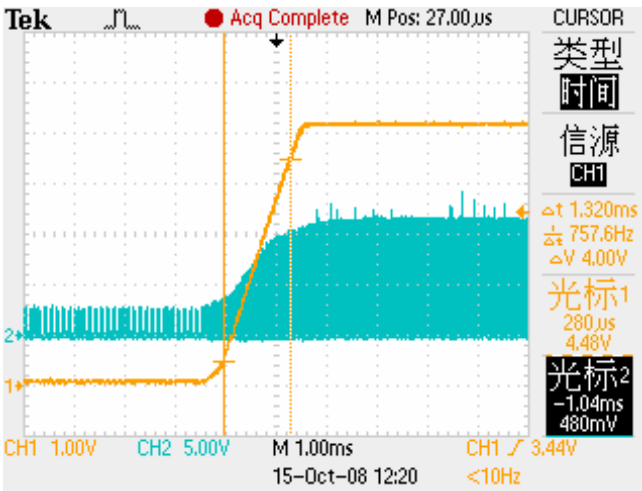

Efficiency VS. Output Current
Soft-start (output current=2A)

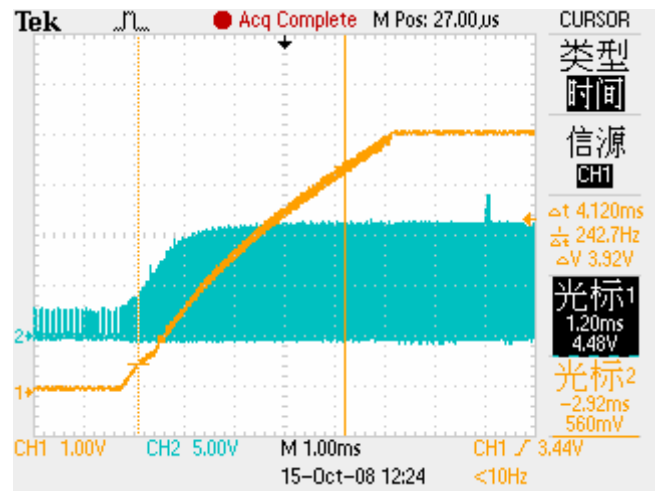

Turn off (output current=0.5A)

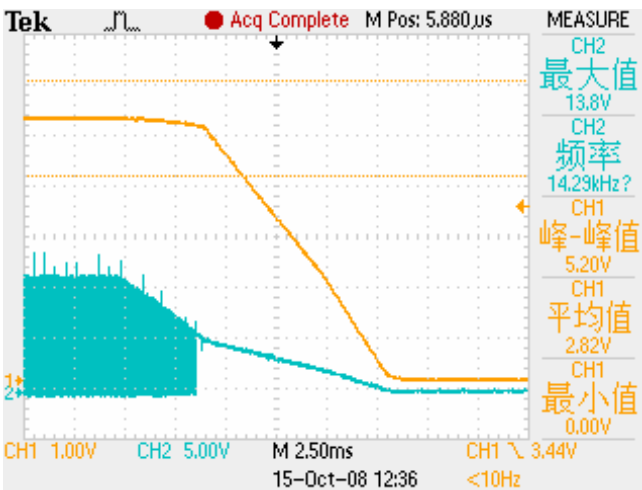

Turn off (output current=2A)

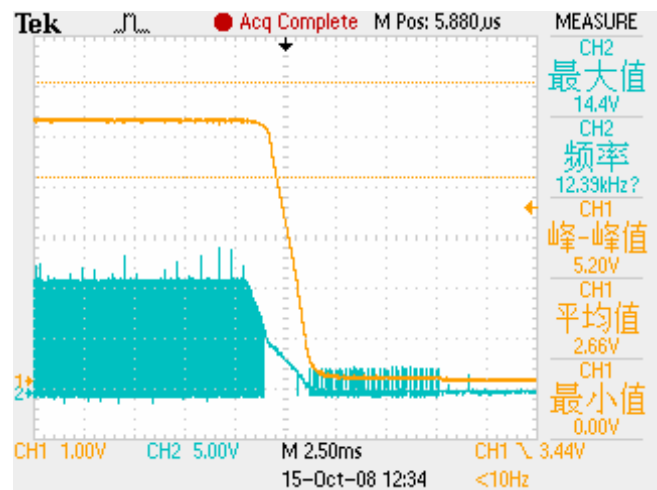

Frequency (output current=0.5A)

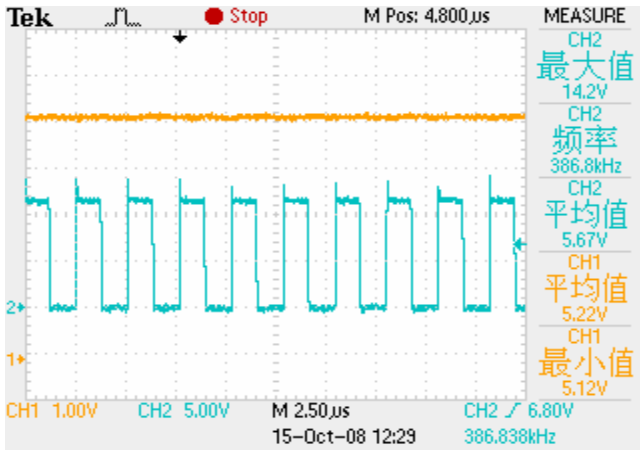

Frequency (output current=2A)

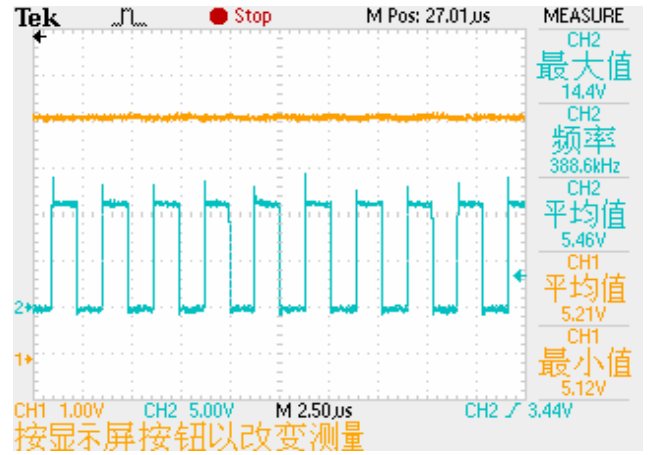

Short output protect

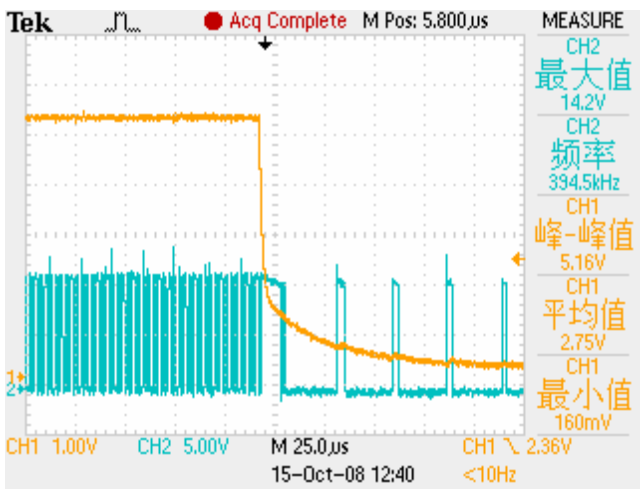

Application Information

Inductor Selection

The selection of output inductor is based on the considerations of efficiency, output power and operating frequency. Low inductance value has smaller size, but results in low efficiency, large ripple current and high efficiency, large ripple current and high output ripple voltage. Generally, an inductor and 50% of output current is appropriate.

$$V_{in} - V_{out} = L \frac{\Delta I_L}{\Delta t};$$

$$\Delta t = \frac{D}{f_s}; D = \frac{V_{out}}{V_{in}};$$

$$L = (V_{in} - V_{out}) \times \frac{V_{out}}{V_{in} \times f_s \times \Delta I_L};$$

Where:

$$\Delta t = D \times \text{Turn on time}$$

$$\Delta I_L = \text{Inductor current ripple}$$

(approximately equal 0.3 times of max output current)

Output Capacitor Selection

The selection of output capacitor depends on the output ripple voltage requirement. Practically, the output ripple voltage is a function of both

capacitance value and the equivalent series resistance. The AC impedance of output capacitor at operating frequency is quite smaller than the load impedance, so the ripple current of the inductor current flows mainly through output capacitor. The output ripple voltage is described as:

$$\Delta V_{out} = \frac{\Delta I_L}{\Delta t} \times ESL + \Delta I_L \times ESR$$

$$N = \frac{ESR_{(each)} \times \Delta I_L}{\Delta V_{out}}$$

Where:

$$\Delta V_{out} = \text{max ripple voltage in output}$$

Input Capacitor Selection

The selection of input capacitor is mainly based on its maximum ripple current capability. The RMS value of ripple current flowing through the input capacitor is described as:

$$I_{RMS} = I_{out} \times \sqrt{D \times (1 - D)}$$

The input capacitor must be capable of handling this ripple current. Sometimes, for higher efficiency the low ESR capacitor is necessary.

PACKAGE INFORMATION

Package Type: SOP-8L

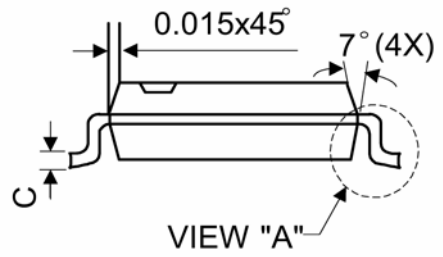
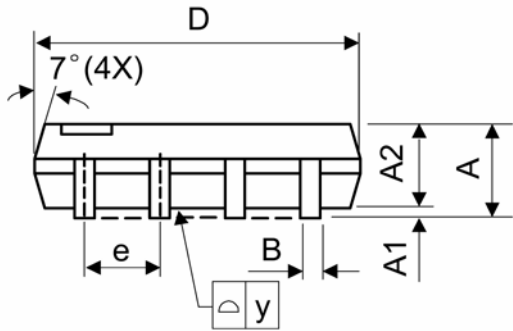
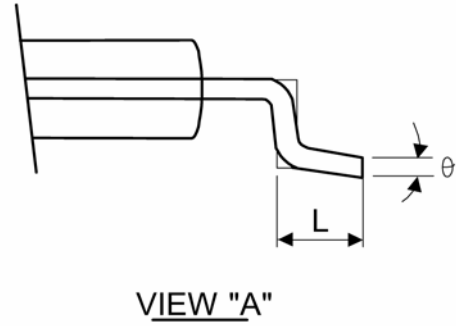
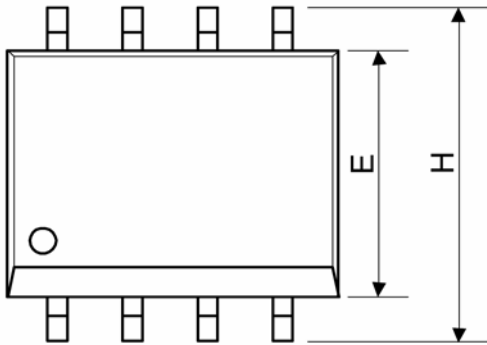

Dimensions

Symbol	Dimensions In Millimeters			Dimensions In Inches		
	Min.	Nom.	Max.	Min.	Nom.	Max.
A	1.40	1.60	1.75	0.055	0.063	0.069
A1	0.10	-	0.25	0.040	-	0.100
A2	1.30	1.45	1.50	0.051	0.057	0.059
B	0.33	0.41	0.51	0.013	0.016	0.020
C	0.19	0.20	0.25	0.0075	0.008	0.010
D	4.80	5.05	5.30	0.189	0.199	0.209
E	3.70	3.90	4.10	0.146	0.154	0.161
e	-	1.27	-	-	0.050	-
H	5.79	5.99	6.20	0.228	0.236	0.244
L	0.38	0.71	1.27	0.015	0.028	0.050
y	-	-	0.10	-	-	0.004
θ	0°	-	8°	0°	-	8°