

Data sheet	
status	Preliminary specification
date of issue	April 1991

# TDA3840

## TV IF amplifier and demodulator with TV signal identification

### FEATURES

- Low supply voltage range, from 5.0 V to 8.0 V
- Low power dissipation, 200 mW at 5 V
- High supply ripple rejection
- Wide IF bandwidth of 80 MHz
- Synchronous demodulator with low differential phase and gain
- Additional video buffer with a wide bandwidth of 10 MHz
- Video off switch
- Peak sync AGC
- Adjustable take-over point (TOP); positive AGC slope
- Switching to fast AGC dependent on TV identification
- Alignment free AFC detector with integrated phase shift
- ESD protection
- TV signal identification
- Options: tracking of reference circuit

### GENERAL DESCRIPTION

The TDA3840 is a bipolar integrated circuit for vision IF-signal processing in TV and VTRs, designed for a supply voltage range from 5.0 V to 8.0 V.

### QUICK REFERENCE DATA

SYMBOL	PARAMETER	CONDITIONS	MIN.	TYP.	MAX.	UNIT
$V_P$	supply voltage range (pin 15)		4.75	5.0	8.8	V
$I_P$	supply current (pin 15)	$V_P = 5.0$ V	–	42	–	mA
$V_{1-20(rms)}$	IF input signal for nominal video output voltage at pin 14 (RMS value)	$f = 38.9$ MHz	–	70	–	$\mu$ V
	minimum IF input signal for TV signal identification at pin 6 (RMS value)	maximum $G_V$	–	20	40	$\mu$ V
$V_O$	video output signal (pin 12)	buffered	–	2.0	–	V
$G_V$	IF voltage gain control range		–	66	–	dB
S/N	signal-to-noise ratio	$V_{1-20} = 10$ mV	55	60	–	dB
$V_B$	AFC output voltage swing		–	4.0	–	V
$S_{AFC}$	AFC steepness (pin 8)		–	2	–	$\mu$ A/kHz
RR	supply voltage ripple rejection (pin 12)		30	35	–	dB

### ORDERING INFORMATION

EXTENDED TYPE NUMBER	PACKAGE			
	PINS	PIN POSITION	MATERIAL	CODE
TDA3840	20	DIL	plastic	SOT146
TDA3840T	20	mini-pack	plastic	SO20L; SOT163A

# TV IF amplifier and demodulator with TV signal identification

## TDA3840

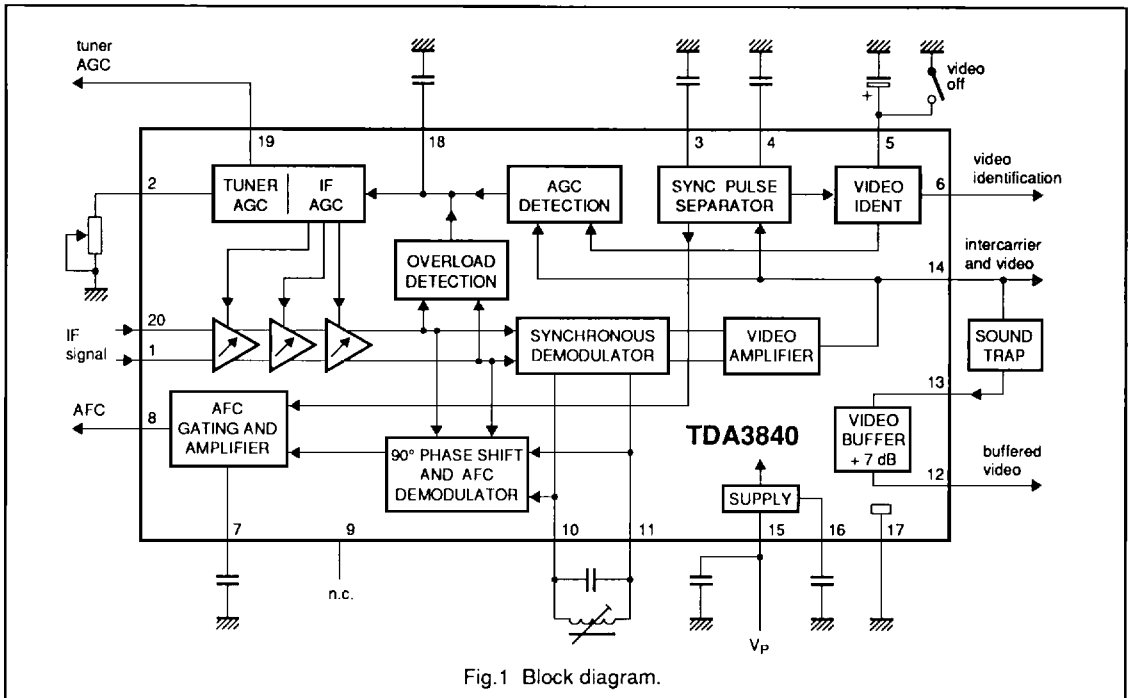

Fig.1 Block diagram.

### PIN CONFIGURATION

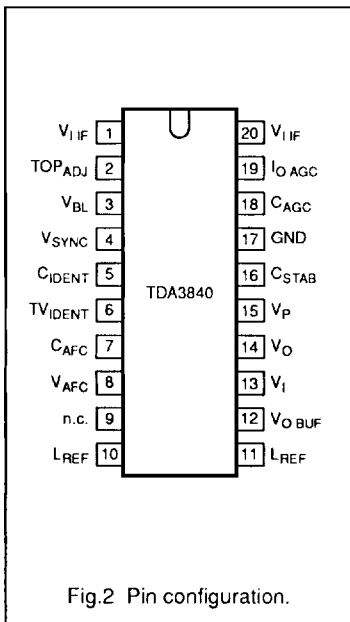

Fig.2 Pin configuration.

### PINNING

SYMBOL	PIN	DESCRIPTION
V <sub>I</sub> IF	1	IF input (balanced)
TOP <sub>ADJ</sub>	2	tuner AGC take-over point adjustment
V <sub>BL</sub>	3	black level voltage
V <sub>SYNC</sub>	4	sync pulse amplitude voltage
C <sub>IDENT</sub>	5	identification capacitor
TV <sub>IDENT</sub>	6	video identification output
C <sub>AFC</sub>	7	AFC capacitor
V <sub>AFC</sub>	8	AFC output signal
n.c.	9	not connected
L <sub>REF</sub>	10	LC reference tuned circuit
L <sub>REF</sub>	11	LC reference tuned circuit
V <sub>O</sub> BUF	12	buffered video output signal
V <sub>I</sub>	13	video input signal for buffer
V <sub>O</sub>	14	video output signal with intercarrier signal
V <sub>P</sub>	15	supply voltage
C <sub>STAB</sub>	16	supply voltage stabilization
GND	17	ground
C <sub>AGC</sub>	18	AGC capacitor
I <sub>O</sub> AGC	19	tuner AGC output signal
V <sub>I</sub> IF	20	IF input (balanced)

# TV IF amplifier and demodulator with TV signal identification

## TDA3840

### FUNCTIONAL DESCRIPTION

The complete circuit consists of the following functional blocks as shown in Fig.1:

1. 3-stage gain controlled IF amplifier
2. Overload detector
3. Reference amplifier
4. Carrier signal reference limiter
5. Video demodulator
6. Video amplifier
7. Video buffer amplifier
8. AGC detector
9. IF and tuner AGC (with adjustable TOP)
10. Sync pulse separator
11. Video identification
12. 90° phase shift and AFC demodulator
13. AFC gating, AFC amplifier and AFC switch
14. Voltage stabilizer

#### 1. 3-stage gain controlled IF amplifier (pins 1 and 20)

The vision IF amplifier consists of three AC-coupled differential amplifier stages. Gain control is achieved by current divider stages. The emitter feedback resistors are optimized for low noise and signal handling capability.

#### 2. Overload detector

The overload detector is fed from the output of the third IF amplifier. As soon as the IF voltage exceeds the overload threshold in the detector, its output current reduces the IF amplification by discharging the AGC capacitor.

#### 3. Reference amplifier

For passive video carrier regeneration an integrated differential amplifier with resistive load allows capacitive coupling of the resonant circuit for notch and tracking functions.

#### 4. Carrier signal reference limiter

A limiter stage after the reference amplifier eliminates amplitude modulation. Its output is fed to the video demodulator.

#### 5. Video demodulator

The video demodulator receives both the limited reference carrier signal and the IF signal. The video signal can also be switched off.

#### 6. Video amplifier

The video amplifier is an operational amplifier with internal feedback and wide bandwidth.

#### 7. Video buffer amplifier

The video buffer amplifier is an operational amplifier with internal feedback, wide bandwidth and frequency compensation; gain and input impedance are adapted to operate with a ceramic sound trap. The load for the sound trap is an integrated resistive divider.

#### 8. AGC detector

The peak sync AGC detector generates a fast current pulse to discharge the AGC capacitor (gain reduction). This minimizes the video signal distortion.

To filter out the sound carrier the video signal is fed through low pass filters. After the low pass filters the video signal with attenuated sound carrier, is fed to the AGC detector. The charging current of the AGC capacitor is optimized for minimum distortion of the video signal. With positive modulation the charging current is very low and consequently the AGC time constant is large. When the video identification circuit does not detect a video signal, the charging current is increased.

#### 9. IF and tuner AGC

The voltage on the AGC capacitor is used to control the gain of the three IF amplifier stages and to supply the tuner AGC current (open-collector). The tuner AGC TOP potentiometer at pin 2 adjusts the IF signal level from the tuner. To stabilize the IF output voltage of the tuner, IF slip (= variation of IF gain over the total tuner range) is kept at a minimum.

#### 10. Sync pulse separator

The sync pulse separator supplies two internally-used pulses using the bandwidth limited video signal. These are the composite sync for the AFC detector and the vertical sync for the video identification output. The bandwidth is limited to reduce the noise and increase the identification sensitivity.

#### 11. Video identification

An analog integrator monitors the duty cycle of the vertical sync pulses to identify the video signal. The integrator output is fed to a window comparator which has an open collector output stage to provide the video ident signal. The complete circuit operates in combination with the sync separator and is optimized for high sensitivity.

#### 12. 90° phase shift and AFC demodulator

The AFC demodulator needs a 90° phase-shifted carrier. The output of the carrier signal reference limiter is fed to an active 90° phase-shift circuit. The 90° (lead) phase-shifted carrier and the IF signal are fed to the AFC demodulator. The demodulated signal and the IF signal are fed to the AFC gating stage.

# TV IF amplifier and demodulator with TV signal identification

## TDA3840

### 13. AFC gating, AFC amplifier and AFC switch

With negative modulated video IF signals the output of the AFC detector is gated by composite sync pulses to prevent video modulation on the AFC output. The gated signal is integrated by an AFC capacitor. The AFC amplifier converts the capacitor voltage to an AFC current (open collector sink/source output). The AFC function can be externally

switched off for test purposes. For high-performance signal handling the AFC signal can be used to track the resonant circuit as shown in Fig.11.

### 14. Voltage stabilizer

An integrated bandgap voltage stabilizer generates an internal supply voltage of 4 V. A decoupling capacitor reduces noise and supply voltage ripple.

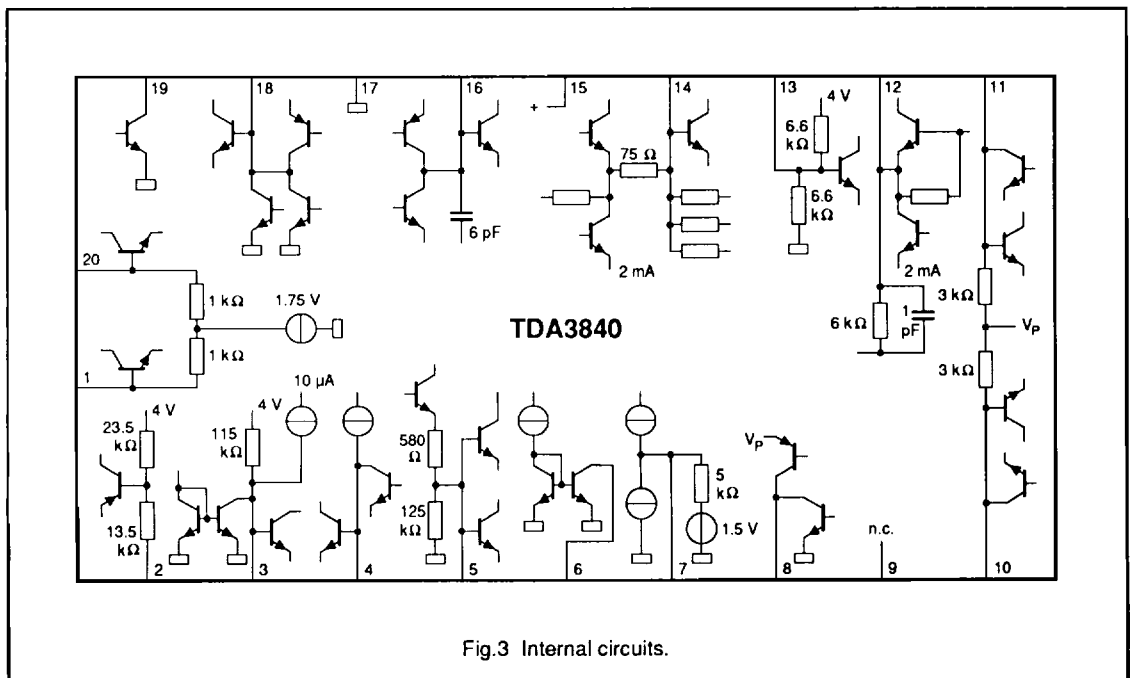

Fig.3 Internal circuits.

# TV IF amplifier and demodulator with TV signal identification

## TDA3840

### LIMITING VALUES

In accordance with the Absolute Maximum System (IEC 134)

SYMBOL	PARAMETER	MIN.	MAX.	UNIT
$V_P$	supply voltage at pin 15: SOT146	–	8.8	V
	SOT163A	–	6.0	V
$V_{19}$	tuner AGC voltage	–	13.2	V
$V_8$	permissible voltage at AFC output	–	$V_P$	V
$I_{15}$	supply current	–	55	mA
$T_{stg}$	storage temperature range	–25	+ 150	°C
$T_{amb}$	operating ambient temperature range	0	+ 70	°C
$V_{ESD}$	ESD sensitivity	–	± 300	V

### CHARACTERISTICS

$V_P = 5\text{ V}$  and  $T_{amb} = 25\text{ °C}$ ;  $f_{VC} = 38.9\text{ MHz}$ ; all voltages are measured to GND (pin 17); measured in test circuit of Fig.4.; unless otherwise specified.

SYMBOL	PARAMETER	CONDITIONS	MIN.	TYP.	MAX.	UNIT
$V_P$	supply voltage range (pin 15)	DIL-package	4.75	5.0	8.8	V
		SO-package	4.75	5.0	6.0	V
$I_P$	supply current (pin 15)	$V_P = 5.0\text{ V}$	–	42	–	mA
RR	ripple rejection (pin 12)		30	35	–	dB
<b>IF amplifier</b>						
B	bandwidth	–3 dB	–	80	–	MHz
$R_i$	input resistance (pins 1 and 20)		–	2	–	k $\Omega$
$C_i$	input capacitance (pins 1 and 20)		–	1.5	–	pF
$V_{1-20(rms)}$	IF input signal (RMS value)	video output –1 dB	–	70	–	$\mu\text{V}$
	maximum IF input signal	minimum $G_V$ ; note 1	100	–	–	mV
$G_V$	gain control range		63	66	–	dB

# TV IF amplifier and demodulator with TV signal identification

## TDA3840

SYMBOL	PARAMETER	CONDITIONS	MIN.	TYP.	MAX.	UNIT
<b>IF AGC</b>						
I <sub>18</sub>	leakage current AGC capacitor		–	–	1	μA
	charging current AGC capacitor	with video identification	–	13	–	μA
	charging current AGC capacitor	without video identification	–	35	–	μA
I <sub>18M</sub>	discharging peak current capacitor		–	2	–	mA
t <sub>1</sub>	response time of IF input signal change	50 dB increasing step	–	1	–	ms
		50 dB decreasing step	–	150	–	ms
<b>Tuner AGC (note 2)</b>						
V <sub>1-20(rms)</sub>	lower IF input signal for starting point of tuner take-over; see Fig.5 (RMS value)	R <sub>2</sub> = 22 kΩ	–	–	1	mV
	upper IF input signal for starting point of tuner take-over; see Fig.5 (RMS value)	R <sub>2</sub> = 0 Ω	50	–	–	mV
	TOP variation	60 K temperature range	–	2	3	dB
I <sub>19</sub>	tuner AGC output current	V <sub>19</sub> = 0.5 V	1	2	–	mA
<b>Synchronous demodulator and video amplifier (note 3)</b>						
V <sub>14</sub>	composite video output signal		0.9	1.0	1.1	V
	sync level voltage		–	1.5	–	V
	zero carrier level voltage		–	2.6	–	V
I <sub>14</sub>	output current	DC and AC	–	–	± 1.0	mA
R <sub>14</sub>	output resistance		–	75	–	Ω
B	video bandwidth at –1 dB (pin 14)	C <sub>load</sub> ≤ 20 pF	7	8	–	MHz
V <sub>14</sub>	upper video clipping level		–	3.6	–	V
	lower video clipping level		–	0.3	–	V
<b>Buffered video output signal (see Fig.6)</b>						
G	gain of video buffer		6.5	7.0	–	dB
V <sub>12</sub>	sync level clamping voltage		–	1.35	–	V
	upper video clipping level		–	4.25	–	V
	lower video clipping level		–	0.3	–	V
I <sub>12</sub>	output current	DC and AC	–	–	± 1.0	mA
R <sub>12</sub>	output resistance		–	–	10	Ω
B	video bandwidth at –1 dB (pin 12)	C <sub>load</sub> ≤ 20 pF	–	10	–	MHz
R <sub>1</sub>	input resistance (pin 13)		–	3.3	–	kΩ
C <sub>1</sub>	input capacitance (pin 13)		–	2	–	pF

# TV IF amplifier and demodulator with TV signal identification

## TDA3840

SYMBOL	PARAMETER	CONDITIONS	MIN.	TYP.	MAX.	UNIT
<b>Overall video performance (see Fig.6)</b>						
$V_o$	video output signal (pin 12)	negative modulation; note 3	–	2	–	V
B	video bandwidth at –2 dB (pin 12)	$C_{load} \leq 20$ pF	7	8	–	MHz
S/N	signal-to-noise ratio (see Fig.7)	$V_{1-20} = 10$ mV; note 4	55	60	–	dB
$\alpha_1$	intermodulation for blue (note 5)	$f = 1.1$ MHz $f = 3.3$ MHz	56 62	58 –	– –	dB dB
$\alpha_2$	intermodulation for yellow (note 5)	$f = 1.1$ MHz $f = 3.3$ MHz	53 60	56 –	– –	dB dB
$\alpha_3$	signal harmonic suppression		–	26	–	dB
$V_5$	video switch off voltage	note 6	–	–	1	V
$\alpha_4$	attenuation of video signal (pin 14)	video signal switched off	50	60	–	dB
$\Delta G$	differential gain	EBU test line 330	–	2	–	%
$\Delta \Phi$	differential phase	EBU test line 330	–	2	–	deg
$\Delta V/V$	variation of video output signal (pin 14)	gain control 50 dB; $V_{1-20(rms)} = 0.3$ to 100 mV	–	–	0.5	dB
$V_{res1}$	residual vision carrier (pin 12)		–	1	–	mV
$V_{res2}$	residual second harmonic of the vision carrier (pin 12)		–	1	–	mV
<b>Video identification</b>						
$V_{1-20(rms)}$	minimum IF input signal for TV identification at pin 14 (RMS value)	maximum $G_v$	–	20	40	$\mu$ V
$V_6$	video identification voltage (signal unidentified)	$V_{1-20} = < 40 \mu V_{rms}$ $I_6 = 0.5$ mA	–	–	0.4	V
	video identification voltage (signal identified)	$V_{1-20} = \geq 40 \mu V_{rms}$ $I_6 = -1 \mu A$	4.5	–	–	V
$T_{sync}/T_{field}$	vertical pulse duty cycle		4.5	8	16	$\times 10^{-3}$
C/N	carrier-to-noise ratio (pin 1 and pin 20)	note 7	–	8	–	dB
$I_5$	allowed leakage current		–	–	3	$\mu$ A
$\alpha_5$	sync pulse suppression for correct TV signal identification		–	–	70	%
$t_d$	delay time of mute output signal		–	100	150	ms

# TV IF amplifier and demodulator with TV signal identification

## TDA3840

SYMBOL	PARAMETER	CONDITIONS	MIN.	TYP.	MAX.	UNIT
<b>AFC</b> (see Fig.9 and Fig.10); note 8						
$I_8$	AFC source current output		0.16	0.19	0.22	mA
	AFC sink current output		0.16	0.19	0.22	mA
$V_8$	upper output voltage		4.3	–	4.7	V
	lower output voltage		0.3	–	0.7	V
S	control steepness	$Q_B = 40$ ; $V_{1-20(rms)} = 10 \text{ mV}$	–	2	–	$\mu\text{A/kHz}$
$I_7$	leakage current at AFC gating		–	–	$\pm 1$	$\mu\text{A}$

### Notes to the characteristics

- The video signal is still gain-controlled,  $V_{14(p-p)} = 1 \text{ V}$ , but intermodulation figures are degraded.
- The starting point of tuner AGC can be adjusted by the resistor at pin 2. Fig.5 shows the AGC characteristic.
- IF input signals are RMS values measured at TOP sync (standard B/G) and with a vision carrier of 38.9 MHz (see Fig.4). The IF input signal is fed from 50  $\Omega$  via a 1:1 transformer, DSB, to pins 1 and 20. With a 10 mV<sub>RMS</sub> IF input signal, the residual vision carrier is:  
= 10 % for white (standard B/G).
- In the test circuit of Fig.4, measured and weighted according to CCIR Recommendation 567:

$$S/N = \frac{V_{14} \text{ (black to white)}}{V_{14} \text{ noise (RMS, black)}}$$

- Intermodulation figures are defined as follows:

$$\alpha_1 = 20 \times \log \frac{V_o \text{ at 4.4 MHz}}{V_o \text{ at 1.1 MHz}} + 3.6 \text{ dB}$$

and

$$\alpha_2 = 20 \times \log \frac{V_o \text{ at 4.4 MHz}}{V_o \text{ at 3.3 MHz}}$$

- When  $V_5 < 1 \text{ V}$  (short-circuited identification capacitor at pin 5) the video output signal at pin 14 is switched off.  $V_{14}$  shifts to "zero carrier level" ("ultra white" (2.6V) for negative modulation). During normal operation the capacitor at pin 5 should not be loaded ( $|I_5| \leq 3 \mu\text{A}$ ).
- The C/N at the IF input (pins 1 and 20) for TV identification is defined as the RMS sync level of the vision IF signal input, relative to the RMS value of a superimposed white noise signal, with a bandwidth limited to 5 MHz.

- The values for the AFC measurements depend on the  $Q_B$  of the reference circuit at pins 10 and 11. The internal phase shift is matched to a vision carrier of 38.9 MHz. The AFC function can be switched off for test purposes when pin 7 is connected to ground ( $V_7 = 0 \text{ V}$ ).



# TV IF amplifier and demodulator with TV signal identification

## TDA3840

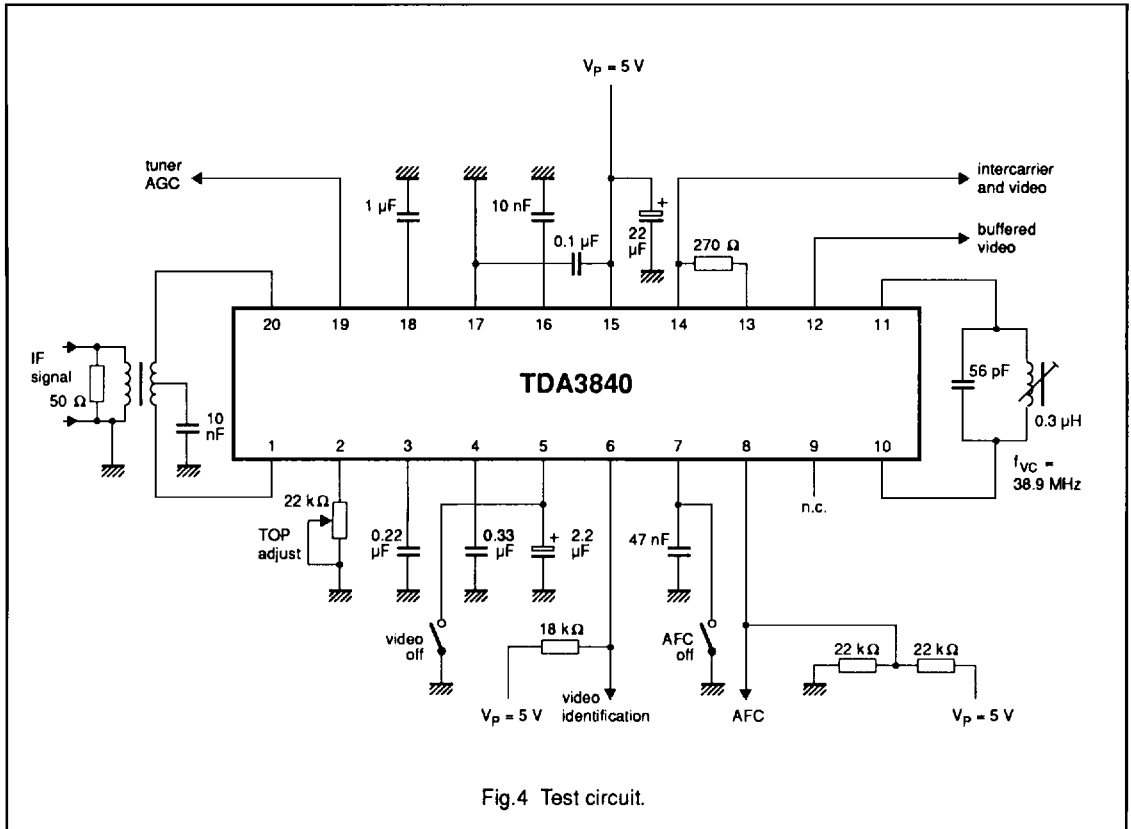

Fig.4 Test circuit.

# TV IF amplifier and demodulator with TV signal identification

## TDA3840

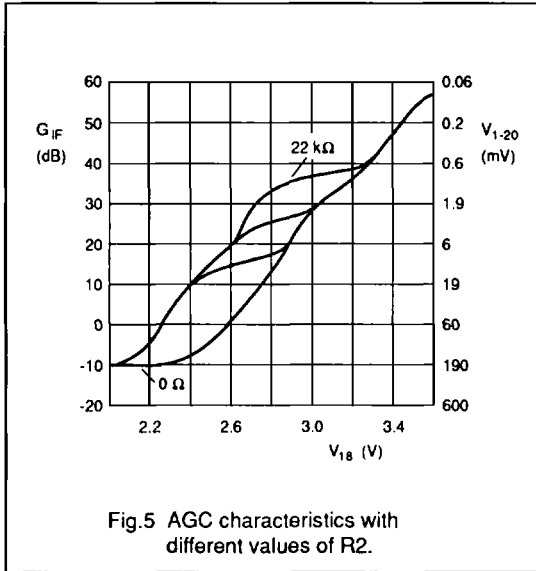

Fig.5 AGC characteristics with different values of R2.

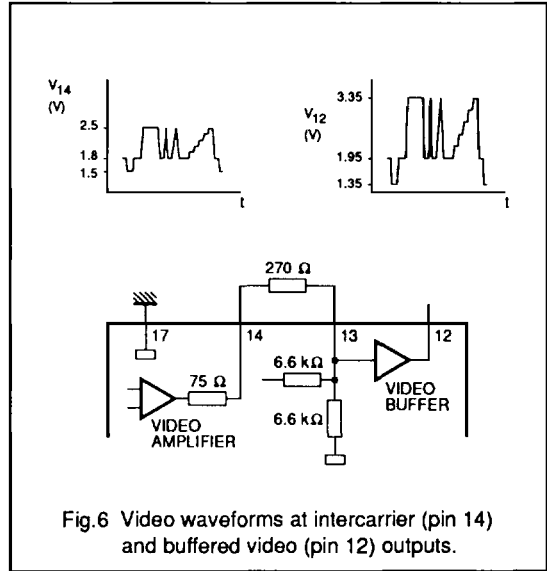

Fig.6 Video waveforms at intercarrier (pin 14) and buffered video (pin 12) outputs.

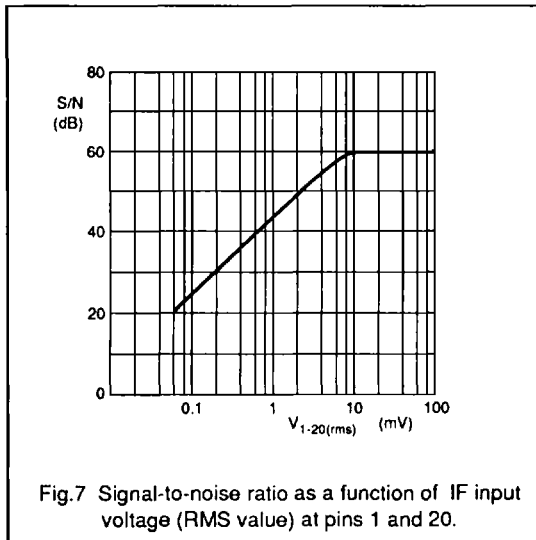

Fig.7 Signal-to-noise ratio as a function of IF input voltage (RMS value) at pins 1 and 20.

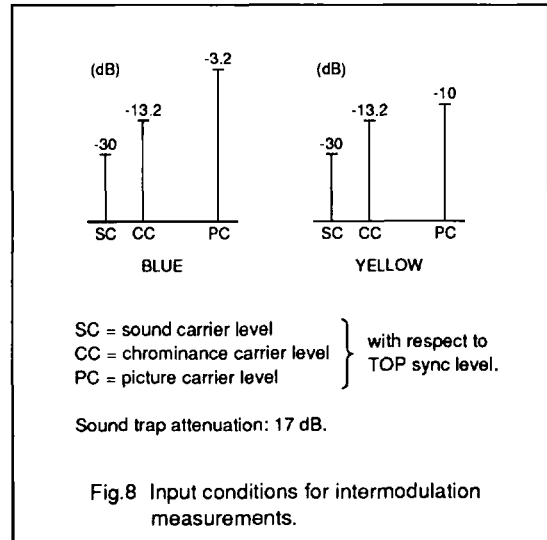
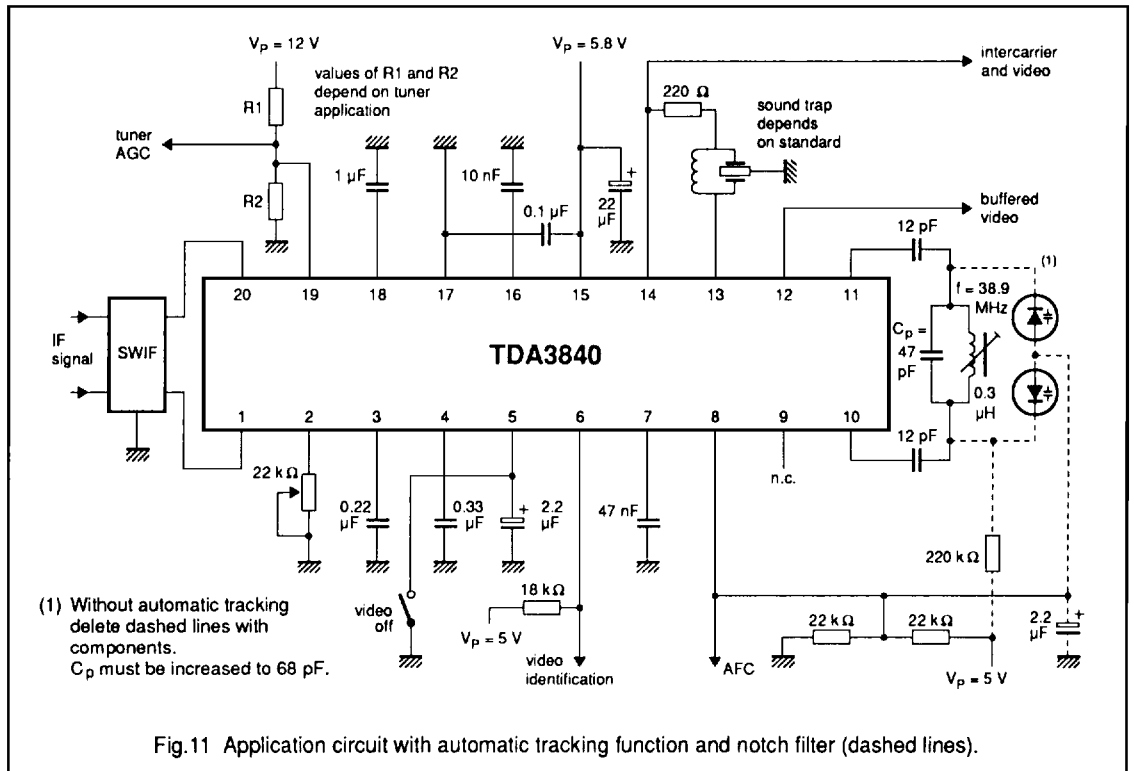
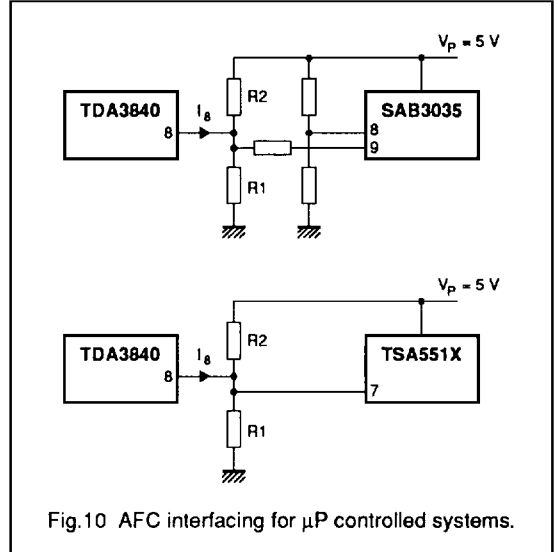
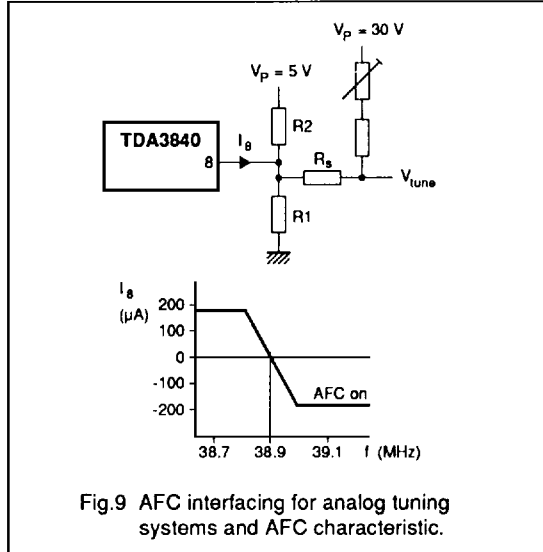

Fig.8 Input conditions for intermodulation measurements.

# TV IF amplifier and demodulator with TV signal identification

## TDA3840

### APPLICATION INFORMATION



# TV IF amplifier and demodulator with TV signal identification

## TDA3840

### APPLICATION INFORMATION (continued)

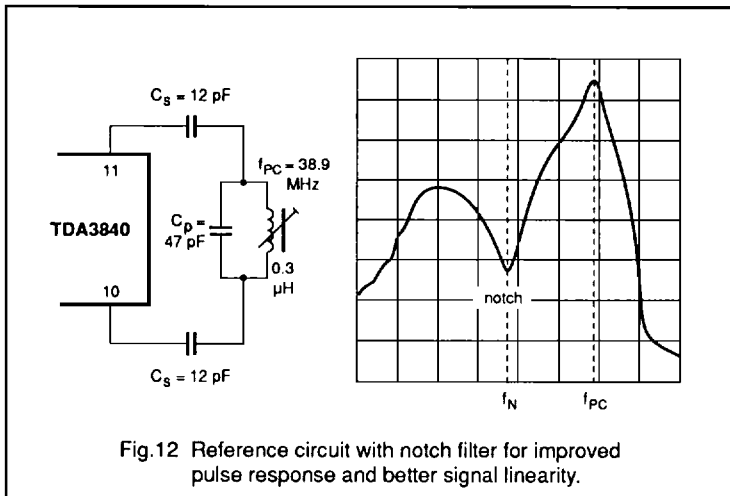

Fig.12 Reference circuit with notch filter for improved pulse response and better signal linearity.

#### Note to Fig.12

Recommended for reception of data signals e.g. in Teletext. Values in combination with SAW filter OFW G 1956 (Siemens). Curve shows combined frequency response of SAW filter and reference circuit.

For different standards  $C_S$  and  $C_P$  are calculated as follows:

$$C_S = 2 C_P \left\{ \frac{f_{PC}^2}{f_N^2} - 1 \right\}$$