

AA3022EC-4.5SF HIGH EFFICIENCY RED  
 AA3022SGC-4.5SF SUPER BRIGHT GREEN  
 AA3022YC-4.5SF YELLOW

### Features

- 3.0mm x 2.2mm SMT LED, 1.5mm THICKNESS.
- WHITE REFLECTOR TO MAXIMIZE REFLECTION OF LIGHT.
- ULTRA-COMPACT TYPE ASSURES SPACE SAVING.
- HIGH EFFICIENCY & LOW POWER CONSUMPTION.
- PACKAGE : 1500PCS / REEL.

### Description

The High Efficiency Red source color devices are made with Gallium Arsenide Phosphide on Gallium Phosphide Orange Light Emitting Diode.

The Super Bright Green source color devices are made with Gallium Phosphide Green Light Emitting Diode.

The Yellow source color devices are made with Gallium Arsenide Phosphide on Gallium Phosphide Yellow Light Emitting Diode.

### Package Dimensions

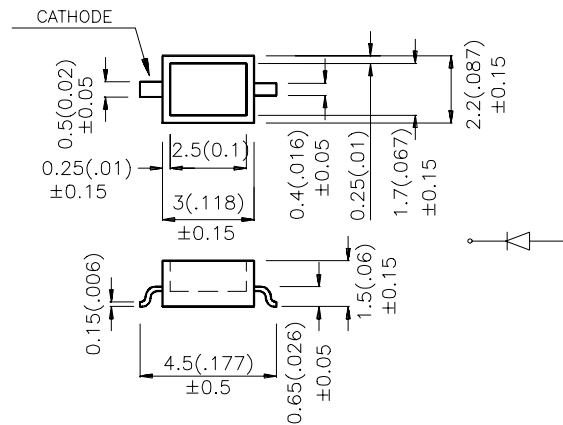

#### Notes:

1. All dimensions are in millimeters (inches).
2. Tolerance is ±0.25(0.01") unless otherwise noted.
3. Lead spacing is measured where the lead emerge package.
4. Specifications are subject to change without notice.

## Selection Guide

Part No.	Dice	Lens Type	Iv (mcd) @ 20 mA		Viewing Angle
			Min.	Typ.	2θ1/2
AA3022EC-4.5SF	HIGH EFFICIENCY RED(GaAsP/GaP)	WATER CLEAR	8	30	90°
AA3022SGC-4.5SF	SUPER BRIGHT GREEN (GaP)	WATER CLEAR	10	20	90°
AA3022YC-4.5SF	YELLOW (GaAsP/GaP)	WATER CLEAR	4	10	90°

Note:

1. θ1/2 is the angle from optical centerline where the luminous intensity is 1/2 the optical centerline value.

## Electrical / Optical Characteristics at T<sub>A</sub>=25°C

Symbol	Parameter	Device	Typ.	Max.	Units	Test Conditions
λ <sub>peak</sub>	Peak Wavelength	High Efficiency Red Super Bright Green Yellow	627 565 590		nm	IF=20mA
λ <sub>D</sub>	Dominate Wavelength	High Efficiency Red Super Bright Green Yellow	625 568 588		nm	IF=20mA
Δλ <sub>1/2</sub>	Spectral Line Halfwidth	High Efficiency Red Super Bright Green Yellow	45 30 35		nm	IF=20mA
C	Capacitance	High Efficiency Red Super Bright Green Yellow	15 15 20		pF	VF=0V;f=1MHz
V <sub>F</sub>	Forward Voltage	High Efficiency Red Super Bright Green Yellow	2.0 2.2 2.1	2.5 2.5 2.5	V	IF=20mA
I <sub>R</sub>	Reverse Current	High Efficiency Red Super Bright Green Yellow		10	uA	VR = 5V

## Absolute Maximum Ratings at T<sub>A</sub>=25°C

Parameter	High Efficiency red	Super Bright Green	Yellow	Units
Power dissipation	105	105	105	mW
DC Forward Current	30	25	30	mA
Peak Forward Current [1]	160	140	140	mA
Reverse Voltage	5	5	5	V
Operating Temperature	-40°C To +85°C			
Storage Temperature	-40°C To +85°C			

Note:

1. 1/10 Duty Cycle, 0.1ms Pulse Width.

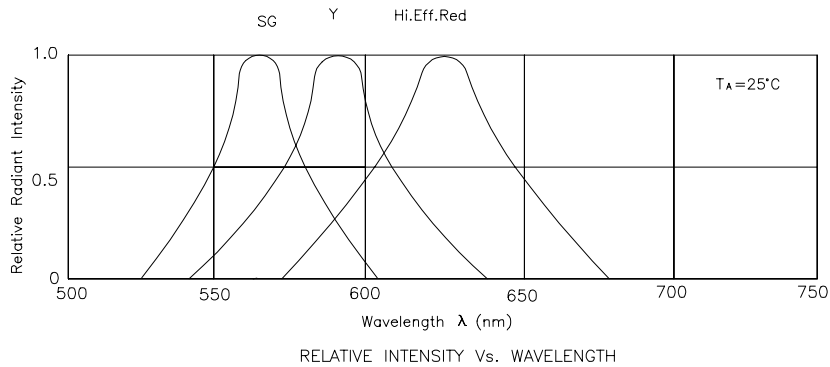

## High Efficiency Red AA3022EC-4.5SF

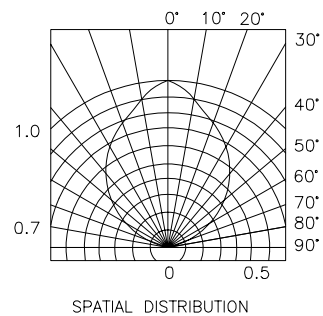
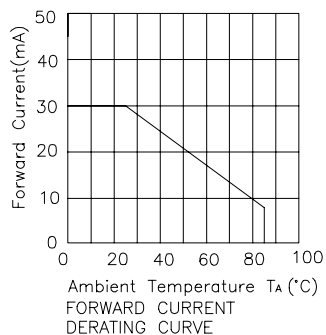
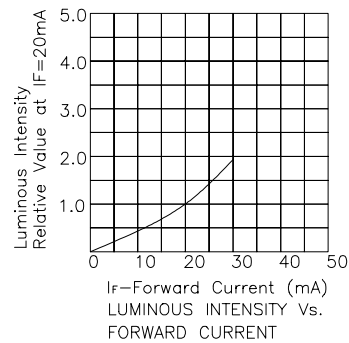
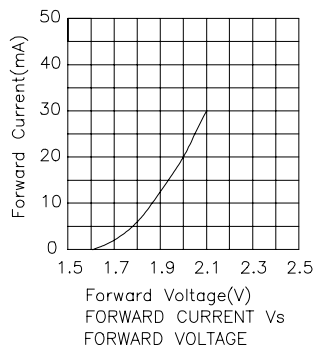

## Super Bright Green AA3022SGC-4.5SF

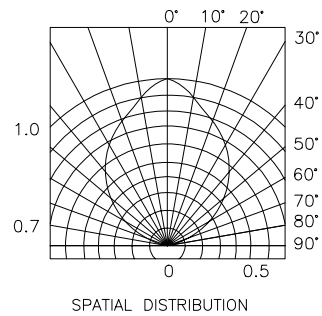
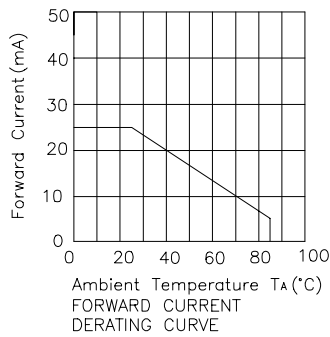
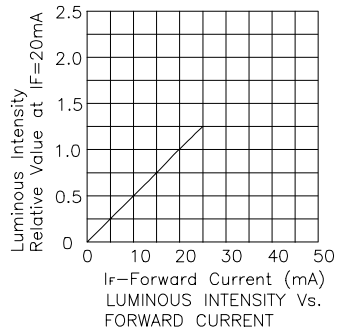
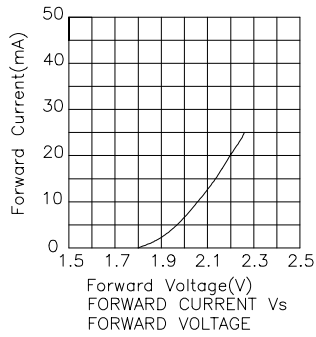

## Yellow AA3022YC-4.5SF

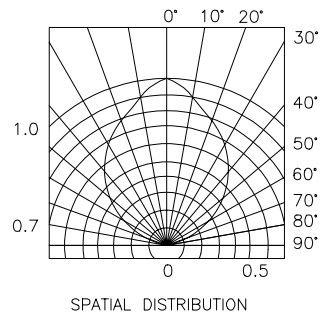
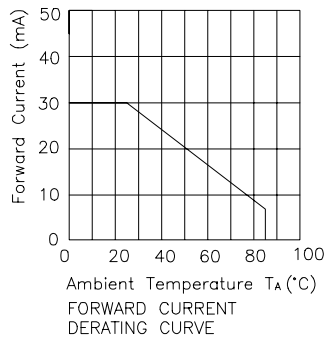
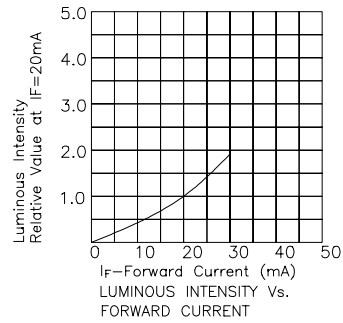
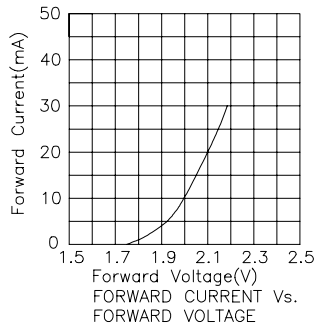

## AA3022 SMT Reflow Soldering Instructions

Number of reflow process shall be less than 2 times and cooling process to normal temperature is required between first and second soldering process.

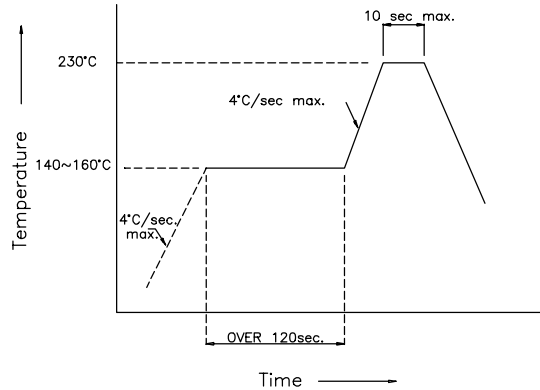

## Recommended Soldering Pattern (Units : mm)

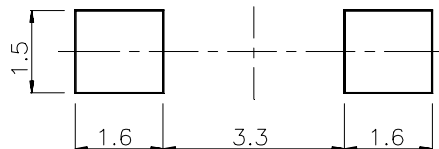

## Tape Specifications (Units : mm)

