



PARA LIGHT ELECTRONICS CO., LTD.

4F, No.1, Lane 93, Chien Yi Road, Chung Ho City, Taipei, Taiwan

Tel: 886-2-2225-3733

Fax: 886-2-2225-4800

E-mail: para@para.com.tw

<http://www.para.com.tw>

DATA SHEET

PART NO.: L-T69FRGBCT-SA

REV: A/0

CUSTOMER'S APPROVAL : _____

DCC : _____

DRAWING NO. : DS-7K-12-XXXX

DATE : 2012-11-9

PAGE

1 of 15

I Features

- Ū Top view PLCC6, Wide view angle, lighting color Red & Green & Blue.
- Ū EIA STD package, packing in 12mm tape on 7" diameter reels (ANSI/EIA-481-B-2001).
- Ū Compatible with automatic Pick & Place equipment.
- Ū Compatible with IR Reflow soldering and TTW soldering.
- Ū Pb free product and acceptable lead-free process!
- Ū Meet RoHS Green Product.

I Application

- Ū Backlighting (Switches, keys, displays, illuminated advertising)
- Ū Emergency lighting / Signal and symbol luminaries.
- Ū Decorative lighting.

I Package Outline Dimensions

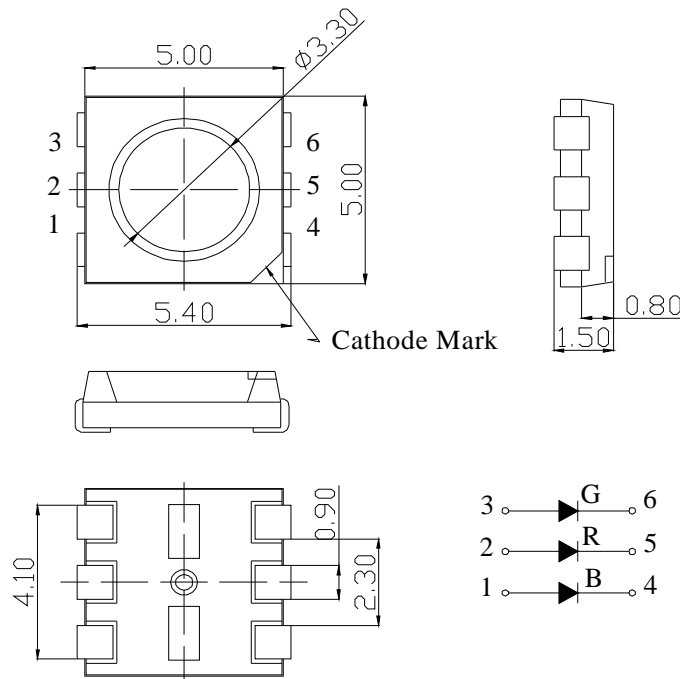

Notes:

1. All dimensions are in millimeters.
2. Tolerance is $\pm 0.10\text{mm}$ (.004") unless otherwise noted.



SURFACE MOUNT DEVICE LED

Part No. : L-T69FRGBCT-SA

REV: A/0

I Absolute Maximum Ratings(Ta=25°C)

Parameter	Symbol		Rating	Unit
Continuous Forward Current	If	R	20	mA
		G		
		B		
Pulse Forward Current*	Ifp	R	100	mA
		G		
		B		
Power Consumption	Pc	R	55	mW
		G	75	
		B	75	
Electrostatic Discharge	ESD	R	2000	V
		G	1000	
		B	1000	
Operating Temperature Range	Topr		-40~+85	°C
Storage Temperature Range	Tstg		-40~+100	°C
Reverse Voltage	Vr		5	V
Soldering Temperature	Tslid		Reflow Soldering: 240°C/10sec	
			Hand Soldering:350°C/3sec	

I Electro-Optical Characteristics (Ta=25°C)

Item	Symbol		Conditio	Min	Typ	Max	Unit
Forward Voltage	Vf	R	If=20mA		2.0	2.4	v
		G		3.0	3.6		
		B		3.0	3.6		
Dominant Wavelength	λD	R	If=20mA	619		629	nm
		G		520		530	
		B		465		475	
Viewing Angle 2θ 1/2	Δθ		If=20mA		120		deg
Luminous Intensity	Iv	R	If=20mA	350	480		mcd
		G		800	1200		
		B		190	280		

Notes:

1. Luminous intensity is measured with a light sensor and filter combination that proximates the CIE eye-response curve.
2. $\theta_{1/2}$ is the off-axis angle at which the luminous intensity is half the axial luminous intensity.
3. Caution in ESD :
Static Electricity and surge damages the LED. It is recommended use a wrist band or anti-electrostatic glove when handling the LED. All devices, equipment and machinery must be properly grounded.
4. Major standard testing equipment by "Instrument System" Model : CAS140B Compact Array Spectrometer and "KEITHLEY" Source Meter Model : 2400.

I Typical Electro-Optical Characteristics Curves

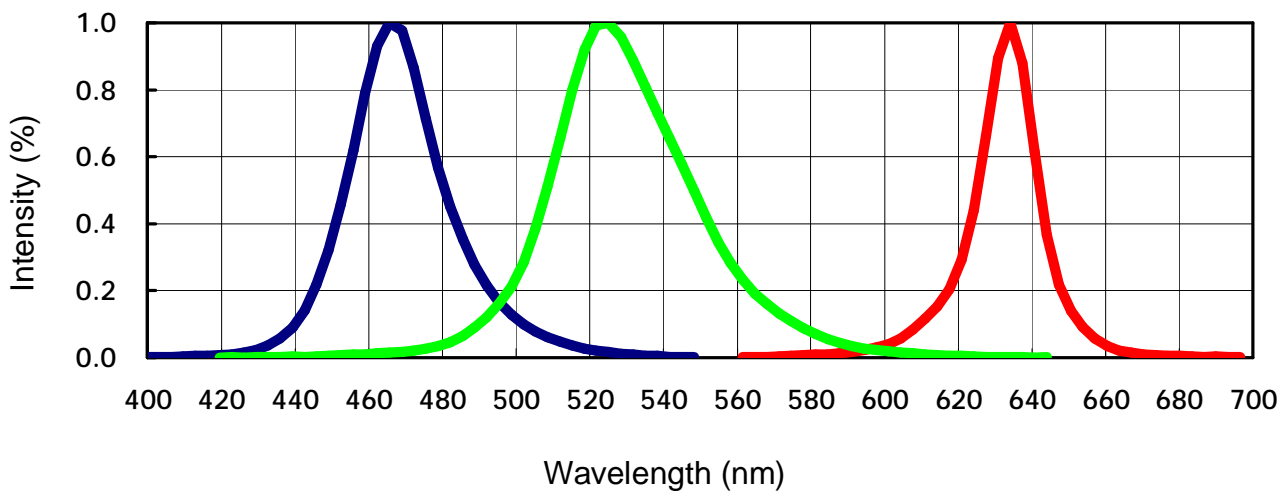

Relative Intensity VS Wavelength

I Typical Electro-Optical Characteristics Curves

(25°C Ambient Temperature Unless Otherwise Noted)

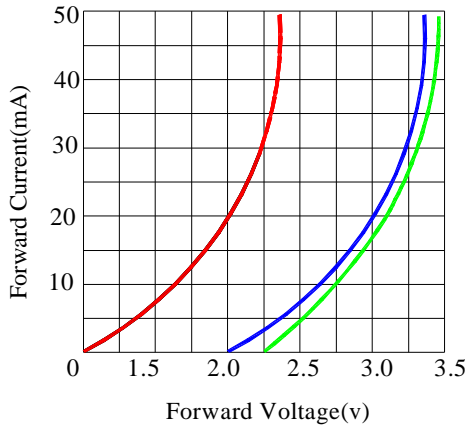

Fig.1 Forward Current vs. Forward Voltage

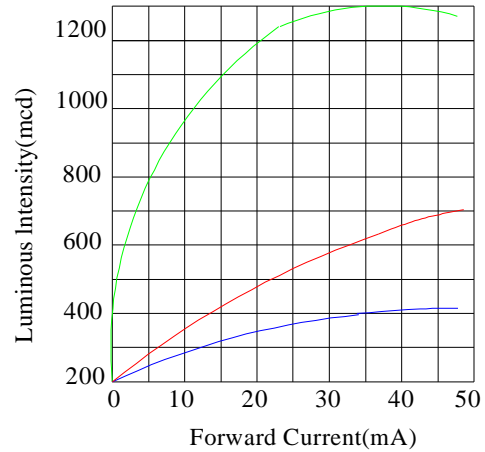

Fig.2 Luminous Intensity vs. Forward Current

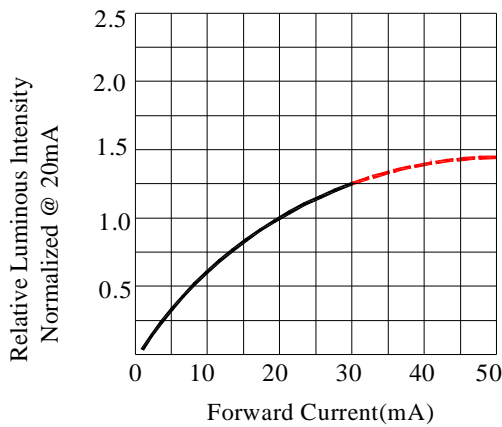

Fig.3 Relative Luminous Intensity vs. Forward Current

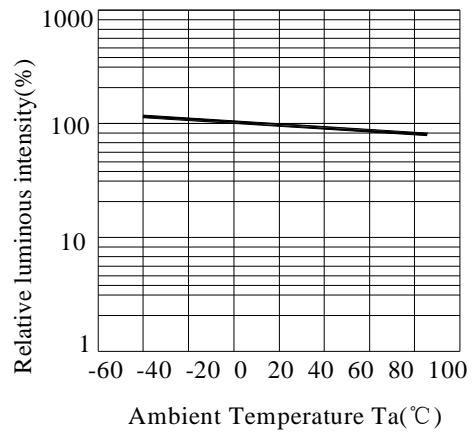

Fig.4 Luminous Intensity vs. Ambient Temperature

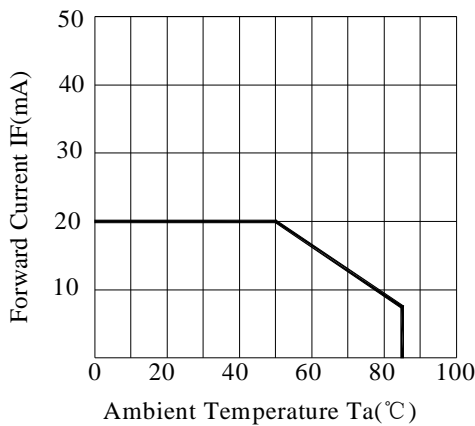

Fig.5 Forward Current Derating Curve

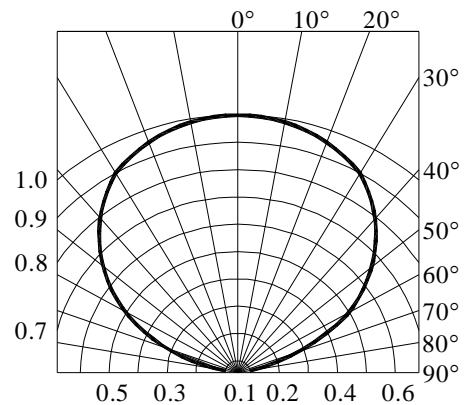

Fig.6 Relative Intensity vs. Angle



SURFACE MOUNT DEVICE LED

Part No. : L-T69FRGBCT-SA

REV: A/0

I Bin Code List

Luminous Intensity(IV), Unit:mcd@20mA				Forward Voltage(VF), Unit:V@20mA			
COLOR	Bin Code	Min	Max	COLOR	Bin Code	Min	Max
R	P17	350	430	R	4	1.9	2.0
	P18	430	530		5	2.0	2.1
	P19	530	650		6	2.1	2.2
	P20	650	800		7	2.2	2.3
G	P21	800	1000	8	2.3	2.4	
	P22	1000	1250	9	2.4	2.5	
	P23	1250	1550	13	2.8	2.9	
B	P14	190	230	14	2.9	3.0	
	P15	230	280	15	3.0	3.1	
	P16	280	350	16	3.1	3.2	
Tolerance of each bin are±10%				G(B)	17	3.2	3.3
					18	3.3	3.4
					19	3.4	3.5
					20	3.5	3.6
					20	3.5	3.6

Tolerance of each bin are±0.1Vol

Dominant Wavelength (Hue),Unit: nm@20mA			
COLOR	Bin Code	Min	Max
R	OC1	619	624
	OC2	624	629
G	AP	520	525
	AQ	525	530
B	AC	465	470
	AD	470	475

Tolerance of each bin are±1nm



SURFACE MOUNT DEVICE LED

Part No. : L-T69FRGBCT-SA

REV: A/0

Label Explanation



CUS. PART NO: To be denominated.

CUSTOMER: To be denominated.

PART NO: Refer to P16

IV--- Luminous Intensity Code

WD--- Dominant Wavelength

LOT NO: E L P 1 1 0001
 A B C D E F

A---E: For series number

B---L: Local F: Foreign

C---P: PLCC SMD

D--- Year

E---Month

F---SPEC.

PACKING QUANTITY OF BAG :

2000pcs max for T670 series

2000pcs max for T650 series

2000pcs max for S020 series

1000pcs max for T690 series

DATE CODE: 2011 01 08
 G H I

G--- Year

H--- Month

I --- Day

Reel Dimensions

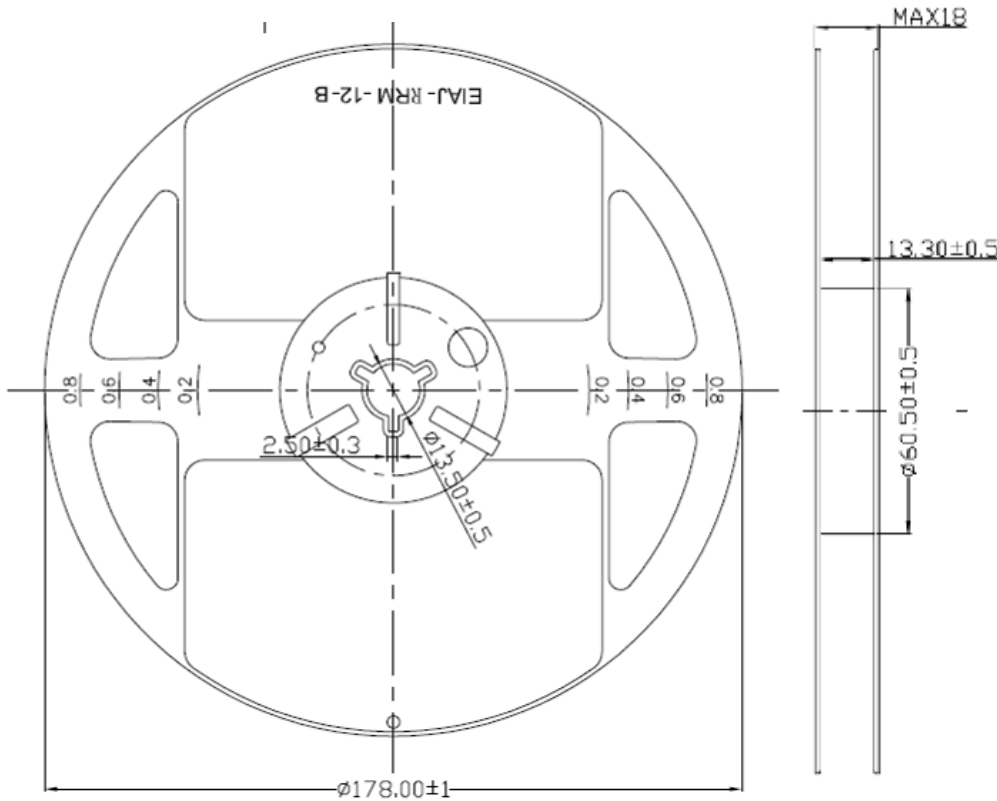

Notes:

1. Taping Quantity : 1000pcs/reel、 500pcs/reel
2. The tolerances unless noted is ± 0.1 mm, Angle $\pm 0.5^\circ$, Unit: mm.

Suggest Soldering Pad Dimensions

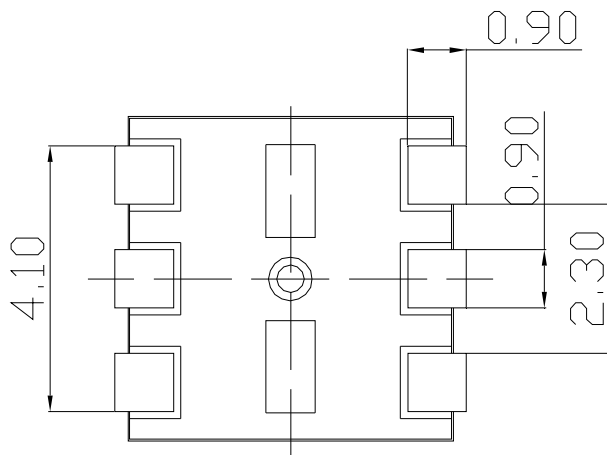

I Package Dimensions Of Tape And Reel

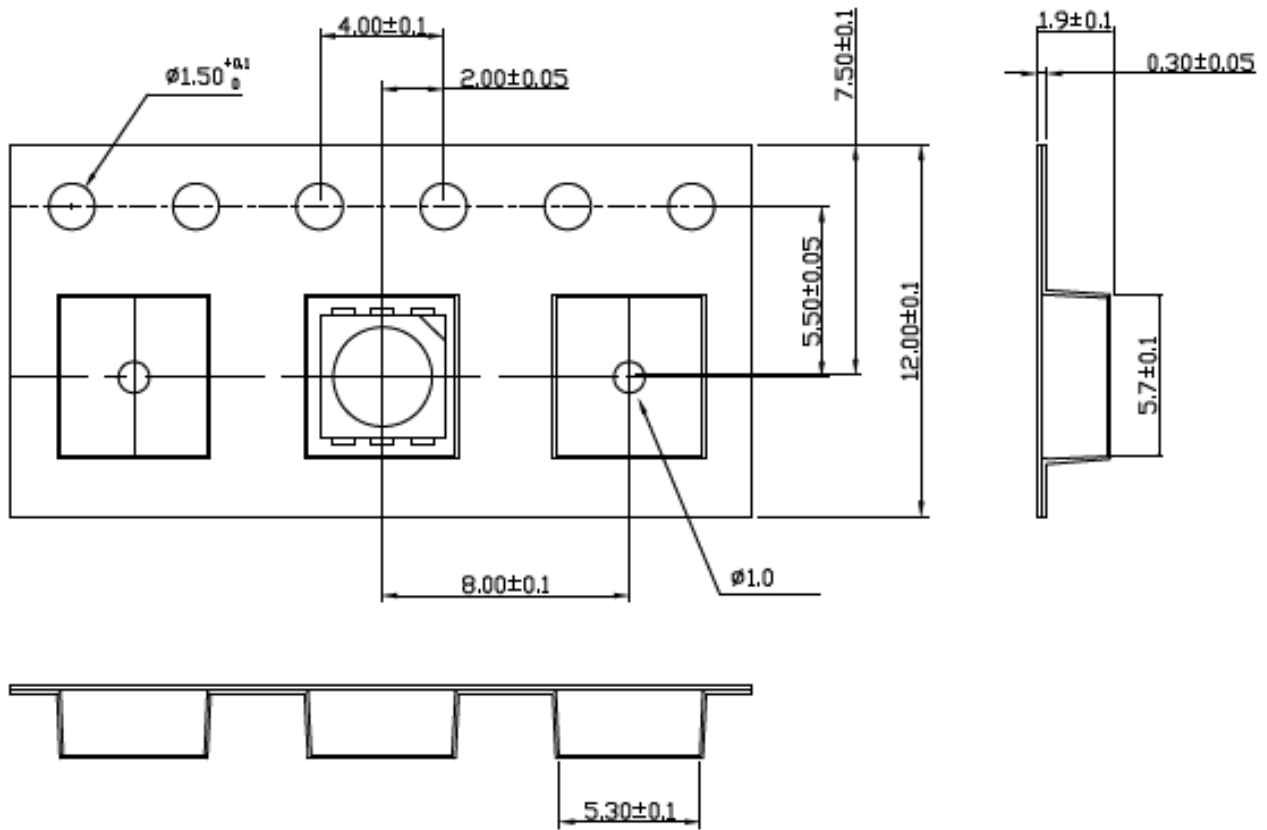

Notes: All dimensions are in millimeters.

I Moisture Resistant Packaging

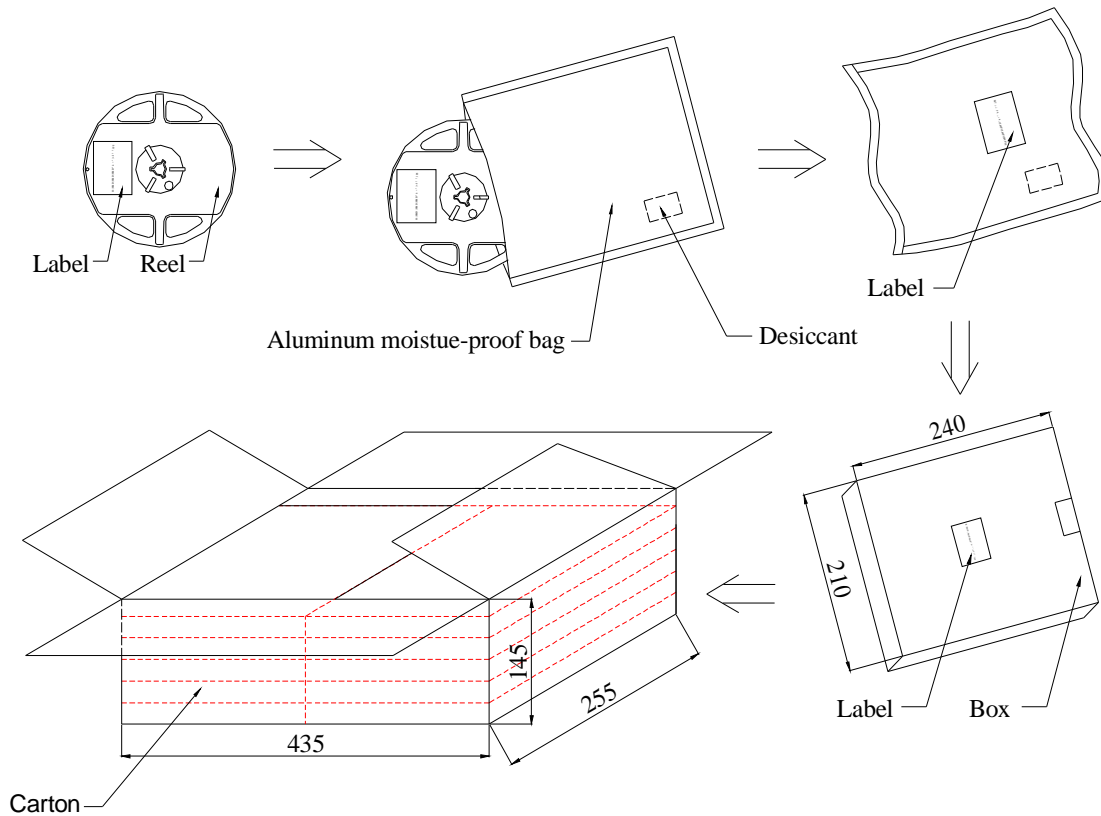

Notes : One reel in a bag, one bag in a inner box, ten inner boxes in a carton. Unit : mm.

I Cleaning

- Ū If cleaning is required , use the following solutions for less than 1 minute and less than 40°C .
- Ū Appropriate chemicals: isopropyl alcohol. (When using other solvents, it should be confirmed beforehand whether the solvents will dissolve the package and the resin or not.)
- Ū Effect of ultrasonic cleaning on the LED resin body differs depending on such factors as ultrasonic power and the assembled condition. Before cleaning, a pre-test should be confirm whether any damage to the LEDS will occur.

● Suggest Sn/Pb IR Reflow Soldering Profile Condition:

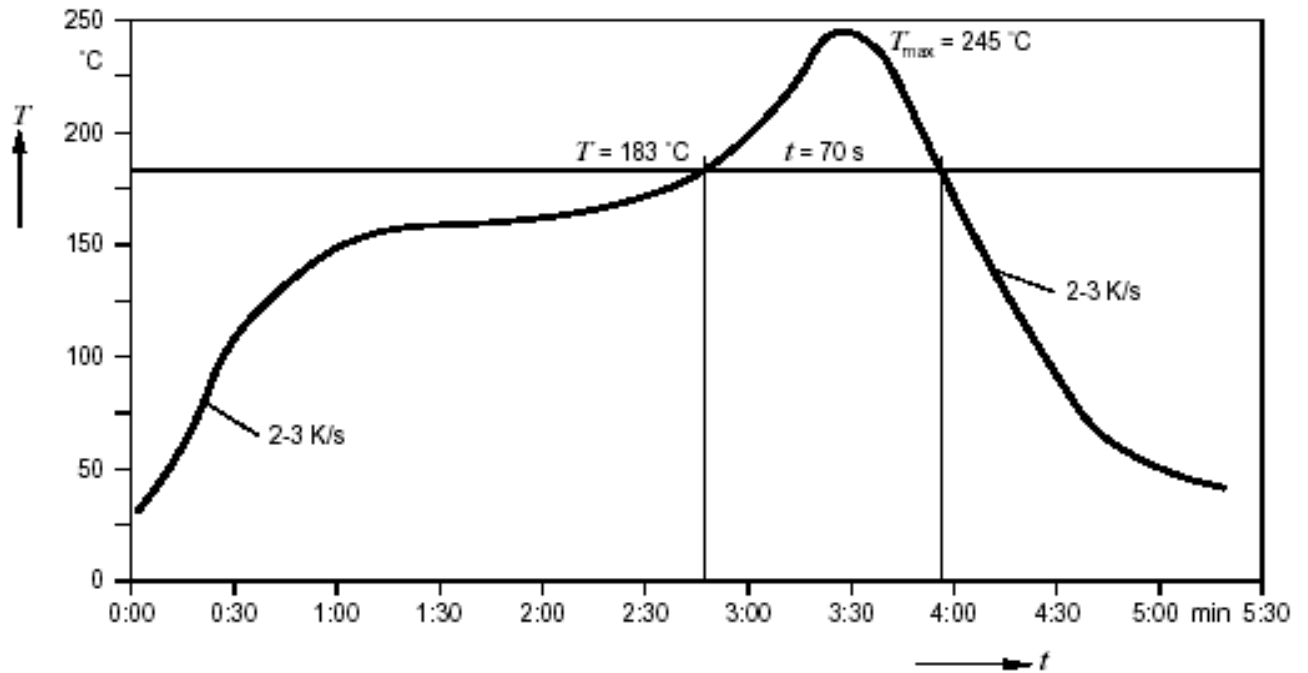

● Suggest Pb-Free IR Reflow Soldering Profile Condition:

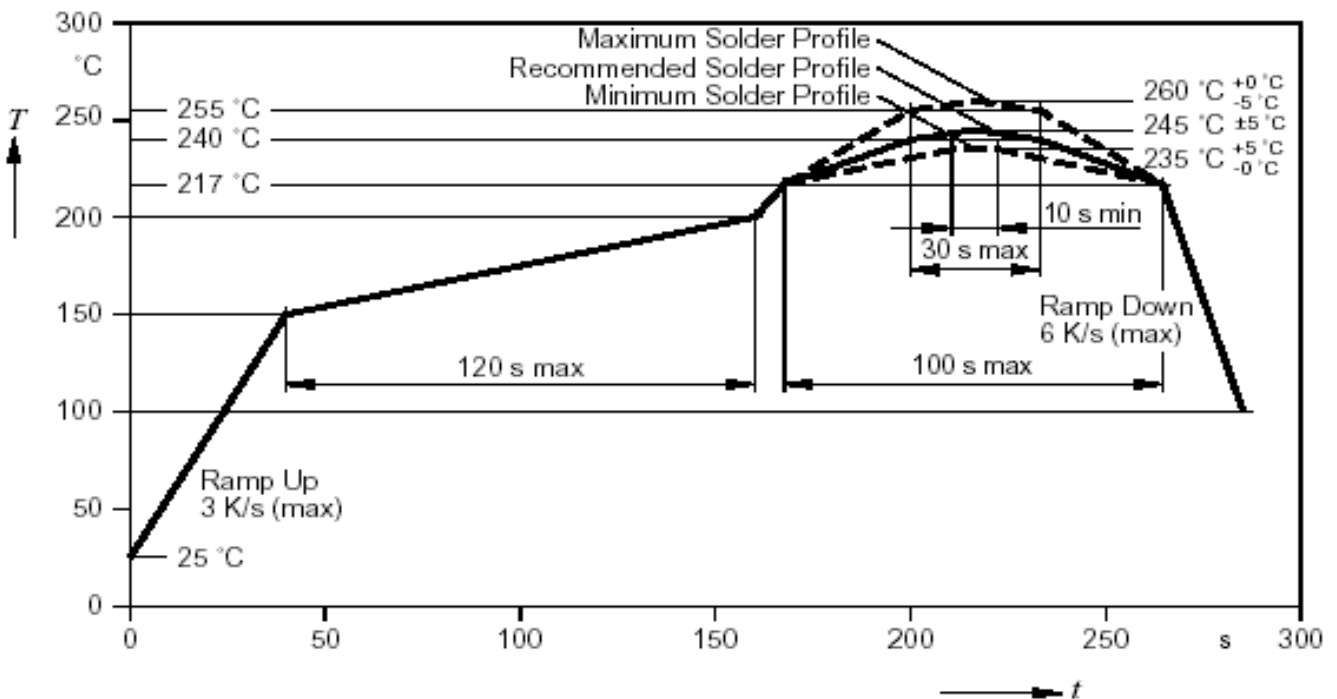



SURFACE MOUNT DEVICE LED

Part No. : L-T69FRGBCT-SA

REV: A/0

I CAUTIONS

1. Static Electricity:

- * Static electricity or surge voltage damages the LEDs.

It is recommended that a wrist band or an anti-electrostatic glove be used when handling the LEDs.

- * All devices, equipment and machinery must be properly grounded.

It is recommended that measures be taken against surge voltage to the equipment that mounts the LEDs.

- * When inspecting the final products in which LEDs were assembled, it is recommended to check whether the assembled LEDs are damaged by static electricity or not. It is easy to find static-damaged LEDs by a light-on test or a VF test at a lower current (blew 1mA is recommended).

* Damaged LEDs will show some unusual characteristics such as the leak current remarkably increases, the forward voltage becomes lower, or the LEDs do not light at the low current.

Criteria: (VF>2.0V, at IF=0.5mA)

2. Storage :

- * Before opening the package :

The LEDs should be kept at 30°C or less and 85%RH or less. When storing the LEDs, moisture proof packaging with absorbent material (silica gel) is recommended.

- * After opening the package :

The LEDs should be kept at 30°C or less and 70%RH or less. The LEDs should be soldered within 168 hours (7 days) after opening the package. If unused LEDs remain, they should be stored in moisture proof packages, such as sealed containers with packages of moisture absorbent material (silica gel). It is also recommended to return the LEDs to the original moisture proof bag and to reseal the moisture proof bag again.

If the moisture absorbent material (silica gel) has faded away or the LEDs have exceeded the storage time, baking treatment should be performed using the following conditions.

Baking treatment: more than 24hours at 65±5°C.

- * Please avoid rapid transitions in ambient temperature in high humidity environments where condensation may occur.

3. Soldering:

Do not apply any stress to the LED lens during soldering while the LED is at high temperature.

Recommended soldering condition.

- * Reflow Soldering :

Pre-heat 120~150°C, 120sec. MAX., Peak temperature : 240°C Max. Soldering time : 10 sec Max.

- * Soldering Iron : (Not recommended)

Temperature 350°C Max., Soldering time : 3 sec. Max.(one time only), power dissipation of iron :

20W Max. use SN60 solder of solder with silver content and don't touch LED lens when soldering.

4. Lead-Free Soldering

For Reflow Soldering :

- 1、Pre-Heat Temp: 150-200°C,120sec.Max.
- 2、Soldering Temp: Temperature Of Soldering Pot Over 240°C,30sec.Max.
- 3、Peak Temperature: 260°C、10sec.
- 4、Reflow Repetition: 2 Times Max.
- 5、Suggest Solder Paste Formula : 93.3 Sn/3.1 Ag/3.1 Bi/0.5 Cu

For Soldering Iron (Not Recommended) :

- 1、Iron Tip Temp: 350°C Max.
- 2、Soldering Iron: 30w Max.
- 3、Soldering Time: 3 Sec. Max. One Time.

5. Drive Method

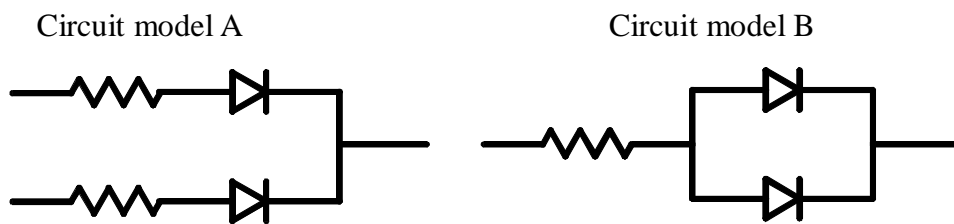

(A)Recommended circuit.

(B)The difference of brightness between LED`s could be found due to the Vf-If characteristics of LED.

6. Reliability

1、Criteria For Judging The Damage

Item	Symbol	Test Conditions	Criteria for Judgement	
			MIN.	Max.
Forward Voltage	VF	IF=20mA	-	U.S.L.*)×1.1
Reverse Current	IR	VR=5V	-	U.S.L.*)×2.0
Luminous Intensity	IV	IF=20mA	L.S.L***)×0.7	-

*) U.S.L.: Upper Standard Level

**) L.S.L: Lower Standard Level



SURFACE MOUNT DEVICE LED

Part No. : L-T69FRGBCT-SA

REV: A/0

2、 Test Items And Results

Test Item	Reference Standard	Test Condition	Note	Number of Damaged
Resistance to Soldering Heat (Reflow Soldering)	JEITA ED-4701300 301	Tsld=260°C,10sec. (Pre treatment 30°C,70%,168hrs)	2times	0/50
Solder ability (Reflow Soldering)	JEITA ED-4701300 303	Tsld=215°C,3sec. (Lead Solder)	1time over 95%	0/50
Thermal Shock	JEITA ED-4701300 307	-40°C ~ 100°C 30min. 30min.	100cycles	0/50
Temperature Cycle	JEITA ED-4701100 105	-40°C ~ 25°C~100°C~25°C 30min. 5min. 30min. 5min	100cycles	0/50
High Temperature Storage	JEITA ED-4701200- 201	Ta=100°C	1000hrs.	0/50
Temperature Humidity Storage	JEITA ED-4701100 103	Ta=60°C,RH=90%	1000hrs.	0/50
Low Temperature Storage	JEITA ED-4701200 202	Ta=-40°C	1000hrs.	0/50
Steady State Operating Life Condition		Ta=25°C,IF=20mA	1000hrs.	0/50
Steady State Operating Life of High Humidity Heat		Ta=60°C,RH=90%,IF=15mA	500hrs.	0/50

7.Others:

The appearance and specifications of the product may be modified for improvement without notice.



SURFACE MOUNT DEVICE LED

Part No. : L-T69FRGBCT-SA

REV: A/0

I PART NO. SYSTEM :

L - T 69 F RGB C T Z - XXXX

XXXX : Special Code
(Such as CCT、Luminous or others)

Z: With zener
(It not be showed if with no zener)

T : Taping for 7 inch reel

Lens color
C : Water Clear
W : White Diffused
D : Color Diffused

KY : 9mil AlInGap 590nm Super Yellow
KR : 9mil AlInGap 630 nm Super Red
TE(HE) : 14mil AlInGap 624 nm Super Red
TY(HY): 14mil AlInGap590 nm Super Yellow
LB : InGaN ITO rough 470nm Blue
LG(SG) : InGaN ITO rough520nm Green
W : InGaN + YAG White color
.....

0 : Single chip
1/2 : Super thin single chip
5/6 : Dual chip
F : Three chip(Full color)

65 : 3020 1.3T TYPE
67 : 3528 1.9T TYPE
020 : 3812 0.6T TYPE
68: 5630 0.9T TYPE
69: 5050 1.5T TYPE

C : PCB Top View Type
T :PLCC Top View Type
S : Side View Type