

NCV7718

Hex Half-Bridge Driver

The NCV7718 is a Hex Half-Bridge Driver with protection features designed specifically for automotive and industrial motion control applications. The NCV7718 has independent controls and diagnostics. The device can be operated in forward, reverse, brake, and high impedance states. The drivers are controlled via a 16 bit SPI interface and are daisy chain compatible.

Features

- Low Quiescent Current Sleep Mode
- High-Side and Low-Side Drivers Connected in a Half-Bridge Configuration
- Integrated Freewheeling Protection (LS and HS)
- 0.55 A Peak Current
- $R_{DS(on)} = 1 \Omega$ (typ)
- 5 MHz SPI Control
- Compliance with 5 V and 3.3 V Systems
- Undervoltage and Overvoltage Lockout
- Discriminated Fault Reporting
- Overcurrent Protection
- Overtemperature Protection
- Under Load Detection
- Daisy Chain Compatible with Multiple of 8 bit Devices
- 16-Bit Frame Detection
- These are Pb-Free Devices

Typical Applications

- Automotive
- Industrial
- DC Motor Management for HVAC Application



ON Semiconductor®

<http://onsemi.com>

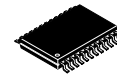

**SSOP24 NB
CASE 506AL**

MARKING DIAGRAM



NCV7718 = Specific Device Code
A = Assembly Location
WL = Wafer Lot
YY = Year
WW = Work Week
G = Pb-Free Package

ORDERING INFORMATION

See detailed ordering and shipping information in the package dimensions section on page 26 of this data sheet.

NCV7718

Shown below is a typical application for the NCV7718 configuration.

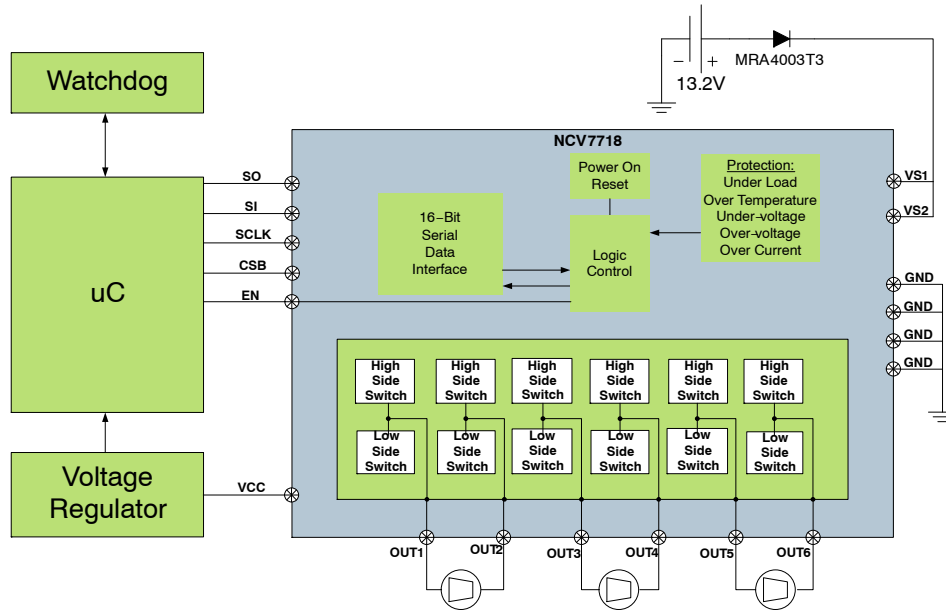

Figure 1. Typical Application

NCV7718

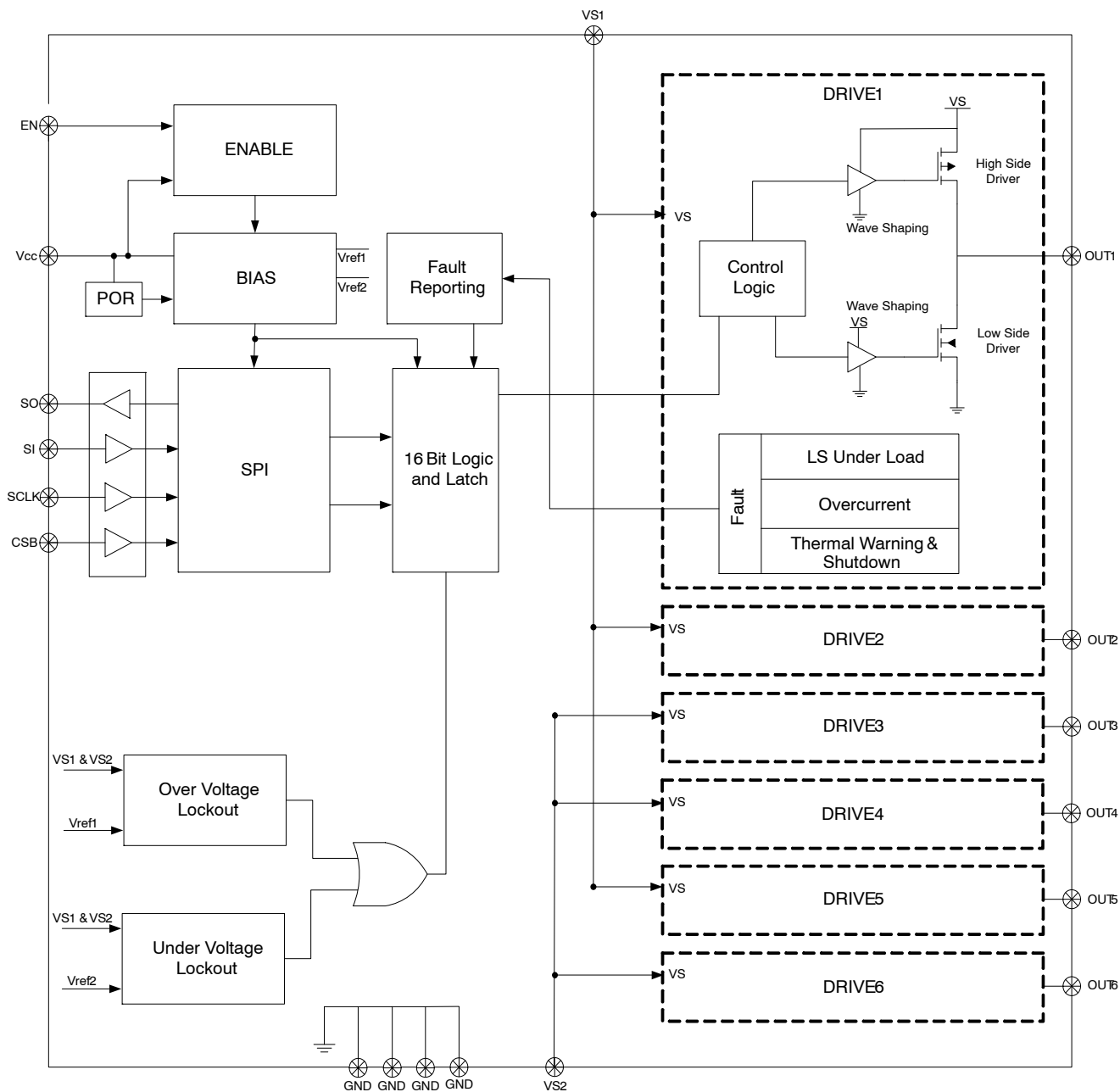

Figure 2. Block Diagram

NCV7718

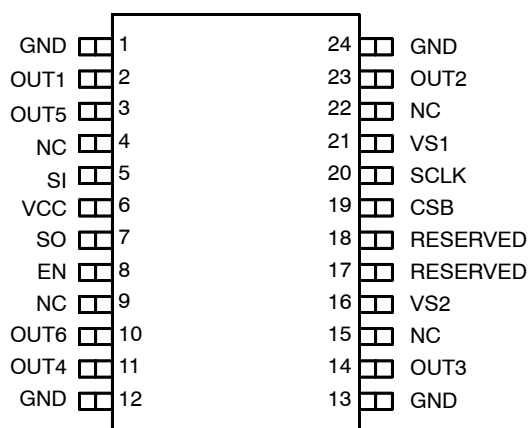

Figure 3. Pinout – SSOP24

PACKAGE DESCRIPTION The pin-out for the Hex Half-Bridge in SSOP24 package is shown in the table below.

Pin # SSOP24	Symbol	Description
1	GND	Ground. Shorted to pin 24 internally.
2	OUT1	Half Bridge Output 1
3	OUT5	Half Bridge Output 5
4	NC	No Connection. This pin should be isolated from any traces or via on the PCB board.
5	SI	Serial Input. 16 bit serial communications input. 3.3 V/5 V (TTL) Compatible. Internally pulled down.
6	VCC	Power supply input for Logic.
7	SO	Serial Output. 16 bit serial communications output. 3.3 V/5 V Complaint
8	EN	Enable. Input high wakes the IC up from a sleep mode. 3.3 V/5 V (TTL) Compatible. Internally pulled down.
9	NC	No Connection. This pin should be isolated from any traces or via on the PCB board.
10	OUT6	Half Bridge Output 6
11	OUT4	Half Bridge Output 4
12	GND	Ground. Shorted to pin 13 internally.
13	GND	Ground. Shorted to pin 12 internally.
14	OUT3	Half Bridge Output 3
15	NC	No Connection. This pin should be isolated from any traces or via on the PCB board.
16	VS2	Voltage Power Supply input for the Drivers 3, 4 and 6. This pin must be connected to VS1 externally.
17	Reserved	Reserved for internal use. This pin must be grounded.
18	Reserved	Reserved for internal use. This pin must be grounded.
19	CSB	Chip Select Bar. Active low serial port operation. 3.3V/5V (TTL) Compatible. Internally pulled up.
20	SCLK	Serial Clock. Clock input for use with SPI communication. 3.3 V/5 V (TTL) Compatible. Internally pulled down.
21	VS1	Voltage Power Supply input for the Drivers 1, 2 and 5, all the pre-drivers and the charge pump. This pin must be connected to VS2 externally.
22	NC	No Connection. This pin should be isolated from any traces or via on the PCB board.
23	OUT2	Half Bridge Output 2
24	GND	Ground. Shorted to pin 1 internally.

NCV7718

MAXIMUM RATINGS

Rating	Symbol	Value	Unit
Power Supply Voltage (VS1, VS2) (DC) (AC), t < 500ms, Ivsx > -2A	VsxdcMax VSXac	-0.3 to 40 -1.0	V
Output Pin OUTx (DC) (AC) (AC), t < 500ms, IOUtX > -1.1A (AC), t < 500ms, IOUtX < 1A	VoutxDc VoutxAc	-0.3 to 40 -0.3 to 40 -1.0 1.0	V
Pin Voltage (Logic Input pins, SI, SCLK, CSB, SO, EN, Vcc)	VioMax	-0.3 to 5.5	V
Output Current (OUT1, OUT2, OUT3, OUT4, OUT5, OUT6)	IoutXlmax	-2.0 to 2.0	A
Electrostatic Discharge, Human Body Model, VSx, OUTx	Vesd4k	4.0	kV
Electrostatic Discharge, Human Body Model, all other pins	Vesd2k	2.0	kV
Electrostatic Discharge, Machine Model	Vesd200	200	V
Short Circuit Reliability Characterization	AECQ10x	Grade A	-
Operating Junction Temperature	Tj	-40 to 150	°C
Storage Temperature Range	Tstr	-55 to 150	°C
Moisture Sensitivity Level (MAX 260°C Processing)	MSL3	3	-

Stresses exceeding Maximum Ratings may damage the device. Maximum Ratings are stress ratings only. Functional operation above the Recommended Operating Conditions is not implied. Extended exposure to stresses above the Recommended Operating Conditions may affect device reliability.

THERMAL INFORMATION (Note 1)

Rating	Symbol	Value	Unit
Junction to Ambient	R _{θJA}	95.2	°C/W
Junction to Lead	R _{ψJL}	62	°C/W

1. Thermal Information is based on having 3 high side and 3 low side devices dissipating 80 mW each on a 2 layer board 0.062" thick FR4 board with 600 mm² copper spreader area. 2 oz copper is used for the copper spreader area and the ambient temperature is specified at 25°C.

RECOMMENDED OPERATING CONDITIONS

Rating	Symbol	Value		Unit
		Min	Max	
Digital Supply Input Voltage	VccOp	3.15	5.25	V
Battery Supply Input Voltage	VsxOp	5.5	28	V
DC Output Current	IxOp	-	0.55	A
Junction Temperature	TjOp	-40	125	°C

NCV7718

ELECTRICAL CHARACTERISTICS ($-40^{\circ}\text{C} < T_J < 150^{\circ}\text{C}$, $5.5\text{ V} < V_{Sx} < 40\text{ V}$, $3.15\text{ V} < V_{CC} < 5.25\text{ V}$, $EN = V_{CC}$, unless otherwise specified)

Characteristic	Symbol	Conditions	Min	Typ	Max	Unit
GENERAL						
Supply Current ($V_{S1} + V_{S2}$) Sleep Mode	I_{qVsx85}	$V_{S1} = V_{S2} = 13.2\text{ V}$, $V_{CC} = 0\text{ V}$ -40°C to 85°C	–	1.0	2.5	μA
Supply Current ($V_{S1} + V_{S2}$) Active Mode	I_{vsOp}	$EN = V_{CC}$, $5.5\text{ V} < V_{Sx} < 28\text{ V}$ No Load	–	2.5	5.0	mA
Supply Current (V_{CC}) Sleep Mode	$I_{qV_{CC}}$	$CSB = V_{CC}$, $EN = SI = SCLK = 0\text{ V}$ (-40°C to 85°C)	–	1.0	2.5	μA
Active Mode	$I_{V_{CC}Op}$	$EN = CSB = V_{CC}$, $SI = SCLK = 0\text{ V}$ No Load	–	1.5	3.0	mA
Total Sleep Mode Current $I(V_{S1}) + I(V_{S2}) + I(V_{CC})$	I_{qTot}	Sleep Mode, -40°C to 85°C	–	2	5	μA
V_{CC} Power-On-Reset Threshold	V_{ccpor}	V_{CC} increasing	–	2.55	2.9	V
V_{Sx} Undervoltage Detection Threshold	V_{sXuv}	V_{Sx} decreasing	3.7	4.1	4.5	V
V_{Sx} Undervoltage Detection Hysteresis	V_{sXuHys}		100	–	450	mV
V_{Sx} Overvoltage Detection Threshold	V_{sXov}	V_{Sx} increasing	32	36	40	V
V_{Sx} Overvoltage Detection Hysteresis	V_{sXoHys}		1	2.5	4	V

THERMAL RESPONSE

Thermal Warning	T_{wr}	Not ATE tested	120	140	170	$^{\circ}\text{C}$
Thermal Warning Hysteresis	T_{wHy}	Not ATE tested	–	20	–	$^{\circ}\text{C}$
Thermal Shutdown	T_{sd}	Not ATE tested	150	175	200	$^{\circ}\text{C}$
Thermal Shutdown Hysteresis	T_{sdHy}	Not ATE tested	–	20	–	$^{\circ}\text{C}$

OUTPUTS

Output High $R_{DS(on)}$ (source)	R_{DSonHS}	$I_{out} = -500\text{ mA}$ $6\text{ V} < V_s < 40\text{ V}$	–	1	2.25	Ω
Output Low $R_{DS(on)}$ (sink)	R_{DSonLS}	$I_{out} = 500\text{ mA}$ $6\text{ V} < V_s < 40\text{ V}$	–	1	2.25	Ω
Source Leakage Current	$I_{srcLkg13.2}$ $I_{srcLkg40}$	$OUT(1-6) = 0\text{ V}$, $V_{Sx} = 13.2\text{ V}$, $V_{CC} = 5\text{ V}$ $OUT(1-6) = 0\text{ V}$, $V_{Sx} = 40\text{ V}$, $V_{CC} = 5\text{ V}$	-1.0 -5.0	– –	– –	μA
Sink Leakage Current	$I_{snkLkg13.2}$ $I_{snkLkg40}$	$OUT(1-6) = V_{Sx} = 13.2\text{ V}$, $V_{CC} = 5\text{ V}$ $OUT(1-6) = V_{Sx} = 40\text{ V}$, $V_{CC} = 5\text{ V}$	– –	– –	1.0 5.0	μA
Overcurrent Shutdown Threshold (Source)	I_{sdSrc}	$V_{CC} = 5\text{ V}$, $V_{Sx} = 13.2\text{ V}$	-2.0	-1.2	-0.8	A
Overcurrent Shutdown Threshold (Sink)	I_{sdSnk}	$V_{CC} = 5\text{ V}$, $V_{Sx} = 13.2\text{ V}$	0.8	1.2	2.0	A
Over Current Delay Timer	T_{dOc}		10	25	50	μs
Under Load Detection Threshold (Low Side)	I_{uldLS}	$V_{CC} = 5\text{ V}$, $V_{Sx} = 13.2\text{ V}$	2.0	11	20	mA
Under Load Detection Delay Time	T_{dUld}	$V_{CC} = 5\text{ V}$, $V_{Sx} = 13.2\text{ V}$	200	350	600	μs

BODY DIODE

Power Transistor Body Diode Forward Voltage	V_{bdFwd}	$I_f = 500\text{ mA}$	–	0.9	1.3	V
--	-------------	-----------------------	---	-----	-----	------------

NCV7718

ELECTRICAL CHARACTERISTICS ($-40^{\circ}\text{C} < T_J < 150^{\circ}\text{C}$, $5.5\text{ V} < V_{Sx} < 40\text{ V}$, $3.15\text{ V} < V_{CC} < 5.25\text{ V}$, $EN = V_{CC}$, unless otherwise specified)

Characteristic	Symbol	Conditions	Min	Typ	Max	Unit
----------------	--------	------------	-----	-----	-----	------

LOGIC INPUTS (EN, SI, SCLK, CSB)

Input Threshold High Low	VthInH VthInL		2.0 -	- -	- 0.6	V
Input Hysteresis (SI, SCLK, CSB)	VthInHys		50	150	300	mV
Enable Hysteresis	VthENHys		150	400	800	mV
Input Pull-down Resistance (EN, SI, SCLK)	Rpdx	$EN = SI = SCLK = V_{CC}$	50	125	200	k Ω
Input Pull-up Resistance (CSB)	RpuCSB	$CSB = 0\text{ V}$	50	125	250	k Ω
Input Capacitance	Cinx	Not ATE tested	-	--	15	pF

LOGIC OUTPUT (SO)

Output High	VsoH	$I_{SOURCE} = -1\text{ mA}$	$V_{CC} - 0.6$	-	-	V
Output Low	VsoL	$I_{SINK} = 1.6\text{ mA}$	-	-	0.4	V
Tri-state Leakage	ItriStLkg	$CSB = 5\text{ V}$	-5	-	5	μA
Tri-state Input Capacitance	ItriStCin	$CSB = V_{CC}$, $0\text{ V} < V_{CC} < 5.25\text{ V}$ Not ATE tested	-	-	15	pF

NCV7718

ELECTRICAL CHARACTERISTICS ($-40^{\circ}\text{C} < T_J < 150^{\circ}\text{C}$, $5.5\text{ V} < V_{Sx} < 40\text{ V}$, $3.15 < V_{CC} < 5.25\text{ V}$, $EN = V_{CC}$, unless otherwise specified)

Characteristic	Symbol	Conditions	Timing Chart	Min	Typ	Max	Unit
DRIVER OUTPUT TIMING SPECIFICATIONS							
High Side Turn On Time	T _{hsOn}	V _s = 13.2 V, R _{load} = 70 Ω		–	7.5	13	μs
High Side Turn Off Time	T _{hsOff}	V _s = 13.2 V, R _{load} = 70 Ω		–	3.0	6.0	μs
Low Side Turn On Time	T _{lsOn}	V _s = 13.2 V, R _{load} = 70 Ω		–	6.5	13	μs
Low Side Turn Off Time	T _{lsOff}	V _s = 13.2 V, R _{load} = 70 Ω		–	2.0	5.0	μs
High Side Rise Time	T _{hsTr}	V _s = 13.2 V, R _{load} = 70 Ω		–	4.0	8.0	μs
High Side Fall Time	T _{hsTf}	V _s = 13.2 V, R _{load} = 70 Ω		–	2.0	4.0	μs
Low Side Rise Time	T _{lsTr}	V _s = 13.2 V, R _{load} = 70 Ω		–	1.0	3.0	μs
Low Side Fall Time	T _{lsTf}	V _s = 13.2 V, R _{load} = 70 Ω		–	1.0	3.0	μs
High Side Off to Low Side On Non-Overlap Time	T _{hsOffLsOn}	V _s = 13.2 V, R _{load} = 70 Ω		1.5	–	–	μs
Low Side Off to High Side On Non-Overlap Time	T _{lsOffHsOn}	V _s = 13.2 V, R _{load} = 70 Ω		1.5	–	–	μs

SERIAL PERIPHERAL INTERFACE

SCLK Frequency	F _{clk}			–	–	5.0	MHz
SCLK Clock Period	T _{pClk}	V _{CC} = 5 V V _{CC} = 3.3 V		200 500	– –	– –	ns
SCLK High Time	T _{clkH}		1	85	–	–	ns
SCLK Low Time	T _{clkL}		2	85	–	–	ns
SCLK Setup Time	T _{clkSup}		3 4	85 85	– –	– –	ns
SI Setup Time	T _{siSup}		11	50	–	–	ns
SI Hold Time	T _{siH}		12	50	–	–	ns
CSB Setup Time	T _{csbSup}		5 6	100 100	– –	– –	ns
CSB High Time (Note 2)	T _{csbH}		7	5.0	–	–	μs
SO enable after CSB falling edge	T _{enSo}		8	–	–	200	ns
SO disable after CSB rising edge	T _{disSo}		9	–	–	200	ns
SO Rise Time	T _{soR}	C _{load} = 40 pF Not ATE tested	–	–	10	25	ns
SO Fall Time	T _{soF}	C _{load} = 40 pF Not ATE tested	–	–	10	25	ns
SO Valid Time	T _{soV}	C _{load} = 40 pF SCLK ↑ to SO 50%, Not ATE tested	10	–	20	50	ns
EN Low Valid Time	T _{enL}	V _{CC} = 5 V EN going low 50% to OUTx turning off 50%		10	–	–	μs
EN High to SPI Valid	T _{enHspiV}			–	–	100	μs
SRR Delay Between Two Consecutive Frame (Note 3)	T _{srr}			150	–	–	μs

2. This is the minimum time the user must wait between SPI commands

3. This is the minimum time the user must wait to send a SRR command between consecutive frames. If T_{srr} time is not met the SRR request is ignored.

ELECTRICAL CHARACTERISTIC TIMING DIAGRAMS

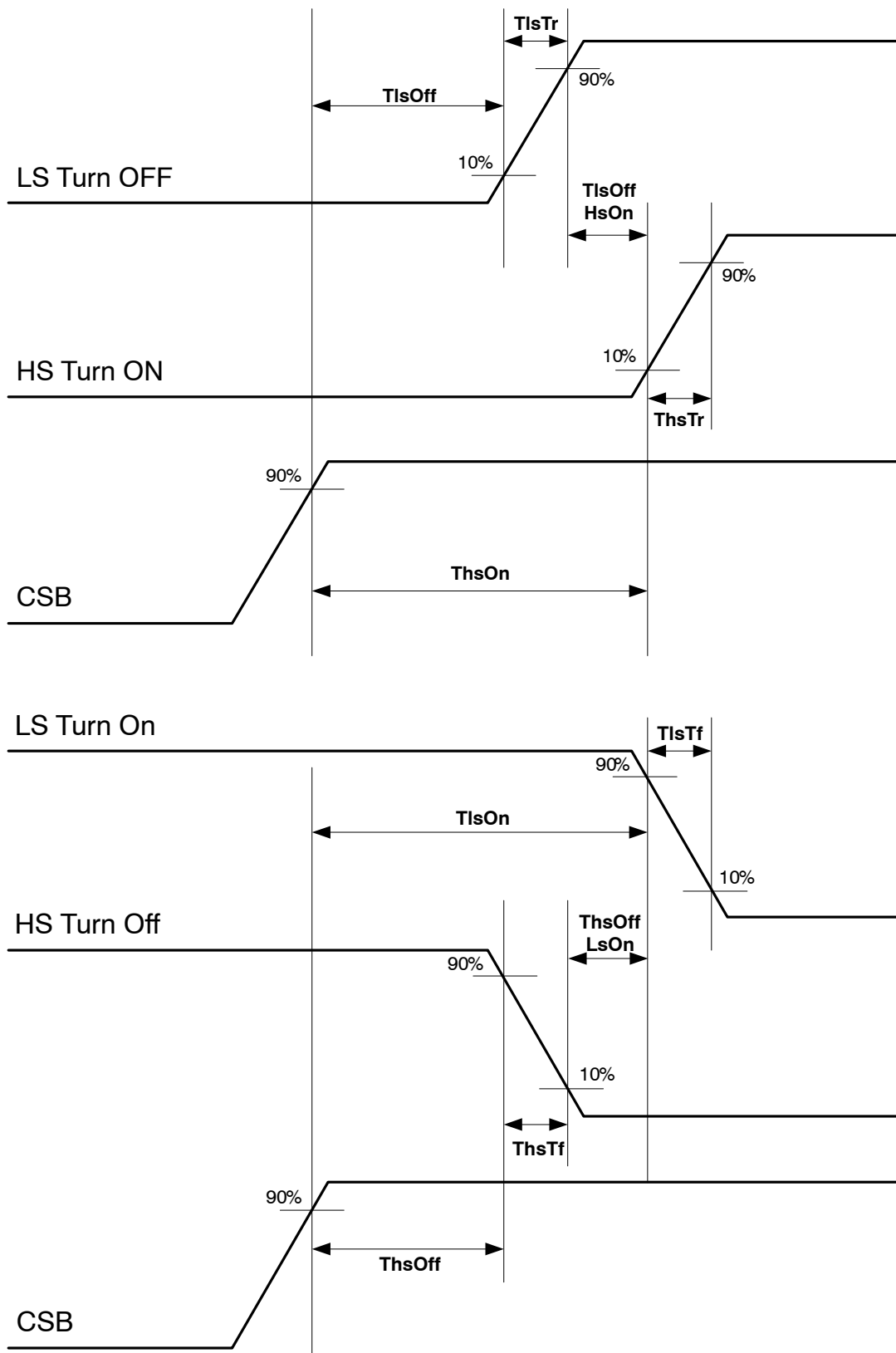

Figure 4. Detailed Driver Timing

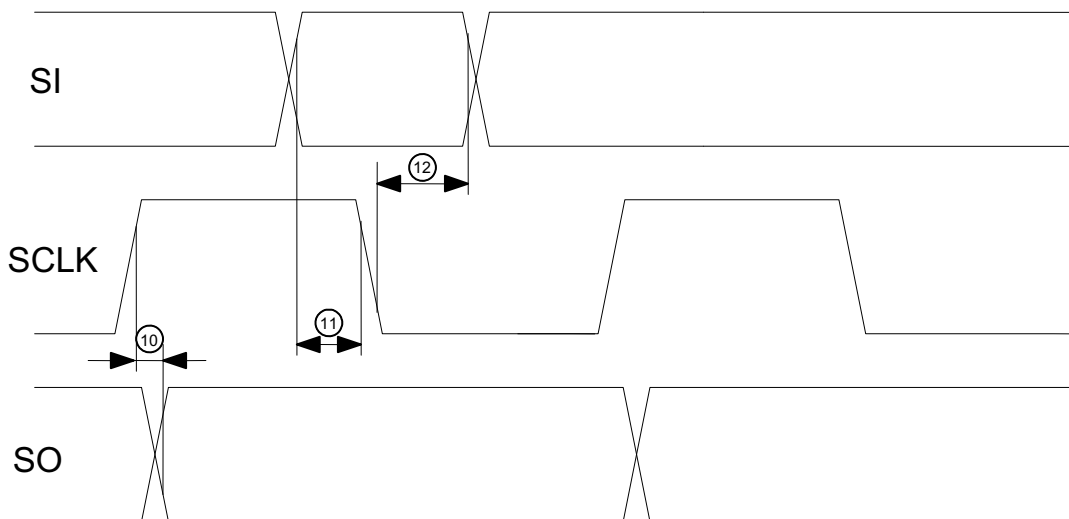
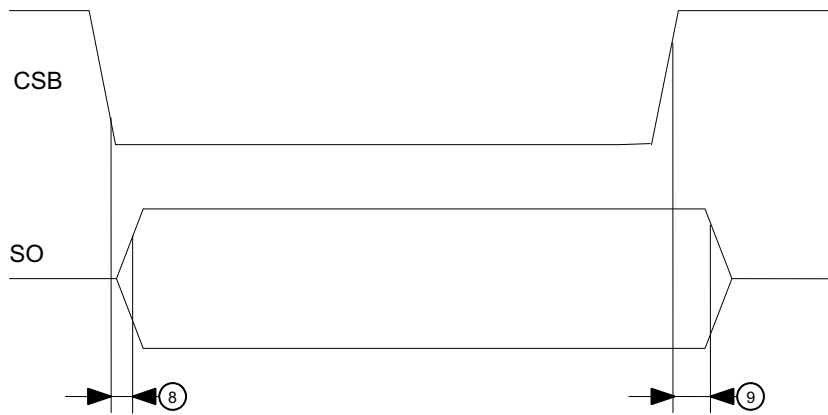
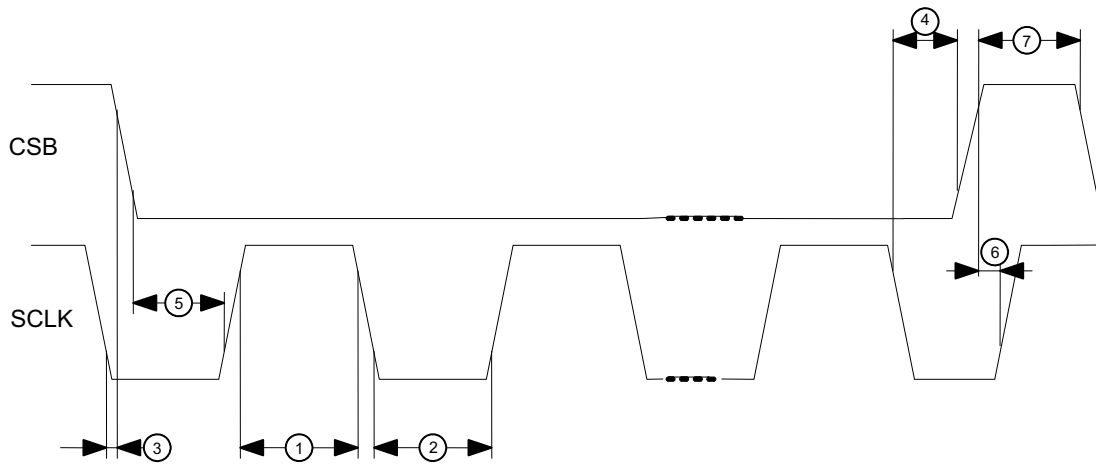

Figure 5. Detailed SPI Timing

TYPICAL PERFORMANCE GRAPHS

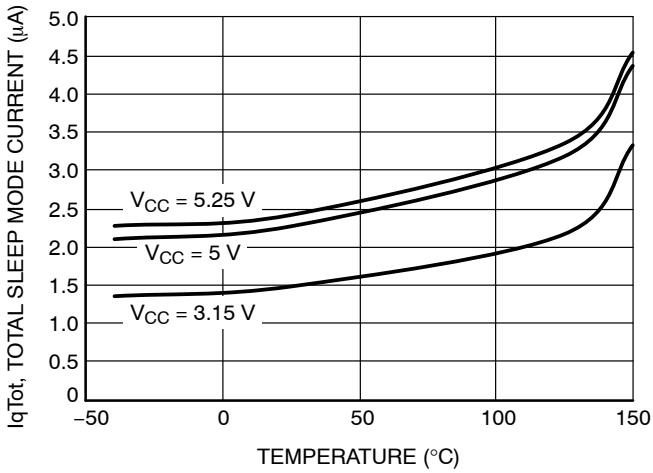

Figure 6. I_{qTot} vs. Temperature

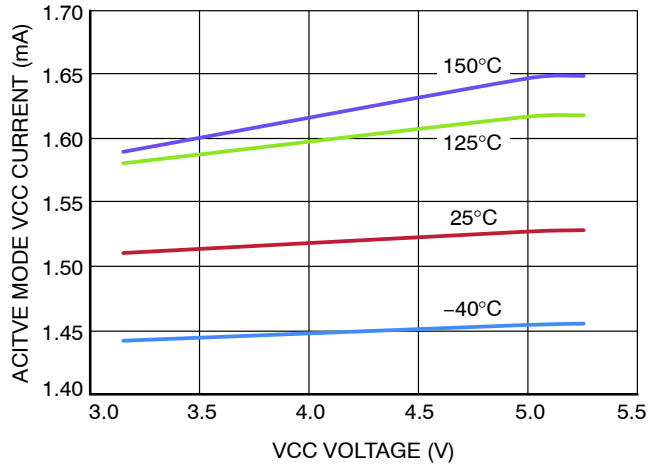

Figure 7. $I(V_{CC})$ Active Mode vs. $V(V_{CC})$

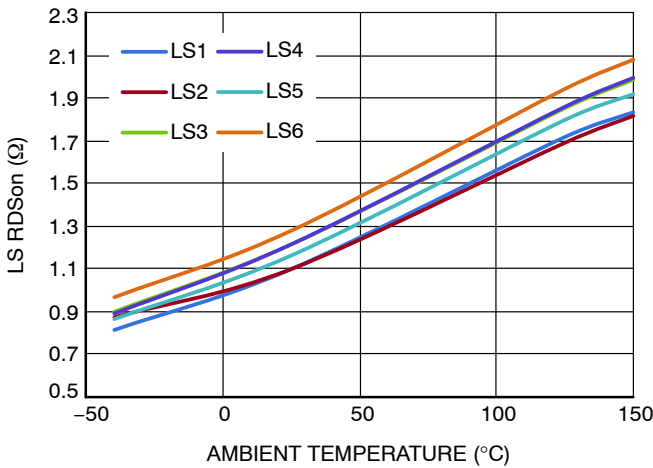

Figure 8. R_{DSonLs} vs. Temperature

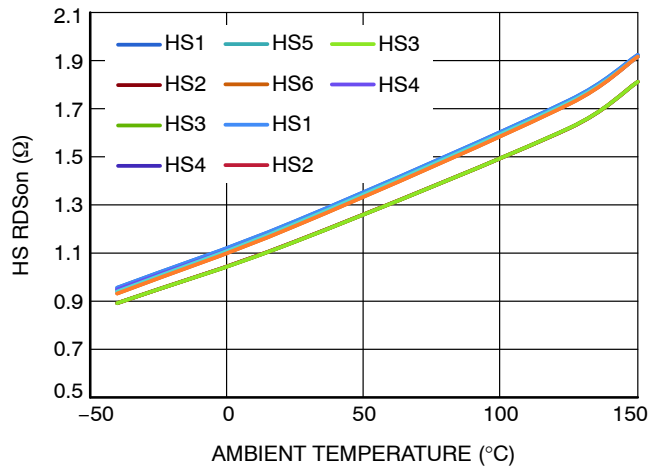

Figure 9. R_{DSonHs} vs. Temperature

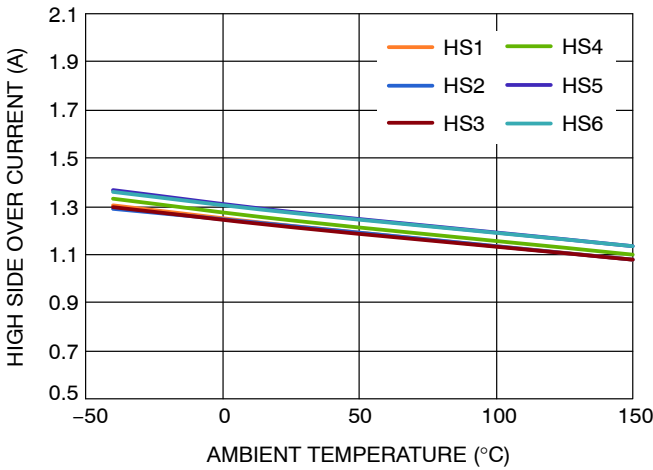

Figure 10. I_{sdSrc} vs. Temperature

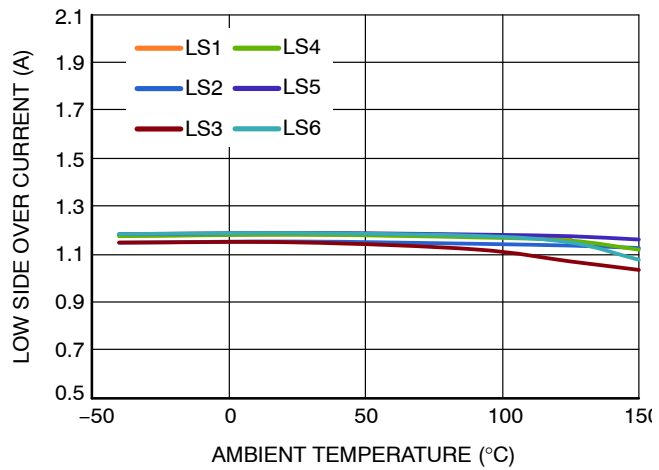

Figure 11. I_{sdSnk} vs. Temperature

TYPICAL PERFORMANCE GRAPHS

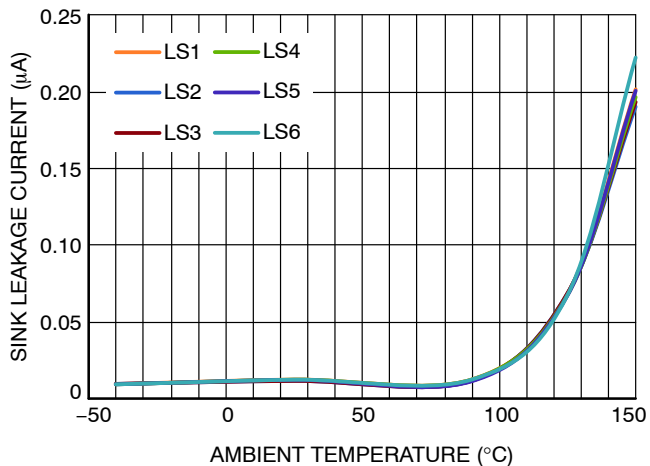

Figure 12. IsdSnk vs. Temperature

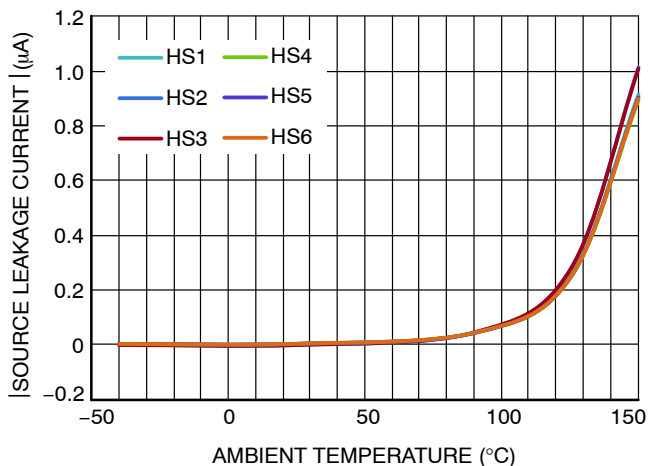

Figure 13. IsrcLkg13.2 vs. Temperature

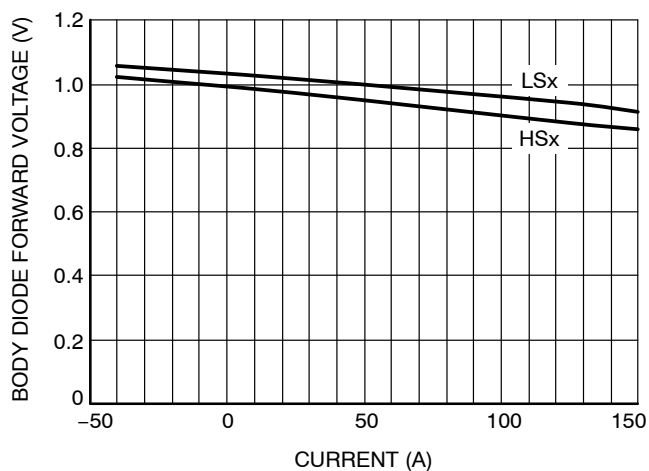

Figure 14. IbdFwd vs. Current

OPERATING DESCRIPTION

General Overview

The NCV7718 is comprised of twelve DMOS power drivers (six PMOS High Side Driver and six NMOS Low Side Driver) configured as six half bridges that enables three independent Full Bridge operations. Each output drive is characterized for a max 550 mA DC load and has a typical 1.2 A surge capability (at $V_{Sx} = 13.2$ V). Strict adherence to integrated circuit die temperature is necessary. Maximum die temperature is 150°C. This may limit the number of drivers enabled at one time. Output drive control and fault reporting is handled via the SPI (Serial Peripheral Interface) port.

An Enable function (EN) provides a low quiescent sleep current mode when the device is not being utilized. No data is stored when the device is in sleep mode. An internal pull down resistor is provided on the EN input to ensure the device is off if the input signal is lost. De-asserting the EN signal clears all the registers and resets the driver. When the EN signal is asserted the IC will proceed with the V_{CC} POR cycle and brings the drivers into normal operation.

SPI Communication

16-bit full duplex SPI communication has been implemented for the communication of this IC for device configurations, driver controls and reading the diagnostic data. In addition to the 16-bit diagnostic data, a pseudo bit (PRE_15) can also be retrieved from the SO register. The part is required to be enabled (EN active high) for SPI communication. The inputs for the SPI are TTL logic compatible and are specified by the V_{thInH} and V_{thInL} thresholds. The active low CSB input has a pull up resistor and the remaining SPI inputs have pull-down resistors to bias them to a known state when SPI is not active.

Reference the SPI communication frame format diagram in Figure 15 for the 16 bit SPI implementation. Tables 1 and 2 define the programming bits and diagnostic bits shown in Figure 15.

SPI COMMUNICATION FRAME FORMAT

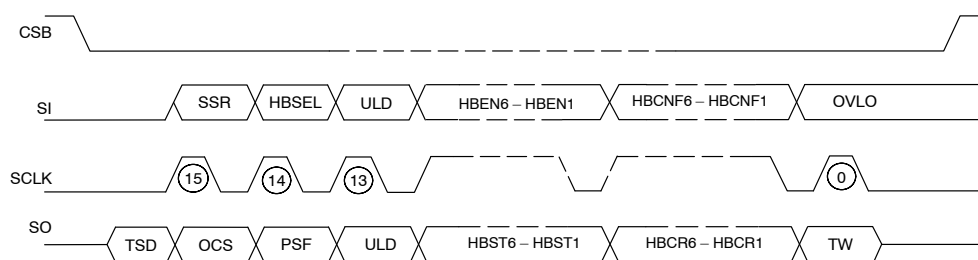

Figure 15. SPI Communication Frame Format

Communication is implemented as follows and is also illustrated in Figure 18:

1. SI and SCLK are set to low before the CSB cycle.
2. CSB goes low to allow serial data transfer.
3. SI data starting with the Most Significant bit (MSB) is shifted in first.
4. SI data is recognized on every falling edge of the clock.
5. Simultaneously, SO data from the previous frame starting with the MSB bit is shifted out on every rising edge of the clock.
6. The input data is compared to a 16 bit counter for the initial 16 bits shifted into SI for frame detection error scheme.
7. The sequential input bits are compared to a $n \times 8$ (n can take on the value of any integer) bit counter for daisy chain operations and are monitored by the frame detection error scheme.
8. CSB goes high and the most recent 16 bits clocked into SI are transferred to the data register given that there is no frame detection error. Otherwise the entire frame is ignored.
9. SO is tri-state when CSB is high.

NCV7718

Table 1. SPI INPUT DATA FRAME

Input Data			
Bit Number	Bit Name	Bit Description	Bit Status
15	SRR	Status Reset Register When Asserted All Latched Faults are Cleared (OCD, ULD & TSD)	0 = No Reset
			1 = Reset
14	HBSEL (Note 4)	Half Bridge Selection	Need to be set to zero
13	ULDSC	Under Load Detection Shutdown Control Global Enable; Per Half Bridge Operation	0 = Disable
			1 = Enable
12	HBEN6	Half Bridge 6 Enable	0 = High Z
			1 = Enabled
11	HBEN5	Half Bridge 5 Enable	0 = High Z
			1 = Enabled
10	HBEN4	Half Bridge 4 Enable	0 = High Z
			1 = Enabled
9	HBEN3	Half Bridge 3 Enable	0 = High Z
			1 = Enabled
8	HBEN2	Half Bridge 2 Enable	0 = High Z
			1 = Enabled
7	HBEN1	Half Bridge 1 Enable	0 = High Z
			1 = Enabled
6	HBCNF6	Half Bridge 6 Configuration Control	0 = LS6 ON & HS6 OFF
			1 = LS6 OFF & HS6 ON
5	HBCNF5	Half Bridge 5 Configuration Control	0 = LS5 ON & HS5 OFF
			1 = LS5 OFF & HS5 ON
4	HBCNF4	Half Bridge 4 Configuration Control	0 = LS4 ON & HS4 OFF
			1 = LS4 OFF & HS4 ON
3	HBCNF3	Half Bridge 3 Configuration Control	0 = LS3 ON & HS3 OFF
			1 = LS3 OFF & HS3 ON
2	HBCNF2	Half Bridge 2 Configuration Control	0 = LS2 ON & HS2 OFF
			1 = LS2 OFF & HS2 ON
1	HBCNF1	Half Bridge 1 Configuration Control	0 = LS1 ON & HS1 OFF
			1 = LS1 OFF & HS1 ON
0	OVLO	Over Voltage Lock Out Global Effect	0 = Disable
			1 = Enable

4. HBSEL enables bridge selection for the NCV7719 and NCV7720 devices. In the NCV7718 if the HBSEL is set to '1' then the entire frame is ignored.

Table 2. SPI OUTPUT DATA FRAME

Output Data			
Bit Number	Bit Name	Bit Description	Bit Status
PRE_15	TSD	Latched Thermal Shutdown	0 = No Fault
			1 = Fault
15	OCS	Over Current Shutdown Global Notification	0 = No Fault
			1 = Fault
14	PSF	Power Supply Failure on VS1 and/or VS2 Under Voltage and Over Voltage Monitoring	0 = No Fault
			1 = Fault
13	ULD	Under Load Detection Global Notification	0 = No Fault
			1 = Fault
12	HBST6	Half Bridge 6 Enable Status	0 = High Z
			1 = Enabled
11	HBST5	Half Bridge 5 Enable Status	0 = High Z
			1 = Enabled
10	HBST4	Half Bridge 4 Enable Status	0 = High Z
			1 = Enabled
9	HBST3	Half Bridge 3 Enable Status	0 = High Z
			1 = Enabled
8	HBST2	Half Bridge 2 Enable Status	0 = High Z
			1 = Enabled
7	HBST1	Half Bridge 1 Enable Status	0 = High Z
			1 = Enabled
6	HBCR6	Half Bridge 6 Configuration Reporting	0 = LS6 ON & HS6 OFF
			1 = LS6 OFF & HS6 ON
5	HBCR5	Half Bridge 5 Configuration Reporting	0 = LS5 ON & HS5 OFF
			1 = LS5 OFF & HS5 ON
4	HBCR4	Half Bridge 4 Configuration Reporting	0 = LS4 ON & HS4 OFF
			1 = LS4 OFF & HS4 ON
3	HBCR3	Half Bridge 3 Configuration Reporting	0 = LS3 ON & HS3 OFF
			1 = LS3 OFF & HS3 ON
2	HBCR2	Half Bridge 2 Configuration Reporting	0 = LS2 ON & HS2 OFF
			1 = LS2 OFF & HS2 ON
1	HBCR1	Half Bridge 1 Configuration Reporting	0 = LS1 ON & HS1 OFF
			1 = LS1 OFF & HS1 ON
0	TW	Thermal Warning Global Notification	0 = No Fault
			1 = Fault

If the half-bridge enable status denotes a high impedance condition (HBSTx = 0), the corresponding half-bridge configuration reporting (HBCRx) should be ignored. The

1. SCLK and SI are low before the CSB cycle. Violating these conditions will result in an undetermined SPI behavior or/and an incorrect TSD reading.
2. CSB transitioning from high to low.
3. CSB setup time (TcsbSup) is satisfied and the data is captured before the first SCLK rising edge.

latched thermal shutdown (TSD) information is available on SO after CSB goes low until the first rising SCLK edge. The following procedures must be met for a true TSD reading:

NCV7718

Driver Control

The NCV7718 has the flexibility of controlling each driver through the 16 bit SPI frame (Bits 12–1) and the logic

combination required for bridge control is defined in Figure 16.

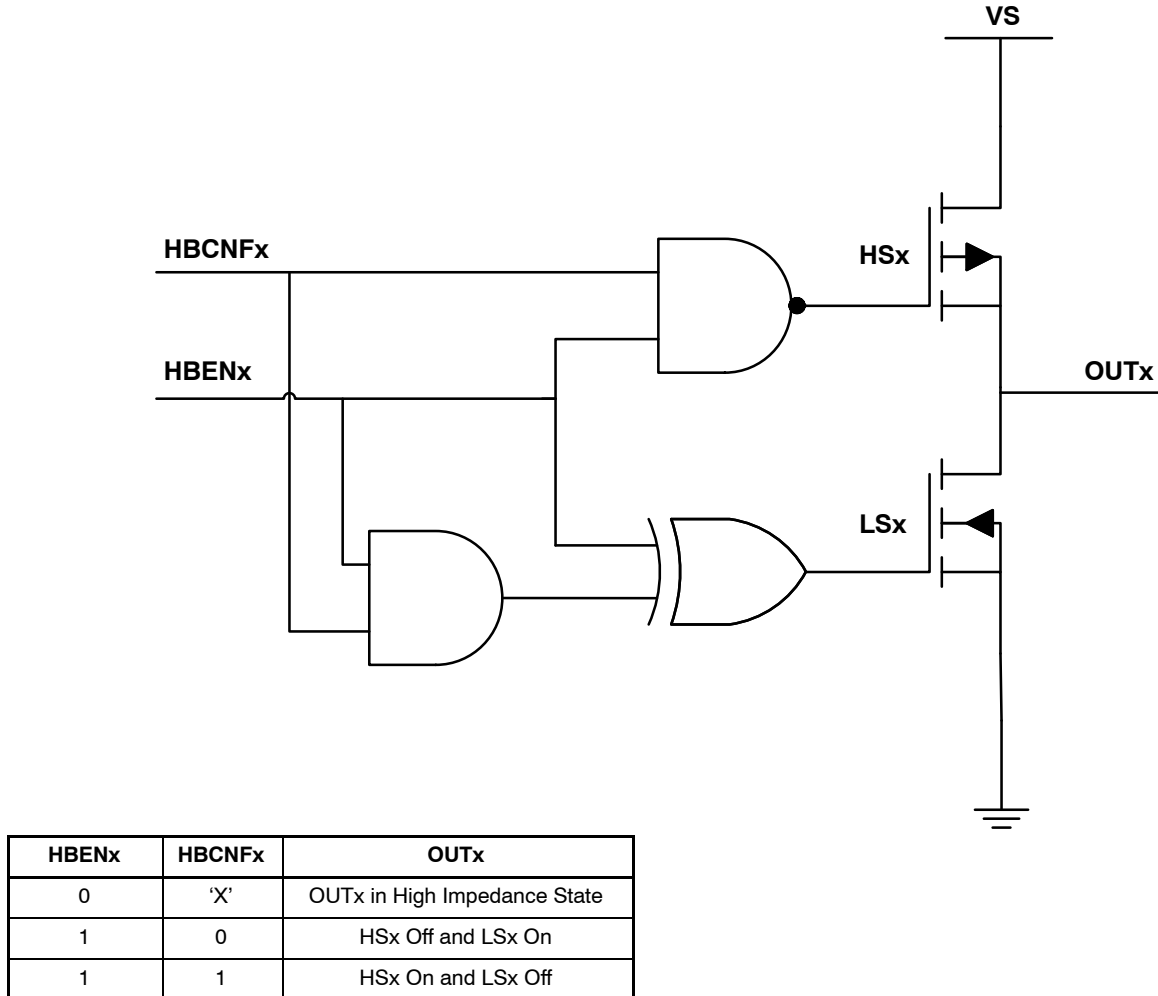

'X' = Don't Care

Figure 16. Bridge Control Logic

The digital design insures that the high side and low side of the same half bridge will not be active at the same time. Thus the device self protects from a current shoot through condition. Delays (T_{hsOffLsOn} and T_{lsOffHsOn}) between the high side and low side switching are implemented for same reasons.

Frame Detection

To maintain the data integrity, the NCV7718 has 16 bit frame detection. A valid frame for a single CSB cycle requires 16 bits to be clocked into SI for the initial 16 bits and $n \times 8$ bits thereafter. In an instance of an invalid SPI frame the entire frame is ignored, but the previous states of the corresponding outputs are maintained.

Daisy Chain Operation

Daisy chain communications between multiple of 8-bit SPI compatible IC's is possible by connection of the serial output pin (SO) to the input of the sequential IC (SI). The clock phase and clock polarity respect to the data must be the same for all the devices on the chain. Figure 17 illustrates the hardware configuration of NCV7718 daisy chained with a $n \times 8$ bit (ie $n = 2$; 16 bit) SPI device. The progression of data from the MCU through the sequential devices is also shown. Strict adherence to the frame format illustrated in Figure 18 is required for the proper serial daisy chain operations.

NCV7718

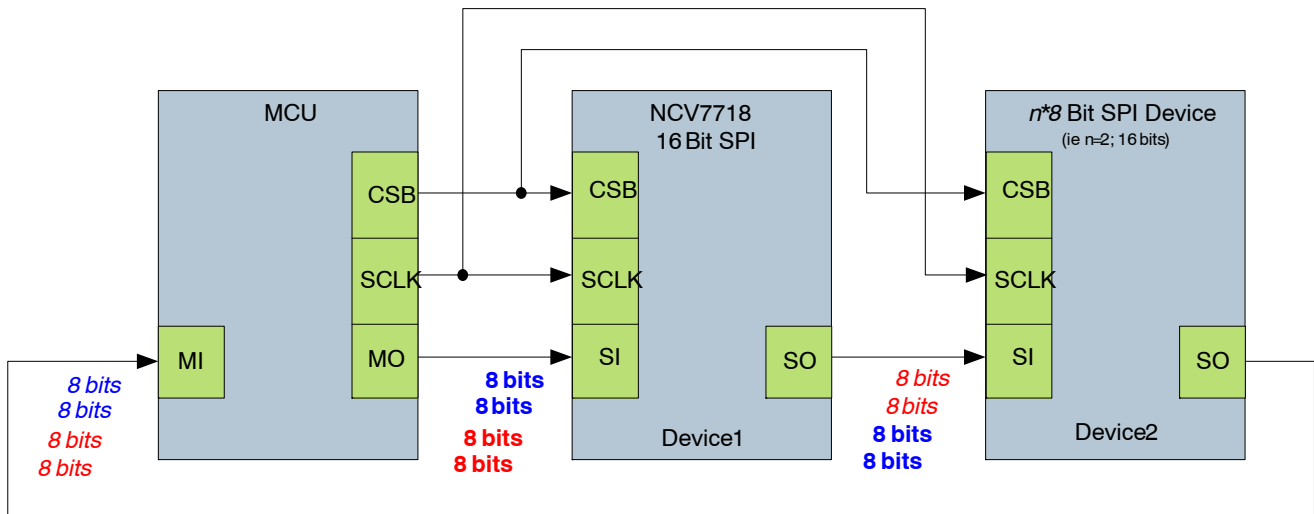

Command Bits for the Device 2

Previous Diagnostic Bits from Device2

Command Bits for Device 1

Previous Diagnostic Bits From Device1

Figure 17. Serial Daisy Chain

If Device 2 is a 16 bit IC, then a total of 32 bits must be generated from the MCU for a complete transport of data in the system. Monitoring of all the devices in the serial chain must be employed on a system level architecture. Thus, pre-cautious measure should be taken to avoid situations where not enough frames were sent to the devices, but the frames transmitted did not violate the internal frame

detection counters. For these scenarios, invalid data is accepted by NCV7718 and possibly by other devices on the chain depending on their frame detection design. The data shifted in will be transferred to the data registers of the devices on the beginning of the chain and the devices at the end of the chain will get the previous diagnostic data of the preceding devices.

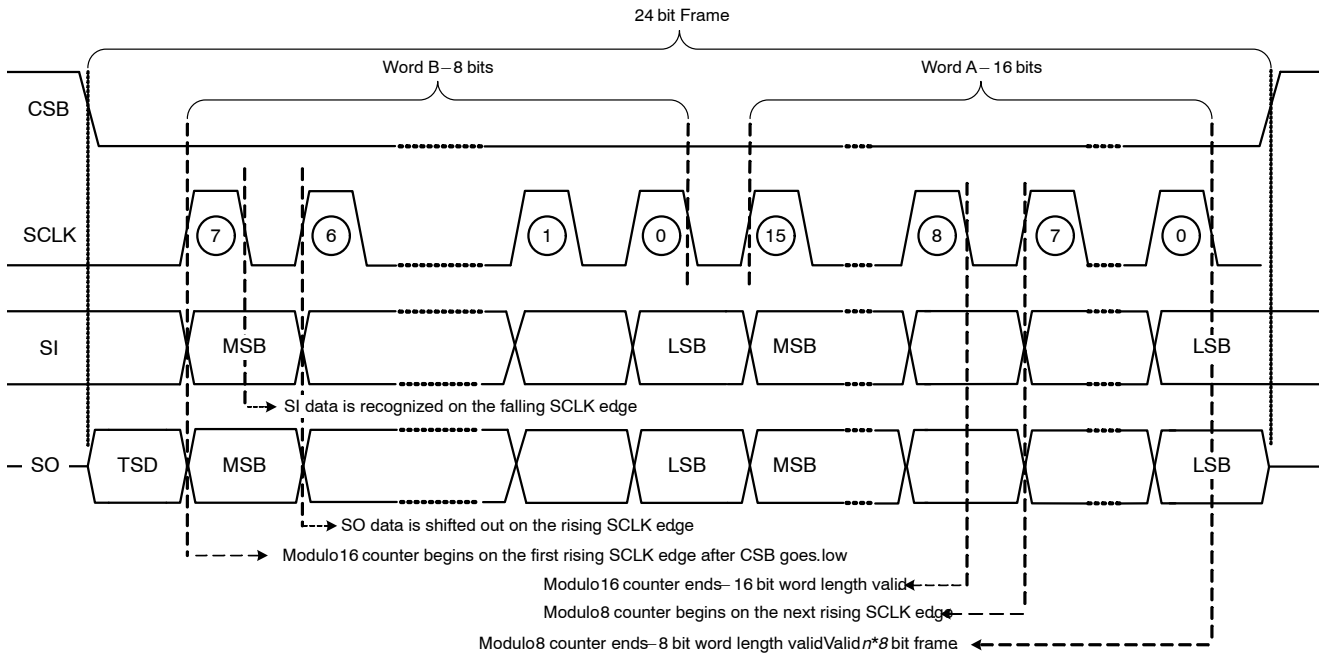

Figure 18. SPI Data Recognition and Frame Detection

The TSD bit is multiplexed with the SPI SO data and OR'd with the SI input (Figure 19) to allow for reporting in a serial daisy chain configuration in devices with the same SPI protocol. A TSD error bit as a "1" automatically propagates through the serial daisy chain circuitry from the SO output

of one device to the SI input of the next. This is shown in Figures 20 and 21; first as the daisy chained devices connected with no thermal shutdown latched fault (Figure 20) and subsequently with a TSD fault in device 1 propagating through to device 2 (Figure 21).

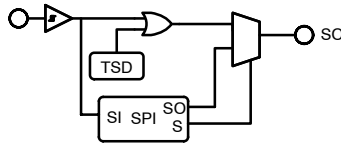

Figure 19. TSD SPI Link

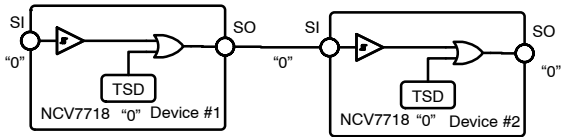

Figure 20. Daisy Chain No TSD Fault

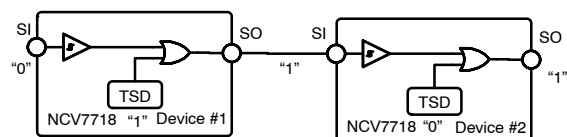

Figure 21. Daisy Chain TSD Error Propagation

DEVICE PROTECTION, DIAGNOSTICS AND FAULT REPORTING

Power Up/Down Control

Each analog power pin (VS1 or VS2) powers their respective output drivers. After a device has powered up and the output drivers are allowed to turn on, the output drivers will not turn off until the voltage on the supply pins is reduced below the initial under voltage threshold, exceeds the over voltage threshold or if shut down by either a SPI command or a fault condition.

Internal power-up circuitry on the logic supply pin supports a smooth turn on transition. VCC power up resets the internal logic such that all output drivers will be off as power is applied. All the internal counters, SI and SO along with all the digital registers will be cleared on VCC POR. Exceeding the under voltage lockout threshold on VCC allows information to be input through the SPI port for turn on control. Logic information remains intact over the entire VS1 and VS2 voltage range.

provided by monitoring the voltages on the VS1, VS2 and VCC pins. A built-in hysteresis on the under voltage threshold is included to prevent an unknown region on the power pins; VCC, VS1 and VS2. When the VCC goes below the threshold, all outputs are turned off and the input and output registers are cleared.

An under voltage condition on the VSx pins will result in shutting off all the drivers and the status bit 14 (PSF) will be set. The SPI port remains active during a VSx under-voltage if proper VCC voltage is supplied. Also all driver states will be maintained in the logic circuitry with the valid VCC voltage. Once the input voltage VSx is above the under voltage threshold level the drivers will return to programmed operation and the PSF output register bit is cleared.

Under-voltage timing diagram is provided in Figure 22.

Under Voltage Shutdown

An under voltage lockout circuit prevents the output drivers from turning on unintentionally. This control is

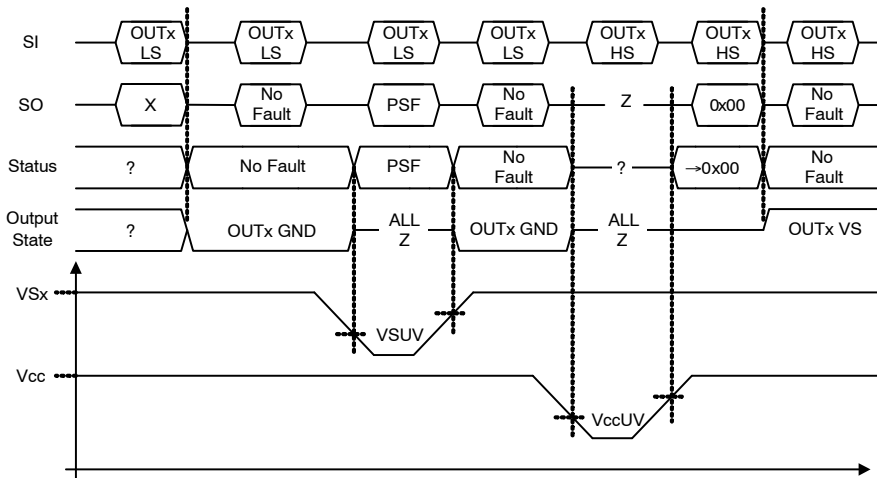

Figure 22. Under-Voltage Timing Diagram

Over Voltage Shutdown

Over voltage shutdown circuitry monitors the voltage on the VS1 and VS2 pins, which permits a 40 V maximum. When the Over-voltage Threshold level has been breached on the VS1 or VS2 supply input, the output bit 14 (PSF) will be set. Additionally, if the input bit 0 (OVLO) is asserted, all outputs will turn off. During an Over Voltage Lockout condition the turn on/off status is maintained in the logic circuitry. When proper input voltage levels are

re-established, the programmed outputs will turn back on. Over-voltage shutdown can be disabled by using the SPI input bit 0 (OVLO = 0) to run through a load dump situation. It is highly recommended to operate the part with OVLO bit asserted to ensure that the drivers remain off during a load dump scenario.

The table below describes the driver status when enabling/disabling the over voltage lock out feature during normal and overvoltage situations.

Table 3. OVER-VOLTAGE LOCK OUT (OVLO)

OVLO Input Bit	VSx OVLO Condition	Output Data Bit 14 Power Supply Fail (PSF) Status	OUTx Status
0	0	'0'	Not in Overvoltage Outputs Unchanged
0	1	'1' (Clears when VSx within Operating Range)	In Overvoltage → Outputs Unchanged
1	0	'0'	Not in Overvoltage Outputs Unchanged
1	1	'1' (Clears when VSx within Operating Range)	All Outputs Off (Remain off until VSx is out of OVLO)

Over-voltage timing diagram is provided in Figure 23.

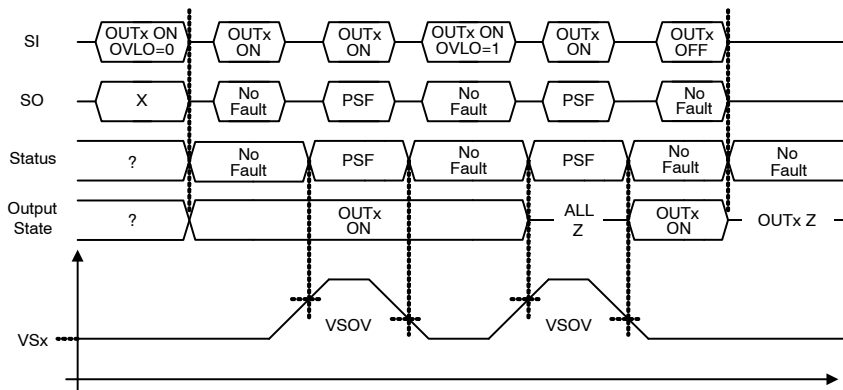

Figure 23. Over-Voltage Timing Diagram

Over Current Detection and Shutdown

The NCV7718 offers over current shutdown protection on the OUTx pins by monitoring the current on the high side and low side drivers. If the over current threshold is breached, the corresponding output is latched off (HS and LS driver is latched off) after the specified shutdown time, TdOc. Upon over current shutdown, the serial output bit OCS will be set to denote a high power dissipation state. Devices can be turned back on via the SPI port once the OCS

bit is cleared by setting the SRR to '1' on the next SPI command. The event triggering the over current shutdown condition must be resolved prior to clearing the OCS bit to avoid repetitive stress on the drivers. Failure to do so may result in non reversible fatal damage.

Note: high currents could cause a high rise in die temperature. Devices will turn off if the die temperature exceeds the thermal shutdown temperature.

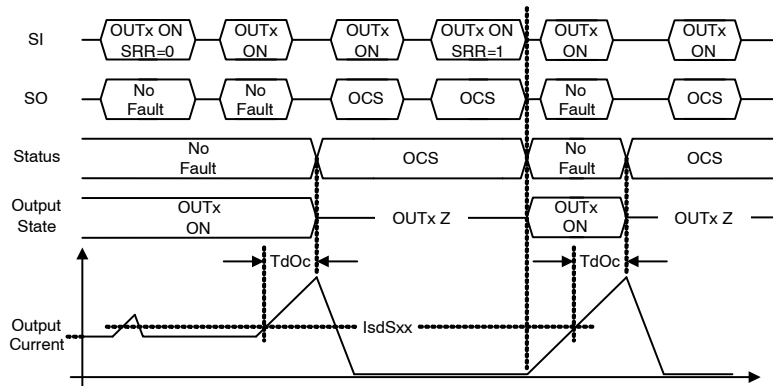

Figure 24. Over-Current Timing Diagram

Under Load Detection

The under-load detection is accomplished by monitoring the current from the low side drivers and one global output bit is used for under load fault reporting. A minimum load current (IuldLS – this is the maximum open circuit detection threshold) is required when the drivers are turned on to avoid an under-load condition. If the under-load detection threshold has been breached longer than the specified

under-load timer (TdUld), the ULD output bit is set to '1'. Furthermore, if the Under-Load Detection Shutdown Control (ULDSC bit # 13) input bit is set then the offending half-bridge output will be turned off (HS and LS on the driver will be latched off). There is only one global under load timer for all the drivers. If the TdUld timer is already activated due to one under load, any subsequent under load delays will be the remainder of the TdUld timer.

Table 4. UNDER-LOAD DRIVER STATUS

ULDSC Input Bit 13	OUTx ULD Condition	Output Data Bit Under Load Detect Status	OUTx Status
0	0	'0'	Unchanged
0	1	'1' (Need SRR to reset)	Unchanged
1	0	'0'	Unchanged
1	1	'1' (Need SRR to reset)	OUTx Latches off (Need SRR to reset)

Under-load timing diagram is provided in Figure 25.

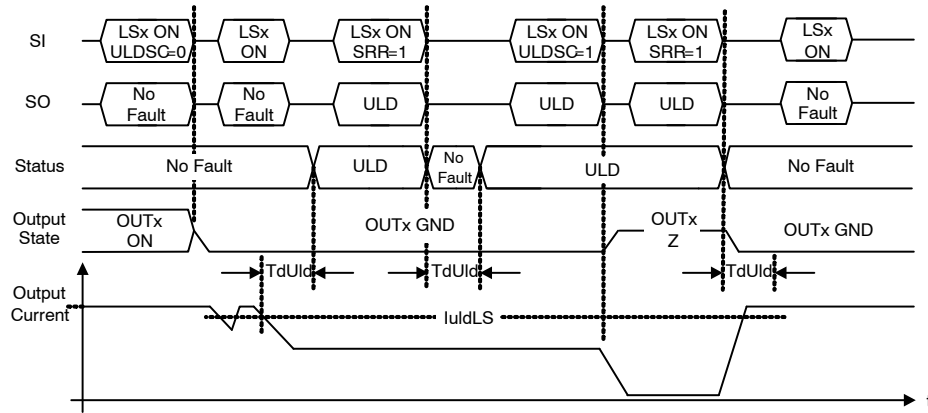

Figure 25. Under-load Timing Diagram

Thermal Warning and Thermal Shutdown

The NCV7718 provides individual thermal sensors for each half-bridge. Moreover, the sensor reports over temperature warning level and an over temperature shutdown level. The TW status bit (output bit 0) will be set if the temperature exceeds the over temperature warning level, but the drivers will remain active. Once the IC temperature fall below the thermal warning threshold the TW flag is automatically cleared. If any of the individual

thermal sensors detects a thermal shutdown level then the drivers on the offending half bridge are latched off. The TSD (PRE_15) bit is set to capture a thermal shutdown event. A valid SPI command with SRR and temperature below the Tsd threshold are required to clear the latched fault. Since thermal warning precedes an over temperature shutdown, software polling of this bit will allow load control and possible prevention of over temperature shutdown conditions.

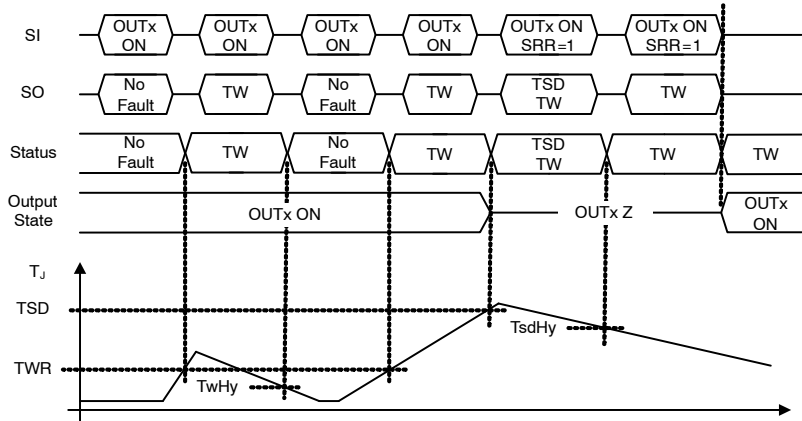

Figure 26. Thermal Warning and Shutdown Timing Diagram

Thermal Performance

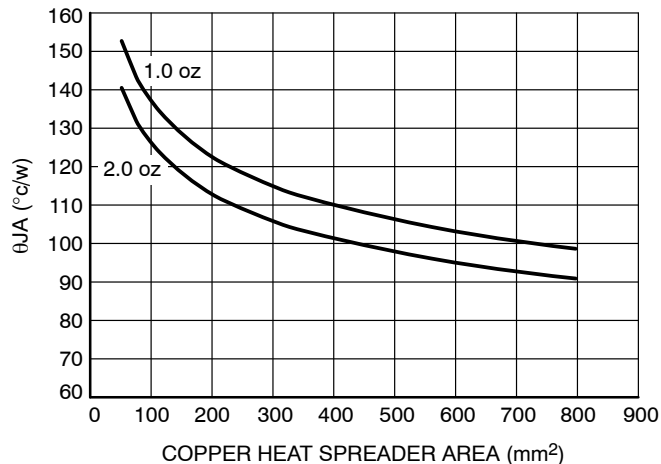

Figure 27. θ_{JA} vs. Cu Area

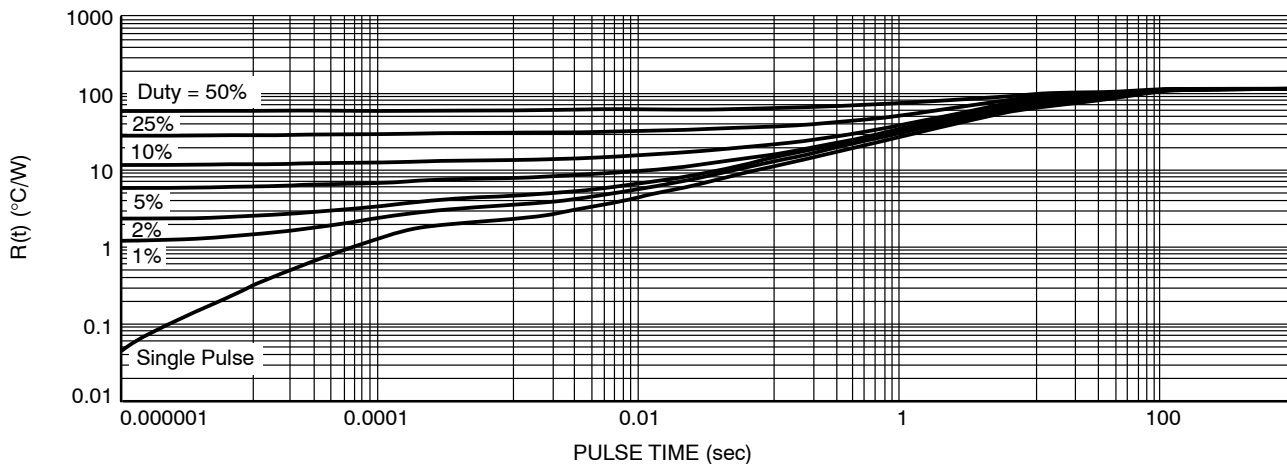

Figure 28. $R(t)$ vs. Duty Cycle on 600 mm² Spreader Area over 2 oz Copper

Table 5. SSOP24 THERMAL RC NETWORK MODELS

Foster Thermal Network				Cauer Thermal Network			
200 mm ²		900 mm ²		200 mm ²		900 mm ²	
R	C	R	C	R	C	R	C
°C/W	W-sec/C	°C/W	W-sec/C	°C/W	W-sec/C	°C/W	W-sec/C
2.00E-02	5.00E-05	2.00E-02	5.00E-05	1.49E-01	1.74E-05	1.49E-01	1.74E-05
2.00E-01	5.00E-05	2.00E-01	5.00E-05	5.67E-01	1.27E-05	5.67E-01	1.27E-05
1.70E+00	5.88E-05	1.70E+00	5.88E-05	1.32E+00	4.19E-05	1.32E+00	4.19E-05
1.20E+00	2.92E-03	1.20E+00	2.92E-03	2.55E+00	1.94E-03	2.55E+00	1.94E-03
2.70E+00	8.52E-03	2.70E+00	8.52E-03	4.90E+00	5.08E-03	4.88E+00	5.09E-03
3.50E+00	3.43E-02	3.50E+00	3.43E-02	1.10E+01	1.44E-02	1.08E+01	1.45E-02
7.40E+00	5.95E-02	7.40E+00	5.95E-02	1.58E+01	2.84E-02	1.53E+01	2.91E-02
2.32E+01	9.05E-02	2.32E+01	9.05E-02	2.12E+01	6.53E-02	1.97E+01	6.90E-02
2.71E+01	3.69E-01	2.71E+01	3.69E-01	2.59E+01	3.66E-01	1.93E+01	4.45E-01
4.59E+01	1.53E+00	2.24E+01	3.13E+00	2.95E+01	1.78E+00	1.48E+01	4.05E+00

The Cauer networks generally have physical significance and may be divided between nodes to separate thermal behavior due to one portion of the network from another. The Foster networks, though when sorted by times constant (as above) bear a rough correlation with the Cauer networks, are really only convenient mathematical models. Both Foster and Cauer networks can be easily implemented using

circuit simulating tools, whereas Foster networks may be more easily implemented using mathematical tools (for instance, in a spreadsheet program), according to the following formula:

$$R(t) = \sum_{i=1}^n R_i \left(1 - e^{-\frac{t}{\tau_i}} \right)$$

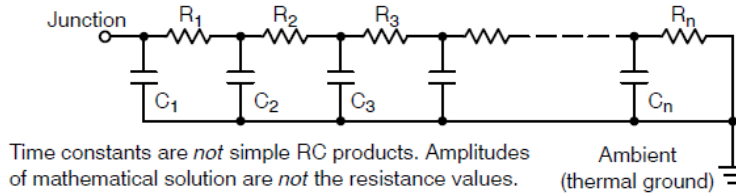

Figure 29. Grounded Capacitor Network (“Cauer” Ladder”)

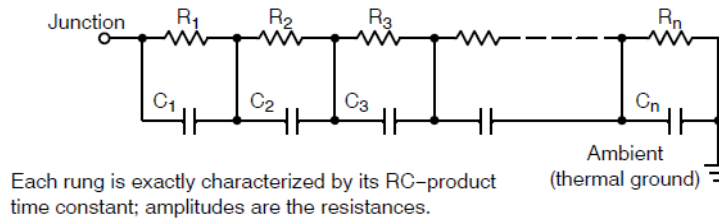

Figure 30. Non-Grounded Capacitor Network (“Foster” Ladder”)

Fault Handling

At an event of a driver latched off fault, the offending half-bridge driver is disabled and the half-bridge configuration is defaulted to zero (HBENx =0, HBCNFx = 0). The user is required to clear the output register fault and to resend the proper SPI frame to turn on the drivers. A driver

that is locked out during a fault conditions auto recovers to the previous programmed state when the fault is resolved. A latched fault flag on the serial output doesn't always translate an output latched off fault.

The summary of all fault conditions, the driver status and the clear requirements are provided in Table 6.

Table 6. FAULT SUMMARY

Fault	Fault Memory Serial Output Bit	Driver Condition During Fault	Driver Condition after Parameters Within Specified Limits	Output Register Clear Requirement
Under Load (ULDSC = 0)	Latched	Outputs Unchanged. Allowed to turn/ remain on	Allowed to turn/remain on	Valid SPI frame with SRR set to 1
Under Load (ULDSC = 1)	Latched (Note 5)	Offending Half-Bridge is Latched Off (LS and HS)	Offending Half-Bridge is Latched Off (LS and HS)	Valid SPI frame with SRR set to 1
Over Current	Latched (Note 5)	Offending Output is Latched Off (LS and HS)	Offending Output is Latched Off (LS and HS)	Valid SPI frame with SRR set to 1
Thermal Warning	Non-Latched	Outputs Unchanged. Allowed to turn/ remain on provided that device is not in thermal shutdown	Allowed to turn/remain on	Temp below (thermal warning temp – hysteresis)
Thermal Shutdown	Latched (Note 5)	Offending Half-Bridge Drivers are Latched Off (LS and HS)	Offending Half-Bridge is Latched Off (LS and HS)	Valid SPI frame with SRR set to 1. Temperature blow (thermal shutdown – hysteresis)
VS Power Supply Fail (Over-Voltage: OVLO = 0)	Non-Latched	Outputs Unchanged. Allowed to turn/ remain on	Allowed to turn/remain on	VS below (Over Voltage Threshold – hysteresis)
VS Power Supply Fail (Over-Voltage: OVLO = 1)	Non-Latched	All Drivers are Locked Out. Outx → High Z	Previous Half-Bridge status and driver configuration is maintained. Allowed to turn/remain on	Auto Recovers if the VS voltage is below overvoltage threshold
VS Power Supply Fail (Under Voltage)	Non-Latched	All Drivers are Locked Out. Outx → High Z	Previous Half-Bridge status and driver configuration is maintained. Allowed to turn/remain on	Auto Recovers if the VS voltage is above the Under Voltage threshold

5. Latched conditions are cleared via the SPI SRR input bit = 1, by cycling the EN pin or with a power-on reset of V_{CC}.

NCV7718

APPLICATION DIAGRAM

The application drawing below demonstrates the drive capability of the NCV7718. The VS1 and VS2 pins must be

tied together to avoid any potential difference in the supply voltage.

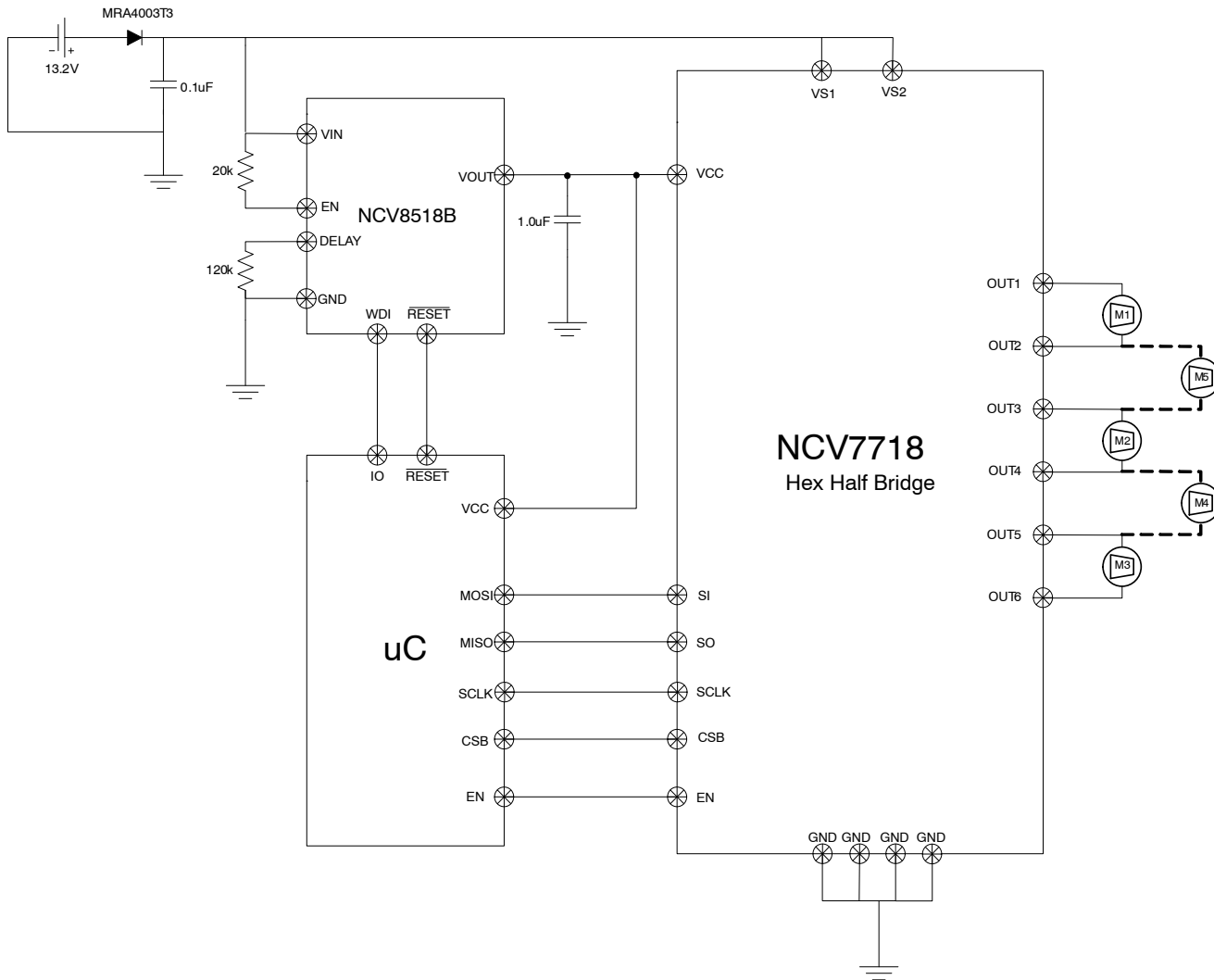

Figure 31. Application Drawing

ORDERING INFORMATION

Device	Package	Shipping [†]
NCV7718DPR2G	SSOP24 (Pb-Free)	2500 / Tape & Reel

[†]For information on tape and reel specifications, including part orientation and tape sizes, please refer to our Tape and Reel Packaging Specifications Brochure, BRD8011/D.

NCV7718

PACKAGE DIMENSIONS

SSOP24 NB
CASE 565AL-01
ISSUE O

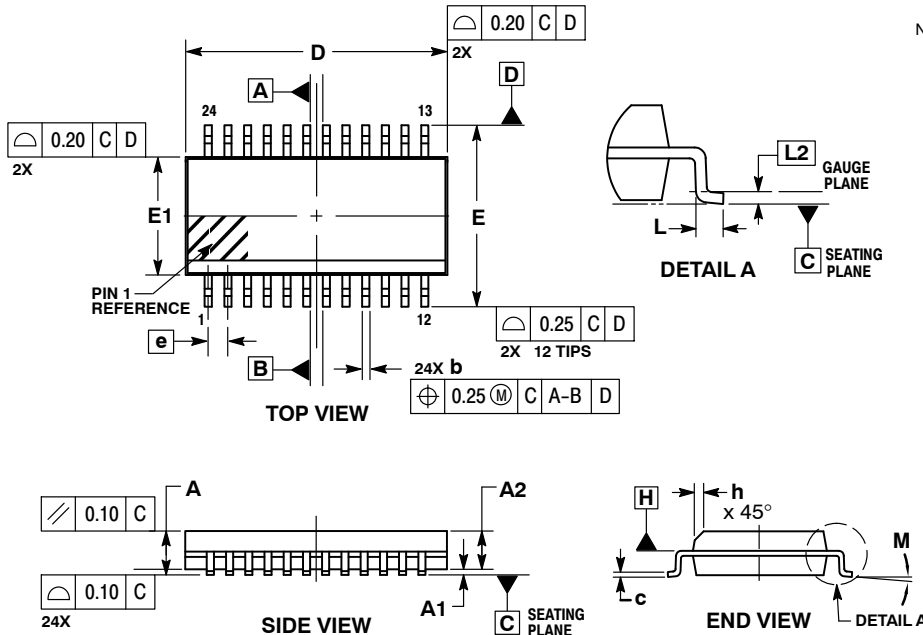

NOTES:

1. DIMENSIONING AND TOLERANCING PER ASME Y14.5M, 1994.
2. CONTROLLING DIMENSION: MILLIMETERS.
3. DIMENSION b DOES NOT INCLUDE DAMBAR PROTRUSION.
4. DIMENSION D DOES NOT INCLUDE MOLD FLASH, PROTRUSIONS OR GATE BURRS. MOLD FLASH, PROTRUSIONS OR GATE BURRS SHALL NOT EXCEED 0.15 PER SIDE. DIMENSION E1 DOES NOT INCLUDE INTERLEAD FLASH OR PROTRUSION. INTERLEAD FLASH OR PROTRUSION SHALL NOT EXCEED 0.15 PER SIDE. D AND E1 ARE DETERMINED AT DATUM H.
5. DATUMS A AND B ARE DETERMINED AT DATUM H.

DIM	MILLIMETERS	
	MIN	MAX
A	1.35	1.75
A1	0.10	0.25
A2	1.25	1.50
b	0.20	0.30
c	0.19	0.25
D	8.65 BSC	
E	6.00 BSC	
E1	3.90 BSC	
e	0.65 BSC	
h	0.22	0.50
L	0.40	1.27
L2	0.25 BSC	
M	0°	8°

RECOMMENDED SOLDERING FOOTPRINT*

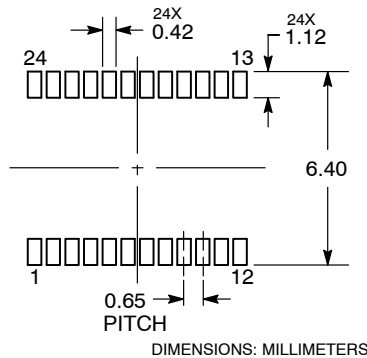

*For additional information on our Pb-Free strategy and soldering details, please download the ON Semiconductor Soldering and Mounting Techniques Reference Manual, SOLDERRM/D.

ON Semiconductor and are registered trademarks of Semiconductor Components Industries, LLC (SCILLC). SCILLC owns the rights to a number of patents, trademarks, copyrights, trade secrets, and other intellectual property. A listing of SCILLC's product/patent coverage may be accessed at www.onsemi.com/site/pdf/Patent-Marking.pdf. SCILLC reserves the right to make changes without further notice to any products herein. SCILLC makes no warranty, representation or guarantee regarding the suitability of its products for any particular purpose, nor does SCILLC assume any liability arising out of the application or use of any product or circuit, and specifically disclaims any and all liability, including without limitation special, consequential or incidental damages. "Typical" parameters which may be provided in SCILLC data sheets and/or specifications can and do vary in different applications and actual performance may vary over time. All operating parameters, including "Typicals" must be validated for each customer application by customer's technical experts. SCILLC does not convey any license under its patent rights nor the rights of others. SCILLC products are not designed, intended, or authorized for use as components in systems intended for surgical implant into the body, or other applications intended to support or sustain life, or for any other application in which the failure of the SCILLC product could create a situation where personal injury or death may occur. Should Buyer purchase or use SCILLC products for any such unintended or unauthorized application, Buyer shall indemnify and hold SCILLC and its officers, employees, subsidiaries, affiliates, and distributors harmless against all claims, costs, damages, and expenses, and reasonable attorney fees arising out of, directly or indirectly, any claim of personal injury or death associated with such unintended or unauthorized use, even if such claim alleges that SCILLC was negligent regarding the design or manufacture of the part. SCILLC is an Equal Opportunity/Affirmative Action Employer. This literature is subject to all applicable copyright laws and is not for resale in any manner.

PUBLICATION ORDERING INFORMATION

LITERATURE FULFILLMENT:
Literature Distribution Center for ON Semiconductor
P.O. Box 5163, Denver, Colorado 80217 USA
Phone: 303-675-2175 or 800-344-3860 Toll Free USA/Canada
Fax: 303-675-2176 or 800-344-3867 Toll Free USA/Canada
Email: orderlit@onsemi.com

N. American Technical Support: 800-282-9855 Toll Free USA/Canada
Europe, Middle East and Africa Technical Support:
Phone: 421 33 790 2910
Japan Customer Focus Center
Phone: 81-3-5817-1050

ON Semiconductor Website: www.onsemi.com
Order Literature: <http://www.onsemi.com/orderlit>
For additional information, please contact your local Sales Representative