

REV	DESCRIPTION	BY DATE	APPD
A	NPR 1983	00/5/8 LHM	<i>[Signature]</i>

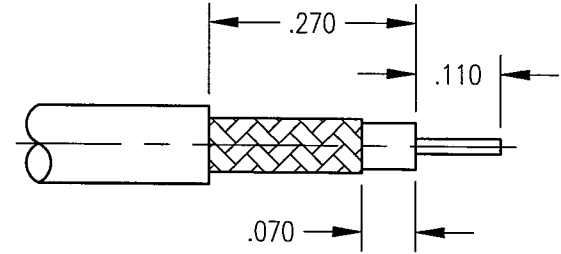
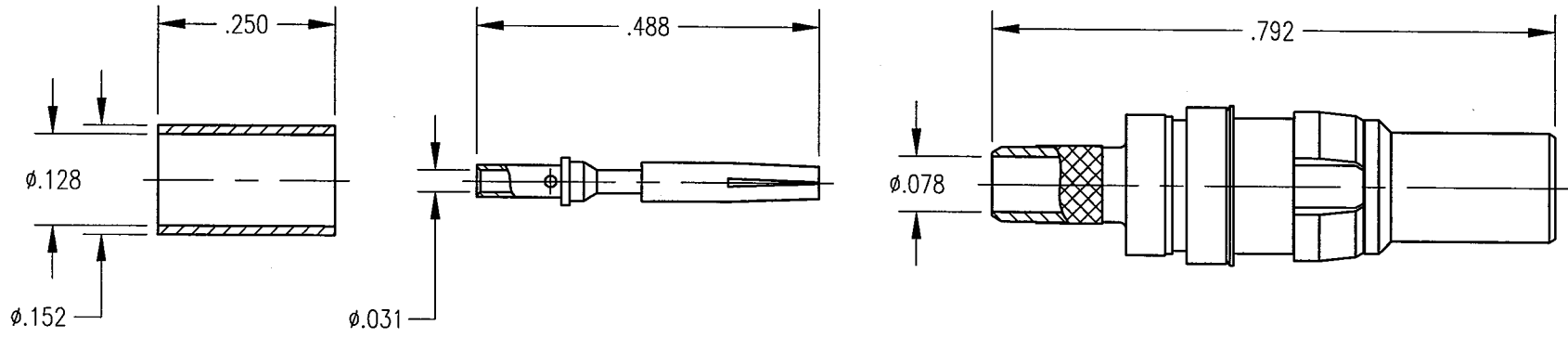

TRIMMING DIMENSION

NOTES:

- MATERIALS:
 CONTACT AND CLIP RING: BERYLLIUM COPPER PER ASTM B196
 SPRING WASHER: PHOSPHOR BRONZE PER ASTM B103
 INSULATOR: TEFLON PER ASTM D1710
 ALL OTHER METAL PARTS: BRASS PER ASTM B16
- FINISH:
 BODIES AND CONTACT: $.000030$ MIN. GOLD PER MIL-G-45204 OVER
 $.000050$ MIN. NICKEL PER QQ-N-290
 FERRULE AND SPRING RING: $.000005$ MIN. GOLD PER MIL-G-45204 OVER
 $.000050$ MIN. NICKEL PER QQ-N-290
 CLIP RING: $.000100$ MIN. NICKEL PER QQ-N-290 OVER
 COPPER FLASH
- DESIGNED FOR USE WITH HARTING 401.01.01 CABLE.
- FOR CABLING PROCEDURES USE CAP 9-07 WITH TRIMMING DIMENSIONS SHOWN.

PER ASME Y14.5M-1994 UNLESS OTHERWISE SPECIFIED: DIMENSIONS ARE IN INCHES (MM)		Litton Winchester/Retconn 400 Park Road Watertown, Connecticut 06795	
TOLERANCES: DECIMALS .XX $\pm .01/0.254$.XXX $\pm .005/0.127$ ANGLES $\pm 2^\circ$		SCALE: 4:1	
CUSTOMER DRAWING		TITLE RDM STRAIGHT PLUG	
DRAWN JWH	DATE 9/5/00	CHECKED <i>[Signature]</i>	DATE 9/6/00
APPROVED <i>[Signature]</i>	DATE 9/6/00	APPROVED <i>[Signature]</i>	DATE 9/6/00
A		260-910-0750G	SH. 1 OF 1 REV. A