

TO-126 Plastic-Encapsulate Transistors

2SD669

2SD669A TRANSISTOR (NPN)

FEATURES

- Low Frequency Power Amplifier Complementary Pair with 2SB649/A

MAXIMUM RATINGS (T_a=25°C unless otherwise noted)

Symbol	Parameter	Value	Unit
V _{CB0}	Collector- Base Voltage	180	V
V _{CEO}	Collector-Emitter Voltage	2SD669	120
		2SD669A	160
V _{EBO}	Emitter-Base Voltage	5	V
I _C	Collector Current -Continuous	1.5	A
P _C	Collector Dissipation	1	W
T _J	Junction Temperature	150	°C
T _{stg}	Storage Temperature	-55-150	°C

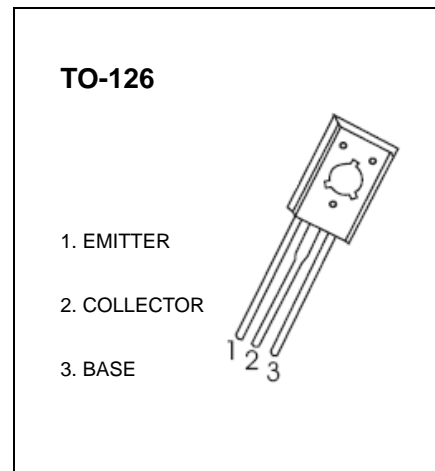

ELECTRICAL CHARACTERISTICS (T_a=25°C unless otherwise specified)

Parameter	Symbol	Test conditions	Min	Typ	Max	Unit
Collector-base breakdown voltage	V _{(BR)CBO}	I _C =1mA, I _E =0	180			V
Collector-emitter breakdown voltage	V _{(BR)CEO}	I _C =10mA, I _B =0	120			V
			2SD669A	160		
Emitter-base breakdown voltage	V _{(BR)EBO}	I _E =1mA, I _C =0	5			V
Collector cut-off current	I _{CBO}	V _{CB} =160V, I _E =0			10	μA
Emitter cut-off current	I _{EBO}	V _{EB} =4V, I _C =0			10	μA
DC current gain	h _{FE(1)}	V _{CE} =5V, I _C =150mA	60		320	
			2SD669A	60		200
	h _{FE(2)}	V _{CE} =5V, I _C =500mA	30			
Collector-emitter saturation voltage	V _{CE(sat)}	I _C =500mA, I _B =50mA			1	V
Base-emitter voltage	V _{BE}	V _{CE} =5V, I _C =150mA			1.5	V
Transition frequency	f _T	V _{CE} =5V, I _C =150mA		140		MHz
Collector output capacitance	C _{ob}	V _{CB} =10V, I _E =0, f=1MHz		14		pF

CLASSIFICATION OF h_{FE(1)}

Rank		B	C	D
Range	2SD669	60-120	100-200	160-320
	2SD669A	60-120	100-200	

Static Characteristic

