

Low Power Ambient Light and Proximity Sensor with Enhanced Infrared Rejection

ISL29038

The ISL29038 is a low power Ambient Light Sensor (ALS) and proximity (PROX) sensor. It has a built-in IR-LED driver for proximity function. The ALS function measures the amount of light (in the visible spectrum) incident on the ISL29038.

The ALS function has a programmable ambient IR-rejection, which allows fine tuning of light source variations and is ideal for light sensor applications under dark protective glass. The ALS provides a 12-bit measurement. A passive optical filter removes unwanted wavelengths (IR or Ultraviolet) to ensure accurate ALS measurement.

The proximity function includes a new offset adjustment to compensate for the IR light reflected off the inside of the protective glass cover and back to the ISL29038 sensor. This offset adjustment allows the sensor to compensate for these internal reflections and preserve the dynamic range of the proximity measurement.

The built-in current-driver pulses an external infrared LED at a programmed current for 90µs. The infrared light that is reflected and received by ISL29038 is digitized by an 8-bit ADC. The proximity sensor also has a passive optical filter designed to pass IR and reject visible wavelengths.

The ISL29038 provides a hardware pin to indicate an interrupt event. The interrupt pin saves power as the host micro-controller can 'wake-up' on an interrupt event and does not need to poll the device for an interrupt event. The interrupt generator is user configurable and provides several options for ALS and PROX trigger configurations. The ISL29038 supports an SMBus compatible I²C interface for configuration and control.

Features

- Ideal for applications under dark or tinted glass
- Enhanced ambient sunlight rejection to 40k Lux
- Programmable proximity sleep time between proximity measurements optimizes power consumption
- Hardware interrupt - no polling required
- Programmable IR compensation to fine tune ALS performance for various glass compositions
- Up to 4000 Lux, four selectable ALS ranges
- Programmable IR LED drive current to 250mA
- Operates from 2.25V to 3.63V V_{DD}
- Power Down I_{DD}, typical 0.2µA_{DC}
- Tiny 2.1x2.0x0.7 (mm) ODFN package

Applications

- Display dimming and adjustment
 - Mobile devices: smart phones, PDA, GPS
 - Computing: monitors, laptops, notebooks
 - Picture frames, tablet-PCs, LCD-TV
- Object detection
 - Touchscreen disabling
 - Smart power-saving

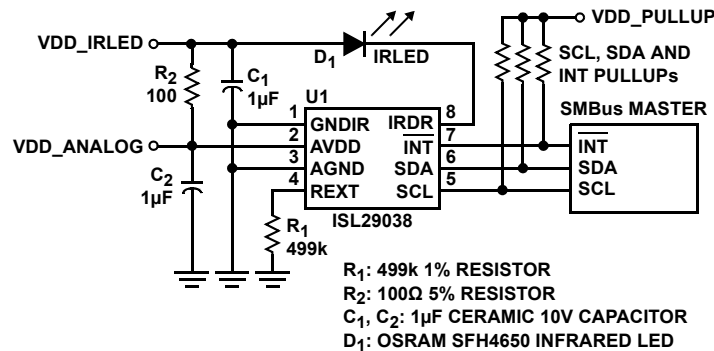

FIGURE 1. TYPICAL APPLICATIONS CIRCUIT

ISL29038

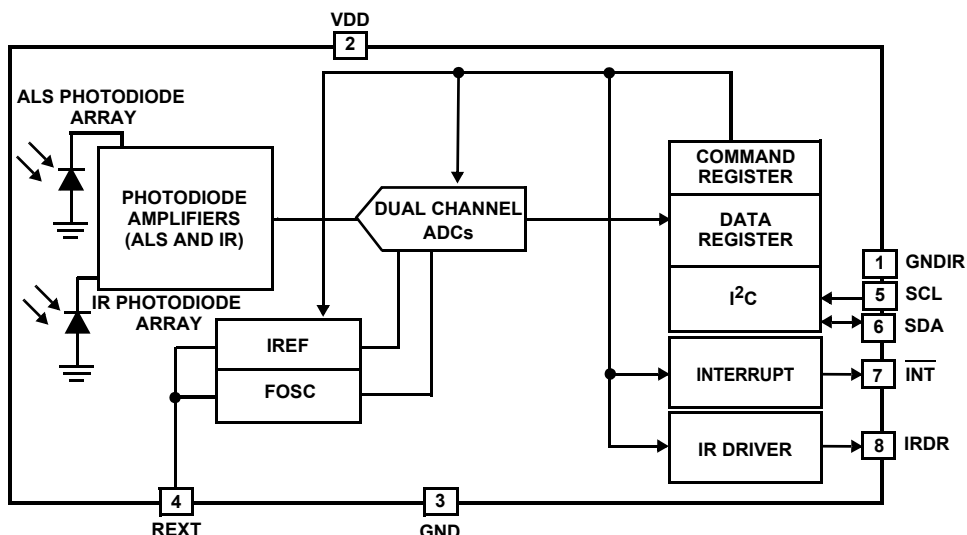
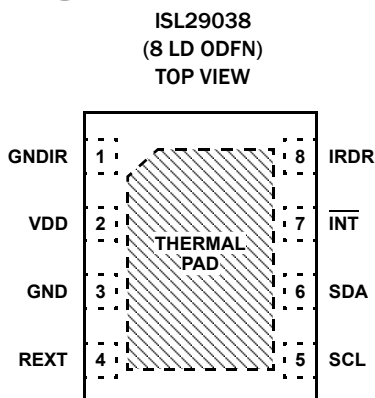

FIGURE 2. ISL29038 BLOCK DIAGRAM

Pin Configuration



Pin Description

PIN#	NAME	DESCRIPTION
1	GNDIR	Ground for IRDR LED Current.
2	VDD	Positive supply: 2.25V to 3.63V.
3	GND	Ground.
4	REXT	External Resistor, Connect to GND pin through a 499k Ω , 1% resistor.
5	SCL	I ² C Serial Clock Input.
6	SDA	I ² C Serial Data Input/Output.
7	$\overline{\text{INT}}$	Active Low, Open-Drain Output.
8	IRDR	IR-LED Driver Sink - Connect to IR LED Cathode.
-	TPAD	Thermal Pad - Connect to GND.

For additional products, see www.intersil.com/en/products.html

Intersil products are manufactured, assembled and tested utilizing ISO9000 quality systems as noted in the quality certifications found at www.intersil.com/en/support/qualandreliability.html

Intersil products are sold by description only. Intersil Corporation reserves the right to make changes in circuit design, software and/or specifications at any time without notice. Accordingly, the reader is cautioned to verify that data sheets are current before placing orders. Information furnished by Intersil is believed to be accurate and reliable. However, no responsibility is assumed by Intersil or its subsidiaries for its use; nor for any infringements of patents or other rights of third parties which may result from its use. No license is granted by implication or otherwise under any patent or patent rights of Intersil or its subsidiaries.

For information regarding Intersil Corporation and its products, see www.intersil.com