



URXX20

LINEAR INTEGRATED CIRCUIT

2A OUTPUT TYPE LOW POWER-LOSS VOLTAGE REGULATOR

■ FEATURES

- * Low power-loss(Dropout voltage: 0.5V(max) at I_{OUT}=2.0A)
- * 2.0A output type
- * Output voltage precision: ±3.0%
- * Built-in ON/OFF control function and over-current protection circuit.
- * Thermal shutdown protection.

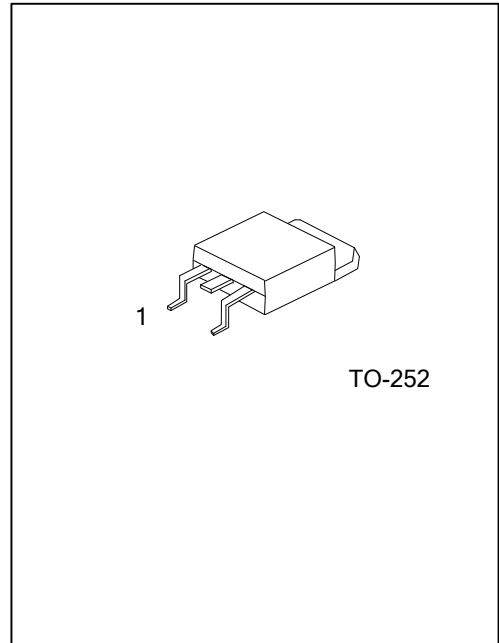

■ ORDERING INFORMATION

Ordering Number		Package	Pin Assignment			Packing
Lead Free	Halogen Free		1	2	3	
URXX20L-TN3-D-T	URXX20G-TN3-D-T	TO-252	I	G	O	Tube
URXX20L-TN3-D-R	URXX20G-TN3-D-R	TO-252	I	G	O	Tape Reel

Note: Pin Assignment: I: INPUT G: GND O: OUTPUT

<p>URXX20L-TN3-D-T</p> <p>(1) Packing Type (2) Pin Assignment (3) Package Type (4) Lead Free (5) Voltage Code</p>	<p>(1) T: Tube, R: Tape Reel (2) refer to Assignment (3) TN3: TO-252 (4) L: Lead Free, G: Halogen Free (5) XX: refer to Marking Information</p>
---	---

MARKING INFORMATION

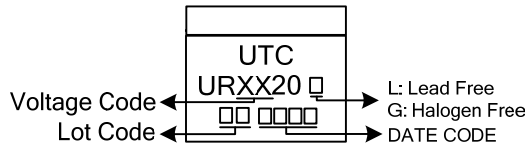
PACKAGE	VOLTAGE CODE	MARKING
TO-252	12 :12V	 <p>Voltage Code ← URXX20 → L: Lead Free G: Halogen Free DATE CODE ← Lot Code →</p>

BLOCK DIAGRAM

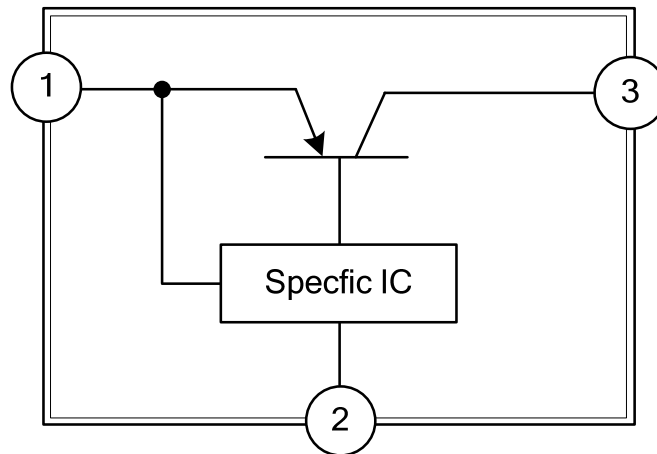

ABSOLUTE MAXIMUM RATINGS ($T_A=25^{\circ}\text{C}$, unless otherwise specified.)

PARAMETER	SYMBOL	RATINGS	UNIT
Input Voltage(Note1)	V_{IN}	20	V
Output Current	I_{OUT}	2.0	A
Power Dissipation	P_D	0.7	W
Junction Temperature (Note2)	T_J	150	$^{\circ}\text{C}$
Operating Temperature	T_{OPR}	-40 ~ +85	$^{\circ}\text{C}$
Storage Temperature	T_{STG}	-40 ~ +150	$^{\circ}\text{C}$

Note 1: All are open except GND and applicable terminals.

2: Overheat protection may operate at $125 \leq T_J \leq 150^{\circ}\text{C}$

■ ELECTRICAL CHARACTERISTICS (Refer to the test circuits, unless otherwise specified, $T_A=25^{\circ}\text{C}$)

For UR1220(12V)

PARAMETER	SYMBOL	TEST CONDITIONS	MIN	TYP	MAX	UNIT
Output Voltage	V_{OUT}	$V_{IN}=14\text{V}$, $I_{OUT}=1\text{A}$	11.64	12.0	12.36	V
Line Regulation	ΔV_{OUT}	$V_{IN}=13\sim 19\text{V}$, $I_{OUT}=5\text{mA}$		0.5	2.5	%
Load Regulation	ΔV_{OUT}	$V_{IN}=14\text{V}$, $I_{OUT}=5\text{mA}\sim 2.0\text{A}$		0.1	2.0	%
Temperature Coefficient of Output Voltage	$T_C V_O$	$T_J=0\sim 125^{\circ}\text{C}$, $I_{OUT}=5\text{mA}$		± 0.02		$\%/^{\circ}\text{C}$
Ripple Rejection	RR	Refer to Fig.2	45	55		dB
Dropout Voltage	V_D	(Note 1), $I_{OUT}=2\text{A}$			0.5	V
Quiescent Current	I_Q	$I_{OUT}=0\text{A}$, $V_{IN}=14\text{V}$			10	mA

Note: Input voltage shall be the value when output voltage is 95% in comparison with the initial value.

■ TEST CIRCUITS

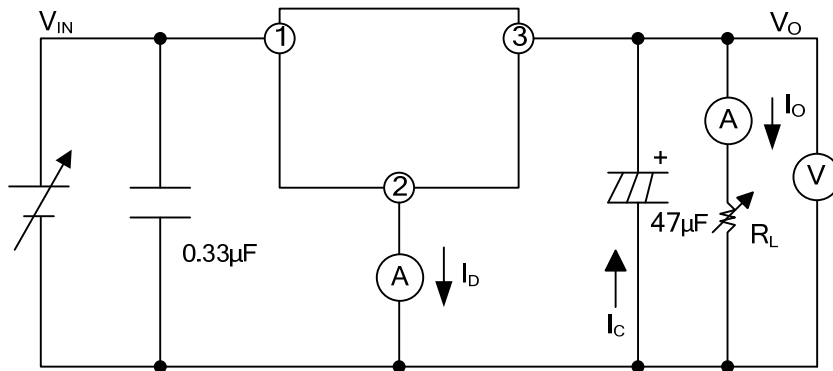
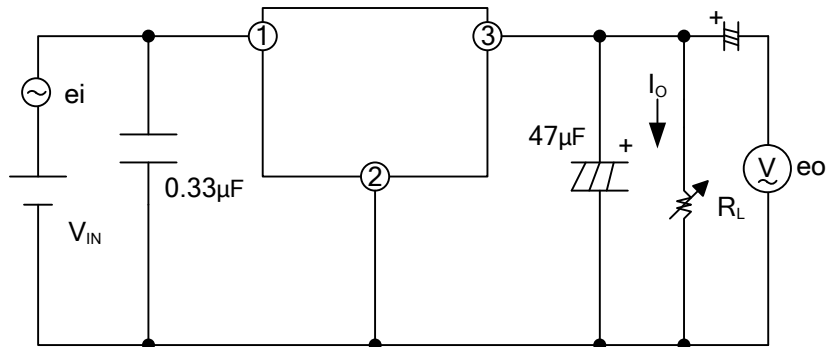

Fig.1



$V_{IN}=12V(UR1020)$ $f=120Hz$
 $e_i=0.5V_{rms}$
 $I_o=0.5A$
 $RR=20\log(e_i/e_o)$

Fig.2 For Ripple Rejection

■ TYPICAL APPLICATION

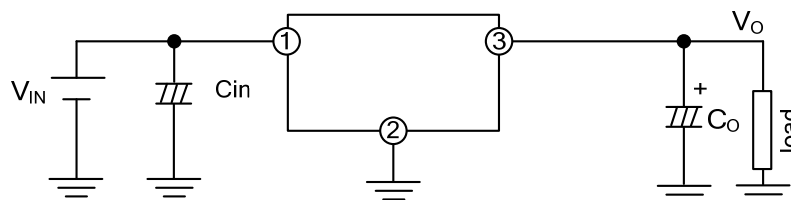

TYPICAL CHARACTERISTICS

Fig.3 Output Voltage Deviation vs .Junction Temperature (UR1220)

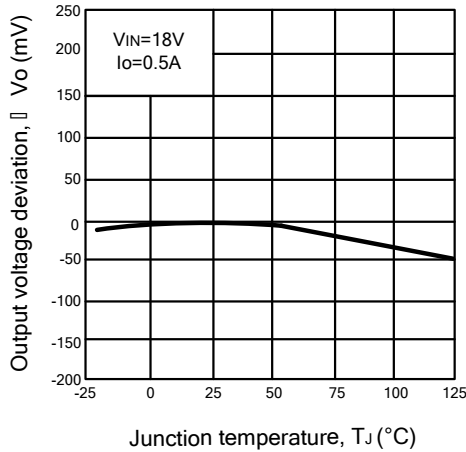

Fig.4 Output Voltage vs .Input Voltage (UR1220)

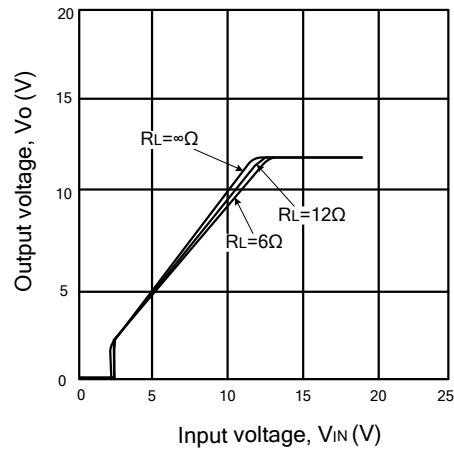

Fig.5 Circuit Operating Current vs .Input Voltage (UR1220)

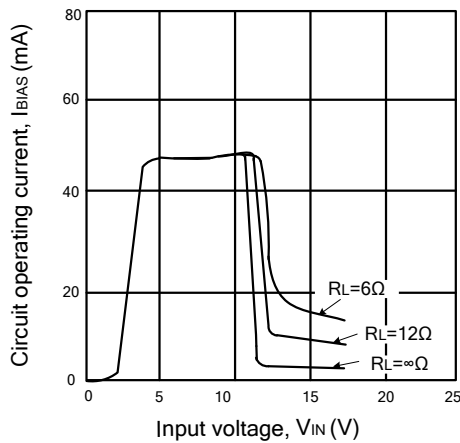

Fig.6 Dropout Voltage vs .Junction Temperature (UR1220)

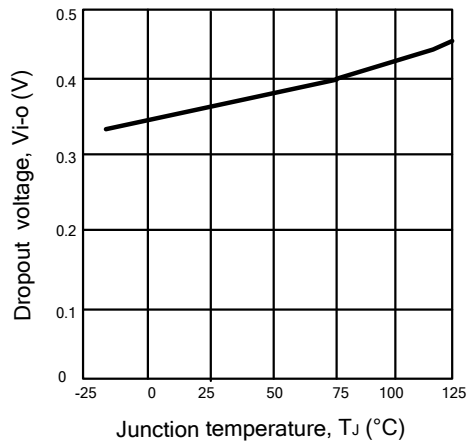

Fig.7 Quiescent Current vs .Junction Temperature (UR1220)

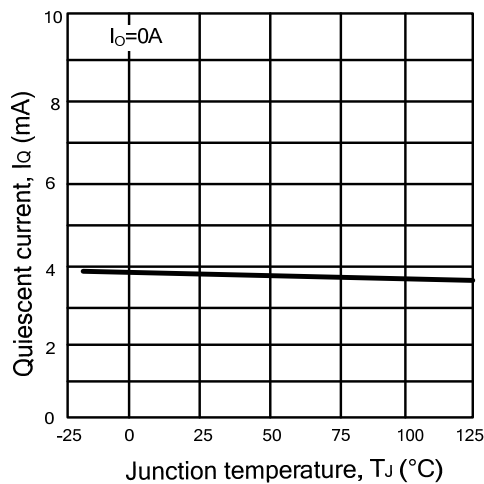
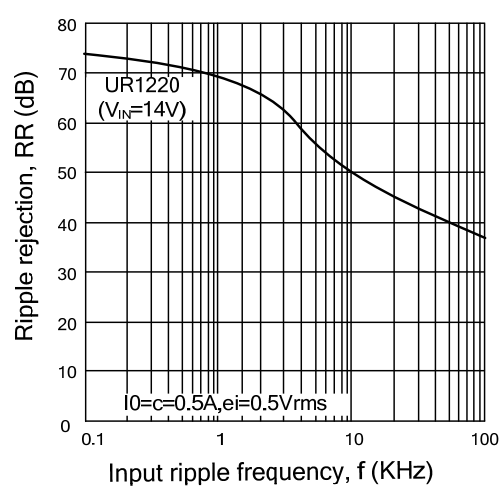
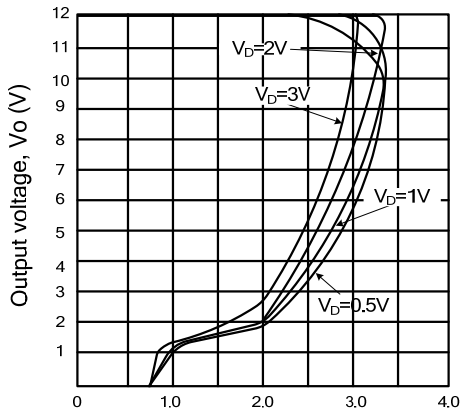

Fig.8 Ripple Rejection vs .Input Ripple Frequency



■ TYPICAL CHARACTERISTICS(Cont.)

Fig.9 Overcurrent Protection Characteristics
(Typical Value) (UR1220)



UTC assumes no responsibility for equipment failures that result from using products at values that exceed, even momentarily, rated values (such as maximum ratings, operating condition ranges, or other parameters) listed in products specifications of any and all UTC products described or contained herein. UTC products are not designed for use in life support appliances, devices or systems where malfunction of these products can be reasonably expected to result in personal injury. Reproduction in whole or in part is prohibited without the prior written consent of the copyright owner. The information presented in this document does not form part of any quotation or contract, is believed to be accurate and reliable and may be changed without notice.