

SCHNITT A-A

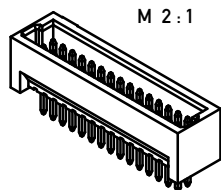

M 2:1

Layout
M 2:1

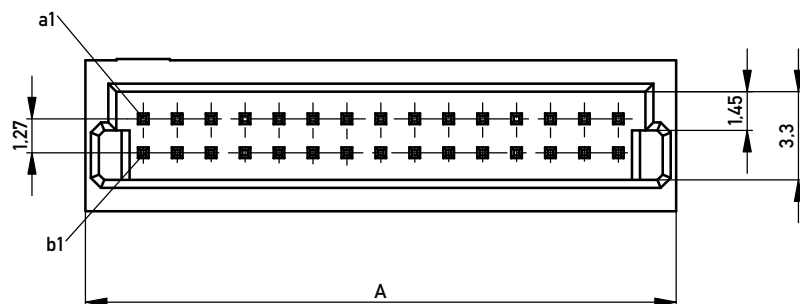
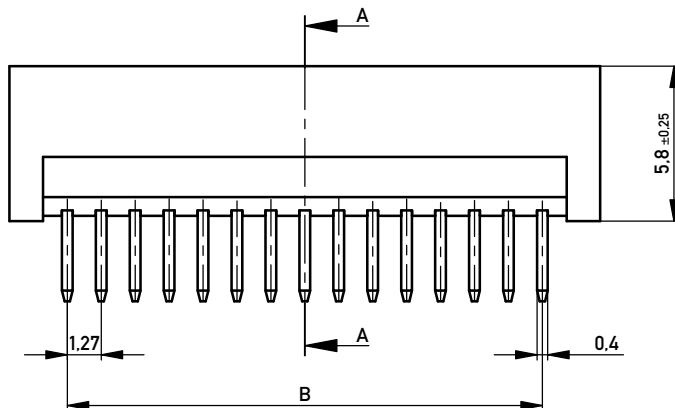
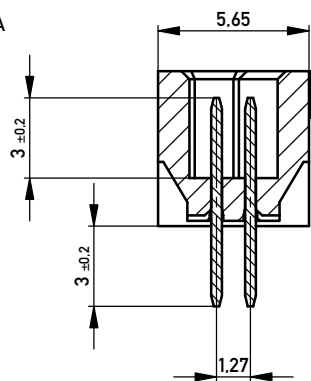
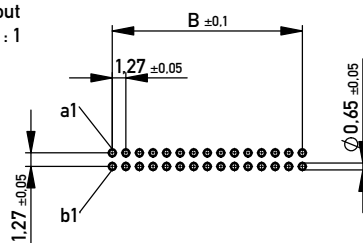

Verpackung Stange / Stange & Ansaughaube
packaging tube / tube&cap

100	9
80	11
70	12
60	14
50	17
40	21
30	27
20	38
10	64
Polzahl No. of positions	Stück / pieces

Masse und Toleranzen in Übereinstimmung mit ANSI Y15.5M-1994 /
Interpret dimensions according to ANSI Y15.5M-1994

109256	109247	109238	109229	100	66.56	62.23
109255	109246	109237	109228	80	53.86	49.53
109254	109245	109236	109227	70	47.51	43.18
109253	109244	109235	109226	60	41.16	36.83
109252	109243	109234	109225	50	34.81	30.48
109251	109242	109233	109224	40	28.46	24.13
109250	109241	109232	109223	30	22.11	17.78
109249	109240	109231	109222	20	15.76	11.43
109248	109239	109230	109221	10	9.41	5.08
Id-Nr. tube&cap 100 mating- cycles	Id-Nr. tube&cap 10 mating- cycles	Id-Nr. tube 100 mating- cycles	Id-Nr. tube 10 mating- cycles	Polzahl no of positions	Mass A	Mass B

Copyright by ERNI GmbH
Proprietary notice pursuant to ISO 9006 to be observed.

Information:	Tolerances	All Dimensions in mm	Scale 5:1
All rights reserved. Only for Information. To ensure that this is the latest version of this drawing, please contact one of the ERNI companies before using.	Subject to modification without prior notice. Drawing will not be updated.	Designation	
		MiniMez Vertical Male DIP without pegs 1,9mm	
www.ERNI.com		109220	
		Class MINIMEZ	
Index	Date		