

APPROVED: _____
 DATE: _____ TITLE: _____

Rev	AWO #	Description	Date	Appr
-		RELEASED	11/02/07	
A		UPDATED	6/10/08	

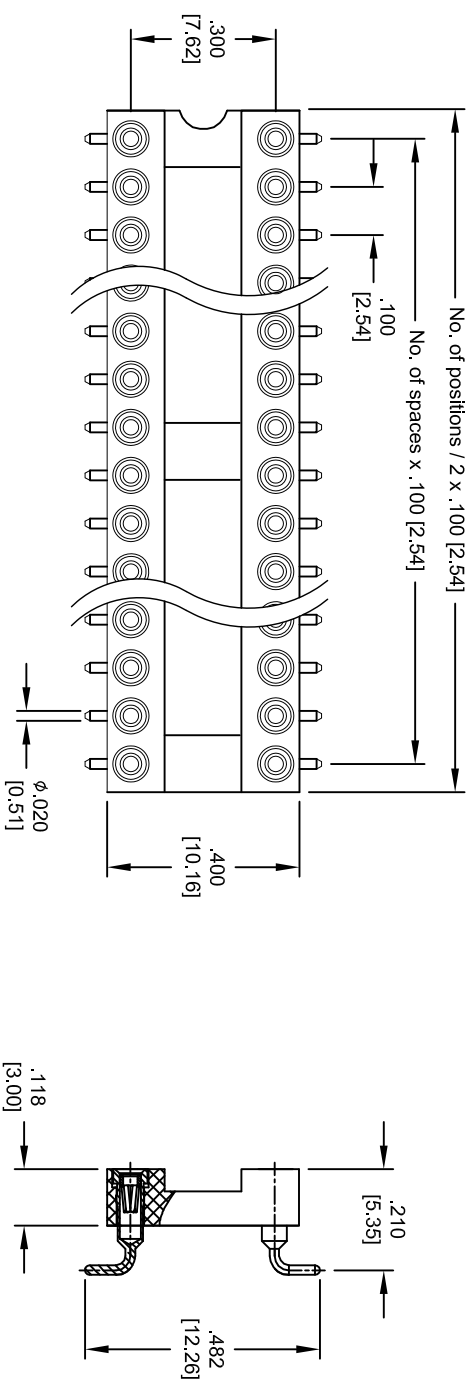

SPECIFICATIONS:
 Material: Insulator: PBT, Glass reinforced, rated UL 94V-0
 Insulator color: Black
 Contacts: Beryllium Copper
 Outer Pin: Brass, Nickel plated
 Plating: Gold flash over Nickel underplate on inner contact, Tin over Copper underplate on outer sleeve

Positions: 06 thru 52

Electrical:
 Operating voltage: 60 VAC max
 Current rating: 3 Amp max
 Contact resistance: 40 mohms max
 Insulation resistance: 1000 Mohms min @ 500 VDC
 Dielectric withstanding voltage: 500 VAC for 1 minute
 Temperature Rating: Operating temperature: -55°C to +125°C

Environmental:
 Lead free, RoHS compliant.
 Recommended soldering temp: 235°C for 5 sec.



UNLESS OTHERWISE SPECIFIED ALL DIMENSIONS ARE INCHES [MM] TOLERANCES: EXCEPT AS NOTED INCHES		HOLE SIZE	
.X	± .10	ØXX	± .10
.XX	± .020	ØXXX	± .015
.XXX	± .015	ØXXXX	± .010
APPROVALS		DATE	
DRAWN	SS	11/02/07	
CHECKED	LW	7/30/10	
APPROVED			

ADAM TECH
 909 Rahway Avenue, Union, NJ 07083
 Phone: 908-687-5000 Fax: 908-687-5710

TITLE: **SCREW MACHINE IC SOCKET**
 .300" ROW, SPACING, SMT

SIZE	PART NO.	REV.
X	ICM-3XX-SMT-GT	A
REF:	SCALE: NTS	SHEET 1 OF 1