

ILC7362

CMOS Negative LDO Regulator

Features

- Ultra-Low Supply Current (3 μ A typ.)
- All-CMOS Design in SOT-23 and SOT-89 Packages
- $\pm 2\%$ Precision Output Voltage
- Output Current Limit
- Package and Voltage Options allow:
 - 100mA/-6V Regulator
 - 100mA/-5V Regulator
 - 60mA/-3V Regulator

General Description

The ILC7362 is a low quiescent current, negative voltage LDO. It provides up to 60 or 100mA output current with low power consumption and small input-output differential voltage.

The ILC7362 is available in SOT23-3 (max.150mW) or SOT89-3 (max.500mW) package, for a number of fixed voltage and current offerings.

Applications

- Battery-Operated Systems
- Portable Computers and Cameras
- Cellular/GSM/PHS Phones
- PDAs

Block Diagram

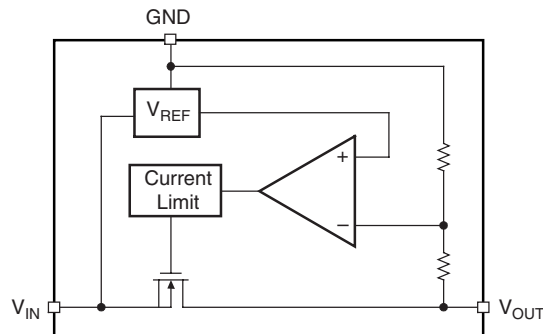

Pin Configurations

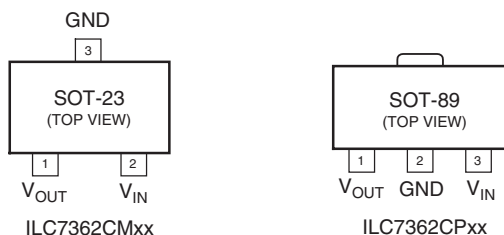

Pin Definitions

Pin Number		Pin Name	Pin Function Description
SOT-23	SOT-89		
1	1	V _{OUT}	Regulated Voltage Output
2	3	V _{IN}	Power Supply Input
3	2	GND	Ground Connection

Absolute Maximum Ratings

Absolute maximum ratings are the values beyond which the device may be damaged or have its useful life impaired. Functional operation under these conditions is not implied.

Parameter		Min.	Max.	Units
Supply Voltage: V _{IN} to GND			-12	V
Output Current: I _{OUT}			200	mA
Output Voltage: V _{OUT} to GND		0.3	V _{IN} - 0.3	V
Junction Temperature (T _J)		-40	125	°C
Storage Temperature		-40	125	°C
Lead Soldering Temperature, 10 seconds			300	°C
Continuous Total Power Dissipation (P _D) at T _A =25°C	SOT-23		150	mW
	SOT-89		500	

Recommended Operating Conditions

Parameter	Conditions	Min.	Typ.	Max.	Units
Supply Voltage Range V _{IN}		V _{OUT} - V _{DO}	V _{OUT} - 1	-10	V
Ambient Operating Temperature		-30	25	80	°C

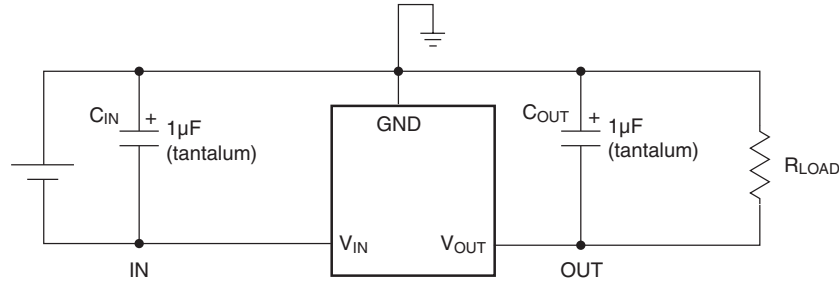

Figure 1. Test Circuit

Electrical Specifications ILC7362Cx-60

($V_{IN} = V_{OUT} - 1V$, and $T_A = 25^\circ C$ using circuit in Figure 1, unless otherwise noted.)

Parameter	Symbol	Conditions	Min.	Typ.	Max.	Units
Output Voltage	V_{OUT}	$I_{OUT} = 20mA$	0.98 V_{OUTnom}	$V_{OUTnom} = -6.0$	1.02 V_{OUTnom}	V
Maximum Output Current, Note 1	$I_{OUTMAX.}$	$-V_{OUT} \geq -0.9V_{OUTnom}$	100			mA
Load Regulation	ΔV_{OUT}	$1mA \leq I_{OUT} \leq 50mA$		40	80	mV
Dropout Voltage, Note 2	V_{DO}	$I_{OUT} = 50mA$		120	300	mV
		$I_{OUT} = 100mA$		380	600	
Ground Current	I_{GND}			3.0	7.0	μA
Line Regulation	$\frac{\Delta V_{OUT}}{\Delta V_{IN} \times V_{OUT}}$	$I_{OUT} = 20mA$ $7V \leq -V_{IN} \leq 10V$		0.1	0.3	%/V
Output Voltage Temperature Coefficient	$\frac{\Delta V_{OUT}}{\Delta T \times V_{OUT}}$	$I_{OUT} = 30mA$ $-30^\circ C \leq T \leq 80^\circ C$		± 100		ppm/ $^\circ C$

Electrical Specifications ILC7362Cx-50

($V_{IN} = V_{OUT} - 1V$, and $T_A = 25^\circ C$ using circuit in Figure 1, unless otherwise noted.)

Parameter	Symbol	Conditions	Min.	Typ.	Max.	Units
Output Voltage	V_{OUT}	$I_{OUT} = 20mA$	0.98 V_{OUTnom}	$V_{OUTnom} = -5.0$	1.02 V_{OUTnom}	V
Maximum Output Current, Note 1	$I_{OUTMAX.}$	$-V_{OUT} \geq -0.9V_{OUTnom}$	100			mA
Load Regulation	ΔV_{OUT}	$1mA \leq I_{OUT} \leq 50mA$		40	80	mV
Dropout Voltage, Note 2	V_{DO}	$I_{OUT} = 50mA$		120	300	mV
		$I_{OUT} = 100mA$		380	600	
Ground Current	I_{GND}			3.0	7.0	μA
Line Regulation	$\frac{\Delta V_{OUT}}{\Delta V_{IN} \times V_{OUT}}$	$I_{OUT} = 20mA$ $7V \leq -V_{IN} \leq 10V$		0.1	0.3	%/V
Output Voltage Temperature Coefficient	$\frac{\Delta V_{OUT}}{\Delta T \times V_{OUT}}$	$I_{OUT} = 30mA$ $-30^\circ C \leq T \leq 80^\circ C$		± 100		ppm/ $^\circ C$

Electrical Specifications ILC7362Cx-30

($V_{IN} = V_{OUT} + 1V$, and $T_A = 25^\circ C$ using circuit in Figure 1, unless otherwise noted.)

Parameter	Symbol	Conditions	Min.	Typ.	Max.	Units
Output Voltage	V_{OUT}	$I_{OUT} = 20mA$	0.98 V_{OUTnom}	$V_{OUTnom} = -3.0$	1.02 V_{OUTnom}	V
Maximum Output Current, Note 1	$I_{OUTMAX.}$	$-V_{OUT} \geq -0.9V_{OUTnom}$	60			mA
Load Regulation	ΔV_{OUT}	$1mA \leq I_{OUT} \leq 50mA$		40	80	mV
Dropout Voltage, Note 2	V_{DO}	$I_{OUT} = 40mA$		120	300	mV
		$I_{OUT} = 80mA$		380	600	
Ground Current	I_{GND}			2.5	6.0	μA
Line Regulation	$\frac{\Delta V_{OUT}}{\Delta V_{IN} \times V_{OUT}}$	$I_{OUT} = 20mA$ $4V \leq -V_{IN} \leq 10V$		0.1	0.3	%/V
Output Voltage Temperature Coefficient	$\frac{\Delta V_{OUT}}{\Delta T \times V_{OUT}}$	$I_{OUT} = 30mA$ $-30^\circ C \leq T \leq 80^\circ C$		± 100		ppm/ $^\circ C$

Notes:

- I_{OUTMAX} is limited also by the maximum allowable power dissipation for the package.
- V_{DO} is the input to output differential voltage at which the output voltage drop 2% below V_{OUT} .

Typical Characteristics

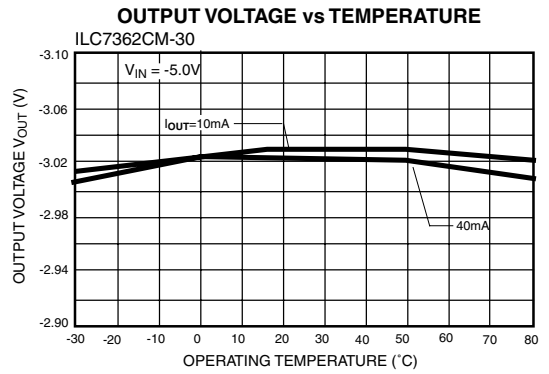
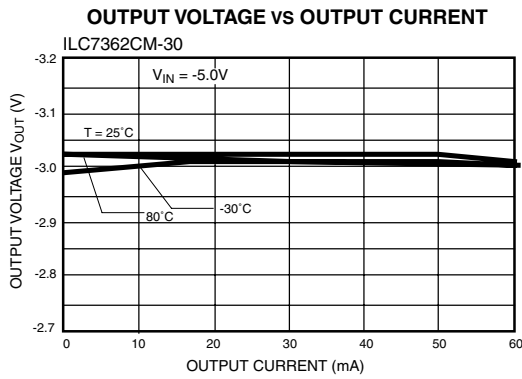
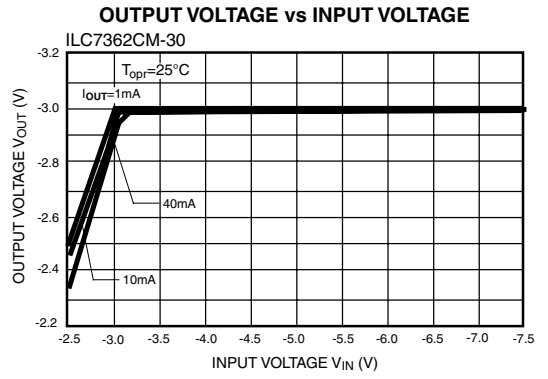
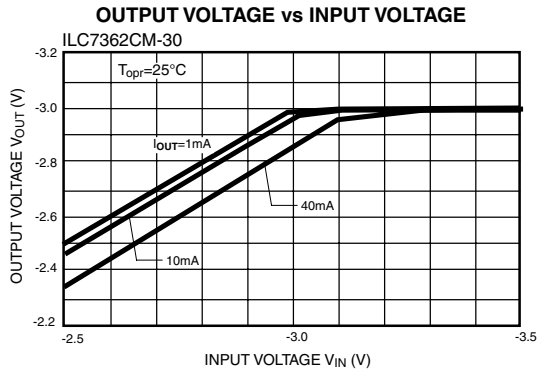

Mechanical Dimensions

SOT-23-3

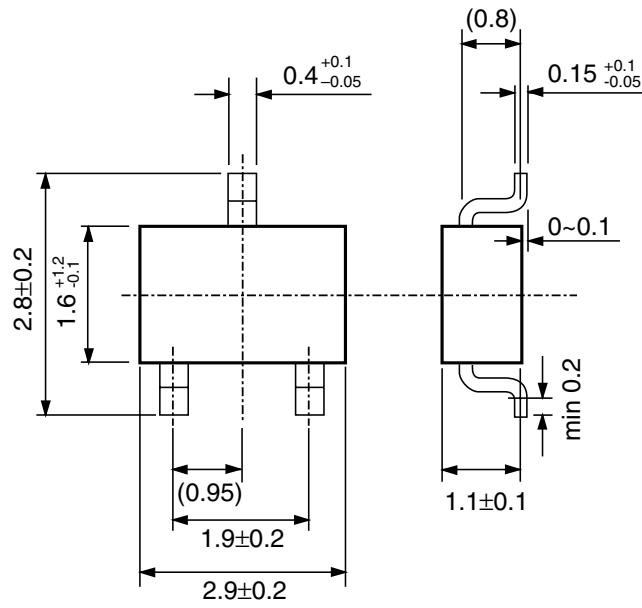

SOT-89-3

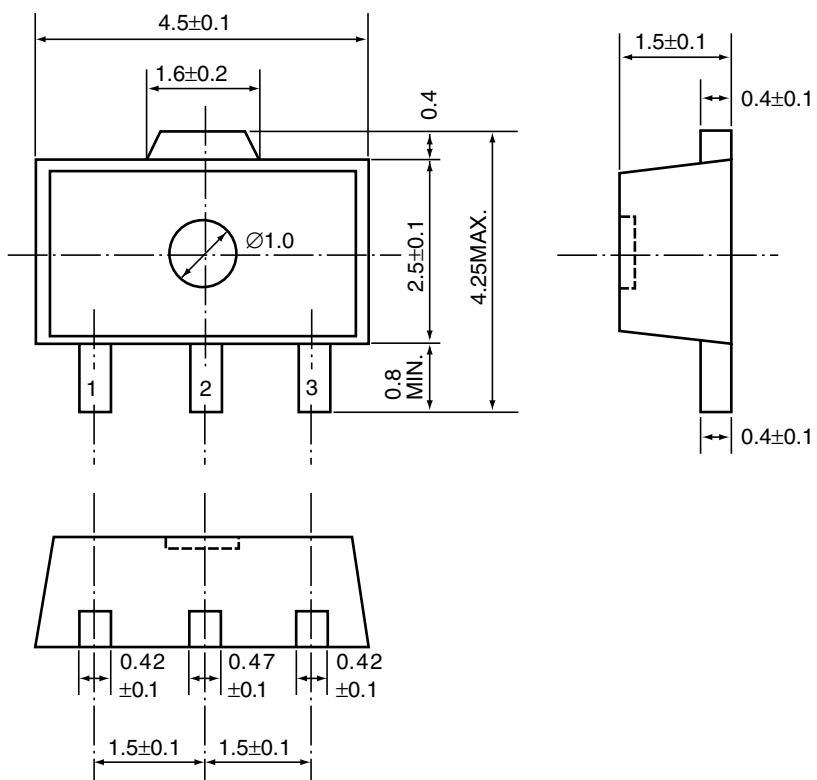

Ordering Information

Part Number	V _{OUT} (V)	Temperature Range (°C)	Package
ILC7362CP50X	-5	-30 to +80 °C	SOT89
ILC7362CP30X	-3	-30 to +80 °C	SOT89
ILC7362CM60X	-6	-30 to +80 °C	SOT23
ILC7362CM50X	-5	-30 to +80 °C	SOT23
ILC7362CM30X	-3	-30 to +80 °C	SOT23

DISCLAIMER

FAIRCHILD SEMICONDUCTOR RESERVES THE RIGHT TO MAKE CHANGES WITHOUT FURTHER NOTICE TO ANY PRODUCTS HEREIN TO IMPROVE RELIABILITY, FUNCTION OR DESIGN. FAIRCHILD DOES NOT ASSUME ANY LIABILITY ARISING OUT OF THE APPLICATION OR USE OF ANY PRODUCT OR CIRCUIT DESCRIBED HEREIN; NEITHER DOES IT CONVEY ANY LICENSE UNDER ITS PATENT RIGHTS, NOR THE RIGHTS OF OTHERS.

LIFE SUPPORT POLICY

FAIRCHILD'S PRODUCTS ARE NOT AUTHORIZED FOR USE AS CRITICAL COMPONENTS IN LIFE SUPPORT DEVICES OR SYSTEMS WITHOUT THE EXPRESS WRITTEN APPROVAL OF THE PRESIDENT OF FAIRCHILD SEMICONDUCTOR CORPORATION. As used herein:

1. Life support devices or systems are devices or systems which, (a) are intended for surgical implant into the body, or (b) support or sustain life, and (c) whose failure to perform when properly used in accordance with instructions for use provided in the labeling, can be reasonably expected to result in a significant injury of the user.
2. A critical component in any component of a life support device or system whose failure to perform can be reasonably expected to cause the failure of the life support device or system, or to affect its safety or effectiveness.