

Applications

- WLAN
- Cellular Infrastructure
- Test and Measurement
- Smart Energy
- UHF/VHF
- LMR
- General Purpose Broadband Wireless

Product Features

- General Purpose
- Broadband: 100–6000 MHz
- Low Insertion Loss: 0.3 dB at 1 GHz
- High Input IP3: +56 dBm at 1 GHz
- CMOS Compatible Dual Voltage Control
- Lead Free, RoHS Compliant SMT Package

General Description

The TQP4M0008 is a GaAs FET single-pole, double throw (SPDT) low loss reflective switch with good isolation. The TQP4M0008 may be operated DC control signals from 1.8 to 5 Volts. The TQP4M0008 has 100–6000 MHz broadband performance.

The TQP4M0008 is packaged in a RoHS-compliant, compact 6-pin 2x2 mm surface-mount leadless package.

The TQP4M0008 is an ideal choice for wireless infrastructure and test & measurement applications requiring low insertion loss and high input IP3. It can also be used for any general purpose RF application.



6-pin 2x2 mm SLP Package

Functional Block Diagram

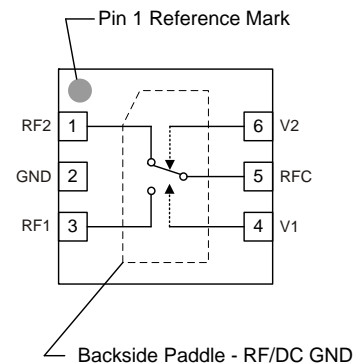

Pin Configuration

Pin No.	Symbol
1	RF2
2	GND
3	RF1
4	V1
5	RFC
6	V2
Backside Paddle	RF/DC GND

Ordering Information

Part No.	Description
TQP4M0008	SPDT Reflective Switch
TQP4M0008-PCB	0.1-6 GHz Evaluation Board

Standard T/R size = 2500 pieces on a 7" reel

Absolute Maximum Ratings

Parameter	Rating
Storage Temperature	-65 to 150°C
RF Input Power, CW, 50Ω, T = 25°C	+33 dBm
Max RF Input Power, (peak envelope)	+37 dBm
Control Voltage (V1, V2)	+6 V

Operation of this device outside the parameter ranges given above may cause permanent damage.

Recommended Operating Conditions

Parameter	Min	Typ	Max	Units
V1, V2 High State	+1.8	+3.3	+5.0	V
Operating Temp. Range	-40		+85	°C

Electrical specifications are measured at specified test conditions. Specifications are not guaranteed over all recommended operating conditions.

Electrical Specifications

Test conditions unless otherwise noted: V1=+3 V, V2=0 V, Temp=25°C, 50 Ω system

Parameter	Conditions	Min	Typ	Max	Units
Operational Frequency Range		100		6000	MHz
Control Voltage (V1, V2) ⁽¹⁾	Low	0		0.45	V
	High	+1.8	+3.3	+5	V
Insertion Loss	0.1 – 1.0 GHz		0.35		dB
	1.0 – 2.5 GHz		0.45		
	2.5 – 3.0 GHz		0.55		
	3.0 – 4.5 GHz		0.65		
	4.5 – 6.0 GHz		0.85		
Isolation	0.1 – 1.0 GHz		30		dB
	1.0 – 2.5 GHz		25		
	2.5 – 3.0 GHz		22		
	3.0 – 4.5 GHz		20		
	4.5 – 6.0 GHz		17		
RFC Return Loss	0.1 – 1.0 GHz		20		dB
	1.0 – 2.5 GHz		15		
	2.5 – 3.0 GHz		15		
	3.0 – 4.5 GHz		17		
	4.5 – 6.0 GHz		15		
Input P1dB ⁽¹⁾	f=1 GHz		+37		dBm
Input IP3 ⁽¹⁾	f=1 GHz, Δf=1 MHz Pout=+15 dBm/tone		+56		dBm
Switching Speed	t _{OFF,tON} (50% CTL to 10/90% RF)		110		ns
	t _{OFF,tON} (50% CTL to 2/98% RF)		180		ns
Control Voltage Bias Current	V1 or V2=5 V			15	uA

Notes:

1. Specified IP3 and P1dB are for V1 or V2 ≥ +3.3 V.

Digital Control Voltages

State	Bias Condition
Low	≤ +0.45 V
High	≥ +1.8V

Switch Control Truth Table

Control Voltages		Signal Path State	
V1	V2	RFC to RF1	RFC to RF2
Low	High	Off (isolation)	On (Insertion Loss)
High	Low	On (Insertion Loss)	Off (isolation)

TQP4M0008-PCB Evaluation Board

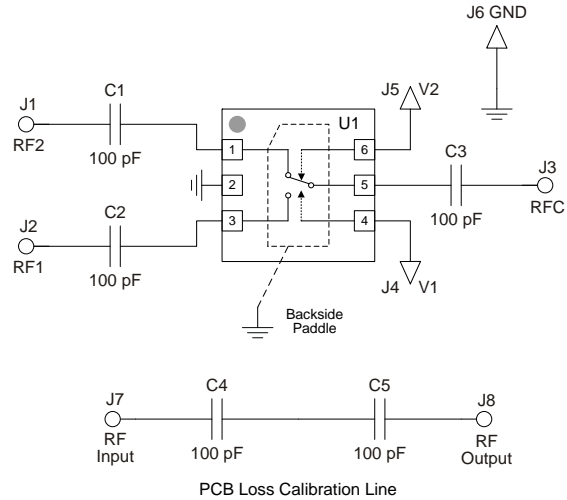
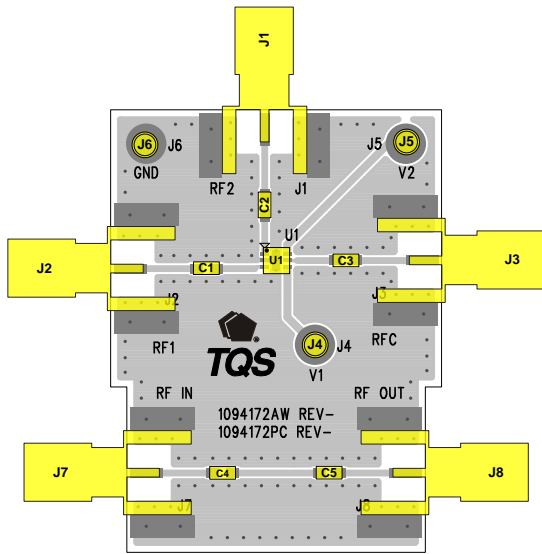

TriQuint PCB 1094172 Material and Stack-up

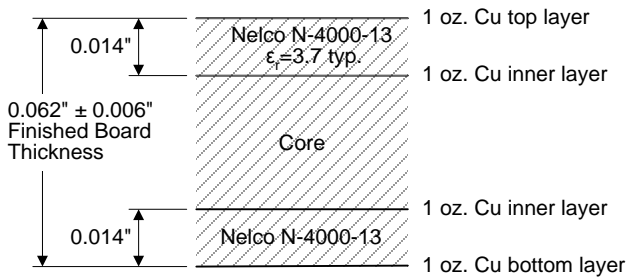

50 ohm line dimensions: Width = .021"
Spacing = .006"

Notes:

- J7 to J8 thru line may be used to de-embed PCB losses to device.

Typical Performance – TQP4M0008-PCB

Test conditions unless otherwise noted: V1=+3 V, V2=0 V, Temp=25°C, 50 Ω system

Parameter	Typical Value			Units
Frequency	1	2	3	GHz
Insertion Loss ⁽¹⁾	0.3	0.4	0.45	dB
RFC Port Return Loss	19	15	14	dB
RFC to RF1/RF2 Isolation	32	26	24	dB
RF1 to RF2 Isolation	33	26	25	dB
Input P1dB	+36	+35.5	+35	dBm
Input IP3 (f=1 GHz, 1 MHz tone spacing, Pout=+15 dBm/tone)	+54	+57	+59	dBm

Notes:

- Insertion Loss values reflect de-embedding of evaluation board RF line losses.

Performance Plots – TQP4M0008-PCB

Test conditions unless otherwise noted: V1=+3 V, V2=0 V, Temp.=+25°C, 50 Ω system

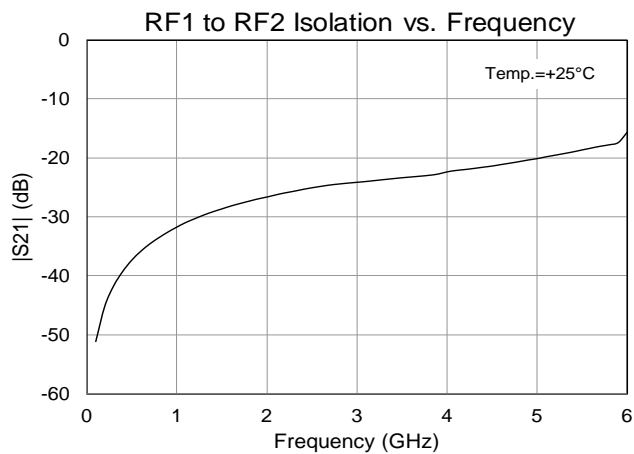
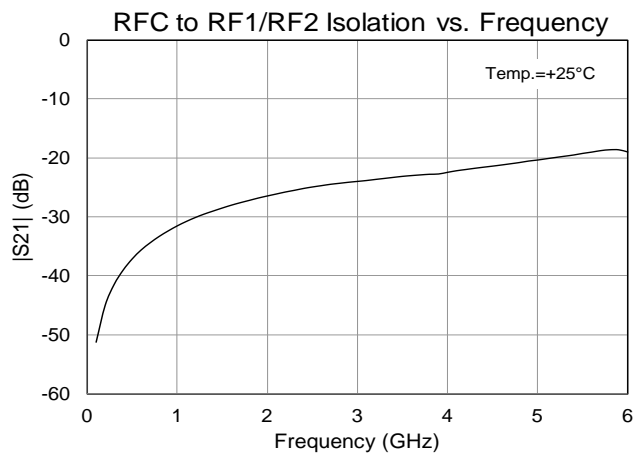
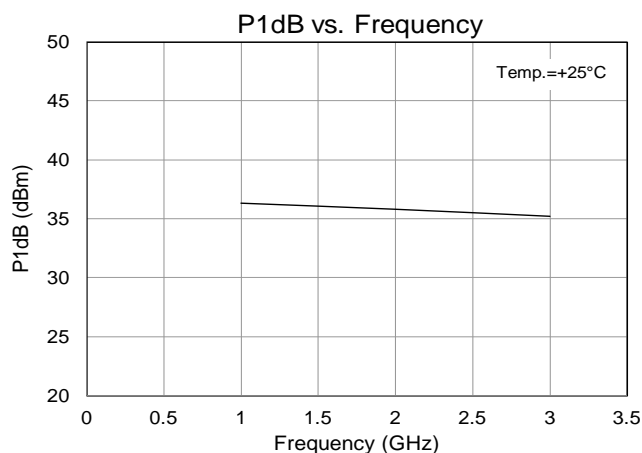
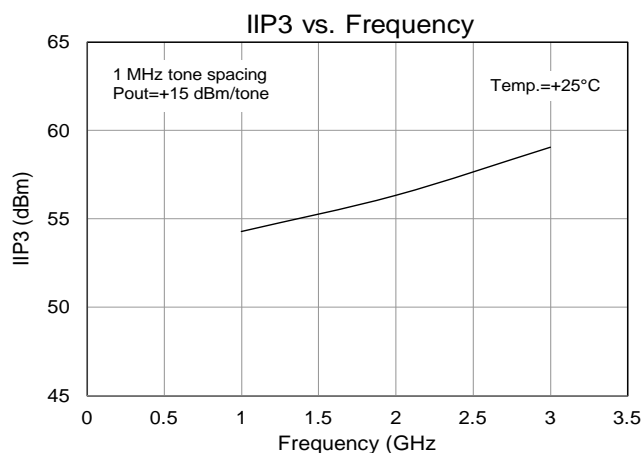
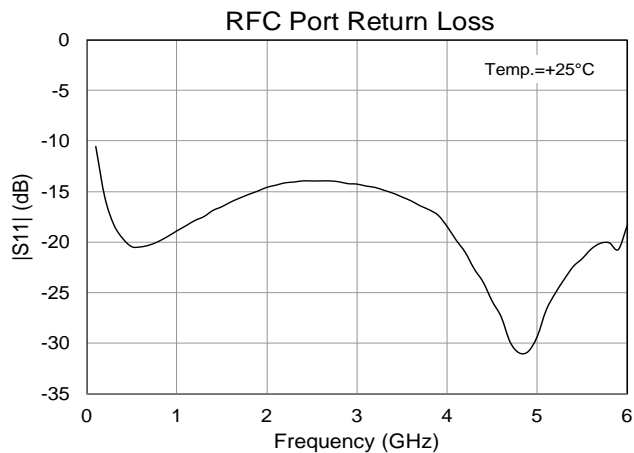
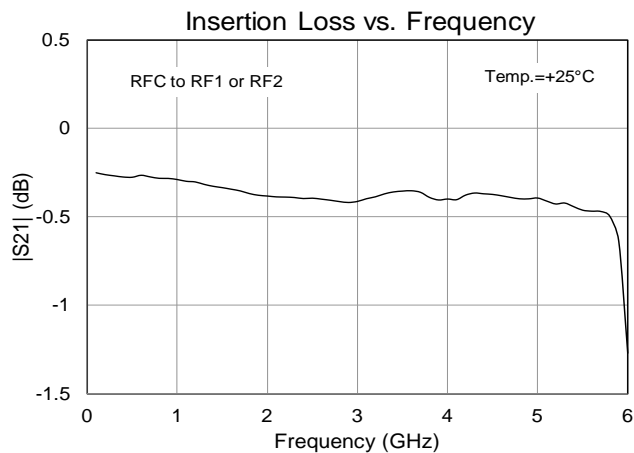

Pin Configuration and Description

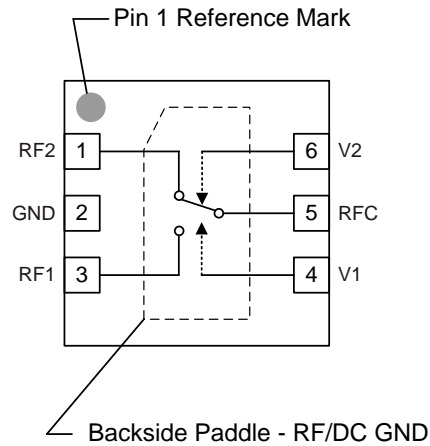

Pin No.	Symbol	Description
1	RF2	RF output 2, DC voltage present, DC block required.
2	GND	RF/DC Ground
3	RF1	RF output 1, DC voltage present, DC block required.
4	V1	Control Voltage
5	RFC	Antenna Input, DC voltage present, DC block required.
6	V2	Control Voltage
Backside Paddle	RF/DC GND	RF/DC Ground. Use recommended via pattern and ensure good solder attach for best thermal and electrical performance.

Mechanical Information

Package Marking and Dimensions

Marking: Part number – 08S7
 Year, week - YYWW
 Assembly code - XXXXX

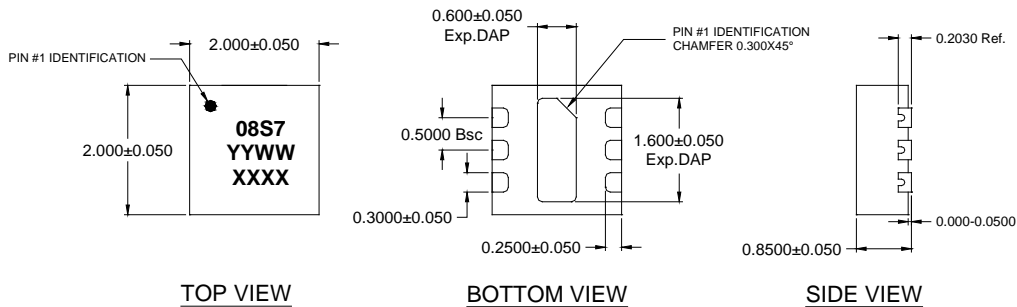

Notes:

1. All dimensions are in millimeters. Angles are in degrees.
2. Dimension and tolerance formats conform to ASME Y14.4M-1994.
3. The terminal #1 identifier and terminal numbering conform to JESD 95-1 SPP-012

PCB Mounting Pattern

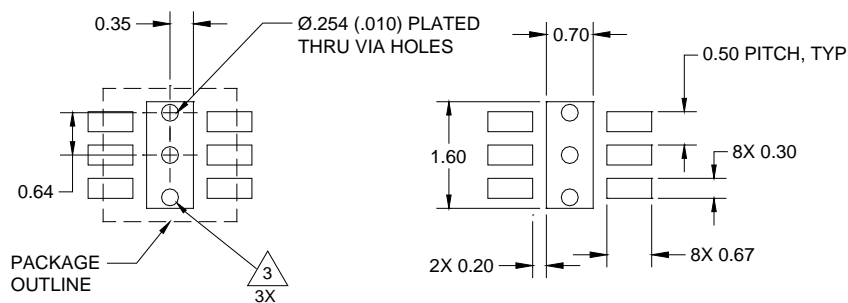

Notes:

1. All dimensions are in millimeters. Angles are in degrees.
2. Use 1 oz. copper minimum for top and bottom layer metal.
3. We recommend a 0.35mm (#80/.0135") diameter bit for drilling via holes and a final plated thru diameter of 0.25 mm (0.10").
4. Ensure good package backside paddle solder attach for reliable operation and best electrical performance.

Product Compliance Information**ESD Sensitivity Ratings****Caution! ESD-Sensitive Device**

ESD Rating: Class 1C (RF Ports)
Value: 1000 V to <2000 V
ESD Rating: Class 1B (DC Lines)
Value: 500 V to <1000 V
Test: Human Body Model (HBM)
Standard: JEDEC Standard JESD22-A114

ESD Rating: Class IV
Value: >1000 V
Test: Charged Device Model (CDM)
Standard: JEDEC Standard JESD22-C101

MSL Rating

MSL Rating: Level 1
Test: 260°C convection reflow
Standard: JEDEC Standard IPC/JEDEC J-STD-020

Solderability

Compatible with both lead-free (260°C max. reflow temperature) and tin/lead (245°C max. reflow temperature) soldering processes.

Package contact plating: NiPdAu

RoHS Compliance

This part is compliant with EU 2002/95/EC RoHS directive (Restrictions on the Use of Certain Hazardous Substances in Electrical and Electronic Equipment).

This product also has the following attributes:

- Lead Free
- Halogen Free (Chlorine, Bromine)
- Antimony Free
- TBBP-A (C₁₅H₁₂Br₄O₂) Free
- PFOS Free
- SVHC Free

Important Notice

For the latest specifications, additional product information, worldwide sales and distribution locations, and information about TriQuint:

Web: www.triquint.com **Tel:** +1.503.615.9000
Email: info-sales@triquint.com **Fax:** +1.503.615.8902

For technical questions and application information:

Email: sjapplications.engineering@triquint.com

Contact Information

The information contained herein is believed to be reliable. TriQuint makes no warranties regarding the information contained herein. TriQuint assumes no responsibility or liability whatsoever for any of the information contained herein. TriQuint assumes no responsibility or liability whatsoever for the use of the information contained herein. The information contained herein is provided "AS IS, WHERE IS" and with all faults, and the entire risk associated with such information is entirely with the user. All information contained herein is subject to change without notice. Customers should obtain and verify the latest relevant information before placing orders for TriQuint products. The information contained herein or any use of such information does not grant, explicitly or implicitly, to any party any patent rights, licenses, or any other intellectual property rights, whether with regard to such information itself or anything described by such information.

TriQuint products are not warranted or authorized for use as critical components in medical, life-saving, or life-sustaining applications, or other applications where a failure would reasonably be expected to cause severe personal injury or death.