

1.4MHz,30V/1.3A High Performance, Boost Converter

General Description

The LP3308 is a 1.4MHz PWM boost switching regulator designed for constant-voltage boost applications. The LP3308 can drive a string of up to 30V. The LP3308 implements a constant frequency 1.4MHz PWM control scheme. The high frequency PWM operation also saves board space by reducing external component sizes. To improve efficiency, the feedback voltage is set to 1230 mV, which reduces the power dissipation in the voltage setting resistor. Highly integration and internal compensation network minimizes as 5 external component counts. Optimized operation frequency can meet the requirement of small LC filters value and low operation current with high efficiency.

Ordering Information

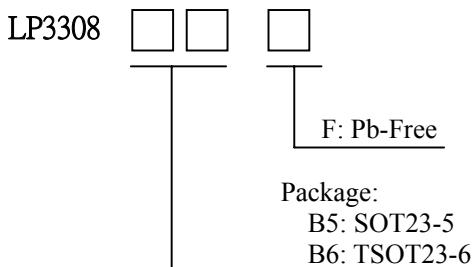

Pin Configurations

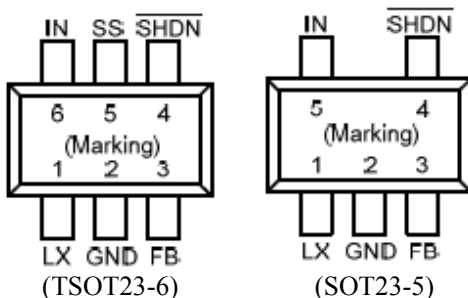

Features

- ✧ High Efficiency: 90%
- ✧ 1.4MHz Fixed-Frequency PWM Operation
- ✧ Maximum Output Voltage up to 30V
- ✧ Guaranteed 13V/200mA Output with 5V input
- ✧ Operating Range : 2.7V to 5.5V
- ✧ Shutdown Supply Current:<1uA
- ✧ Programmable Soft-star
- ✧ Available in TSOT23-6/SOT23-5 Package
- ✧ Minimize the External Component
- ✧ RoHS Compliant and 100% Lead (Pb)-Free

Applications

- ✧ Panel Bias Voltage supply
- ✧ OLED Backlight driver
- ✧ Notebook Computers
- ✧ Portable Applications
- ✧ MID/PTV

Typical Application Circuit

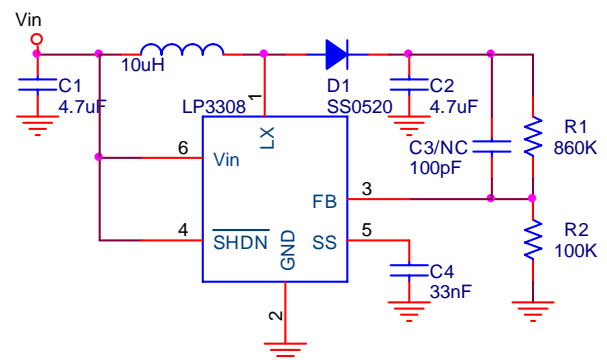

Marking information

Please view website.

Functional pin description

SOT-23-5	SOT-23-6	Pin Name	Pin Function
1	1	LX	Switch Pin. Connect this Pin to inductor and catch diode. Minimize the track area to reduce EMI.
2	2	GND	Ground Pin
3	3	FB	Feedback Reference Voltage Pin. Series connect a resistor between Vout and ground as a voltage sense. The feedback voltage is 1230mV.
4	4	/SHDN	Chip Enable (Active High). Voltage sensing input to trigger the function of over voltage protection. Note that this pin is high impedance. There should be a pull low 100k Ω resistor connected to GND when the control signal is floating.
	5	SS	Softstar pin. Leave SS open to disable the soft-star function.
5	6	Vin	Supply Input Voltage Pin. Bypass 1uF capacitor to GND to reduce the input noise.

Function Block Diagram

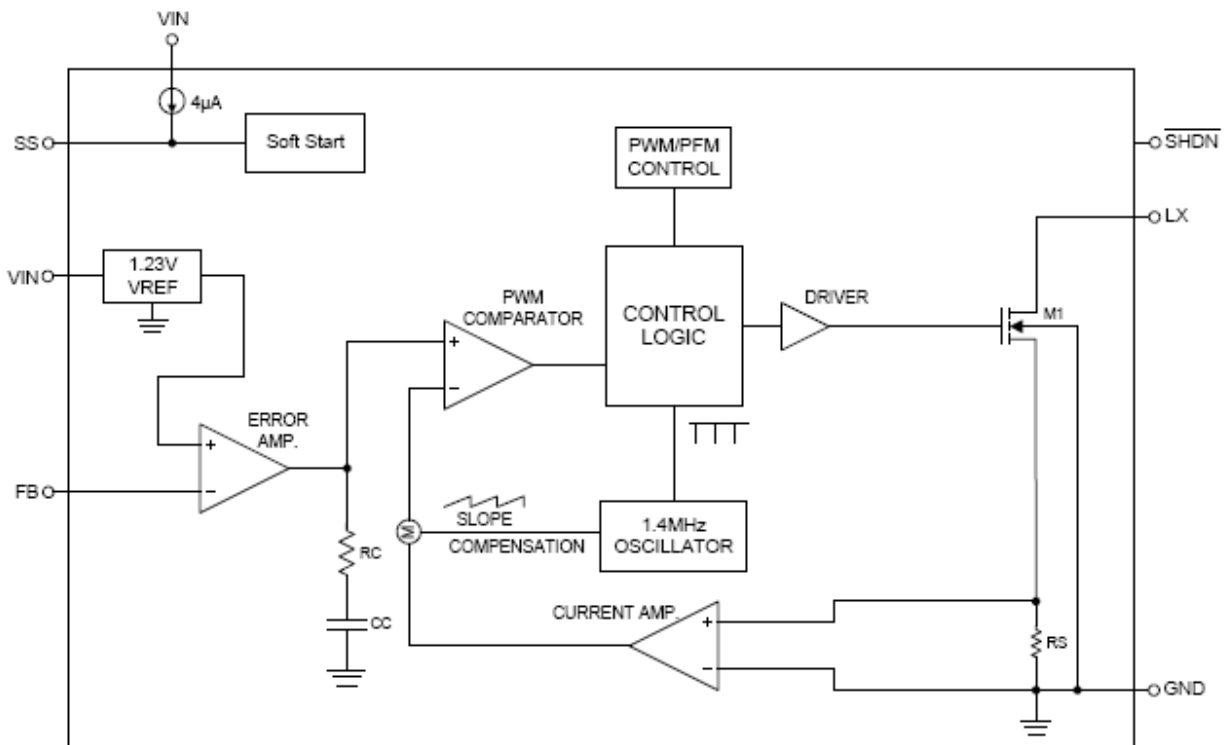

Absolute Maximum Ratings

Supply Input Voltage-----0.3V to 6.0V
 LX Input Voltage -----0.3V to 33V
 The Other Pins -----0.3V to 5.5V
 Power Dissipation, P_D @ T_A = 25°C TSOT-23-5/6-----0.455W
 Lead Temperature (Soldering, 10 sec.) ----- 260°C
 Operation Temperature Range -----40°C to 80°C
 Storage Temperature Range -----65°C to 150°C

Electrical Characteristics

Parameter	Symbol	Test Condition	Min	Typ.	Max	Units
System Supply Input						
Operation voltage Range	VDD		2.7		6	V
Under Voltage Lock Out	VDD		2.2	2.4	2.6	V
Supply Current	IDD	FB=0.2V, Switch		430	550	uA
Shut Down Current	IDD	VEN < 0.4V		0.1	1	uA
Line Regulation		VIN : 3.0~4.3V		2		%
Oscillator						
Operation Frequency	FOSC			1.4		MHz
Maximum Duty Cycle			93			%
Feedback Voltage	LP3308		1.21	1.23	1.255	V
MOSFET						
On Resistance of MOSFET	RDS(ON)			0.7		Ω
SW Current Limit	ILM			1.4		A
Protection						
Shut Down Voltage	VEN		0.3			V
Enable on Voltage	VEN				1.0	V

Typical Operating Characteristics

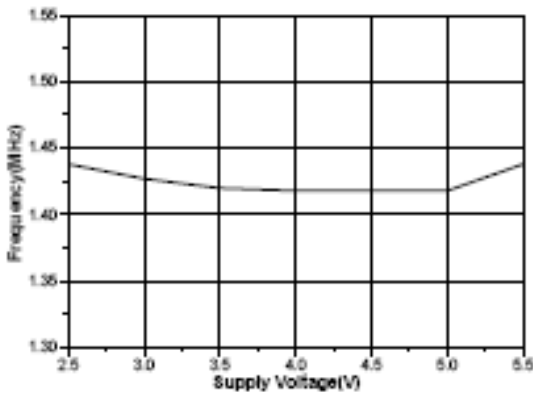

Figure 6. Frequency vs. Supply Voltage

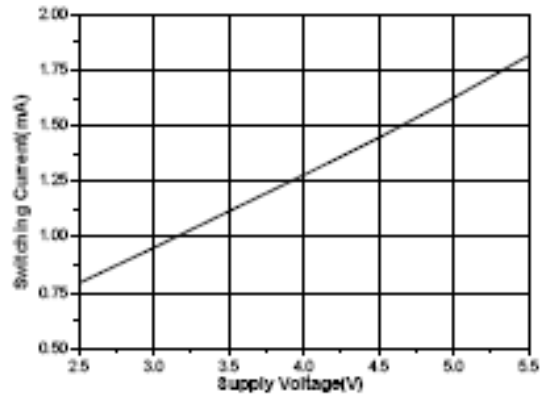

Figure 7. Switching Current vs. Supply Voltage

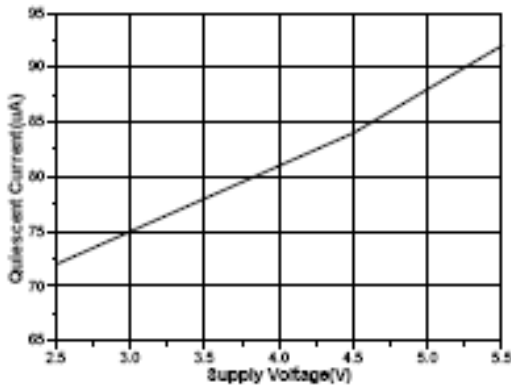

Figure 8. Non-Switching Current vs. Supply Voltage

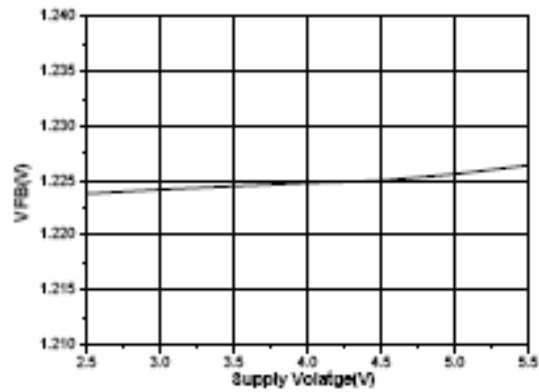

Figure 9. Feedback Voltage vs. Supply Voltage

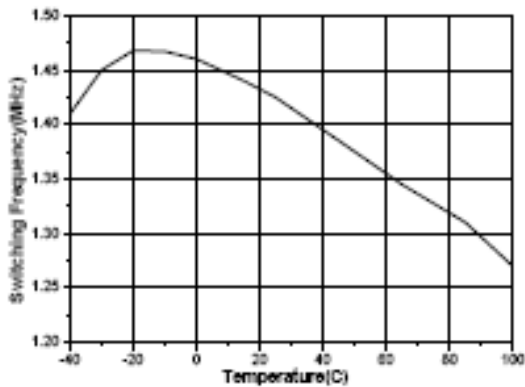

Figure 10. Switching Frequency vs. Temperature

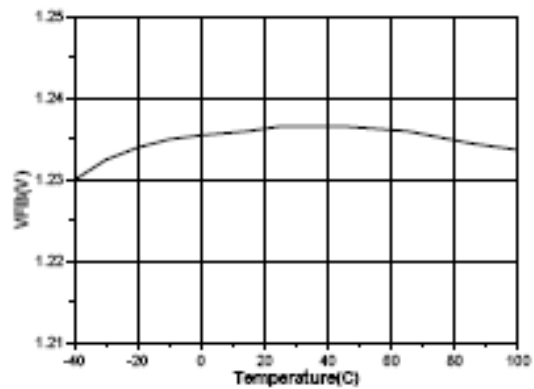

Figure 11. Feedback Voltage vs. Temperature

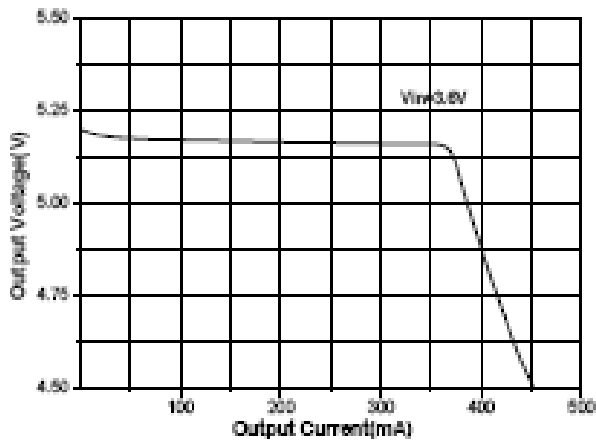

Figure 12. Load Regulation ($V_o=5V$)

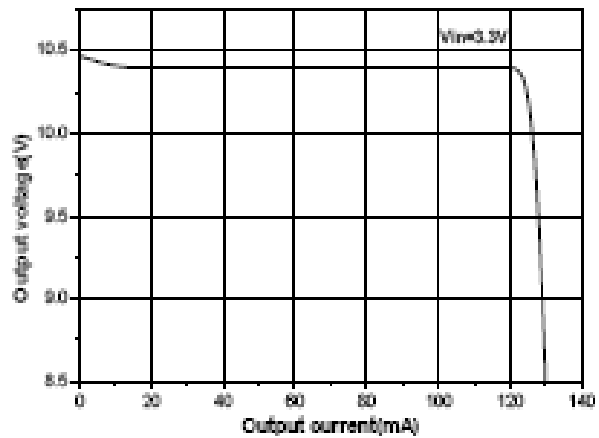

Figure 13. Load Regulation ($V_o=10V$)

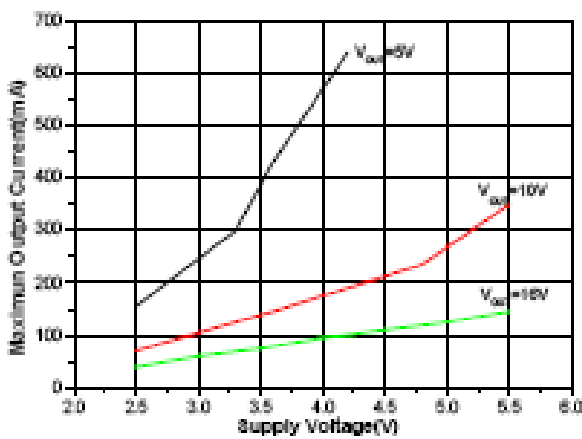

Figure 14. Maximum Output Current vs. Supply Voltage

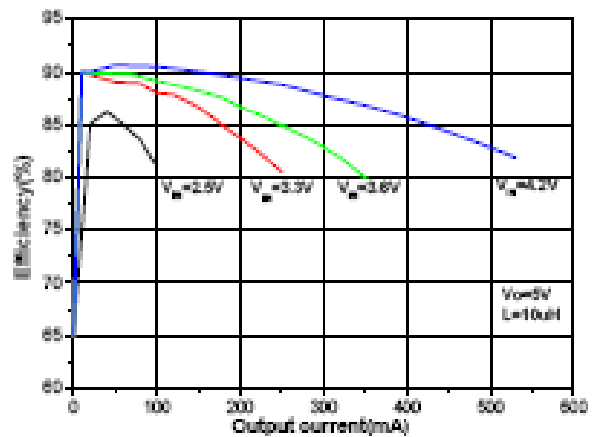

Figure 15. Efficiency vs. Output Current ($V_o=5V$)

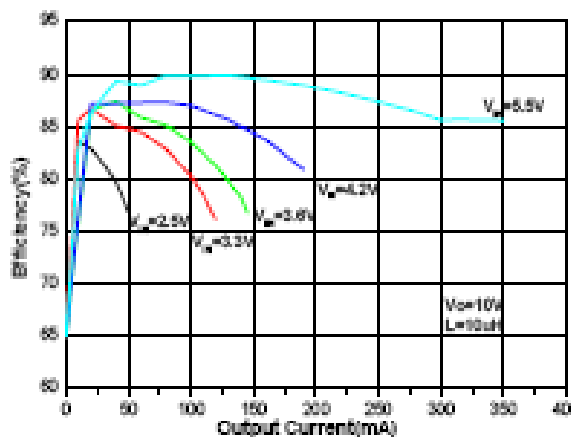

Figure 16. Efficiency vs. Output Current ($V_o=10V$)

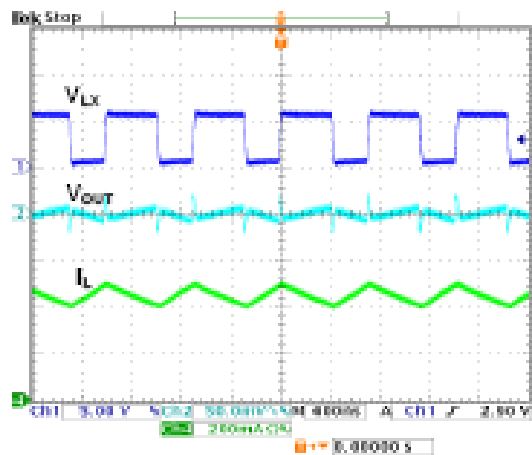
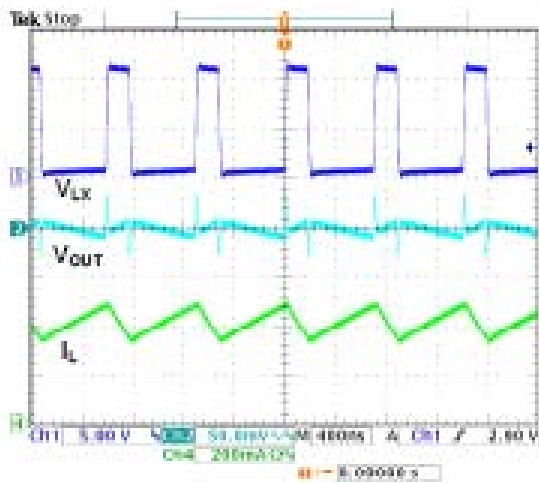
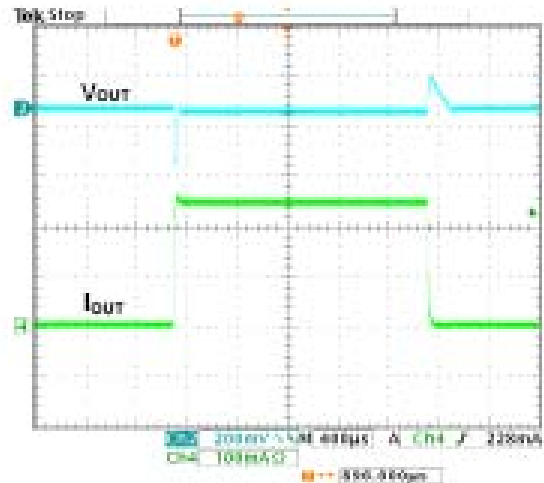

Figure 17. Operation Waveform



$V_{IN}=3.3V, V_o=10V, I_o=100mA, L1=10\mu H$

Figure 18. Operation Waveform



$V_{IN}=3.6V, V_o=5V, I_o=5 \text{ to } 250mA, CFF=220pF$

Figure 19. Load Step Response

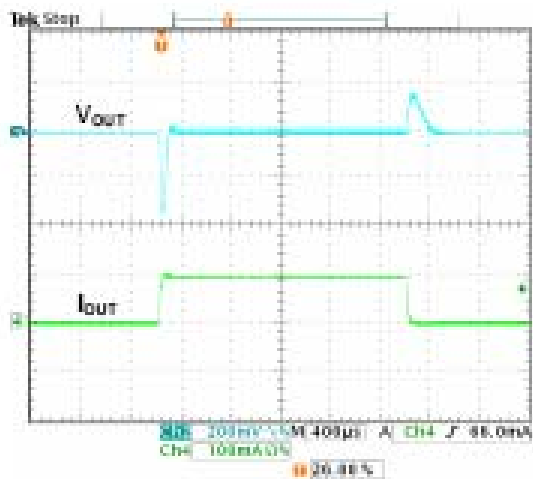

$V_{IN}=3.3V, V_o=10V, I_o=5 \text{ to } 250mA, CFF=220pF$

Figure 20. Load Step Response

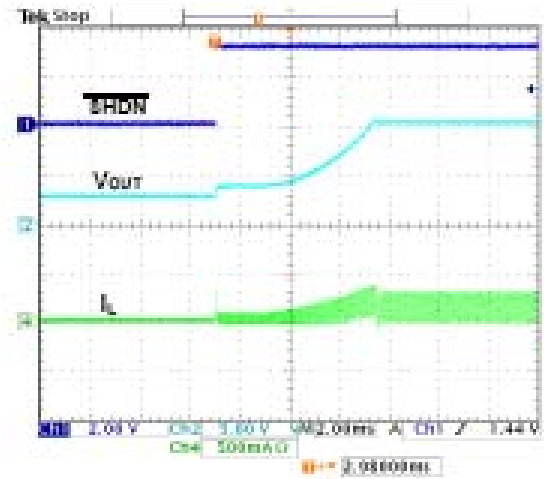

$V_{IN}=3.3V, V_{OUT}=10V, I_o=50mA, C88=33nF$

Figure 21. Start-Up from Shutdown

Applications Information

Inductor Selection

The recommended value of inductor for 30V applications are 4.7 to 22 μ H. Small size and better efficiency are the major concerns for portable device, such as LP3308 used for mobile phone. The inductor should have low core loss at 1.4MHz and low DCR for better efficiency. To avoid inductor saturation current rating should be considered.

Packing information

TSOT23-5

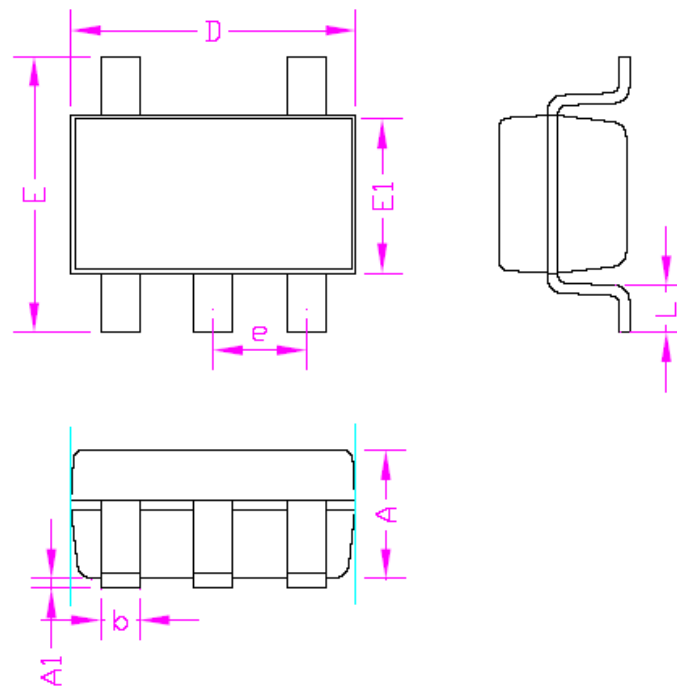

SYMBOLS	MILLIMETERS		INCHES	
	MIN.	MAX.	MIN.	MAX.
A	-	1.00	-	0.039
A1	0.00	0.15	0.000	0.006
D	2.90		0.114	
E1	1.60		0.063	
E	2.60	3.00	0.102	0.118
L	0.30	0.60	0.012	0.024
b	0.30	0.50	0.012	0.020
e	0.95		0.037	

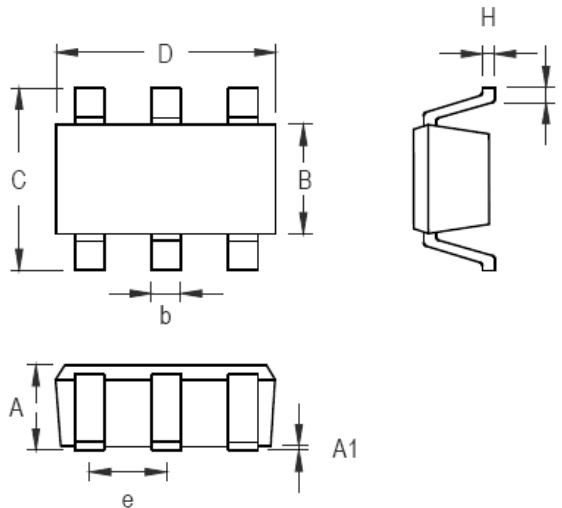

Symbol	Dimensions In Millimeters		Dimensions In Inches	
	Min	Max	Min	Max
A	0.700	1.000	0.028	0.039
A1	0.000	0.100	0.000	0.004
B	1.397	1.803	0.055	0.071
b	0.300	0.559	0.012	0.022
C	2.591	3.000	0.102	0.118
D	2.692	3.099	0.106	0.122
e	0.838	1.041	0.033	0.041
H	0.080	0.254	0.003	0.010
L	0.300	0.610	0.012	0.024

TSOT-23-6 Surface Mount Package