



Micro Commercial Components
21201 Itasca Street Chatsworth
CA 91311
Phone: (818) 701-4933
Fax: (818) 701-4939

SM03 THRU SM36

Features

- SOT-23 Package For surface mount application
- Protects 3.0/3.3 up through 36V Components
- Protects 2 Unidirectional or 1 Bidirectional line
- Provides electrically isolated protection
- Tape & Reel EIA Standard 481.

Mechanical Data

- Molded: SOT-23 Surface Mount
- Body marked with device number.
- Mounting Position: Any
- Weight: 0.14 grams (approx.)

MAXIMUM RATINGS

- Operating Temperature: -55°C to +150°C
- Storage Temperature: -55°C to +150°C
- SM03 thru SM36 have a Peak Pulse Power: 500 Watts (8/20 usec, Figure 1)
- Pulse Repetition Rate: <.01%

Packaging

The SM03 thru SM36 product provides board level protection from static electricity and other induced-voltage surges that can damage sensitive circuitry.

These TRANSIENT VOLTAGE SUPPRESSOR (TVS) Diode Arrays protect 3.0/3.3 Volt components such as DRAM's, SRAM's, COMS, HCOMS, HSIC, and low volt. interfaces up to 36 volts. Because of the physical size, weight and protection capabilities, this product is ideal for use in but not limited to miniaturized electronic equipment such as hand held instruments, computers, computer peripherals and cell phones.

Transient Voltage Suppressor 500 Watt

SOT-23

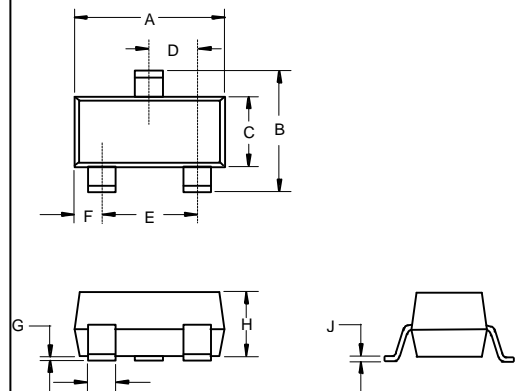

DIM	INCHES		MM		NOTE
	MIN	MAX	MIN	MAX	
A	.110	.120	2.80	3.04	
B	.083	.098	2.10	2.64	
C	.047	.055	1.20	1.40	
D	.035	.041	.89	1.03	
E	.070	.081	1.78	2.05	
F	.018	.024	.45	.60	
G	.0005	.0039	.013	.100	
H	.035	.044	.89	1.12	
J	.003	.007	.085	.180	
K	.015	.020	.37	.51	

Suggested Solder Pad Layout

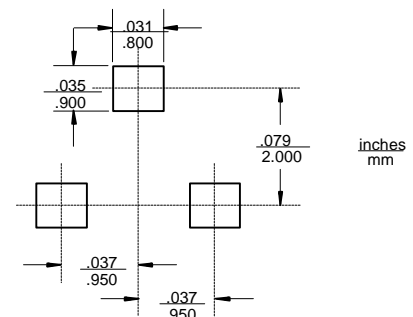

SM03 thru SM36

NOTE: Transient Voltage Suppression (TVS) product is normally selected based on its stand off Voltage V_{WM} . Product selected voltage should be equal to or greater than the continuous peak operating voltage of the circuit to be protected.

WAVE FORMS

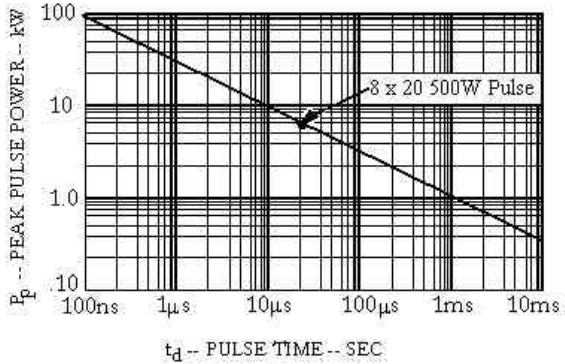

FIGURE 1
Peak Pulse Power Vs Pulse Time

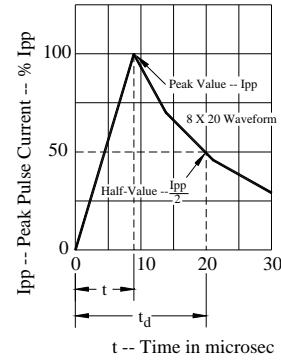
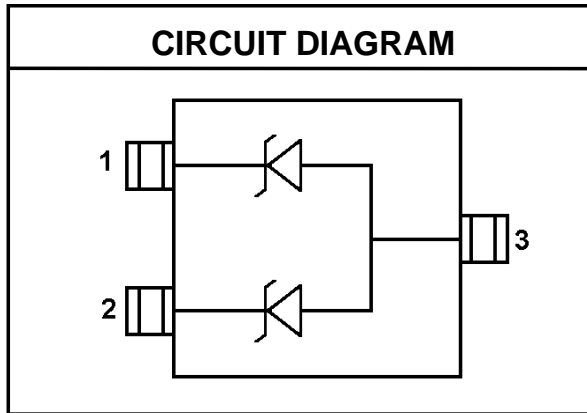
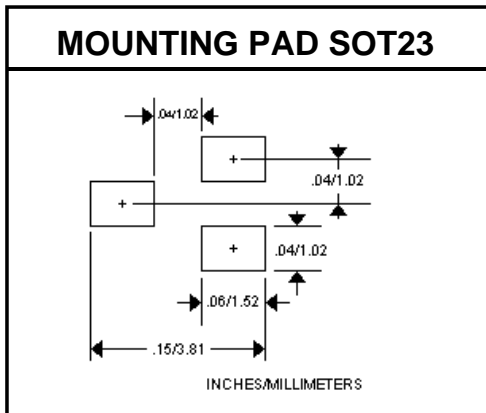

FIGURE 2
Pulse Wave Form



ELECTRICAL CHARACTERISTICS PER LINE @ 25°C Unless otherwise specified

PART NUMBER	DEVICE MARKING	STAND OFF VOLTAGE V_{WM}	BREAKDOWN VOLTAGE V_{BR} @ 1 mA	CLAMPING VOLTAGE V_C @ 1 Amp (FIGURE 2)	CLAMPING VOLTAGE V_C @ 5 Amp (FIGURE 2)	LEAKAGE CURRENT I_D @ V_{WM}	CAPACITANCE @ 0V, 1 MHz C Pin 1-3 or 2-3	CAPACITANCE @ 0V, 1 MHz C Pin 1-2
		VOLTS	VOLTS	VOLTS	VOLTS	μA	pF	pF
			MIN	MAX	MAX	MAX	MAX	MAX
SM03	M03	3.3	4	7	9	200	800	400
SM05	M05	5.0	6.0	9.8	11	100	600	300
SM12	M12	12.0	13.3	19	24	1	185	93
SM15	M15	15.0	16.7	24	30	1	140	70
SM24	M24	24.0	26.7	43	55	1	88	44
SM36	M36	36.0	40.0	60	75	1	88	39

NOTE: Transient Voltage Suppression (TVS) product is normally selected based on its stand off Voltage V_{WM} . Product selected voltage should be equal to or greater than the continuous peak operating voltage of the circuit to be protected.