

Dual-Channel Laser Diode Driver with APC Amplifier for Multi-Beam Printers

ISL58125

The ISL58125 is a high-performance dual channel laser driver that provides controlled current to grounded laser diodes. A bias current is summed with the switched current at the IOUT output, allowing the user to optimize laser diode performance.

Output switched current flows when the LVDS signal DATA is high. The output current returns to the fixed-threshold value when DATA is low. Complete I_{OUT} shut-off is achieved by holding both of the DISx pins Hi, which will override all other control pins.

A fast settling APC amplifier connects directly to the monitor diode. The ISL58125 does not exhibit any time-dependent droop since the calibration gain is stored as a digital number.

Ordering Information

PART NUMBER (Note)	PART MARKING	PACKAGE Tape & Reel (Pb-free)	PKG. DWG. #
ISL58125CRZ-T13	58125 CRZ	28 Ld QFN	L28.4x5A

- Please refer to TB347 for details on reel specifications.
- These Intersil Pb-free plastic packaged products employ special Pb-free material sets, molding compounds/die attach materials, and 100% matte tin plate plus anneal (e3 termination finish, which is RoHS compliant and compatible with both SnPb and Pb-free soldering operations). Intersil Pb-free products are MSL classified at Pb-free peak reflow temperatures that meet or exceed the Pb-free requirements of IPC/JEDEC J STD-020.
- For Moisture Sensitivity Level (MSL), please see device information page for [ISL58125](#). For more information on MSL please see techbrief [TB363](#).

Features

- Voltage-controlled Output Current Source
- Very Few External Components Needed
- Internal LVDS Termination Resistors
- 300MHz Switching
- 110mA Output Current per channel
- Rise Time < 500ps
- Fall Time < 500ps
- APC Loop for Write Power Control
- Fast Settling APC Amplifier
- Single +5V Supply ($\pm 10\%$)
- Disable Feature for Power-Up Protection and Conserving Power
- Zero Droop
- Pb-Free (RoHS compliant)

Load Configuration

- Common-cathode LDs, Common-anode PD

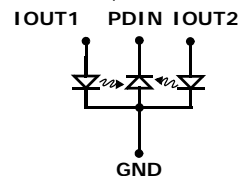

Applications

- Laser Printer Applications
- Laser Diode Current Switching

Pin Configuration

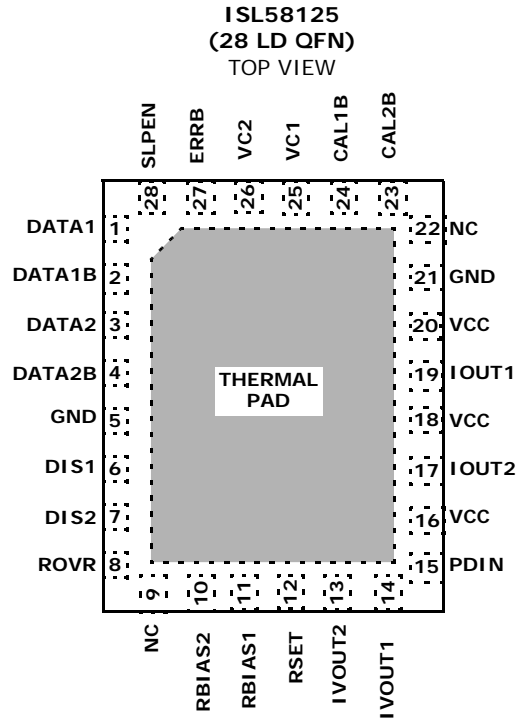

Pin Descriptions

PIN NAME	I/O	TYPE	DESCRIPTION
DATA1	I	LVDS	Laser #1 Switching Control
DATA1B	I	LVDS	Laser #1 Switching Control
DATA2	I	LVDS	Laser #2 Switching Control
DATA2B	I	LVDS	Laser #2 Switching Control
GND		Ground	Ground
DIS1	I	Digital	DIS1 = Low selects IOOUT1
DIS2	I	Digital	DIS2 = Low selects IOOUT2
VC1	I	Analog	Voltage Controlling Laser #1 Switching Current; 0V to 2V input for 0% to 100% output
VC2	I	Analog	Voltage Controlling Laser #2 Switching Current
NC		No Connect	No Connect
ERRB	O	Open drain	ERRB = Low when output current is max OR Overheat OR Under Supply Voltage
IVOUT1 IVOUT2	O	Analog	Calibrate channel with an external trimpot to GND Adjust the IV amplifier gain
RSET	O	Analog	Bandgap derived internal reference
ROVR	I	Analog	Resistor sets the peak current at which the error pin ERRB is pulled.
PDIN	I	Analog	Photo Diode input to the IV amplifier
RBIAS1 RBIAS2		Analog	Resistors set bias threshold current. See "Applications Information" on page 8 for more details.
IOOUT2	O	Analog	Laser #2 Current Output
IOOUT1	O	Analog	Laser #1 Current Output
VCC		Power	Supply Voltage
CAL1B	I	TTL	Samples the laser #1 for APC; Active Low
CAL2B	I	TTL	Samples the laser #2 for APC; Active Low
SLPEN	I	TTL	Enable sleep mode when SLPEN = DISx = Hi
Thermal Pad			Exposed Thermal Pad should be soldered to GND

NOTE: Pins with the same name are not necessary internally connected together. LDD pins must not be used for connecting together external components or features.

ISL58125

Absolute Maximum Ratings (T_A = +25°C)

Voltages Applied to:

V _{CC}	-0.5V to 6.0V
All Inputs	-0.5V to V _{CC} + 0.5V
I _{OUT}	-0.5V to V _{CC}
LVDS Max Current Inputs	5mA

ESD Rating

Human Body Model	3kV
Charged Device Model	1.5kV

Recommended Operating Conditions

Thermal Resistance (Typical, Note 4)	θ _{JA} (°C/W)
28 Lead QFN	42
Operating Ambient Temperature Range	0°C to +85°C
Maximum Junction Temperature	+150°C
Storage Temperature Range	-65°C to +150°C
Pb-Free Reflow Profile	see link below
	http://www.intersil.com/pbfree/Pb-FreeReflow.asp

CAUTION: Do not operate at or near the maximum ratings listed for extended periods of time. Exposure to such conditions may adversely impact product reliability and result in failures not covered by warranty.

NOTE:

- θ_{JA} is measured in free air with the component mounted on a high effective thermal conductivity test board with "direct attach" features. See Tech Brief TB379.

IMPORTANT NOTE: All parameters having Min/Max specifications are guaranteed. Typical values are for information purposes only. Unless otherwise noted, all tests are at the specified temperature and are pulsed tests, therefore: T_J = T_C = T_A

Standard Specification Conditions: Unless otherwise indicated, all tables are: V_{CC} = 5.0V, DIS = Lo, T_A = +25°C, R_{SET} = 3.0kΩ

Electrical Specifications Standard conditions, and/or as noted.

PARAMETER	DESCRIPTION	CONDITIONS	MIN (Note 5)	TYP	MAX (Note 5)	UNIT
V _{CC}	Supply Voltage		4.5	5.0	5.5	V
I _{Sdis}	Supply Current (Disabled)	DISx = SLPEN = Hi		0.3	1.0	mA
I _{S2}	Supply Current (Standby)	DISx = Hi		22	31	mA
V _{LO}	Low Voltage Threshold	All TTL inputs			1.2	V
V _{HI}	High Voltage Threshold	All TTL inputs	2.8			V
I _{LO}	Input Low Current	All TTL inputs	-20	-10		μA
I _{HI}	Input High Current	All TTL inputs			1	μA
V _{SHUT}	VCC Shut Down Voltage			2.5	2.9	V
V _{LVDS}	LVDS Input Level	Differential, with V _{cm} = 1.25V		0.2		V
V _{CMR}	LVDS Common Mode Voltage Range	300mV _{p-p}	0.2		2.2	V
V _C	Control Voltage		0.3		2.6	V
R _{Termination}	Internal LVDS Termination Resistor			180		Ω
EERB						
V _{outLOW}	Digital Output Sink Capability	ERRB pin, sinking 5mA		0.4		V
I _{OVR-2k}	Overcurrent trip point	ROVR = 2kΩ, ERRB pin goes low		43		mA
V _{CCUNR}	Undervoltage Trip Point	ERRB pin goes low, No I _{OUT} current		2.6		V

Laser Amplifier Output Standard conditions and/or as noted.

PARAMETER	DESCRIPTION	CONDITIONS	MIN (Note 5)	TYP	MAX (Note 5)	UNIT
I_{OUT}						
I _{OUTSW-max}	Switched Output Current	V _C = 2.6V	75	81		mA
I _{OUTBIAS-max}	Bias Output Current	R _{BIAS} = 1kΩ	20	35		mA
I _{OFF}	Output Off Current	DISx pins set to HIGH	-75	0	+75	μA
FREQ _{OP}	Operating Frequency	I _{OUT} = maximum switch current	200			MHz

Laser Amplifier Output Standard conditions and/or as noted. (Continued)

PARAMETER	DESCRIPTION	CONDITIONS	MIN (Note 5)	TYP	MAX (Note 5)	UNIT
I _{OUT} PSRR	I _{OUT} Supply Sensitivity	I _{OUT} = 20mA, V _{CC} = 5V ±10%		13		%/V
t _{R-IOUT}	I _{OUT} Rise Time	10% to 90%; typical LD for printer		0.5		ns
t _{F-IOUT}	I _{OUT} Fall Time	90% to 10%; typical LD for printer		0.7		ns
OUTENx_t _{on}	I _{OUT} on Propagation Delay	DATAx crossing to I _{OUT} at 50% of final value		5	7	ns
VC						
t _{PD_VC-IOUT}	Propagation Time of VC	0.75V to 1.25V step		16		ns
t _{R_VC-IOUT}	Rise Time of I _{OUT} from VC	10% to 90%; resistive load, R _{LOAD} = 10Ω		25		ns
t _{F_VC-IOUT}	Fall Time of I _{OUT} from VC	90% to 10%; resistive load, R _{LOAD} = 10Ω		22		ns
VC _{BW}	Bandwidth of VC			14		MHz

APC Electrical Specifications Standard conditions and/or as noted.

PARAMETER	DESCRIPTION	CONDITIONS	MIN (Note 5)	TYP	MAX (Note 5)	UNIT
t _{APC-50}	APC Response Time	0V to 2V step of VC		7.5		μs
IV _{gain}	IV Amplifier Gain	External resistor R _{IV} = 500Ω		3.1		kΩ

NOTE:

- Parameters with MIN and/or MAX limits are 100% tested at +25°C, unless otherwise specified. Temperature limits established by characterization and are not production tested.

Timing Diagram

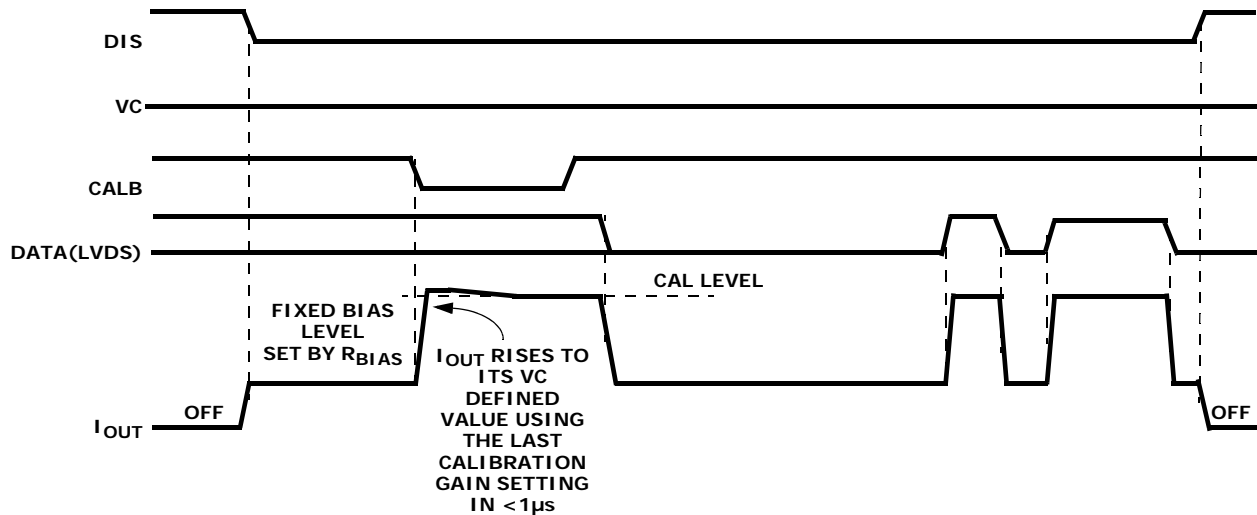

I_{OUT} Control

DIS1	DIS2	DATA1	DATA2	CAL1	CAL2	SLPEN	I _{OUT1}	I _{OUT2}
Power-Down (Sleep Mode)								
1	1	x	x	x	x	1	OFF	OFF
Standby (Full Standby Current, No I_{OUTs})								
1	1	x	x	x	x	0	OFF	OFF
Normal Drive								
0	1	0	0	1	1	0	ON, BIAS ONLY	OFF
1	0	0	0	1	0	0	OFF	ON, BIAS ONLY
0	0	x	x	0	1	x	ON, CAL to level set by VC	OFF
0	0	x	x	1	0	x	OFF	ON, CAL to level set by VC
0	0	1	1	1	1	x	ON	ON
0	1	1	1	1	1	x	ON	OFF
1	0	1	1	1	1	x	OFF	ON

NOTE: DATA1 and DATA2: 1 implies DATA>DATAB, 0 implies DATA<DATAB

Typical Application

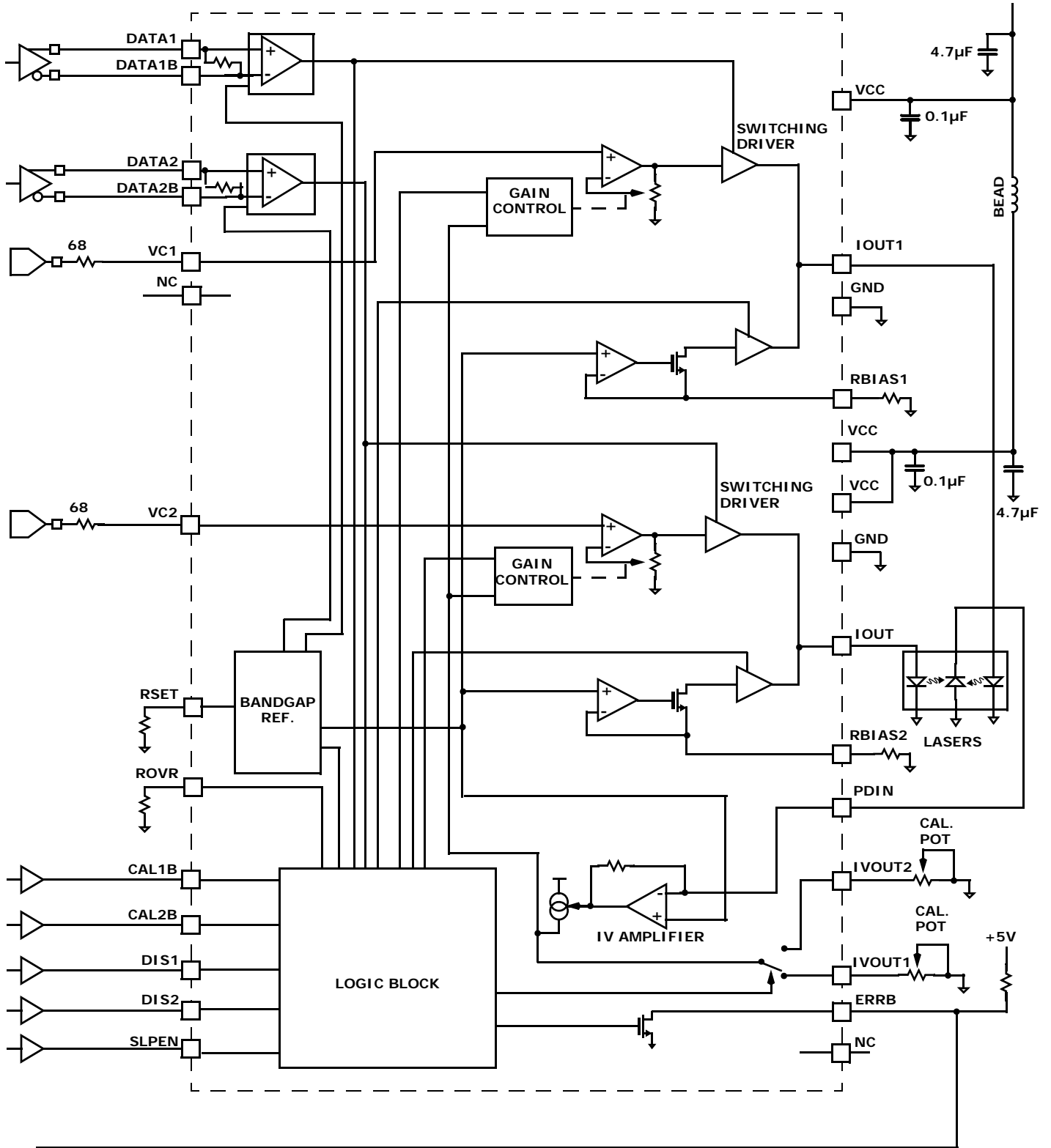

Applications Information

APC System Overview

As the laser heats up, or ages, its output power declines relative to the applied current, so some form of power control is required. The laser is optically coupled to a photo-diode, so that the laser's optical output can be measured. Laser optical output power is controlled by comparing the externally applied control voltage with the voltage produced by the IV-amplifier which converts the photo-diode's output current into a voltage. Since the calibrated gain is stored as a digital number in a register, the ISL58125 exhibits none of the time-dependent droop that is seen in most printers' laser diode drivers. This is of particular importance during high dot/inch graphics modes where the line may be slowed down very significantly to allow 2400 dots per inch or even more.

Fixed-Threshold Laser Bias Control

When a laser is driven from below threshold to well above threshold, it exhibits a few cycles of a damped oscillation. The amplitude of this oscillation is minimized when the laser is kept above threshold. The "fixed" bias mode is set by asserting a logic Low on the SLPEN pin. To set the laser bias threshold currents, I_{BIAS} , connect external resistors from R_{BIAS} pins to GND. Figure 1 shows value of R_{BIAS} corresponding to desired bias current.

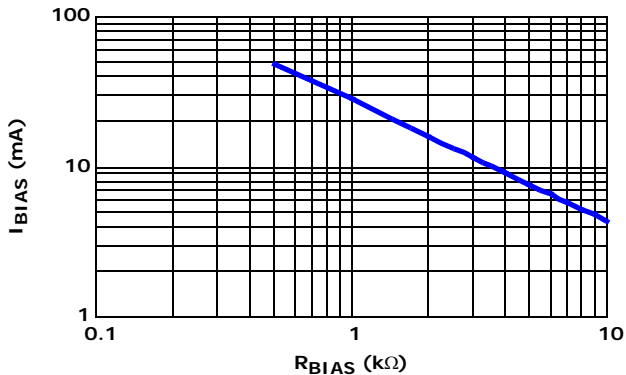

FIGURE 1. R_{BIAS} vs BIAS CURRENT

Scaling External Resistors

R_{SET} is used to scale the switching output current. Switching output current, I_{SW}, is the function of VC and R_{SET}

$$I_{SW} = I_{SWGain} \times \left(\frac{VC}{R_{DAC}} - \frac{2}{R_{SET}} \right) \quad (EQ. 1)$$

Where I_{SWGain} = ~17, R_{DAC} = 400Ω

R_{BIAS} sets bias threshold current. Figure 1 exhibits the relationship between I_{BIAS} and R_{BIAS}. The bias current is set as Equation 2:

$$I_{BIAS} = BiasChannelGain \times \frac{InternalVref}{R_{BIAS}} \quad (EQ. 2)$$

Where BiasChannelGain = ~40, InternalVref = 1.0V.

R_{OV} resistor defines the maximum current that can flow in either laser before the ERRB pin puts out a logical

LOW. This can be used to detect fault conditions. Since both channel's overcurrent detectors are ORed together, ERRB going low could indicate a fault in either or both output channels. Note that the ISL58125 does not shut itself down when an overcurrent condition is detected. The device controller is expected to take any required action. The maximum current is governed by Equation 3:

$$I_{TRIP} = \frac{1.05V}{(R_{OV} \times 0.012)} \text{Amp} \quad (EQ. 3)$$

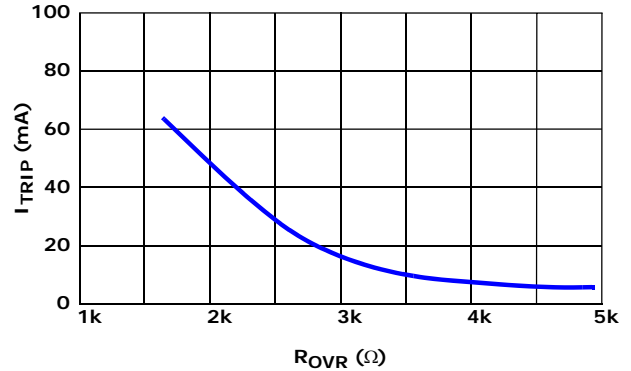

FIGURE 2. R_{OV} vs I_{TRIP} CURRENT

Controlling the Sampling

The switching levels are sampled independently. This can be done during the "off-paper" period.

During calibration mode, the internal servo control will bring the laser diode output power level to match the voltage control level set by VC voltage.

Typical Application

Upon the printer being powered up, the lasers should be calibrated. This would establish nominal light power outputs, typically a few milliwatts at the laser regardless of the ambient temperature and also any laser aging.

Once everything is ready for printing, the paper is in position and the mirror-motor is phase-locked then the print line(s) can be written. Before, or after, the beam is over the photo-sensitive drum, each laser can be re-calibrated. This continual re-calibration will compensate for any temperature drift of the laser, especially at the initial warming up period.

Since the calibrated gain is stored as a digital number in a register, the ISL58125 exhibits no time-dependent droop. With no droop to degrade performance the only limitation now is the lasers' own temperature change along the line. This in turn can be compensated for to some extent by adding a data-dependent compensation signal to the analog VCx input pin. It may be found that in fast draft modes for example, that the laser temperature change is sufficiently small that many lines can be written before the laser(s) need to be re-calibrated. If the printed page has a low enough duty cycle, no re-calibration may be needed at all.

The ISL58125 has analog voltage inputs to allow the laser power level to be adjusted during the line. Typically this would be driven with a PWM, low bandwidth signal to

compensate for the differing beam path length as the beam is swept from one side of the page to the other.

Undervoltage, overcurrent and over-temperature error conditions are ORed together and made available on the ERRB pin.

Power Supply Decoupling

Due to the high values of current being switched rapidly on and off, it is important to ensure that the power supply is well decoupled to ground. During switching, the V_{CC} undergoes severe current transients, thus every effort should be made to decouple the V_{CC} as close to the package as possible. Symptoms that could arise include poor rise/fall times, current overshoot, and poor settling response. It is recommended that V_{CC} inputs should be bypassed with $4.7\mu\text{F} // 100\text{nF} // 470\text{pF}$ to GND.

Inductance will be in series with the decoupling capacitor at the rate of about 0.6nH/mm of trace or capacitor distance. Thus for a 3mm loop from V_{CC} through the capacitor to ground, 300mA in 1ns will produce 540mV transient on the V_{CC} -GND voltage.

For additional products, see www.intersil.com/product_tree

Intersil products are manufactured, assembled and tested utilizing ISO9000 quality systems as noted in the quality certifications found at www.intersil.com/design/quality

Intersil products are sold by description only. Intersil Corporation reserves the right to make changes in circuit design, software and/or specifications at any time without notice. Accordingly, the reader is cautioned to verify that data sheets are current before placing orders. Information furnished by Intersil is believed to be accurate and reliable. However, no responsibility is assumed by Intersil or its subsidiaries for its use; nor for any infringements of patents or other rights of third parties which may result from its use. No license is granted by implication or otherwise under any patent or patent rights of Intersil or its subsidiaries.

For information regarding Intersil Corporation and its products, see www.intersil.com

Revision History

The revision history provided is for informational purposes only and is believed to be accurate, but not warranted. Please go to web to make sure you have the latest Rev.

DATE	REVISION	CHANGE
7/22/13	FN6625.1	Updated datasheet by removing Confidential Watermark, changing Logo, removed side bar with part number, copyright on page 1 and changed Product Information verbiage to About Intersil verbiage on page 14.
11/11/09	FN6625.0	Initial Release.

About Intersil

Intersil Corporation is a leader in the design and manufacture of high-performance analog, mixed-signal and power management semiconductors. The company's products address some of the largest markets within the industrial and infrastructure, personal computing and high-end consumer markets. For more information about Intersil, visit our website at www.intersil.com.

For the most updated datasheet, application notes, related documentation and related parts, please see the respective product information page found at www.intersil.com. You may report errors or suggestions for improving this datasheet by visiting www.intersil.com/en/support/ask-an-expert.html. Reliability reports are also available from our website at <http://www.intersil.com/en/support/qualandreliability.html#reliability>

Package Outline Drawing

L28.4x5A

28 LEAD QUAD FLAT NO-LEAD PLASTIC PACKAGE

Rev 2, 06/08

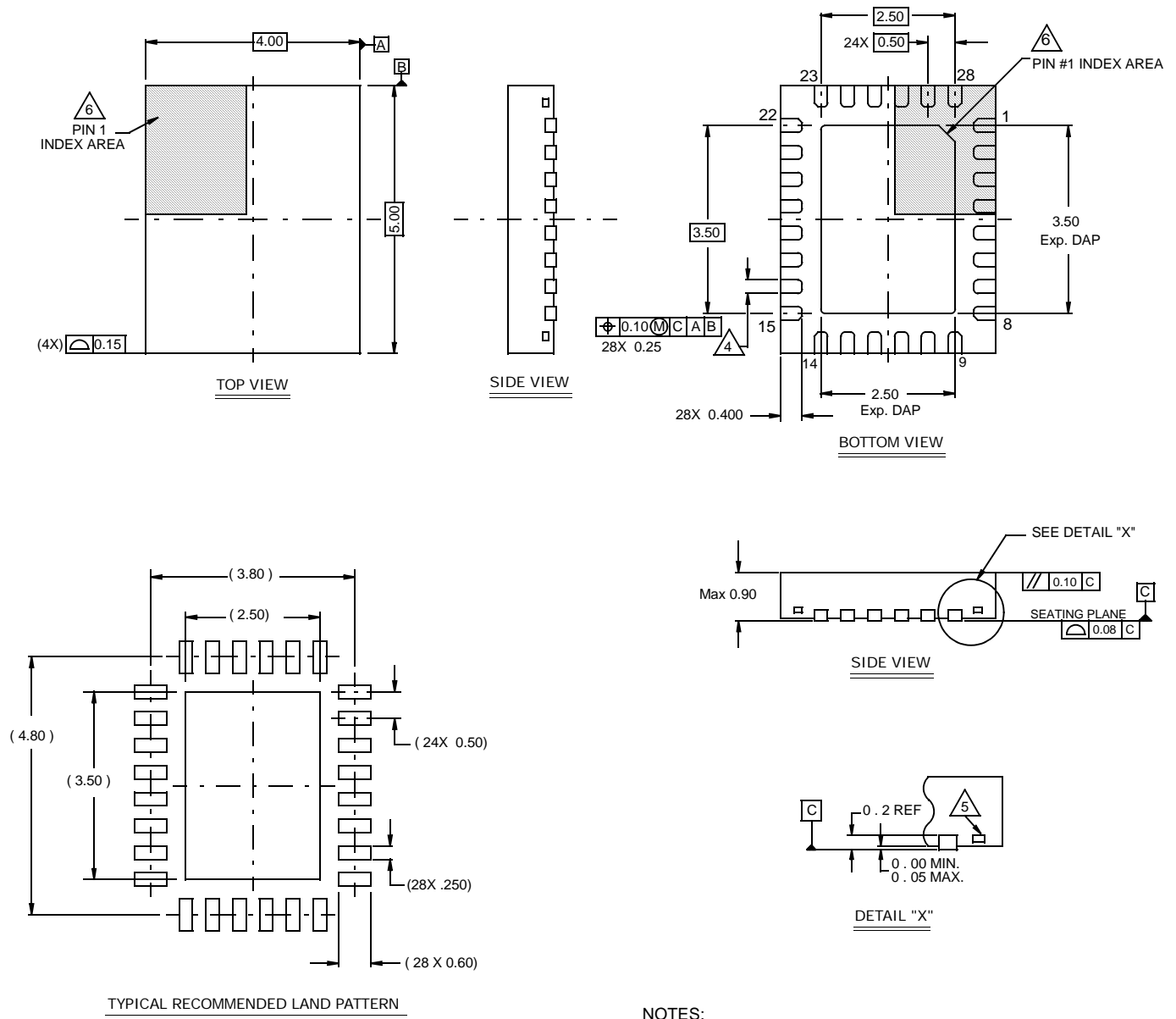

NOTES:

1. Dimensions are in millimeters.
Dimensions in () for Reference Only.
2. Dimensioning and tolerancing conform to AMSE Y14.5m-1994.
3. Unless otherwise specified, tolerance : Decimal ± 0.05
4. Dimension b applies to the metallized terminal and is measured between 0.15mm and 0.30mm from the terminal tip.
5. Tiebar shown (if present) is a non-functional feature.
6. The configuration of the pin #1 identifier is optional, but must be located within the zone indicated. The pin #1 identifier may be either a mold or mark feature.