



UTC4013

Preliminary

CMOS IC

DAUL D-TYPE FLIP-FLOP

DESCRIPTION

The UTC4013 is a dual D-type flip-flop which has two independent circuits and each flip-flop features independent data, set, reset, and clock inputs and outputs. The input level applied to DATA input are transferred to Q and \bar{Q} output by rising edge of the clock pulse. When SET input is "H", and RESET input is "L", outputs become Q="H" and \bar{Q} ="L". When SET input is "L" and RESET input is "H", outputs become Q="L" and \bar{Q} ="H". When both SET input and RESET input are at "H", outputs become Q="H" and \bar{Q} ="H".

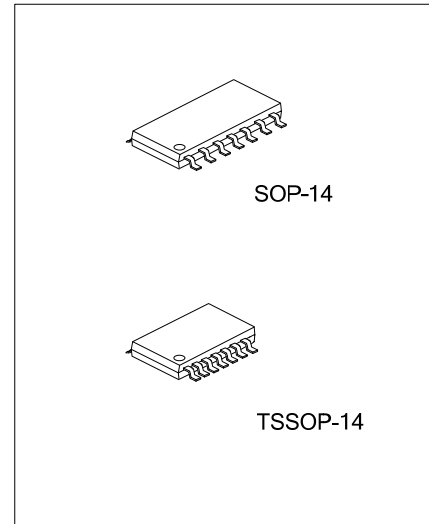

FEATURES

- * Power supply voltage 3V to 18V
- * Maximum Input Current of 1uA at 18V Over Full Package Temperature
- * Maximum quiescent supply current is 4μA

ORDERING INFORMATION

Ordering Number	Package	Packing
UTC4013G-S14-R	SOP-14	Tape Reel
UTC4013G-P14-R	TSSOP-14	Tape Reel

<p>UTC4013G-S14-R</p> <p>(1)Packing Type (2)Package Type (3)Green Package</p>	<p>(1) R: Tape Reel (2) S14: SOP-14, P14: TSSOP-14 (3) G: Halogen Free and Lead Free</p>
---	--

MARKING

SOP-14	TSSOP-14

■ PIN CONFIGURATION

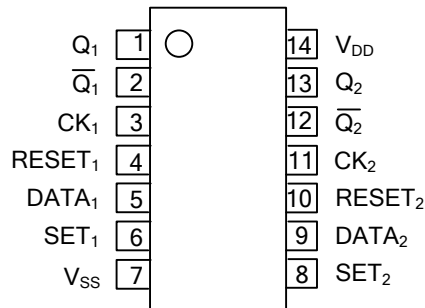

■ FUNCTION TABLE

INPUTS				OUTPUTS	
RESET	SET	DATA	CK*	Q _{n+1}	\bar{Q}_{n+1}
L	H	-	-	H	L
H	L	-	-	L	H
H	H	-	-	H	H
L	L	L	\downarrow	L	H
L	L	H	\downarrow	H	L
L	L	-	\downarrow	No Change	No Change

Note: - : Don't care
 * : Level Change

■ LOGIC DIAGRAM

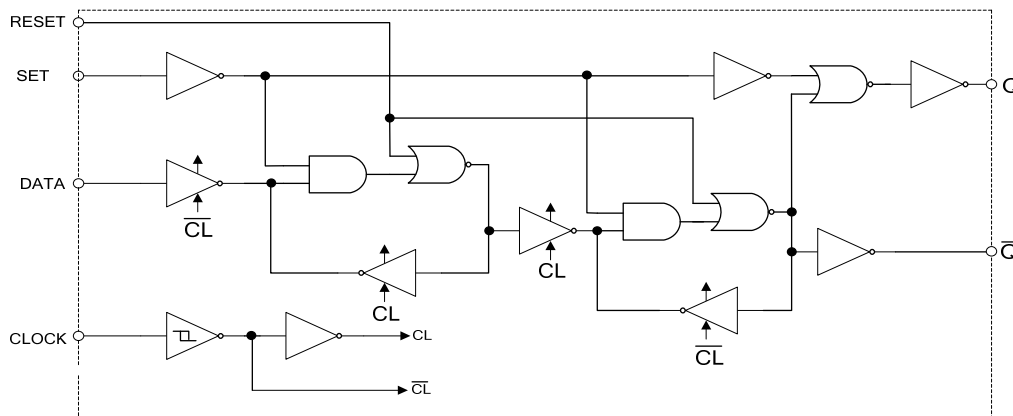

■ BLOCK DIAGRAM

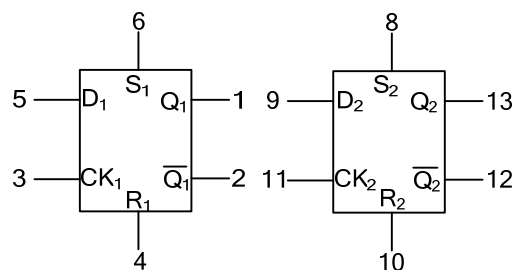

■ ABSOLUTE MAXIMUM RATING ($T_A=25^\circ\text{C}$, unless otherwise specified)

PARAMETER	SYMBOL	RATINGS	UNIT
DC Supply Voltage	V_{DD}	$V_{SS}-0.5$ to $V_{SS}+20$	V
Input Voltage	V_{IN}	$V_{SS}-0.5$ to $V_{DD}+0.5$	V
Output Voltage	V_{OUT}	$V_{SS}-0.5$ to $V_{DD}+0.5$	V
DC Input Current	I_{IN}	± 10	mA
Power Dissipation	P_D	500	mW
Operation Temperature	T_{OPR}	-40 ~ +85	$^\circ\text{C}$
Storage Temperature	T_{STG}	-65 ~ +150	$^\circ\text{C}$

Note: Absolute maximum ratings are those values beyond which the device could be permanently damaged.

Absolute maximum ratings are stress ratings only and functional device operation is not implied.

■ RECOMMENDED OPERATING CONDITIONS ($V_{SS}=0$, $T_A=25^\circ\text{C}$)

PARAMETER	SYMBOL	RATINGS	UNIT
DC Supply Voltage	V_{DD}	3 ~ 18	V
Input Voltage	V_{IN}	0 ~ V_{DD}	V

■ D.C. CHARACTERISTICS ($V_{SS}=0$, $T_A=25^\circ\text{C}$)

PARAMETER		SYMBOL	TEST CONDITIONS	MIN	TYP	MAX	UNIT
Input Voltage	High	V_{IH}	$V_{OUT}=0.5\text{V}, 4.5\text{V}; V_{DD}=5\text{V}, I_{OUT} < 1\mu\text{A}$	3.5	2.75		V
			$V_{OUT}=1.0\text{V}, 9.0\text{V}; V_{DD}=10\text{V}, I_{OUT} < 1\mu\text{A}$	7.0	5.5		
			$V_{OUT}=1.5\text{V}, 13.5\text{V}; V_{DD}=15\text{V}, I_{OUT} < 1\mu\text{A}$	11.0	8.25		
	Low	V_{IL}	$V_{OUT}=0.5\text{V}, 4.5\text{V}; V_{DD}=5\text{V}, I_{OUT} < 1\mu\text{A}$		2.25	1.5	
			$V_{OUT}=1.0\text{V}, 9.0\text{V}; V_{DD}=10\text{V}, I_{OUT} < 1\mu\text{A}$		4.50	3.0	
			$V_{OUT}=1.5\text{V}, 13.5\text{V}; V_{DD}=15\text{V}, I_{OUT} < 1\mu\text{A}$		6.75	4.0	
Output Voltage	High	V_{OH}	$V_{IN}=V_{SS}, V_{DD}; I_{OUT} < 1\mu\text{A}; V_{DD}=5\text{V}$	4.95	5.00		V
			$V_{IN}=V_{SS}, V_{DD}; I_{OUT} < 1\mu\text{A}; V_{DD}=10\text{V}$	9.95	10.00		
			$V_{IN}=V_{SS}, V_{DD}; I_{OUT} < 1\mu\text{A}; V_{DD}=15\text{V}$	14.95	15.00		
	Low	V_{OL}	$V_{IN}=V_{SS}, V_{DD}; I_{OUT} < 1\mu\text{A}; V_{DD}=5\text{V}$		0.00	0.05	
			$V_{IN}=V_{SS}, V_{DD}; I_{OUT} < 1\mu\text{A}; V_{DD}=10\text{V}$		0.00	0.05	
			$V_{IN}=V_{SS}, V_{DD}; I_{OUT} < 1\mu\text{A}; V_{DD}=15\text{V}$		0.00	0.05	
Input Current	High	I_{IH}	$V_{IH}=18\text{V}, V_{DD}=18\text{V}$		10^{-5}	0.1	uA
	Low	I_{IL}	$V_{IL}=0\text{V}, V_{DD}=18\text{V}$		-10^{-5}	-0.1	
Output Current	High	I_{OH}	$V_{OH}=4.6, V_{IN}=V_{SS}, V_{DD}; V_{DD}=5\text{V}$	-0.51	-1.0		mA
			$V_{OH}=2.5, V_{IN}=V_{SS}, V_{DD}; V_{DD}=5\text{V}$	-2.10	-4.0		
			$V_{OH}=9.5, V_{IN}=V_{SS}, V_{DD}; V_{DD}=10\text{V}$	-1.30	-2.2		
	Low	I_{OL}	$V_{OL}=0.4, V_{IN}=V_{SS}, V_{DD}; V_{DD}=5\text{V}$	0.51	1.2		
			$V_{OL}=0.5, V_{IN}=V_{SS}, V_{DD}; V_{DD}=10\text{V}$	1.30	3.2		
			$V_{OL}=1.5, V_{IN}=V_{SS}, V_{DD}; V_{DD}=15\text{V}$	3.40	12.0		
Quiescent Supply Current		I_{DD}	$V_{IN}=V_{SS}, V_{DD}(\text{Note}); V_{DD}=5\text{V}$		0.002	1	uA
			$V_{IN}=V_{SS}, V_{DD}(\text{Note}); V_{DD}=10\text{V}$		0.004	2	
			$V_{IN}=V_{SS}, V_{DD}(\text{Note}); V_{DD}=15\text{V}$		0.008	4	

Note: All valid input combinations.

■ A.C. CHARACTERISTICS ($V_{SS}=0$, $T_A=25^\circ\text{C}$, $C_L=50\text{pF}$)

PARAMETER	SYMBOL	TEST CONDITIONS	MIN	TYP	MAX	UNIT	
Output Transition Time	Low to High	$V_{DD}=5\text{V}$		70	200	ns	
		$V_{DD}=10\text{V}$		35	100		
		$V_{DD}=15\text{V}$		30	80		
	High to Low	$V_{DD}=5\text{V}$		70	200		
		$V_{DD}=10\text{V}$		35	100		
		$V_{DD}=15\text{V}$		30	80		
Propagation Delay Time (CK – Q, \bar{Q})	t_{pLH}	$V_{DD}=5\text{V}$		130	300	ns	
		$V_{DD}=10\text{V}$		65	130		
	t_{pHL}	$V_{DD}=15\text{V}$		50	90		
Propagation Delay Time (SET, RESET – Q, \bar{Q})	t_{pLH}	$V_{DD}=5\text{V}$		110	300		ns
		$V_{DD}=10\text{V}$		50	130		
		$V_{DD}=15\text{V}$		40	90		
	t_{pHL}	$V_{DD}=5\text{V}$		110	300		
		$V_{DD}=10\text{V}$		50	130		
		$V_{DD}=15\text{V}$		40	90		
Max. Clock Frequency	f_{CL}	$V_{DD}=5\text{V}$	3.5	8.0		MHz	
		$V_{DD}=10\text{V}$	8.0	16.0			
		$V_{DD}=15\text{V}$	12.0	20.0			
Max. Clock Input Rise Time	t_{rCL}	$V_{DD}=5\text{V}$	No Limit			μs	
		$V_{DD}=10\text{V}$	No Limit				
		$V_{DD}=15\text{V}$	No Limit				
Max. Clock Input Fall Time	t_{fCL}	$V_{DD}=5\text{V}$	No Limit			μs	
		$V_{DD}=10\text{V}$	No Limit				
		$V_{DD}=15\text{V}$	No Limit				
Min. Pulse Width (SET, RESET)	t_w	$V_{DD}=5\text{V}$		60	180	ns	
		$V_{DD}=10\text{V}$		30	80		
		$V_{DD}=15\text{V}$		25	50		
Min. Clock Pulse Width	t_w	$V_{DD}=5\text{V}$		60	140		
		$V_{DD}=10\text{V}$		30	60		
		$V_{DD}=15\text{V}$		25	40		
Min. Set-up Time (DATA - CK)	t_{su}	$V_{DD}=5\text{V}$			40	ns	
		$V_{DD}=10\text{V}$			20		
		$V_{DD}=15\text{V}$			15		
Min. Hold Time (DATA-CK)	t_H	$V_{DD}=5\text{V}$		20	40		
		$V_{DD}=10\text{V}$		10	20		
		$V_{DD}=15\text{V}$		6	15		
Min. Removal Time (SET, RESET-CK)	t_{rem}	$V_{DD}=5\text{V}$			40		
		$V_{DD}=10\text{V}$			20		
		$V_{DD}=15\text{V}$			15		
Input Capacitance	C_{IN}			5	7.5	pF	

■ PARAMETER MEASUREMENT INFORMATION

1. DATA-CLOCK, Q

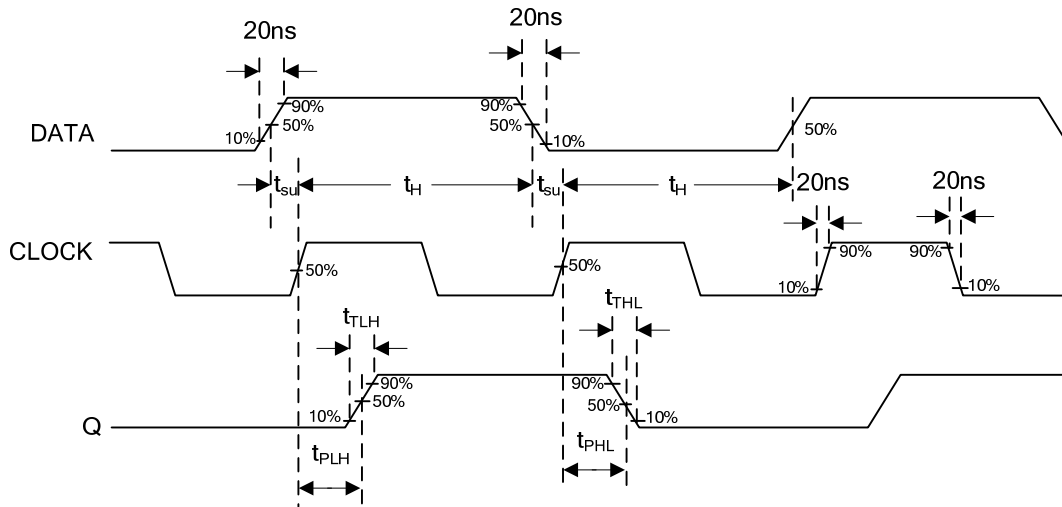

2. SET-RESET, Q

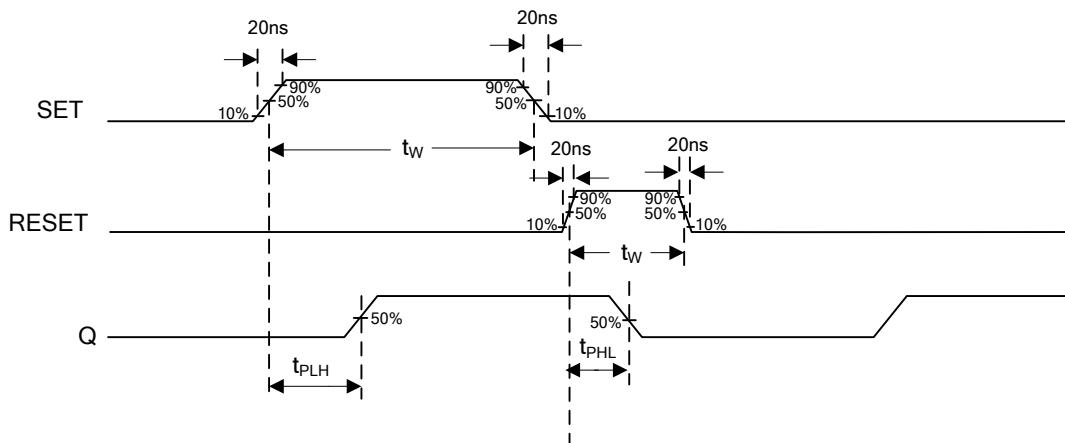

UTC assumes no responsibility for equipment failures that result from using products at values that exceed, even momentarily, rated values (such as maximum ratings, operating condition ranges, or other parameters) listed in products specifications of any and all UTC products described or contained herein. UTC products are not designed for use in life support appliances, devices or systems where malfunction of these products can be reasonably expected to result in personal injury. Reproduction in whole or in part is prohibited without the prior written consent of the copyright owner. The information presented in this document does not form part of any quotation or contract, is believed to be accurate and reliable and may be changed without notice.