



# STEVAL-IFP021V1

## 5 V and 12 V power line protection based on STEF05 and STEF12 electronic fuses

Data brief

### Features

- Input voltages: 5 V and 12 V
- Continuous current: 3.6 A (typ.) each
- Adjustable slew rate for output voltage
- Overvoltage clamp
- Undervoltage lockout
- Programmable short-circuit current limit
- Overload current limit
- Controlled output voltage ramp
- Thermal latch protection
- Fault condition flag
- Enable pin
- RoHS compliant

### Description

The STEVAL-IFP021V1 demonstration board is based on the STEF05 and STEF12 electronic fuses (E-Fuses).

It is designed to help users evaluate the benefit of the complete protection offered by the E-Fuse family and to customize their own application.

The E-Fuse family of hot-swap converters is designed to replace the mechanical fuses on low voltage power lines.

The STEF05 and STEF12 are integrated electronic fuses optimized for monitoring output current and input voltage.

Connected in series to the 5 V/12 V rails, they are capable of protecting the electronic circuitry on the output from overcurrent and overvoltage.

The turn-on time is programmable by means of an external capacitor, allowing control of the inrush current at startup and during hot-swaps.

When an overload condition occurs, the E-Fuse limits the output current to a predefined safe value. If the anomalous overload condition

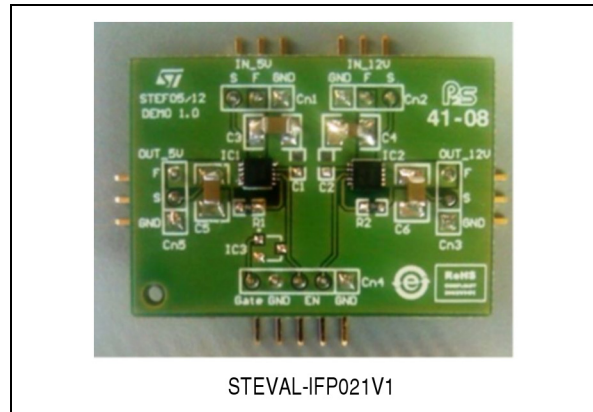

persists, it goes into an open state, disconnecting the load from the power supply.

If a continuous short-circuit is present on the board, when power is re-applied the E-Fuse initially limits the output current to a safe value, and then again goes into an open state.

Both devices are equipped with a thermal protection circuit.

The intervention of the thermal protection is signaled to the board monitoring circuits through a signal on the enable/fault pin that can be connected to other parts belonging to the same family to cause a simultaneous shutdown during failure events.

Unlike mechanical fuses, which must be physically replaced after a single event, E-Fuses do not degrade in their performance after short-circuit/thermal protection interventions and can be reset either by re-cycling the supply voltage or by using the enable pin.

# 1 Circuit schematic

Figure 1. STEVAL-IFP021V1 circuit diagram

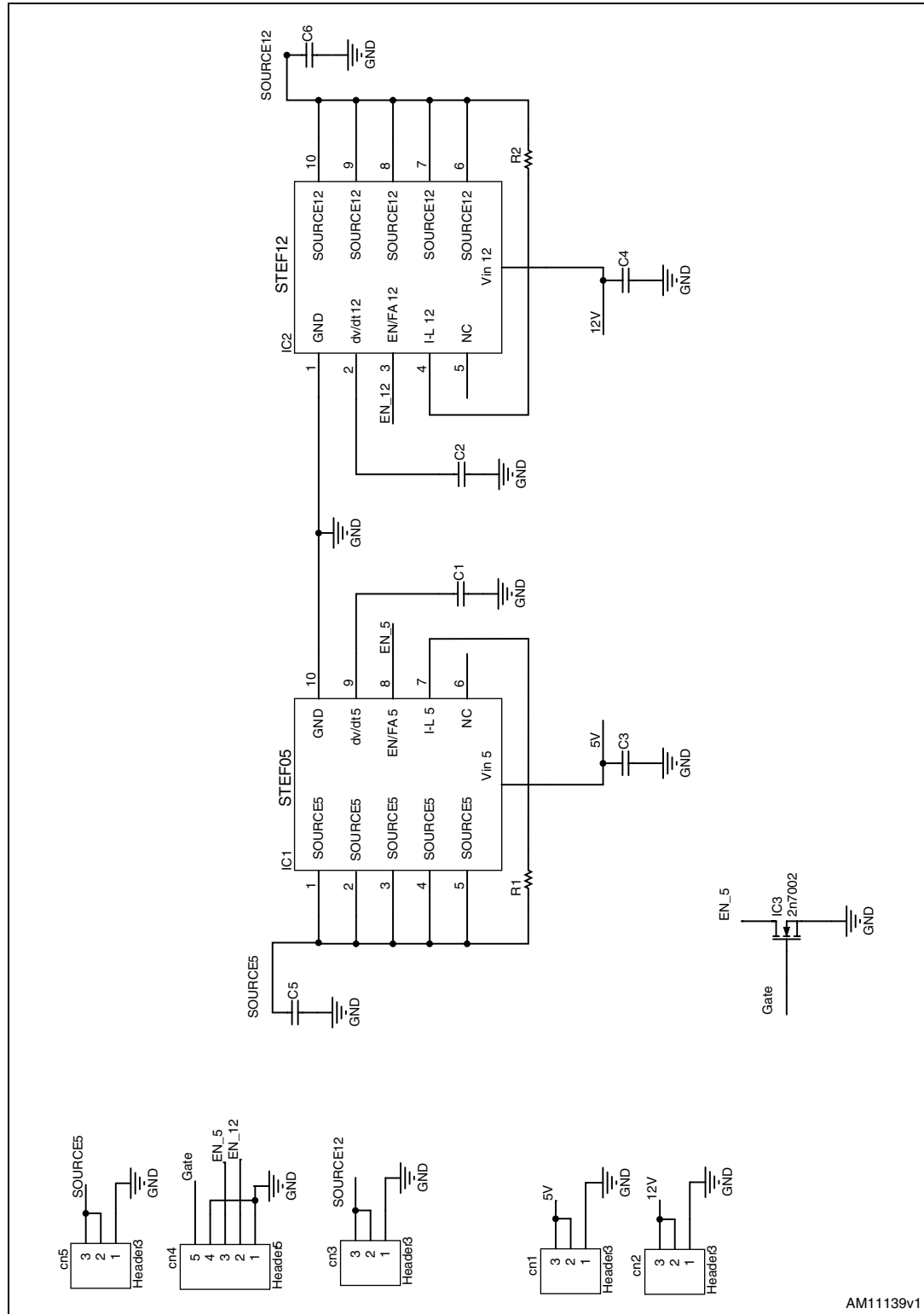

## 2 Revision history

**Table 1. Document revision history**

Date	Revision	Changes
27-Jan-2012	1	Initial release.

**Please Read Carefully:**

Information in this document is provided solely in connection with ST products. STMicroelectronics NV and its subsidiaries ("ST") reserve the right to make changes, corrections, modifications or improvements, to this document, and the products and services described herein at any time, without notice.

All ST products are sold pursuant to ST's terms and conditions of sale.

Purchasers are solely responsible for the choice, selection and use of the ST products and services described herein, and ST assumes no liability whatsoever relating to the choice, selection or use of the ST products and services described herein.

No license, express or implied, by estoppel or otherwise, to any intellectual property rights is granted under this document. If any part of this document refers to any third party products or services it shall not be deemed a license grant by ST for the use of such third party products or services, or any intellectual property contained therein or considered as a warranty covering the use in any manner whatsoever of such third party products or services or any intellectual property contained therein.

**UNLESS OTHERWISE SET FORTH IN ST'S TERMS AND CONDITIONS OF SALE ST DISCLAIMS ANY EXPRESS OR IMPLIED WARRANTY WITH RESPECT TO THE USE AND/OR SALE OF ST PRODUCTS INCLUDING WITHOUT LIMITATION IMPLIED WARRANTIES OF MERCHANTABILITY, FITNESS FOR A PARTICULAR PURPOSE (AND THEIR EQUIVALENTS UNDER THE LAWS OF ANY JURISDICTION), OR INFRINGEMENT OF ANY PATENT, COPYRIGHT OR OTHER INTELLECTUAL PROPERTY RIGHT.**

**UNLESS EXPRESSLY APPROVED IN WRITING BY TWO AUTHORIZED ST REPRESENTATIVES, ST PRODUCTS ARE NOT RECOMMENDED, AUTHORIZED OR WARRANTED FOR USE IN MILITARY, AIR CRAFT, SPACE, LIFE SAVING, OR LIFE SUSTAINING APPLICATIONS, NOR IN PRODUCTS OR SYSTEMS WHERE FAILURE OR MALFUNCTION MAY RESULT IN PERSONAL INJURY, DEATH, OR SEVERE PROPERTY OR ENVIRONMENTAL DAMAGE. ST PRODUCTS WHICH ARE NOT SPECIFIED AS "AUTOMOTIVE GRADE" MAY ONLY BE USED IN AUTOMOTIVE APPLICATIONS AT USER'S OWN RISK.**

Resale of ST products with provisions different from the statements and/or technical features set forth in this document shall immediately void any warranty granted by ST for the ST product or service described herein and shall not create or extend in any manner whatsoever, any liability of ST.

ST and the ST logo are trademarks or registered trademarks of ST in various countries.

Information in this document supersedes and replaces all information previously supplied.

The ST logo is a registered trademark of STMicroelectronics. All other names are the property of their respective owners.

© 2012 STMicroelectronics - All rights reserved

STMicroelectronics group of companies

Australia - Belgium - Brazil - Canada - China - Czech Republic - Finland - France - Germany - Hong Kong - India - Israel - Italy - Japan - Malaysia - Malta - Morocco - Philippines - Singapore - Spain - Sweden - Switzerland - United Kingdom - United States of America

[www.st.com](http://www.st.com)