

## TVJ10B5V0-HF Thru. TVJ10B430-HF

**Reverse Voltage: 5.0 ~ 43 Volts**  
**Peak Pulse Power: 1000 Watts**  
**RoHS Device**  
**Halogen Free**

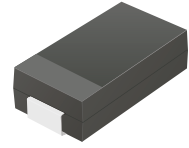

### Features

- Glass passivated chip.
- Low leakage.
- Uni and Bidirectional unit.
- Excellent clamping capability.
- Very fast response time.
- RoHS compliant.

### Mechanical Data

- Case: Molded plastic
- Epoxy: UL 94V-0 rate flame retardant.
- Lead: Solderable per MIL-STD-750, method 2026
- Polarity: Color band denotes cathode end except Bipolar.
- Approx. weight: 0.108 grams

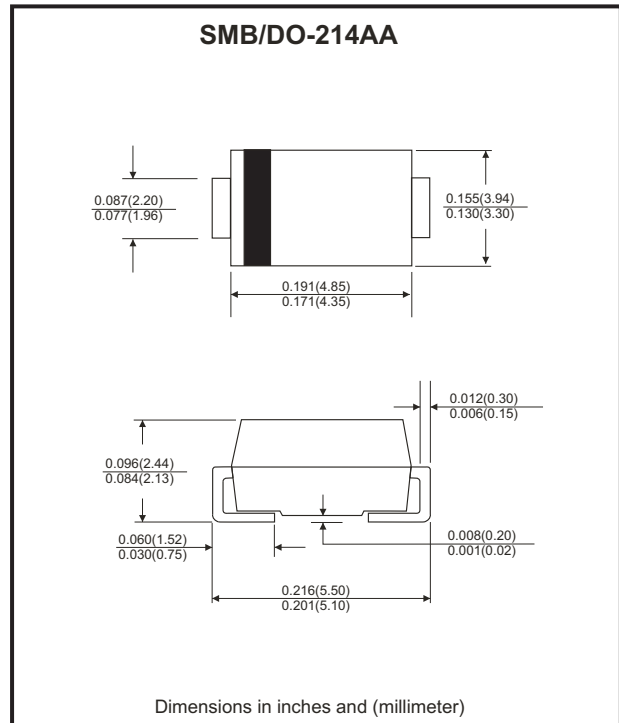

### Maximum Ratings and Electrical Characteristics

Rating at 25°C ambient temperature unless otherwise specified.  
 Single phase, half wave, 60Hz, resistive or inductive load.  
 For capacitive load, derate current by 20%.

Parameter	Symbol	Value	Units
Peak power dissipation with a 10/1000µs waveform (Note 1)	P <sub>PP</sub>	1000	W
Peak pulse current with a 10/1000µs waveform (Note 1)	I <sub>PP</sub>	See Next Table	A
Power dissipation on infinite heatsink at T <sub>L</sub> =75°C	P <sub>D</sub>	5.0	W
Peak forward surge current, 8.3ms single half sine-wave uni-directional only (Note 2)	I <sub>FSM</sub>	100	A
Maximum instantaneous forward voltage at 25A for uni-directional only (Note 3)	V <sub>F</sub>	3.5/5.0	V
Operation junction temperature	T <sub>J</sub>	-55 to +150	°C
Storage temperature range	T <sub>STG</sub>	-55 to +150	°C

Note:

1. Non-repetitive current pulse, per Fig.5 and derated above TA=25°C per Fig.1
2. Measured on 8.3 ms single half sine-wave or equivalent square wave, duty cycle = 4 pulse per minute maximum.
3. V<sub>F</sub><3.5V for devices of V<sub>BR</sub> <50V.

Company reserves the right to improve product design , functions and reliability without notice.

REV: A

## Rating and Characteristics Curves (TVJ10B5V0-HF Thru. TVJ10B430-HF)

Fig.1 - Pulse Derating Curve

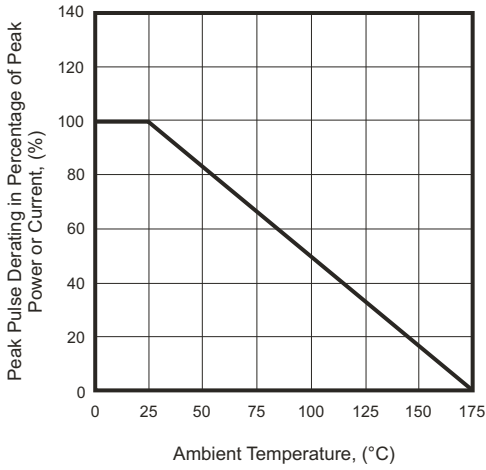

Fig.2 - Maximum Non-Repetitive Surge Current

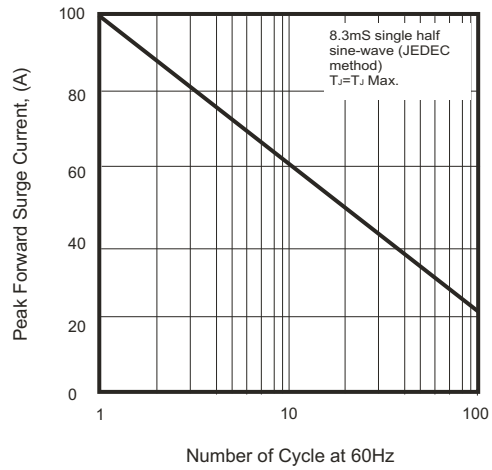

Fig.3 - Steady State Power Derating Curve

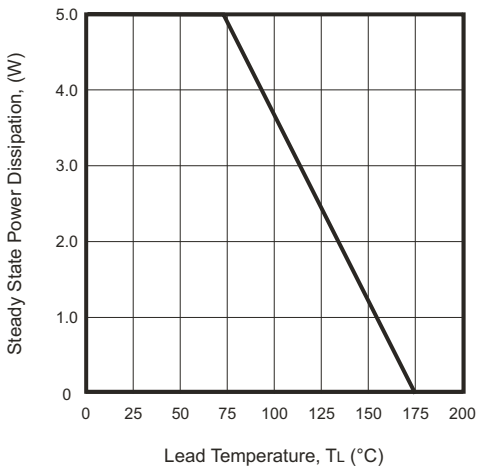

Fig.4 - Peak Pulse Power Rating Curve

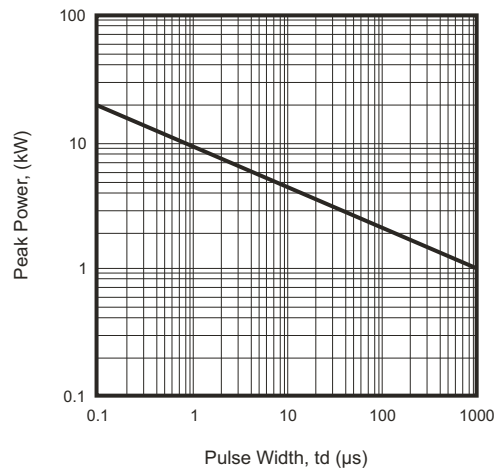

Fig.5 - Pulse Waveform

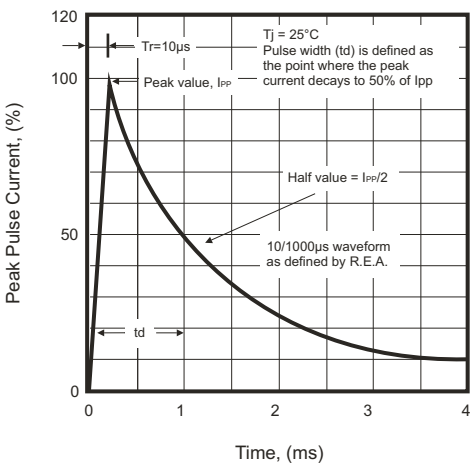
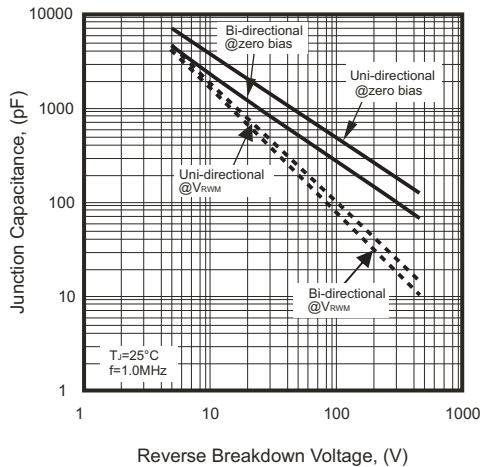

Fig.6 - Typical Junction Capacitance



# SMD Transient Voltage Suppressor

## Electrical Characteristics (TVJ10B5V0-HF Thru. TVJ10B430-HF)

Part No.	Breakdown voltage V <sub>BR</sub> @ I <sub>T</sub>			Maximum Reverse Leakage @V <sub>RWM</sub> I <sub>R</sub> (uA)	Working Peak Reverse Voltage V <sub>RWM</sub> (V)	Maximum Reverse Surge Current I <sub>PP</sub> (A)	Maximum Clamping Voltage @I <sub>PP</sub> V <sub>c</sub> (V)	Device Marking Code	
	Min. (V)	Max. (V)	I <sub>T</sub> (mA)					UNI	BI
TVJ10B5V0J(B)-HF	6.40	7.00	10	800	5.0	108.70	9.2	AKE	AAE
TVJ10B6V0J(B)-HF	6.67	7.37	10	800	6.0	97.09	10.3	AKG	AAG
TVJ10B6V5J(B)-HF	7.22	7.98	10	500	6.5	89.29	11.2	AKK	AAK
TVJ10B7V0J(B)-HF	7.78	8.60	10	200	7.0	83.33	12.0	AKM	AAM
TVJ10B7V5J(B)-HF	8.33	9.21	1	100	7.5	77.52	12.9	AKP	AAP
TVJ10B8V0J(B)-HF	8.89	9.83	1	50	8.0	73.53	13.6	AKR	AAR
TVJ10B8V5J(B)-HF	9.44	10.40	1	10	8.5	69.44	14.4	AKT	AAT
TVJ10B9V0J(B)-HF	10.00	11.10	1	5.0	9.0	64.94	15.4	AKV	AAV
TVJ10B100J(B)-HF	11.10	12.30	1	5.0	10.0	58.82	17.0	AKX	AAX
TVJ10B110J(B)-HF	12.20	13.50	1	5.0	11.0	54.95	18.2	AKZ	AAZ
TVJ10B120J(B)-HF	13.30	14.70	1	5.0	12.0	50.25	19.9	ALE	ABE
TVJ10B130J(B)-HF	14.40	15.90	1	1.0	13.0	46.51	21.5	ALG	ABG
TVJ10B140J(B)-HF	15.60	17.20	1	1.0	14.0	43.10	23.2	ALK	ABK
TVJ10B150J(B)-HF	16.70	18.50	1	1.0	15.0	40.98	24.4	ALM	ABM
TVJ10B160J(B)-HF	17.80	19.70	1	1.0	16.0	38.46	26.0	ALP	ABP
TVJ10B170J(B)-HF	18.90	20.90	1	1.0	17.0	36.23	27.6	ALR	ABR
TVJ10B180J(B)-HF	20.00	22.10	1	1.0	18.0	34.25	29.2	ALT	ABT
TVJ10B190J(B)-HF	21.10	23.30	1	1.0	19.0	32.49	30.8	ALB	ABB
TVJ10B200J(B)-HF	22.20	24.50	1	1.0	20.0	30.86	32.4	ALV	ABV
TVJ10B220J(B)-HF	24.40	26.90	1	1.0	22.0	28.17	35.5	ALX	ABX
TVJ10B240J(B)-HF	26.70	29.50	1	1.0	24.0	25.71	38.9	ALZ	ABZ
TVJ10B260J(B)-HF	28.90	31.90	1	1.0	26.0	23.75	42.1	AME	ACE
TVJ10B280J(B)-HF	31.10	34.40	1	1.0	28.0	22.03	45.4	AMG	ACG
TVJ10B300J(B)-HF	33.30	36.80	1	1.0	30.0	20.66	48.4	AMK	ACK
TVJ10B330J(B)-HF	36.70	40.60	1	1.0	33.0	18.76	53.3	AMM	ACM
TVJ10B360J(B)-HF	40.00	44.20	1	1.0	36.0	17.21	58.1	AMP	ACP
TVJ10B400J(B)-HF	44.40	49.10	1	1.0	40.0	15.50	64.5	AMR	ACR
TVJ10B430J(B)-HF	47.80	52.80	1	1.0	43.0	14.41	69.4	AMT	ACT

Note:

- 1) Suffix J denotes 5% tolerance devices.
- 2) Suffix B after part number to specify bi-directional devices.
- 3) For Bi-Directional devices having V<sub>R</sub> of 10 volts and under, the I<sub>R</sub> limit is double.

## Reel Taping Specification

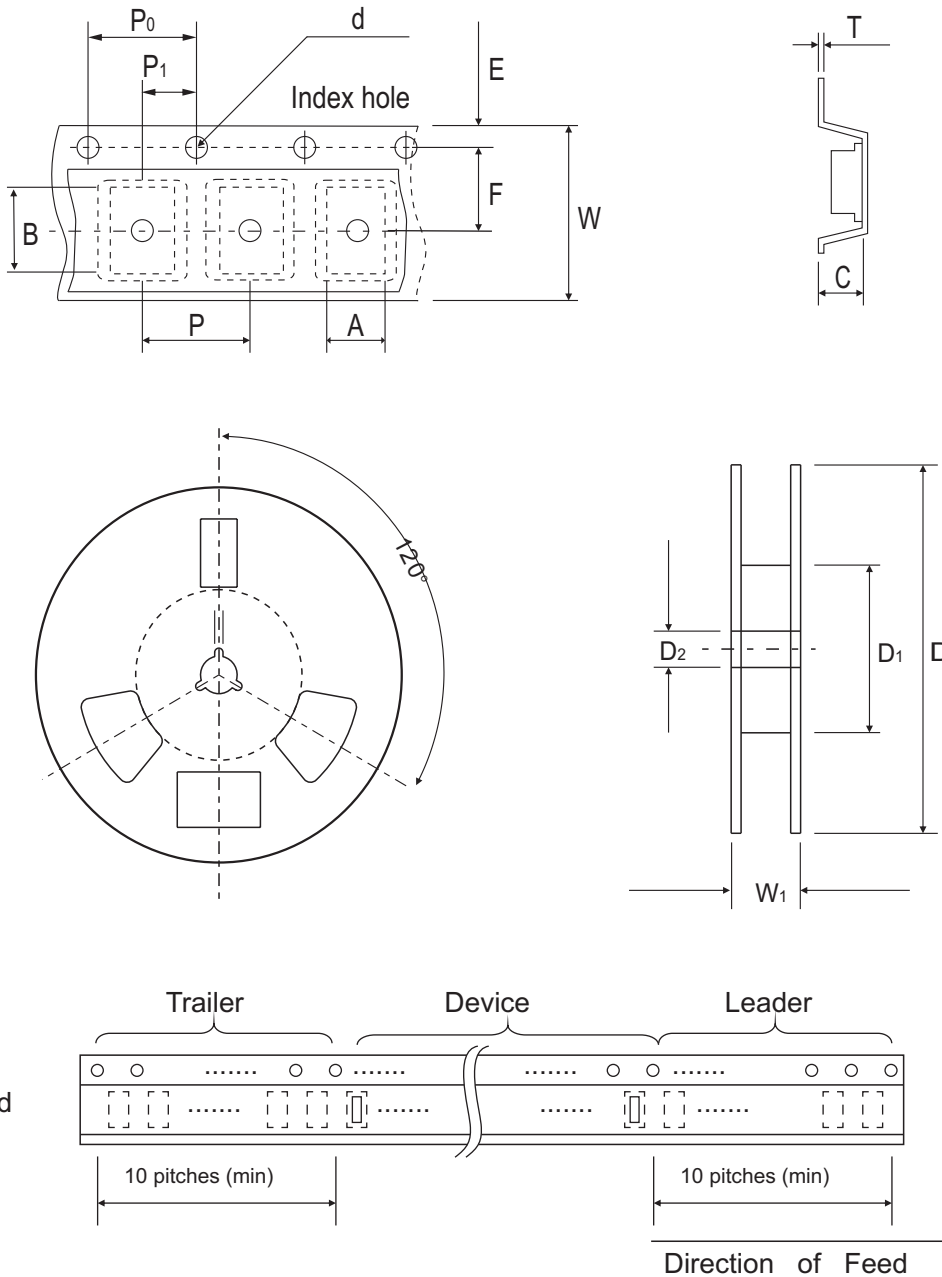

DO-214AA (SMB)	SYMBOL	A	B	C	d	D	D1	D2
	(mm)	$3.67 \pm 0.10$	$5.69 \pm 0.10$	4.50 (max)	$1.55 \pm 0.10$	330.00	50.00 (min)	$13.00 \pm 0.20$
	(inch)	$0.144 \pm 0.004$	$0.224 \pm 0.004$	0.177 (max)	$0.061 \pm 0.004$	13.000	1.969 (min)	$0.512 \pm 0.008$

DO-214AA (SMB)	SYMBOL	E	F	P	P0	P1	W	W1
	(mm)	$1.75 \pm 0.10$	$5.50 \pm 0.05$	$8.00 \pm 0.10$	$4.00 \pm 0.10$	$2.00 \pm 0.05$	$12.00 \pm 0.30$	18.40 (max)
	(inch)	$0.069 \pm 0.004$	$0.217 \pm 0.002$	$0.315 \pm 0.004$	$0.157 \pm 0.004$	$0.079 \pm 0.002$	$0.472 \pm 0.012$	0.724 (max)

Company reserves the right to improve product design, functions and reliability without notice.

REV: A

## Marking Code

Part Number	Marking Code
TVJ10BXXX-HF	See Page.3

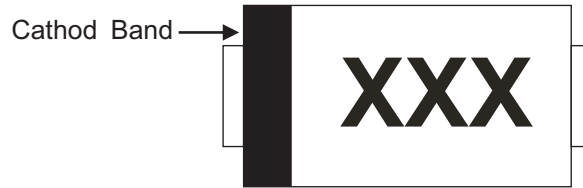

XXX = Marking code (see Page.3)

## Suggested PAD Layout

SIZE	DO-214AA(SMB)	
	(mm)	(inch)
A	5.60	0.220
B	2.16 MAX	0.085 MAX
C	1.52 MIN	0.060 MIN
D	2.18 MIN	0.086 MIN

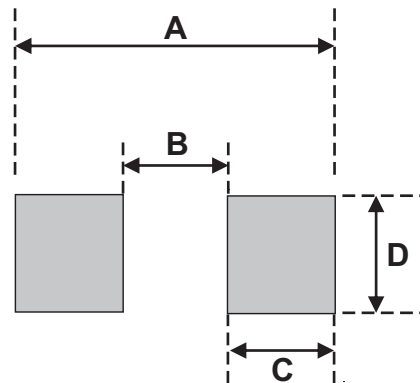

## Standard Packaging

Case Type	REEL PACK	
	REEL ( pcs )	Reel Size (inch)
DO-214AA (SMB)	3,000	13