

TLP627X
TLP627



ISOCOM
COMPONENTS



**HIGH VOLTAGE DARLINGTON
OUTPUT OPTICALLY COUPLED
ISOLATOR**

APPROVALS

- UL recognised, File No. E91231

'X' SPECIFICATION APPROVALS

- VDE 0884 in 3 available lead forms :-
- STD
- G form
- SMD approved to CECC 00802

DESCRIPTION

The TLP627 is an optically coupled isolator consisting of infrared light emitting diode and a high voltage NPN silicon photo darlington which has an integral base-emitter resistor to optimise switching speed and elevated temperature characteristics in a standard 4 pin dual in line plastic package.

FEATURES

- Options :-
10mm lead spread - add G after part no.
Surface mount - add SM after part no.
Tape&reel - add SMT&R after part no.
- High Isolation Voltage (5.3kV_{RMS}, 7.5kV_{PK})
- High Current Transfer Ratio (1000% min.)
- High BV_{CEO} (300V min.)
- Low input current 1mA I_F

APPLICATIONS

- Modems
- Copiers, facsimiles
- Numerical control machines
- Signal transmission between systems of different potentials and impedances

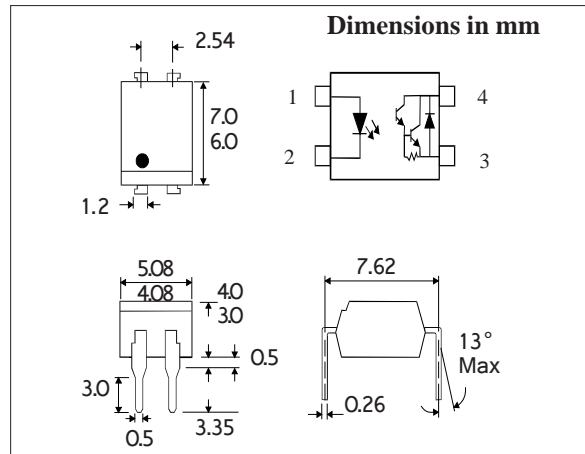

**ABSOLUTE MAXIMUM RATINGS
(25°C unless otherwise specified)**

Storage Temperature _____ -55°C to +125°C
Operating Temperature _____ -30°C to +100°C
Lead Soldering Temperature
(1/16 inch (1.6mm) from case for 10 secs) 260°C

INPUT DIODE

Forward Current _____ 50mA
Reverse Voltage _____ 6V
Power Dissipation _____ 70mW

OUTPUT TRANSISTOR

Collector-emitter Voltage BV_{CEO} _____ 300V
Collector Current I_C _____ 150mA
Power Dissipation _____ 150mW

POWER DISSIPATION

Total Power Dissipation _____ 200mW

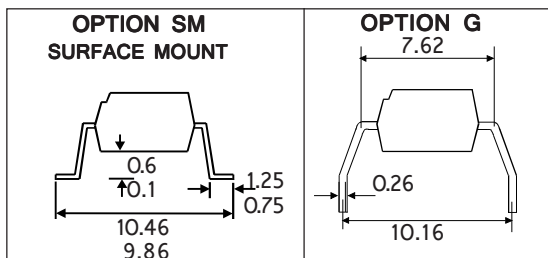

ISOCOM COMPONENTS LTD
Unit 25B, Park View Road West,
Park View Industrial Estate, Brenda Road
Hartlepool, TS25 1YD England Tel: (01429)863609
Fax : (01429) 863581 e-mail sales@isocom.co.uk
<http://www.isocom.com>

ELECTRICAL CHARACTERISTICS ($T_A = 25^\circ\text{C}$ Unless otherwise noted)

PARAMETER		MIN	TYP	MAX	UNITS	TEST CONDITION
Input	Forward Voltage (V_F)	1.0	1.15	1.3	V	$I_F = 10\text{mA}$
	Reverse Current (I_R)			10	μA	$V_R = 4\text{V}$
Output	Collector-emitter Breakdown (BV_{CEO})	300			V	$I_C = 0.1\text{mA}$
	Emitter-collector Breakdown (BV_{ECO})	0.3			V	$I_E = 0.1\text{mA}$
	Collector-emitter Dark Current (I_{CEO})		10	200	nA	$V_{CE} = 200\text{V}$
Coupled	Current Transfer Ratio (CTR)	1000	4000		%	$1\text{mA } I_F, 1\text{V } V_{CE}$
	Saturated CTR (CTR_{SAT})	500			%	$10\text{mA } I_F, 1\text{V } V_{CE}$
	Collector-emitter Saturation Voltage $V_{CE(SAT)}$			1.2	V	$10\text{mA } I_F, 100\text{mA } I_C$
	Collector-emitter Saturation Voltage $V_{CE(SAT)}$			1.0	V	$1\text{mA } I_F, 10\text{mA } I_C$
	Input to Output Isolation Voltage V_{ISO}	5300			V_{RMS}	See note 1
		7500			V_{PK}	See note 1
	Input-output Isolation Resistance R_{ISO}	5×10^{10}			Ω	$V_{IO} = 500\text{V}$ (note 1)
	Input-output Capacitance C_f			1	pF	$V = 0, f = 1\text{MHz}$
Output Rise Time	tr		40	μs	$V_{CC} = 10\text{V}, I_C = 10\text{mA}, R_L = 100\Omega$	
Output Fall Time	tf		15	μs		

Note 1 Measured with input leads shorted together and output leads shorted together.

Note 2 Special Selections are available on request. Please consult the factory.

FIGURE 1

