

# PA93

## FEATURES

- HIGH VOLTAGE — 400V ( $\pm 200V$ )
- LOW QUIESCENT CURRENT — 10mA
- HIGH OUTPUT CURRENT — 8A
- PROGRAMMABLE CURRENT LIMIT

## APPLICATIONS

- PIEZOELECTRIC POSITIONING
- HIGH VOLTAGE INSTRUMENTATION
- ELECTROSTATIC TRANSDUCERS
- PROGRAMMABLE POWER SUPPLIES UP TO 390V

## DESCRIPTION

The PA93 is a high voltage, low quiescent current MOSFET operational amplifier designed as a low cost solution for driving continuous output currents up to 8A and pulse currents up to 14A. The safe operating area (SOA) has no second breakdown limitations and can be observed for all type loads by choosing an appropriate current limiting resistor. The MOSFET output stage is biased AB for linear operation. External compensation provides flexibility in choosing bandwidth and slew rate for the application. APEX's Power SIP package uses a minimum of board space allowing for high density circuit boards.



## TYPICAL APPLICATION

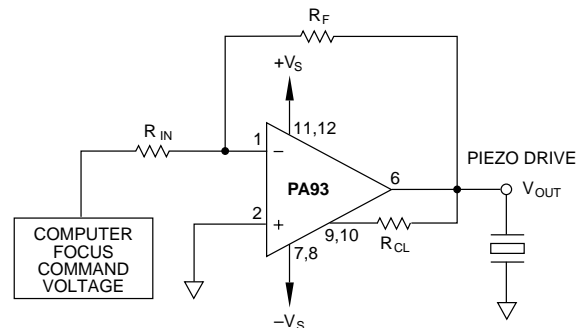

### LOW POWER, PIEZOELECTRIC POSITIONING

Piezo positioning may be applied to the focusing of segmented mirror systems. The composite mirror may be composed of hundreds of elements, each requiring focusing under computer control. In such complex systems the PA93 reduces the costs of power supplies and cooling with its advantages of low cost and low quiescent power consumption while increasing circuit density with the SIP package.

## PHASE COMPENSATION

GAIN	$C_C^*$	$R_C$
$\geq 1$	220pF	100 $\Omega$
$\geq 2$	100pF	100 $\Omega$
$\geq 4$	47pF	0 $\Omega$
$\geq 17$	10pF	0 $\Omega$

\* $C_C$  Never to be < 10pF.  $C_C$  To be rated for the full supply voltage +V to -V<sub>S</sub>. Use ceramic NPO (COG) type.

## EQUIVALENT SCHEMATIC

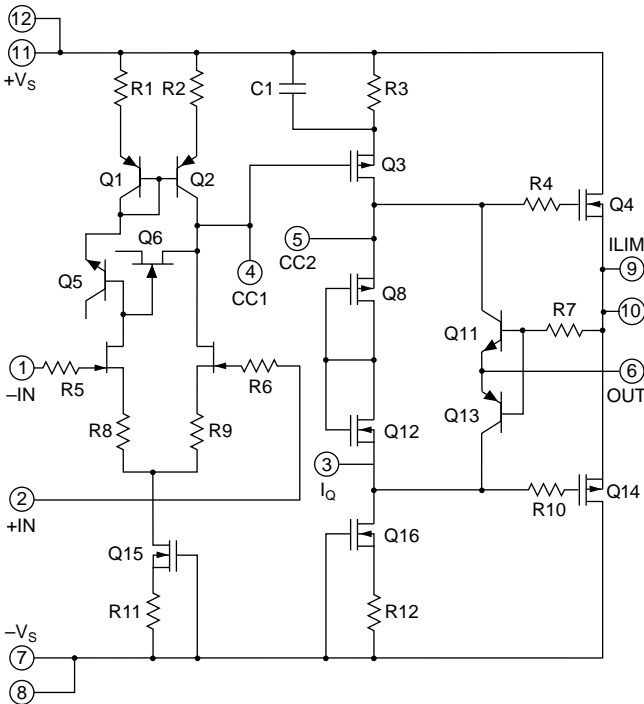

## EXTERNAL CONNECTIONS

Package: SIP03

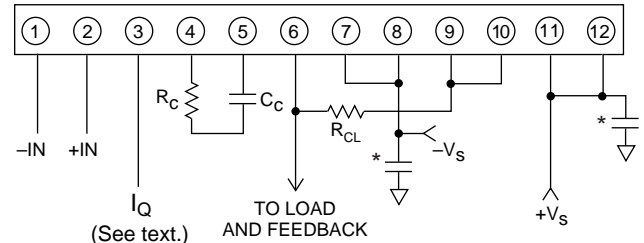

\* Bypassing required.

# PA93

## ABSOLUTE MAXIMUM RATINGS SPECIFICATIONS

### ABSOLUTE MAXIMUM RATINGS

SUPPLY VOLTAGE, $+V_S$ to $-V_S$	400V
OUTPUT CURRENT, source, sink, peak	14A, within SOA
POWER DISSIPATION, continuous @ $T_C = 25^\circ\text{C}$	125W
INPUT VOLTAGE, differential	$\pm 20\text{V}$
INPUT VOLTAGE, common mode	$\pm V_S$
TEMPERATURE, pin solder - 10s max	$220^\circ\text{C}$
TEMPERATURE, junction <sup>2</sup>	$150^\circ\text{C}$
TEMPERATURE, storage	$-65$ to $+150^\circ\text{C}$
OPERATING TEMPERATURE RANGE, case	$-55$ to $+125^\circ\text{C}$

### SPECIFICATIONS

PARAMETER	TEST CONDITIONS <sup>1</sup>	MIN	TYP	MAX	UNITS
<b>INPUT</b>					
OFFSET VOLTAGE, initial			2	10	mV
OFFSET VOLTAGE, vs. temperature	Full temperature range		15	50	$\mu\text{V}/^\circ\text{C}$
OFFSET VOLTAGE, vs. supply			10	25	$\mu\text{V}/\text{V}$
OFFSET VOLTAGE, vs. time			75		$\mu\text{V}/\text{kh}$
BIAS CURRENT, initial			200	2000	pA
BIAS CURRENT, vs. supply			4		pA/V
OFFSET CURRENT, initial			50	500	pA
INPUT IMPEDANCE, DC			$10^{11}$		$\Omega$
INPUT CAPACITANCE			4		pF
COMMON MODE VOLTAGE RANGE <sup>3</sup>		$\pm V_S \mp 15$			V
COMMON MODE REJECTION, DC	$V_{CM} = \pm 90\text{V}$	80	98		dB
NOISE	100kHz BW, $R_S = 1\text{K}\Omega$ , $C_C = 10\text{pF}$		1		$\mu\text{V}_{rms}$
<b>GAIN</b>					
OPEN LOOP, @ 15Hz	$R_L = 2\text{K}\Omega$ , $C_C = 10\text{pF}$	94	111		dB
GAIN BANDWIDTH PRODUCT at 1MHz	$R_L = 2\text{K}\Omega$ , $C_C = 10\text{pF}$		12		MHz
POWER BANDWIDTH	$R_L = 2\text{K}\Omega$ , $C_C = 10\text{pF}$		30		kHz
PHASE MARGIN	Full temperature range		60		$^\circ$
<b>OUTPUT</b>					
VOLTAGE SWING <sup>3</sup>	$I_O = 8\text{A}$	$\pm V_S \mp 12$	$\pm V_S \mp 10$		V
CURRENT, continuous		8			A
SLEW RATE, $A_V = 100$	$C_C = 10\text{pF}$		50		$\text{V}/\mu\text{s}$
CAPACITIVE LOAD, $A_V = +1$	Full temperature range	1			nf
SETTLING TIME to .1%	$C_C = 10\text{pF}$ , 2V step		1		$\mu\text{s}$
RESISTANCE, no load			10		$\Omega$
<b>POWER SUPPLY</b>					
VOLTAGE <sup>5</sup>	See note 5	$\pm 40$	$\pm 150$	$\pm 200$	V
CURRENT, quiescent,			10	14	mA
<b>THERMAL</b>					
RESISTANCE, AC, junction to case <sup>4</sup>	Full temperature range, $F > 60\text{Hz}$			.7	$^\circ\text{C}/\text{W}$
RESISTANCE, DC, junction to case	Full temperature range, $F < 60\text{Hz}$			1	$^\circ\text{C}/\text{W}$
RESISTANCE, junction to air	Full temperature range		30		$^\circ\text{C}/\text{W}$
TEMPERATURE RANGE, case	Meets full range specifications	-25		+85	$^\circ\text{C}$

- NOTES: 1. Unless otherwise noted:  $T_C = 25^\circ\text{C}$ , DC input specifications are  $\pm$  value given. Power supply voltage is typical rating.  $R_C = 100$   
 $C_C = 220\text{pF}$ .  
 2. Long term operation at the maximum junction temperature will result in reduced product life. Derate internal power dissipation to achieve high MTTF.  
 3.  $+V_S$  and  $-V_S$  denote the positive and negative power supply rail respectively.  
 4. Rating applies if the output current alternates between both output transistors at a rate faster than 60Hz.  
 5. Derate max supply rating .625 V/ $^\circ\text{C}$  below  $25^\circ\text{C}$  case. No derating needed above  $25^\circ\text{C}$  case.

### CAUTION

The PA93 is constructed from MOSFET transistors. ESD handling procedures must be observed.

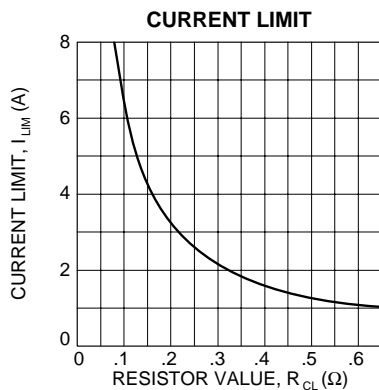
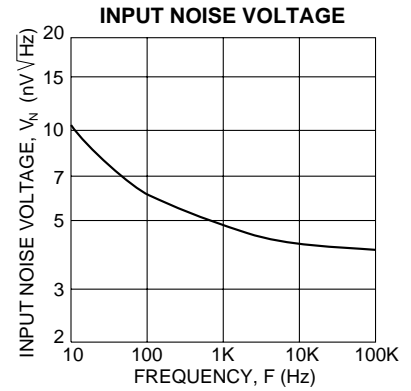
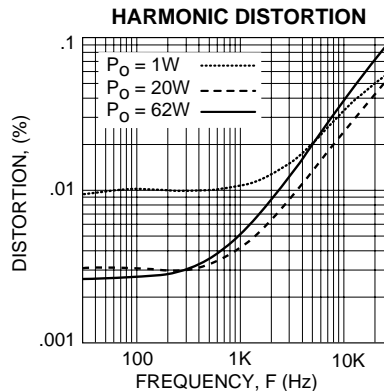
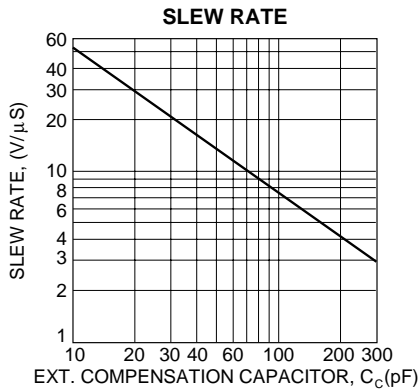
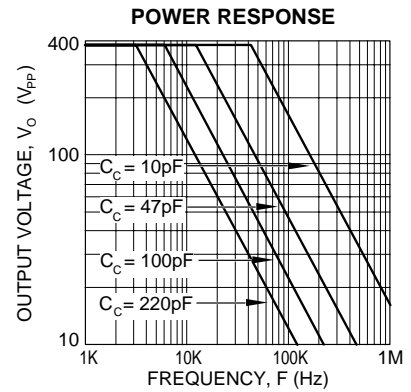
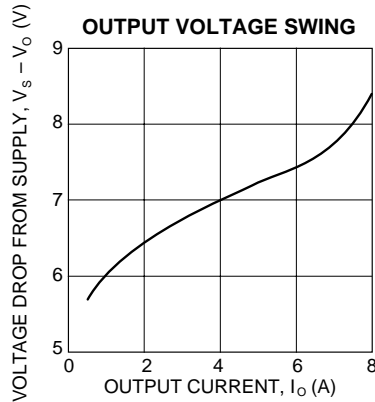
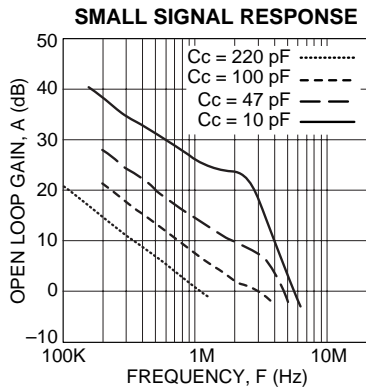
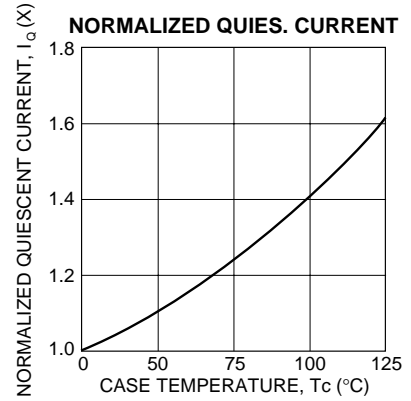
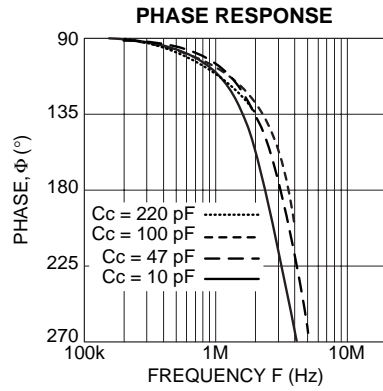
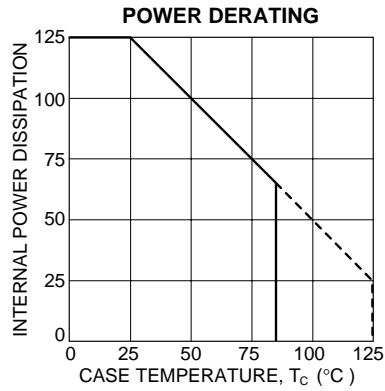

### GENERAL

Please read the "General Operating Considerations" section, which covers stability, supplies, heatsinking, mounting, current limit, SOA interpretation, and specification interpretation. Additional information can be found in the application notes. For information on the package outline, heatsinks, and mounting hardware, consult the "Accessory and Package Mechanical Data" section of the handbook.

### CURRENT LIMIT

For proper operation, the current limit resistor ( $R_{CL}$ ) must be connected as shown in the external connection diagram. For optimum reliability the resistor value should be set as high as possible. The value is calculated as follows; with the maximum practical value of 16 ohms.

$$R_{CL} = \frac{.65}{I_{LIM}}$$

### SAFE OPERATING AREA (SOA)

The MOSFET output stage of this power operational amplifier has two distinct limitations:

1. The current handling capability of the MOSFET geometry and the wire bonds.
2. The junction temperature of the output MOSFETs.

NOTE: The output stage is protected against transient flyback. However, for protection against sustained, high energy flyback, external fast-recovery diodes should be used.

### SAFE OPERATING CURVES

The safe operating area curves define the maximum additional internal power dissipation the amplifier can tolerate when it produces the necessary output to drive an external load.

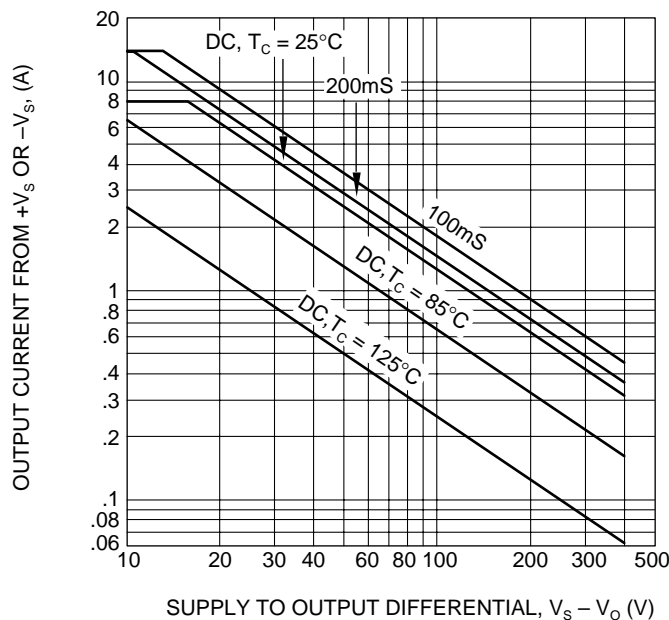

### INPUT PROTECTION

Although the PA93 can withstand differential voltages up to  $\pm 20V$ , additional external protection is recommended. Low leakage, low capacitance JFETs connected as diodes are recommended (e.g. 2N4416, Q1-Q4 in Figure 2). The differential input voltage will be clamped to  $\pm 1.4V$ . This is sufficient overdrive to produce maximum power bandwidth.

### POWER SUPPLY PROTECTION

Unidirectional zener diode transient suppressors are recommended as protection on the supply pins. See Figure 2. The zeners clamp transients to voltages within the power supply rating and also clamp power supply reversals to ground. Whether the zeners are used or not, the system power supply should be evaluated for transient performance including power-on overshoot and power-off polarity reversals as well as line regulation.

Conditions which can cause open circuits or polarity reversals on either power supply rail should be avoided or protected against. Reversals or opens on the negative supply rail is known to induce input stage failure. Unidirectional transzors prevent this, and it is desirable that they be both electrically and physically as close to the amplifier as possible.

### STABILITY

The PA93 is externally compensated and performance can be tailored to the application. Use the graphs of small signal response and power response as a guide. The compensation capacitor  $C_C$  must be rated at 500V working voltage. An NPO capacitor is recommended. The compensation network  $C_C R_C$  must be mounted closely to the amplifier pins 4 and 5 to avoid spurious oscillation.

### QUIESCENT CURRENT REDUCTION

When pin 3 ( $I_Q$ ) is shorted to pin 5 (CC2) the AB biasing of the output stage is disabled. This lowers quiescent power but also raises distortion since the output stage is then class C biased. The output stage bias current is nominally set at 1mA. Pin 3 may be left open if not used.

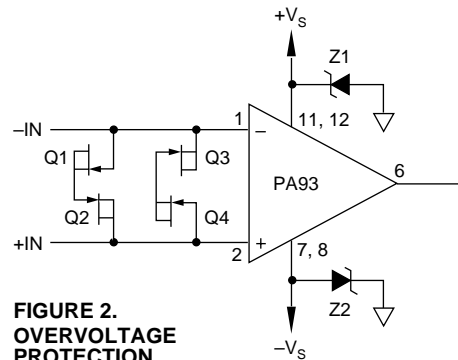

**FIGURE 2.**  
OVERVOLTAGE PROTECTION