

General Description

The MAX14667 is a dual USB charger adapter emulator with automatic host charger identification circuitry for USB dedicated chargers.

The device allows USB wall adapters, travel chargers, and other dedicated chargers to identify themselves as a USB dedicated charger to USB devices, an Apple charger to Apple products, and a Samsung Galaxy Tablet dedicated charger port to Samsung Galaxy Tablet devices.

The device features a control input that allows for charger mode selection. The MAX14667 supports USB Battery Charger (BC) revision 1.2 specification compliant devices, including all major brand USB devices from Samsung, Nokia, Blackberry, LG, Apple devices, and Samsung Galaxy devices in autodetection 1A or autodetection 2A modes.

The MAX14667 is available in an 8-pin (2.9mm x 1.6mm) SOT23 package, and is specified over the -40°C to +85°C extended temperature range.

Applications

- USB Wall Charger and Travel Adapter
- USB Car Charger and Cigarette Lighter Adapter
- Universal Charger Including iPod®/iPad®/iPhone®

Typical Operating Circuit

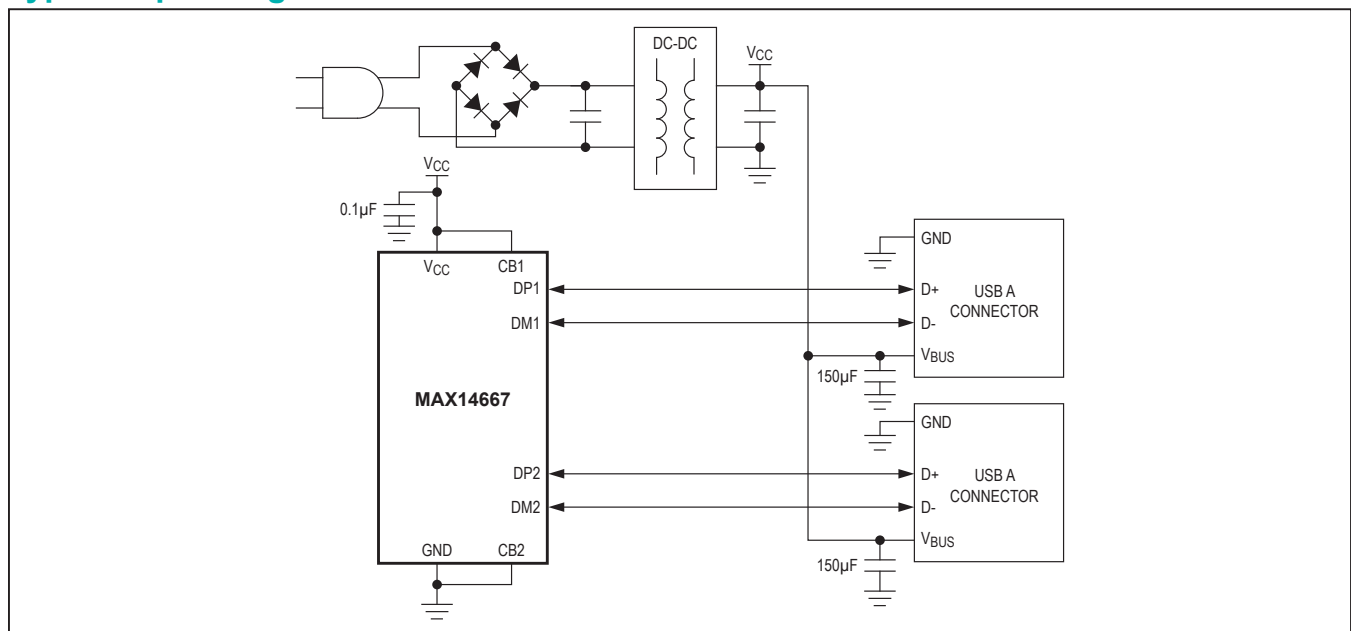

For related parts and recommended products to use with this part, refer to www.maximintegrated.com/MAX14667.related.

Benefits and Features

- Optimized for Charging Adapters
 - Flexible Device and Adapter Connection Order
- Faster Charging
 - Apple 2A Charging Capability
 - Samsung Galaxy Tablet 2A Charging Capability
- Improved Charger Interoperability
 - Meets New USB BC Revision 1.2 Specification
 - Supports Samsung Galaxy Smartphones
 - Backwards Compatible with Previous USB BC Revisions
 - Meets China YD/T1591-2009 Charging Specification
- Greater User Flexibility
 - CB_ Pins Control Charger Mode
- Saves Space on Board
 - 2.9mm x 1.6mm, 8-Pin SOT23 Package
 - High-ESD Human Body Model (HBM) Protection on DP and DM

iPod®/iPad®/iPhone® are registered trademarks of Apple, Inc.

Ordering Information appears at end of data sheet.

Absolute Maximum Ratings

(All voltages referenced to GND.)

V_{CC}, CB₋, DP₋, DM₋.....-0.3V to +6V
 Continuous Current into Any Terminal..... ±50mA
 Continuous Power Dissipation (T_A = +70°C)
 SOT23 (derate 5.2mW/°C above +70°C)412.4mW
 Operating Temperature Range.....-40°C to +85°C

Maximum Junction Temperature +150°C
 Storage Temperature Range -65°C to +150°C
 Lead Temperature (soldering, 10s) +300°C
 Soldering Temperature (reflow) +260°C

Stresses beyond those listed under "Absolute Maximum Ratings" may cause permanent damage to the device. These are stress ratings only, and functional operation of the device at these or any other conditions beyond those indicated in the operational sections of the specifications is not implied. Exposure to absolute maximum rating conditions for extended periods may affect device reliability.

Package Thermal Characteristics (Note 1)

SOT23

Junction-to-Ambient Thermal Resistance (θ_{JA})194°C/W
 Junction-to-Case Thermal Resistance (θ_{JC}).....70°C/W

Note 1: Package thermal resistances were obtained using the method described in JEDEC specification JESD51-7, using a four-layer board. For detailed information on package thermal considerations, refer to www.maximintegrated.com/thermal-tutorial.

Electrical Characteristics

(V_{CC} = 3.0V to 5.5V, T_A = -40°C to +85°C, unless otherwise noted. Typical values are at V_{CC} = +5.0V, T_A = +25°C, unless otherwise noted.) (Notes 2, 3)

PARAMETER	SYMBOL	CONDITIONS	MIN	TYP	MAX	UNITS
POWER SUPPLY						
Operating Power-Supply Range	V _{CC}		3		5.5	V
		Apple/Samsung divider valid range	4.75		5.5	
V _{CC} Supply Current	I _{CC}	V _{CC} = 5.0V		45	65	µA
Power-On Reset	POR			1.5		V
POR Delay	t _{POR}			100		ms
ANALOG SWITCH						
Analog Signal Range	V _{DP-} , V _{DM-}		0		V _{CC}	V
On-Resistance of DP ₋ /DM ₋ Short	R _{SHORT}	V _{DP-} = 0.7V, I _{DM-SINK} = 100µA to GND		4.5	11	Ω
DYNAMIC						
CB ₋ Switching Time	t _{ON}	CB ₋ = V _{CC} to 0, 0 to V _{CC}		4		µs
INTERNAL RESISTORS						
DP ₋ /DM ₋ Short Pulldown	R _{PD}		350	500	700	kΩ
40 V _{CC} Bias	V _{AP1(2)A-P(M)}	V _{CC} = 4.75V, 5.5V	39	40	41	%V _{CC}
54 V _{CC} Bias	V _{AP1(2)A-M(P)}	V _{CC} = 4.75V, 5.5V	52.6	53.6	54.6	%V _{CC}
25 V _{CC} Bias	V _{S5G-P/M}	V _{CC} = 4.75V, 5.5V	24	25	26	%V _{CC}

Electrical Characteristics (continued)

($V_{CC} = 3.0V$ to $5.5V$, $T_A = -40^{\circ}C$ to $+85^{\circ}C$, unless otherwise noted. Typical values are at $V_{CC} = +5.0V$, $T_A = +25^{\circ}C$, unless otherwise noted.) (Notes 2, 3)

PARAMETER	SYMBOL	CONDITIONS	MIN	TYP	MAX	UNITS
LOGIC INPUT (CB)						
CB_ Input Logic High	V_{IH}		1.4			V
CB_ Input Logic Low	V_{IL}				0.4	V
CB_ Input Leakage Current	I_{CB-}	$V_{IN} = 0, V_{IL}, V_{IH}, 5.5V$	-1		+1	μA
ESD PROTECTION						
ESD Protection Level (DP_ and DM_ Only)	V_{ESD}	Human Body Model		± 15		kV
		Contact Model		± 6		

Comparator Characteristics (Note 4)

($V_{CC} = 4.75V$ to $5.5V$, $T_A = -40^{\circ}C$ to $+85^{\circ}C$, unless otherwise noted. Typical values are at $V_{CC} = +5.0V$, $T_A = +25^{\circ}C$, unless otherwise noted.) (Note 2)

PARAMETER	SYMBOL	CONDITIONS		MIN	TYP	MAX	UNITS
DM1 Comparator Threshold	V_{DM1F}	DM_ falling	Autodetection 1A	40	41	42	% V_{CC}
			Autodetection 2A	31	32	33	
DM1 Comparator Hysteresis				1			% V_{CC}
DM2 Comparator Threshold	V_{DM2F}	DM_ falling		6.31	7	7.62	% V_{CC}
DM2 Comparator Hysteresis				1			% V_{CC}
DP Comparator Threshold	V_{DPR}	DP_ rising	Autodetection 1A	45	46	47	% V_{CC}
			Autodetection 2A	57	58	59	
DP Comparator Hysteresis				1			% V_{CC}

Note 2: All units are 100% production tested at $T_A = +25^{\circ}C$. Specifications over operating temperature range are guaranteed by design.

Note 3: The device is operational from $3.0V$ to $5.5V$. For the resistor-divider equivalent network to function properly, keep V_{CC} within the $4.75V$ to $5.5V$ range.

Note 4: The comparators are disabled during the POR delay.

Typical Operating Characteristics

($V_{CC} = 5.0V$, $T_A = +25^\circ C$, unless otherwise noted.)

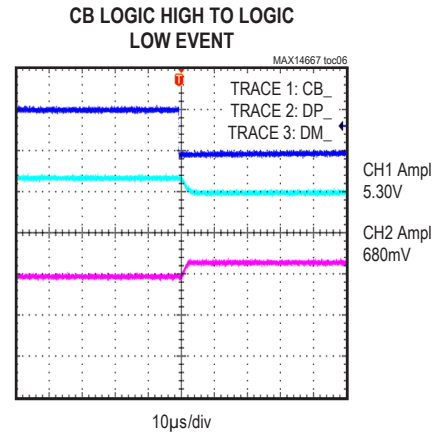
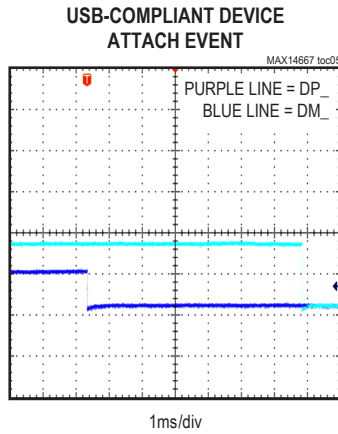
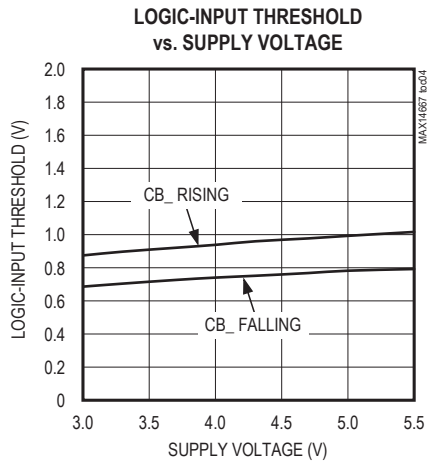
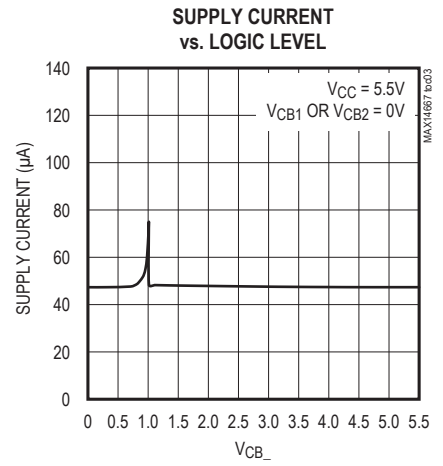
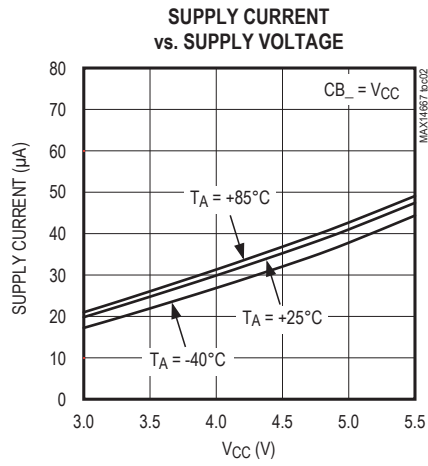
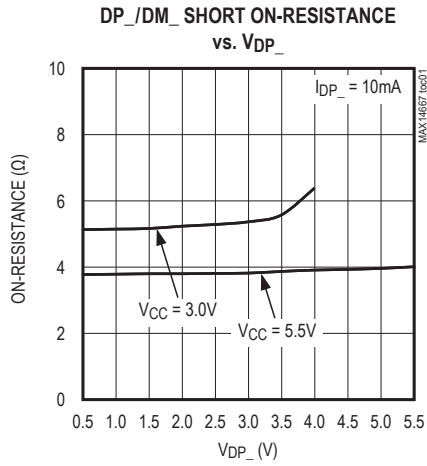

Pin Configuration

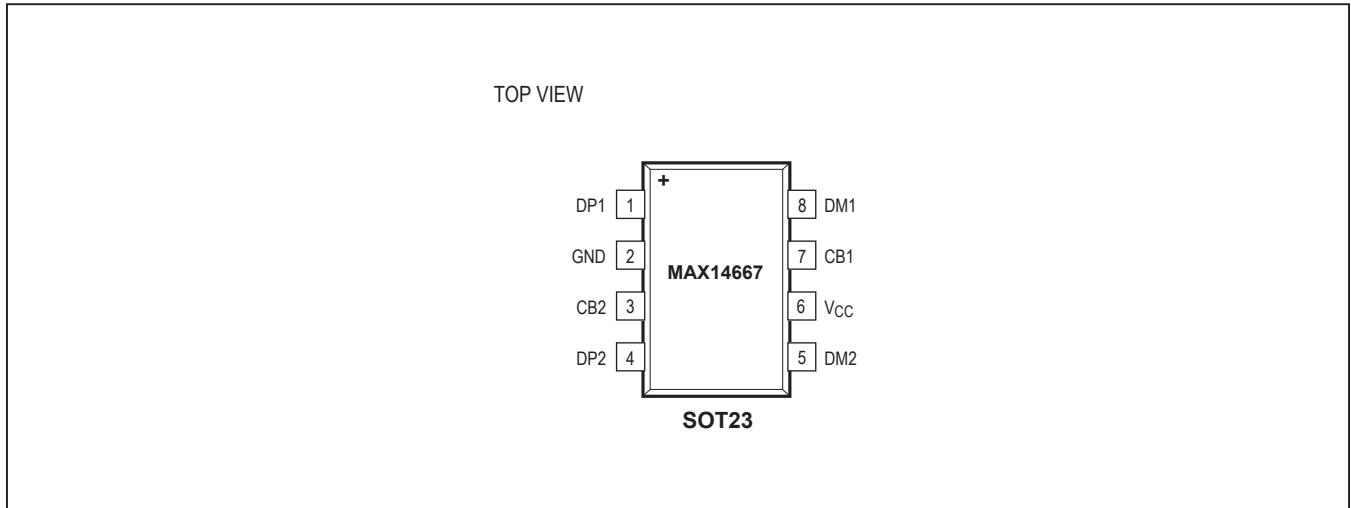

Pin Description

PIN	NAME	FUNCTION
1	DP1	USB D+ Connection for Connector One
2	GND	IC Ground; Return to the Transformer Output
3	CB2	Control Bit for Connector Two
4	DP2	USB D+ Connection for Connector Two
5	DM2	USB D- Connection for Connector Two
6	V _{CC}	Power Supply. Bypass V _{CC} with a 0.1μF ceramic capacitor as close as possible to the pin.
7	CB1	Control Bit for Connector One
8	DM1	USB D- Connection for Connector One

Functional Diagram

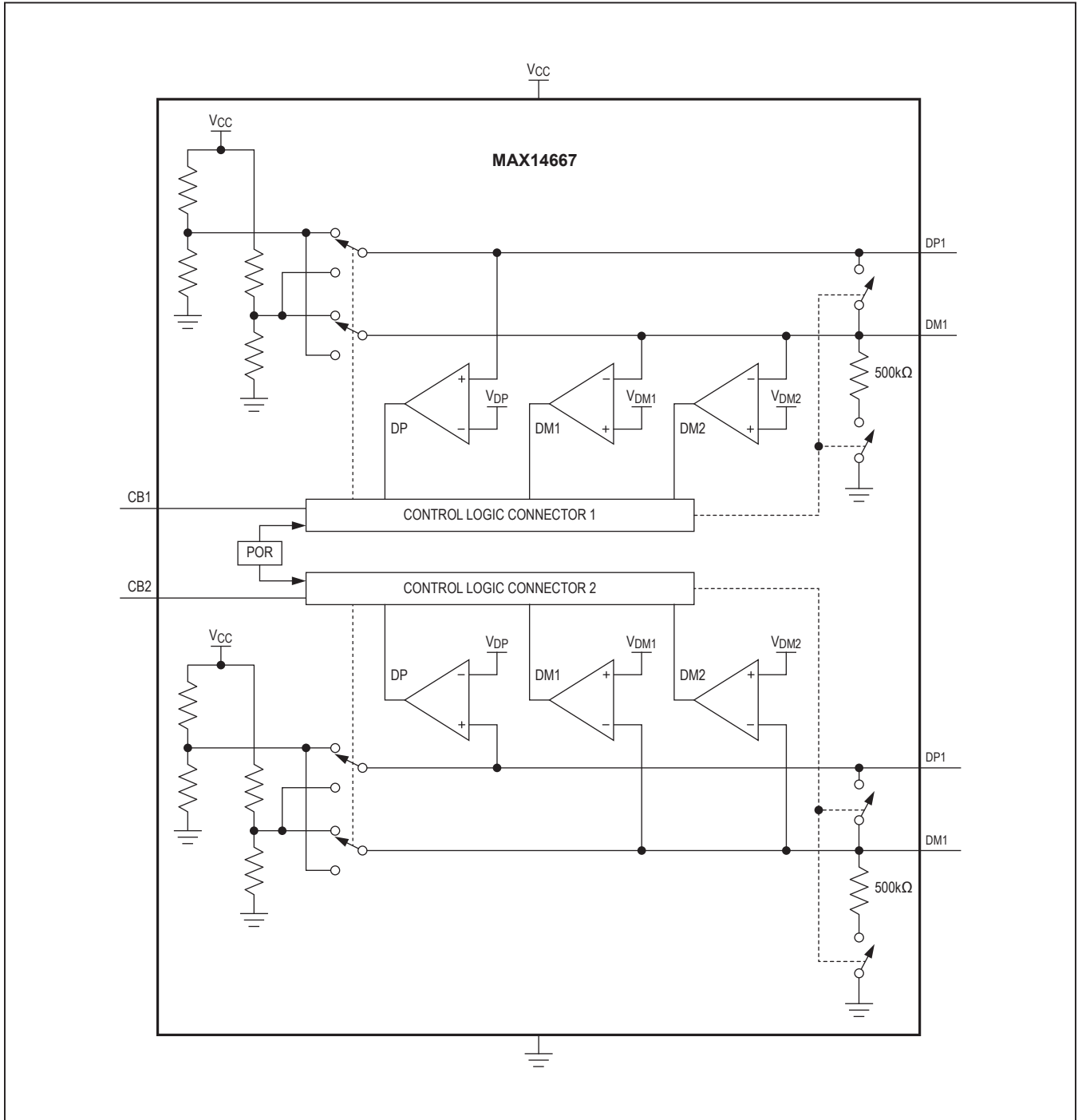

Detailed Description

The MAX14667 is a dual USB host adapter emulator with automatic host charger identification circuitry for USB dedicated chargers.

The device allows USB wall adapters, travel chargers, and other dedicated chargers to identify themselves as a USB-dedicated charger to USB devices, an Apple charger to Apple products, and a Samsung Galaxy tablet dedicated charger port to Samsung Galaxy tablet devices.

Resistor-Dividers

The MAX14667 features internal resistor-divider equivalent networks for biasing data lines to provide support for Apple-compliant devices as well as Samsung Galaxy Tablets.

Mode Control

The device features two digital inputs, CB1 and CB2, for mode selection. Connect CB_n to a logic-level high voltage to place the corresponding channel in autodetection 2A charger mode or to a logic-level low voltage to place the corresponding channel in autodetection 1A charger mode. See Table 1.

Autodetection

The MAX14667 features Autodetection 1A and autodetection 2A for dedicated chargers in which the device monitors the voltages at DM_n and DP_n to determine the type of device attached. When the voltage at DM_n is V_{DM1F} or higher, and the voltage at DP_n is V_{DPR} or lower, the voltage remains unchanged. If the voltage at DM_n is forced below the V_{DM1F} threshold, the internal switch disconnects DM_n and DP_n from the resistor-dividers and

DM_n and DP_n are shorted together for USB-dedicated charging mode. If the Samsung Galaxy Tablet device is connected, DM_n and DP_n are shorted together and connected to the correct resistor-divider for Samsung Galaxy Tablet dedicated charging mode.

Once the charging voltage is removed, the short between DP_n and DM_n is disconnected.

±15kV ESD Protection

As with all Maxim devices, ESD-protection structures are incorporated on all pins to protect against electrostatic discharges encountered during handling and assembly. The DP_n and DM_n lines have extra protection against static electricity. Maxim's engineers have developed state-of-the-art structures to protect these pins against ESD of ±15kV without damage.

The ESD structures withstand high ESD in normal operation and while the device is powered down. After an ESD event, the MAX14667 continues working without latchup, whereas competing products can latch and must be powered down to remove latchup. ESD protection can be tested in various ways. The DP_n and DM_n lines of this product family are characterized for protection to the following limits:

- 1) ±15kV using the Human Body Model
- 2) ±6kV using the Contact Discharge method

ESD Test Conditions

ESD performance depends on a variety of conditions. Contact Maxim for a reliability report that documents test setup, test methodology, and test results.

Table 1. Digital Input State for MAX14667

CB		USB B.C. 1.2 Specification	Samsung Galaxy Tablet	Apple
1	Autodetection 2A	Supports all compliant devices	Charge at 2A	Appears as Apple 2A charger
0	Autodetection 1A	Supports all compliant devices	Charge at 2A	Appears as Apple 1A charger

Ordering Information

PART	TEMP RANGE	PIN-PACKAGE	TOP MARK
MAX14667EKA+T	-40°C to +85°C	8 SOT23	AETH

+Denotes a lead(Pb)-free/RoHS-compliant package.

T = Tape and reel.

Chip Information

PROCESS: BiCMOS

Package Information

For the latest package outline information and land patterns (footprints), go to www.maximintegrated.com/packages. Note that a "+", "#", or "-" in the package code indicates RoHS status only. Package drawings may show a different suffix character, but the drawing pertains to the package regardless of RoHS status.

PACKAGE TYPE	PACKAGE CODE	OUTLINE NO.	LAND PATTERN NO.
8 SOT23	K8+2	21-0078	90-0176

Revision History

REVISION NUMBER	REVISION DATE	DESCRIPTION	PAGES CHANGED
0	6/13	Initial release	—

For pricing, delivery, and ordering information, please contact Maxim Direct at 1-888-629-4642, or visit Maxim Integrated's website at www.maximintegrated.com.

Maxim Integrated cannot assume responsibility for use of any circuitry other than circuitry entirely embodied in a Maxim Integrated product. No circuit patent licenses are implied. Maxim Integrated reserves the right to change the circuitry and specifications without notice at any time. The parametric values (min and max limits) shown in the Electrical Characteristics table are guaranteed. Other parametric values quoted in this data sheet are provided for guidance.