

AM2520EJ/xx SERIES

### Features

- HIGH RELIABILITY
- BLACK CASE ENHANCES CONTRAST.
- VIBRATION AND SHOCK RESISTANT.
- AVAILABLE WITH A VARIETY OF LEDs.
- UL RATING : 94V-0.
- HOUSING MATERIAL: TYPE 66 NYLON.

### Description

The High Efficiency Red source color devices are made with Gallium Arsenide Phosphide on Gallium Phosphide Orange Light Emitting Diode.

The Super Bright Green source color devices are made with Gallium Phosphide Green Light Emitting Diode.

The Yellow source color devices are made with Gallium Arsenide Phosphide on Gallium Phosphide Yellow Light Emitting Diode.

### Package Dimensions

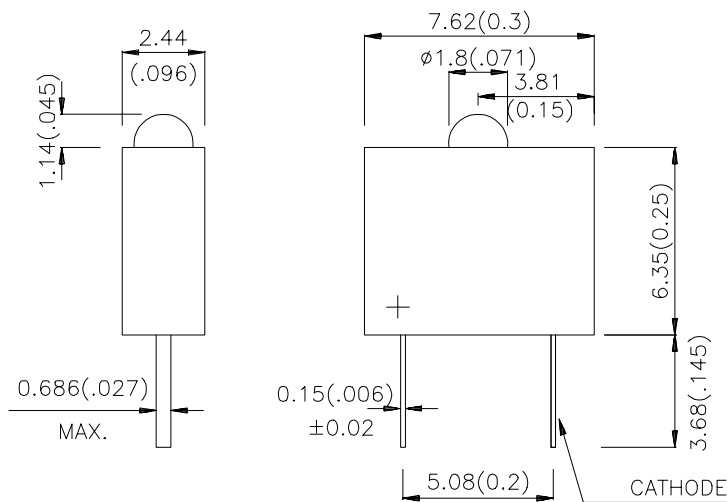

#### Notes:

1. All dimensions are in millimeters (inches).
2. Tolerance is  $\pm 0.25 (0.01)$  unless otherwise noted.
3. Lead spacing is measured where the lead emerge package.
4. Specifications are subject to change without notice.

## Selection Guide

Part No.	Dice	Lens Type	Iv (mcd) @ 20 mA		Viewing Angle
			Min.	Typ.	2θ1/2
AM2520EJ/ID	HIGH EFFICIENCY RED (GaAsP/GaP)	RED DIFFUSED	8	30	40°
AM2520EJ/YD	YELLOW (GaAsP/GaP)	YELLOW DIFFUSED	3	10	40°
AM2520EJ/SGD	SUPER BRIGHT GREEN (GaP)	GREEN DIFFUSED	3	10	40°

Note:

1. θ1/2 is the angle from optical centerline where the luminous intensity is 1/2 the optical centerline value.

## Electrical / Optical Characteristics at T<sub>A</sub>=25°C

Symbol	Parameter	Device	Typ.	Max.	Units	Test Conditions
λ <sub>peak</sub>	Peak Wavelength	High Efficiency Red Super Bright Green Yellow	627 565 590		nm	IF=20mA
λ <sub>D</sub>	Dominate Wavelength	High Efficiency Red Super Bright Green Yellow	625 568 588		nm	IF=20mA
Δλ <sub>1/2</sub>	Spectral Line Halfwidth	High Efficiency Red Super Bright Green Yellow	45 30 35		nm	IF=20mA
C	Capacitance	High Efficiency Red Super Bright Green Yellow	15 15 20		pF	VF=0V;f=1MHz
V <sub>F</sub>	Forward Voltage	High Efficiency Red Super Bright Green Yellow	2.0 2.2 2.1	2.5 2.5 2.5	V	IF=20mA
I <sub>R</sub>	Reverse Current	All		10	uA	VR = 5V

## Absolute Maximum Ratings at T<sub>A</sub>=25°C

Parameter	High Efficiency red	Super Bright Green	Yellow	Units
Power dissipation	105	105	105	mW
DC Forward Current	30	25	30	mA
Peak Forward Current [1]	160	140	140	mA
Reverse Voltage	5	5	5	V
Operating Temperature	-40°C To +85°C			
Storage Temperature	-40°C To +85°C			
Lead Solder Temperature [2]	260°CFor 5 Seconds			

Notes:

- 1/0 Duty Cycle, 0.1ms Pulse Width.
- 4mm below package base.

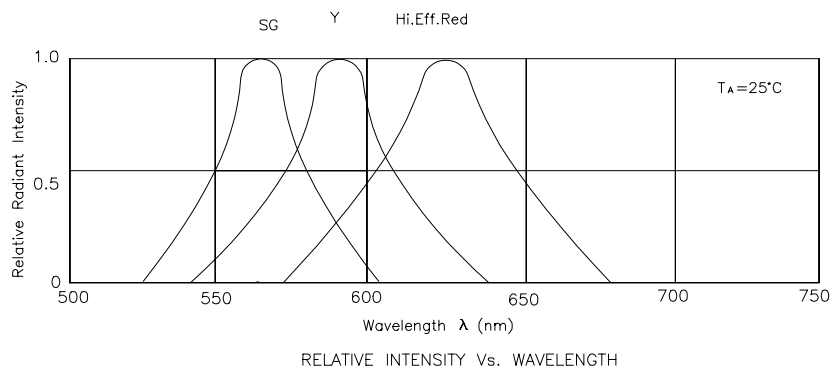

## High Efficiency Red AM2520EJ/ID

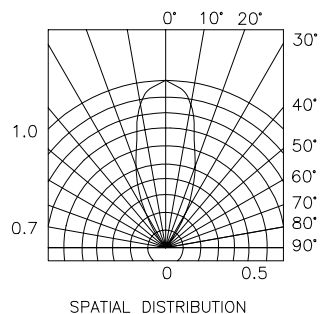
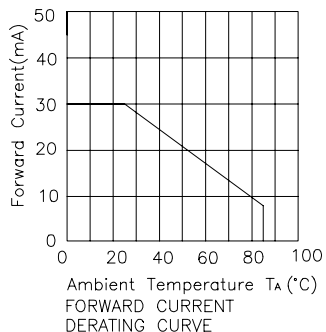
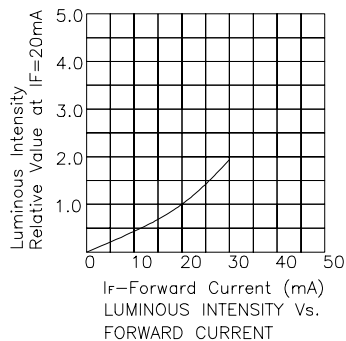
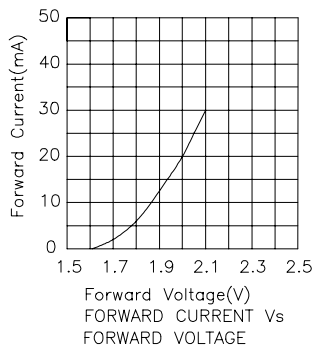

## Super Bright Green AM2520EJ/SGD

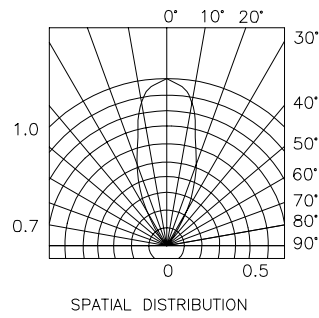
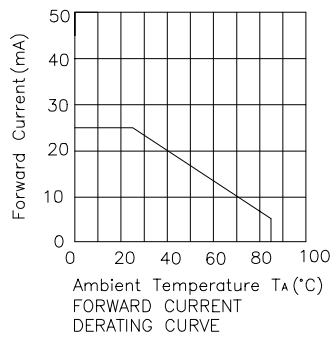
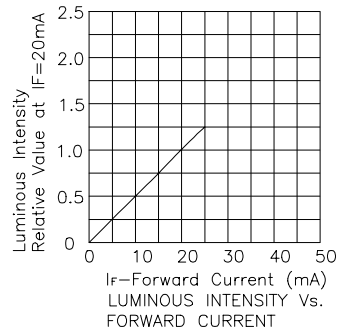
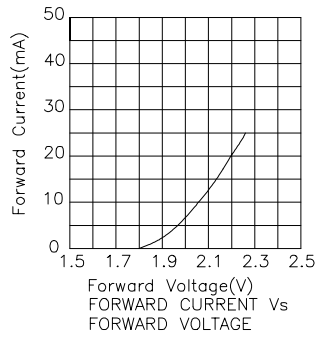

## Yellow AM2520EJ/YD

