

## OVERVIEW

The SMD-01 is a high-precision optical encoder that employs a diffraction image projection method. It incorporates an OEIC (Opto-Electric Integrated Circuit) and LED light source in a single package. Light emitted from the LED is projected onto a scale, and the reflected diffraction image is focused on a photodiode. The reflected light contains position information that is recovered to detect the relative movement between the SMD-01 and the scale. In addition, the light receiver employs a photodiode array to reduce the degradation in phase characteristics due to dependency on mounting position error, making the SMD-01 easier to mount.

## FEATURES

- Package: Miniature clear-mold package (5.3 × 4.3 × 1.68mm)
- Output signal period: 20μm (Uses 20μm period A-phase/B-phase signals to achieve 5μm resolution)
- Optimized OEIC and optics design for easy mounting alignment
- LED and OEIC fabricated in a single package
- Adjustable LED brightness using external inputs
- Analog (sine wave) output
- Supply voltage: 3.13 to 5.25V
- Current consumption: 12.2mA (typ)

## APPLICATIONS

- Linear motors
- Precision stages
- Sliders
- Mounting equipment
- Robots
- Angle measurement equipment
- Various encoder devices

## PINOUT

(Top view)

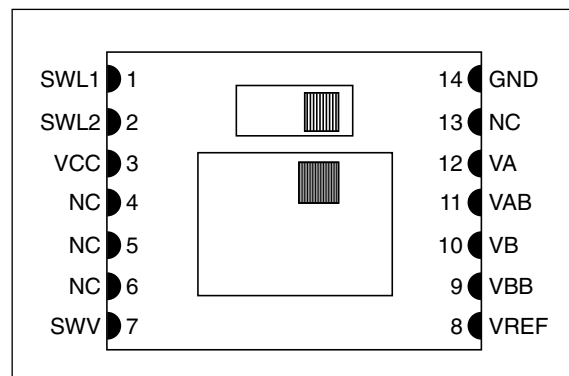

## PACKAGE DIMENSIONS

(Unit: mm)

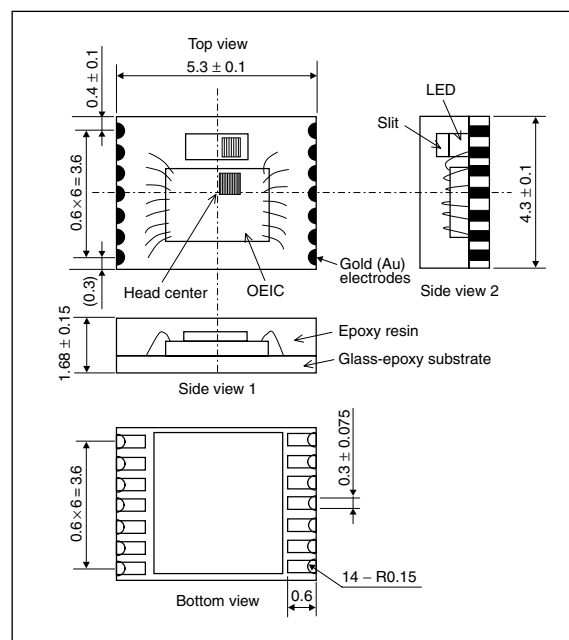

## BLOCK DIAGRAM

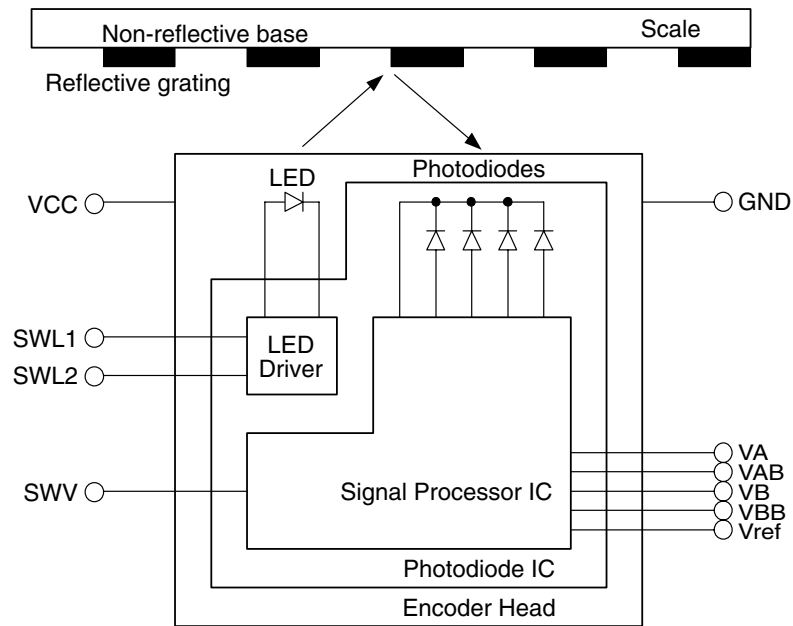

## PIN DESCRIPTION

Number	Name	I/O <sup>*1</sup>	Description
1	SWL1	Ip	LED brightness adjustment 1
2	SWL2	Ip	LED brightness adjustment 2
3	VCC	-	Supply voltage (+)
4	NC	-	No connection (leave open circuit)
5	NC	-	No connection (leave open circuit)
6	NC	-	No connection (leave open circuit)
7	SWV	Ip	Reference voltage (VREF) select input HIGH: VREF = 1.45V (typ) LOW: VREF = 2.25V (typ)
8	VREF	O	Reference voltage output
9	VBB	O	B-phase inverted analog signal (BB phase) output
10	VB	O	B-phase analog signal output
11	VAB	O	A-phase inverted analog signal (AB phase) output
12	VA	O	A-phase analog signal output
13	NC	-	No connection (leave open circuit)
14	GND	-	Ground

\*1. Ip: input with built-in pull-up resistor

## SPECIFICATIONS

### Absolute Maximum Ratings

Parameter	Symbol	Rating	Unit
Supply voltage*1	$V_{CC}$	- 0.3 to +5.5	V
Storage temperature*2	$T_{STG}$	- 40 to +80	°C

\*1. This parameter rating is the values that must never exceed even for a moment. The device may be damaged or deteriorated the characteristics or reliability if this parameter rating is exceeded.

\*2. The device may be deteriorated the characteristics or reliability if this parameter rating is exceeded.

Note. Condensation free

### Recommended Operating Conditions

Parameter	Symbol	Rating	Unit
Supply voltage	$V_{CC}$	3.13 to 5.25	V
Operating temperature	$T_a$	-20 to +60	°C
Response speed	$R_t$	0 to 2	m/s

Note. Since it may influence the reliability if it is used out of range of recommended operating conditions, this product should be used within this range.

Condensation free

## Electrical Characteristics

$V_{CC} = 5V$ ,  $T_a = 27^\circ C$ , unless otherwise noted.

Parameter	Pins	Symbol	Condition	Rating			Unit
				min	typ	max	
Current consumption 1	VCC	$I_{CC1}$	SWL1 = HIGH, SWL2 = HIGH	4.0	12.2	23.0	mA
Current consumption 2		$I_{CC2}$	SWL1 = HIGH, SWL2 = LOW	7.0	16.9	30.0	mA
Current consumption 3		$I_{CC3}$	SWL1 = LOW, SWL2 = HIGH	11.0	21.0	35.5	mA
Current consumption 4		$I_{CC4}$	SWL1 = LOW, SWL2 = LOW	2.0	6.0	13.5	mA
Reference voltage	VREF	Vref	SWV = HIGH	1.00	1.45	2.00	V
			SWV = LOW	1.40	2.25	3.20	V
A-phase output signal amplitude	VA	VAP-P	Vp-p, SWL1 = HIGH, SWL2 = HIGH, Standard scale conditions	0.13	0.85	3.00	V
AB-phase output signal amplitude	VAB	VABP-P					
B-phase output signal amplitude	VB	VBP-P					
BB-phase output signal amplitude	VBB	VBBP-P					
A-phase signal offset voltage	VA	VAO	SWL1 = LOW, SWL2 = LOW, Variation from VREF	-0.25	0.00	0.25	V
AB-phase signal offset voltage	VAB	VABO					
B-phase signal offset voltage	VB	VBO					
BB-phase signal offset voltage	VBB	VBBO					
A-phase – B-phase difference	VA, VB	DP	Standard scale conditions	50	90	130	°
Output voltage fluctuation 1	VREF, VA, VAB, VB, VBB	$\Delta VO1$	Difference between 0 $\mu A$ and 50 $\mu A$ sink current	0	–	+30	mV
Output voltage fluctuation 2		$\Delta VO2$	Difference between 0 $\mu A$ and 50 $\mu A$ source current	-30	–	0	mV
HIGH-level input voltage	SWL1, SWL2, SWV	$V_{IH}$		$0.8V_{CC}$	–	$V_{CC}$	V
LOW-level input voltage		$V_{IL}$		0	–	$0.2V_{CC}$	V
Input current		$I_{o\_SW}$	Input voltage = 0V	1	–	20	$\mu A$

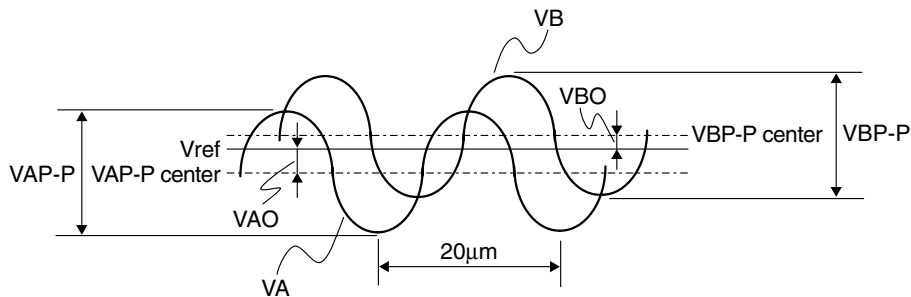

(VAO and VBO offsets represent the differences between the VA and VB amplitude center values and Vref.)

### ■ Standard Scale Conditions

Electrical characteristics ratings apply under the following conditions:

	Parameter	Conditions	Unit
Scale	Reflective surface reflection factor	57	%
	Non-reflective surface reflection factor	5	%
	Pattern	20 $\mu m$ pitch (10 $\mu m$ Cr line/10 $\mu m$ spacing)	–
SMD-01 head alignment	Gap ( $\Delta Gap$ )	0.3	mm
	Yaw angle ( $\Delta \theta_y$ )	0	°
	Roll angle ( $\Delta \theta_r$ )		
Pitch angle ( $\Delta \theta$ )			

## FUNCTIONAL DESCRIPTION

The SMD-01 head emits 635nm center-wavelength visible light from the LED and projects the light through a slit and onto a scale having a 20 $\mu$ m pitch (10 $\mu$ m lines/10 $\mu$ m spacing) grating pattern. The reflected diffraction image is focused on a photodiode array to detect the relative movement between the head and the scale. A 20 $\mu$ m period pseudo sine wave phase A (VA) signal corresponding to the detector state is output, together with phase B (VB), which has 90° phase difference from VA, and inverted signals of both VA & VB (VAB, VBB).

## LED Brightness Switching Function

The signal amplitude can be adjusted by adjusting the LED brightness. The LED brightness is adjusted by adjusting the LED current. The amplitude adjustment options are shown in the following table.

SWL1	H	H	L	L
SWL2	H	L	H	L
A/B-phase analog signal amplitude	$\times 1.0$	$\times 1.8$	$\times 2.6$	$\times 0$

## SCALE and HEAD ALIGNMENT

The encoder head optical center position is offset from the physical center of the head by 0.77mm ( $\Delta Y$ ) in the vertical direction and 0.1mm ( $\Delta X$ ) in the horizontal direction. If using a linear scale, only the offset in the scale width direction ( $\Delta Y$ ) needs to be considered. If using a rotary scale, the scale offset in the horizontal direction ( $\Delta X$ ) must also be taken into account.

Conditions of optimum optics of this product may vary due to mounting tolerance of optical elements, so thorough evaluation is needed to set the conditions. Particularly when using small-diameter rotary scale, effect of alignment conditions on signal amplitude and phase difference is greater than when using linear scale. Individualized alignment is recommended to obtain better product characteristics.

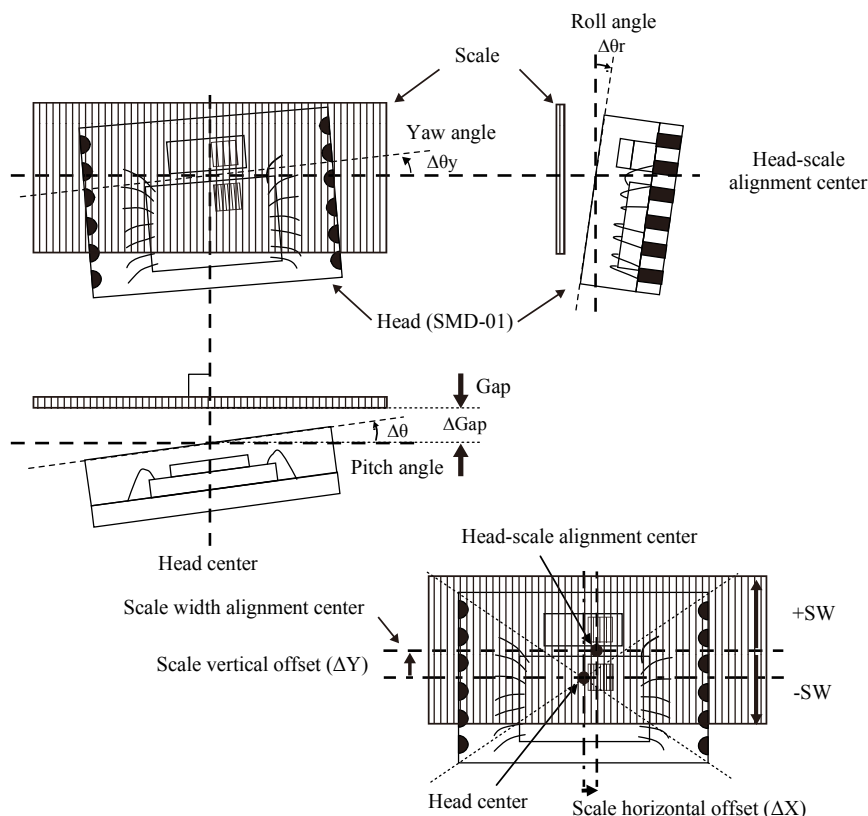

Reference data:

Parameter		Conditions	Unit
Scale	Scale width ( $\pm SW$ )	$\pm 1$ (min)	mm
SMD-01 head alignment	Scale vertical offset ( $\Delta Y$ )	0.77	mm
	Scale horizontal offset ( $\Delta X$ )	0.1	mm

Typical Performances by Scale and Head Alignment

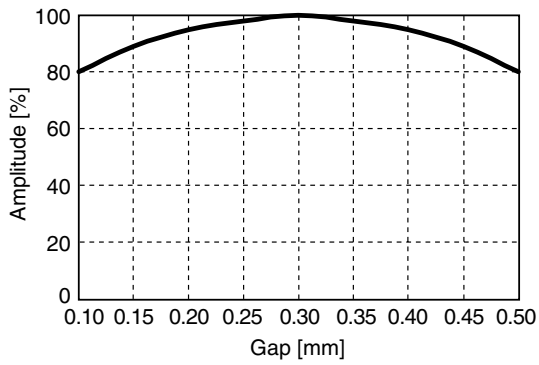

Amplitude vs. Gap ( $\Delta$ Gap)

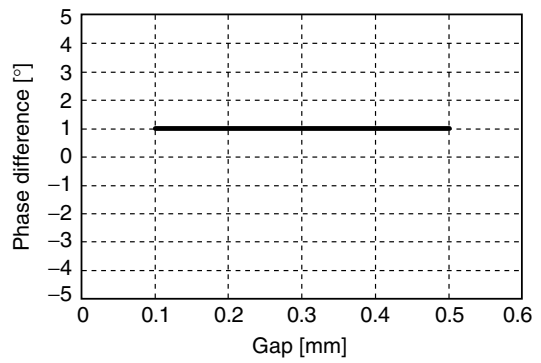

Phase difference vs. Gap ( $\Delta$ Gap)

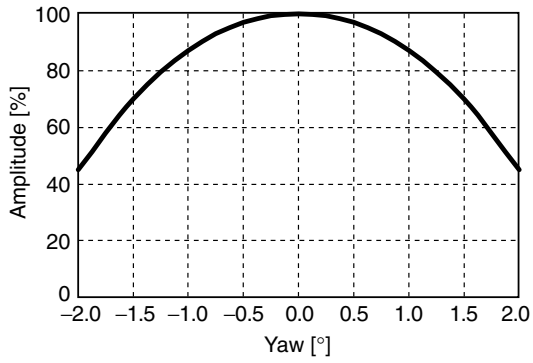

Amplitude vs. Yaw angle ( $\Delta\theta_y$ )

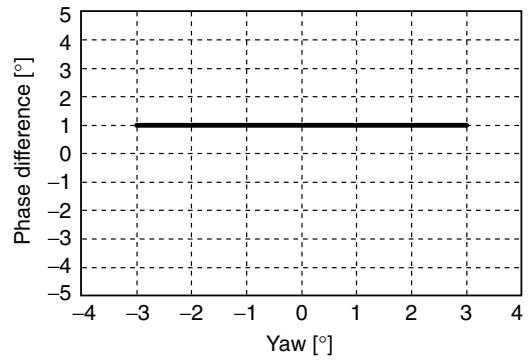

Phase difference vs. Yaw angle ( $\Delta\theta_y$ )

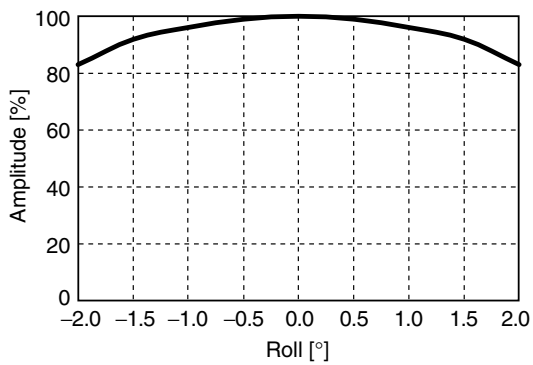

Amplitude vs. Roll angle ( $\Delta\theta_r$ )

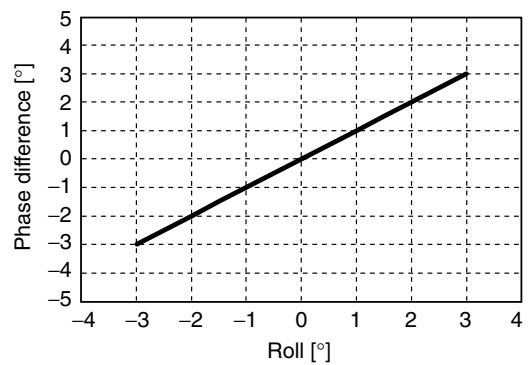

Phase difference vs. Roll angle ( $\Delta\theta_r$ )

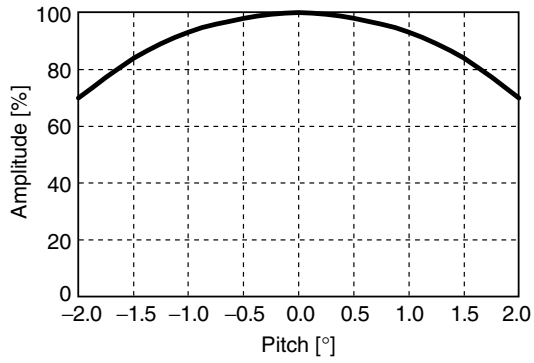

Amplitude vs. Pitch angle ( $\Delta\theta$ )

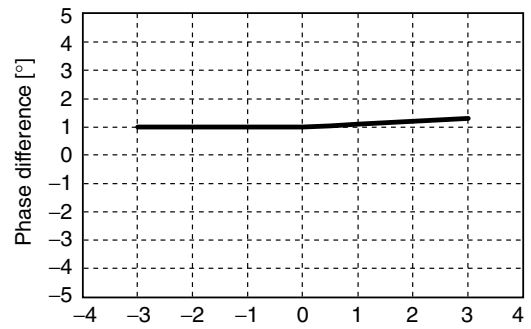

Phase difference vs. Pitch angle ( $\Delta\theta$ )

## TEMPERATURE and FREQUENCY CHARACTERISTICS

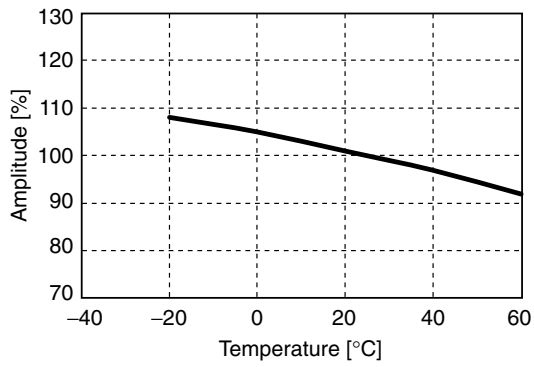

Amplitude vs. Temperature ( $T_a$ )

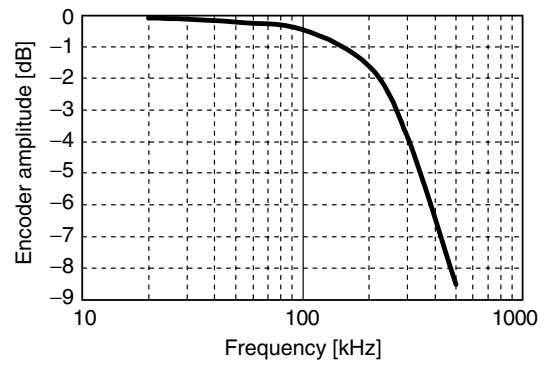

Amplitude vs. Frequency

## PACKAGING

The SMD-01 is supplied on trays. The same trays are designed to withstand the baking temperature before reflow, so the devices can be left on the trays during the baking process.

Note. The trays can be stacked without problem during baking, but tape and labels must first be removed.

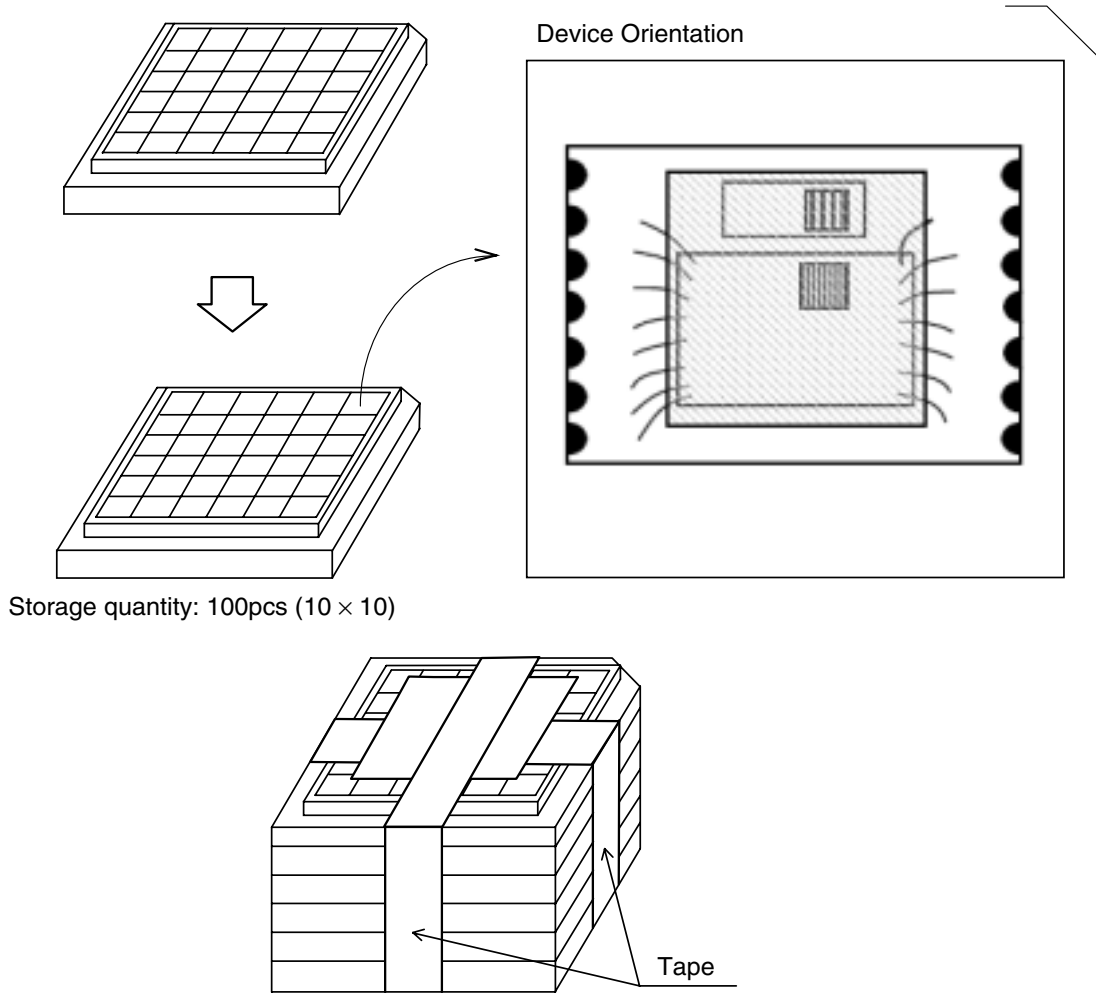



## MOUNTING PRECAUTIONS

Observe the following precautions when mounting the SMD-01.

### Soldering Precautions

- The SMD devices are hygroscopic (moisture absorbing). If the head is soldered after absorbing moisture, the head plastic may crack and the surfaces between the plastic and other materials may separate.
- When soldering, ensure there is no foreign matter adhering to the SMD surface.
- After soldering, ensure that no mechanical stress or strong vibration is applied until the devices reach room temperature.

### Infrared Reflow Method

The following temperature profile conditions are recommended when soldering using the application of heat to the entire device.

#### Temperature profile conditions (Package surface temperature)

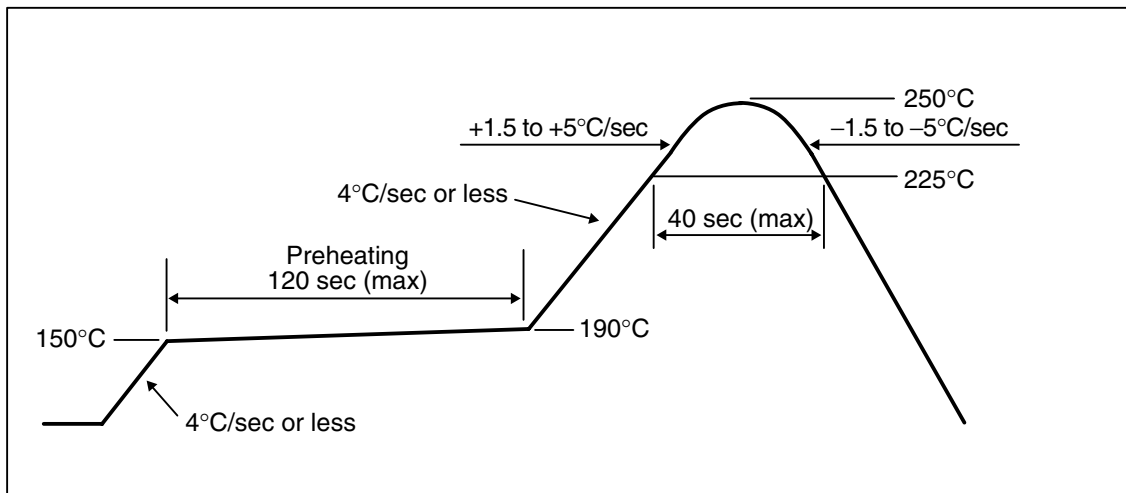

- Before reflow, dry devices at  $125^{\circ}\text{C} \pm 5^{\circ}\text{C}$  for 3 hours, and then reflow in a  $30^{\circ}\text{C} \leq 70\%$  dehydrated atmosphere within 12 hours. Dehydrate devices once only.
- Use a Nitrogen atmosphere in the reflow oven.
- Reflow devices once only.
- Minimize temperature ripples as much as possible during preheating.
- After reflow, the plastic body may be slightly deformed due to heat. Do not touch the devices until they reach room temperature.
- The output signal amplitude before and after reflow may vary greatly, depending on the reflow profile conditions.

Please pay your attention to the following points at time of using the products shown in this document.

1. The products shown in this document (hereinafter "Products") are designed and manufactured to the generally accepted standards of reliability as expected for use in general electronic and electrical equipment, such as personal equipment, machine tools and measurement equipment. The Products are not designed and manufactured to be used in any other special equipment requiring extremely high level of reliability and safety, such as aerospace equipment, nuclear power control equipment, medical equipment, transportation equipment, disaster prevention equipment, security equipment. The Products are not designed and manufactured to be used for the apparatus that exerts harmful influence on the human lives due to the defects, failure or malfunction of the Products.  
If you wish to use the Products in that apparatus, please contact our sales section in advance.  
In the event that the Products are used in such apparatus without our prior approval, we assume no responsibility whatsoever for any damages resulting from the use of that apparatus.
2. NPC reserves the right to change the specifications of the Products in order to improve the characteristics or reliability thereof.
3. The information described in this document is presented only as a guide for using the Products. No responsibility is assumed by us for any infringements of patents or other rights of the third parties which may result from its use. No license is granted by implication or otherwise under any patents or other rights of the third parties. Then, we assume no responsibility whatsoever for any damages resulting from that infringements.
4. The constant of each circuit shown in this document is described as an example, and it is not guaranteed about its value of the mass production products.
5. In the case of that the Products in this document falls under the foreign exchange and foreign trade control law or other applicable laws and regulations, approval of the export to be based on those laws and regulations are necessary. Customers are requested appropriately take steps to obtain required permissions or approvals from appropriate government agencies.

The logo for NPC (Seiko NPC Corporation) consists of the letters 'NPC' in a bold, stylized, sans-serif font. The 'N' and 'P' are connected at the top, and the 'C' is a simple, rounded shape.

**SEIKO NPC CORPORATION**

1-9-9, Hatchobori, Chuo-ku,  
Tokyo 104-0032, Japan  
Telephone: +81-3-5541-6501  
Facsimile: +81-3-5541-6510  
<http://www.npc.co.jp/>  
Email:sales@npc.co.jp

NC0906BE 2015.07