

Connector Designators:

MIL-DTL-38999 Series I, II (F)
 MIL-DTL-38999 Series III and IV (H)

F-H

SELF-LOCKING

ROTATABLE

COUPLING

TYPE D INDIVIDUAL

OR OVERALL

SHIELD TERMINATION

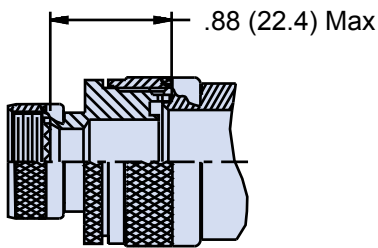
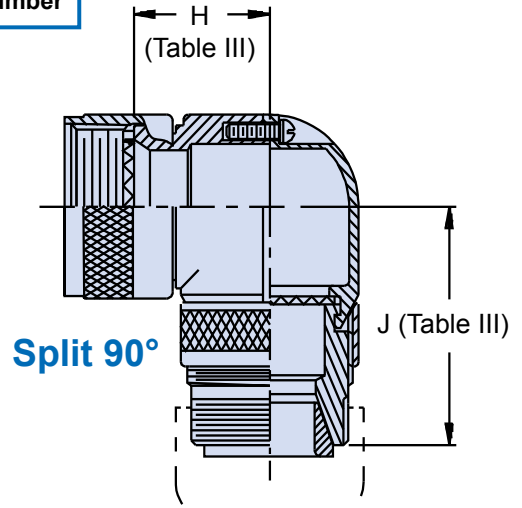
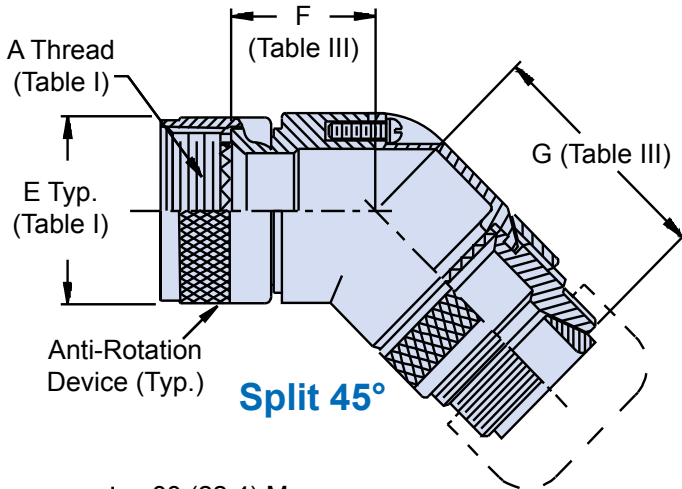
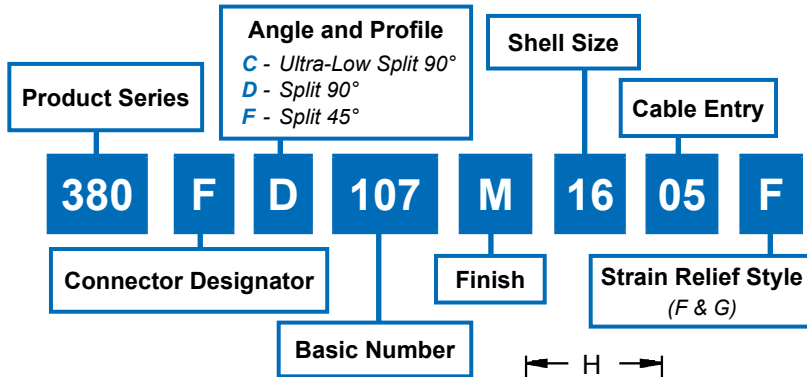

STYLE 2
 (See Note 1)

STYLE F
 Light Duty
 (Table IV)

STYLE G
 Light Duty
 (Table V)

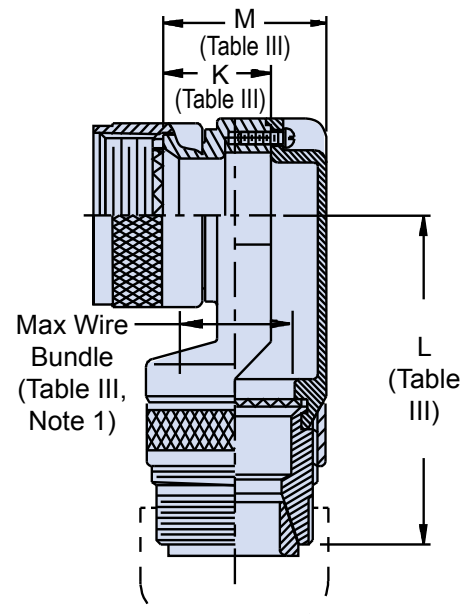
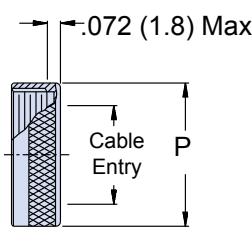
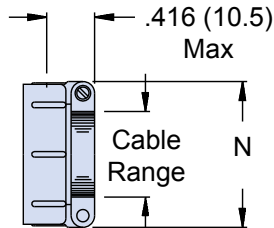

380-107
EMI/RFI Non-Environmental Backshell
 with Strain Relief
 Type D - Self-Locking - Rotatable Coupling - Split Shell



Shell Size	F Max	G Max	H Max	J Max	K Max	L Max	M Max	Function C Max Wire Bundle
08/09	.596 (15.1)	1.730 (43.9)	.836 (21.2)	1.670 (42.4)	.496 (12.6)	1.920 (48.8)	.837 (21.3)	250 (6.4)
10/11	.656 (16.7)	1.785 (45.3)	.906 (23.0)	1.725 (43.8)	.426 (10.8)	2.080 (52.8)	.887 (22.5)	.375 (9.5)
12/13	.716 (18.2)	1.855 (47.1)	.966 (24.5)	1.795 (45.6)	.426 (10.8)	2.080 (52.8)	.887 (22.5)	.375 (9.5)
14/15	.776 (19.7)	1.887 (47.9)	1.026 (26.1)	1.827 (46.4)	.436 (11.1)	2.150 (54.6)	.987 (25.1)	.500 (12.7)
16/17	.836 (21.2)	1.987 (50.5)	1.086 (27.6)	1.927 (48.9)	.576 (14.6)	2.200 (55.9)	1.137 (28.9)	.625 (15.9)
18/19	.906 (23.0)	2.045 (51.9)	1.156 (29.4)	1.985 (50.4)	.796 (20.2)	2.230 (56.6)	1.337 (34.0)	.625 (15.9)
20/21	.976 (24.8)	2.106 (53.5)	1.216 (30.9)	2.046 (52.0)	.796 (20.2)	2.230 (56.6)	1.337 (34.0)	.625 (15.9)
22/23	1.036 (26.3)	2.167 (55.0)	1.276 (32.4)	2.107 (53.5)	.696 (17.7)	2.380 (60.5)	1.337 (34.0)	.750 (19.1)
24/25	1.096 (27.8)	2.225 (56.5)	1.336 (33.9)	2.165 (55.0)	.696 (17.7)	2.380 (60.5)	1.337 (34.0)	.750 (19.1)

Symbol	Finish
B	Cadmium Plate, Olive Drab
C	Anodize, Black
GB	Black Anodize, Hard Coat
M	Electroless Nickel
N	Cad Plate, Olive Drab over Electroless Nickel
NF	Cadmium Plate, Olive Drab over Electroless Nickel
MT	Ni-PTFE 1000 Hour Grey™ Nickel Fluorocarbon Polymer
ZN	Zinc-Nickel

Dash No.	N Max	Cable Range	
		Min	Max
02	.968 (24.6)	.125 (3.2)	.250 (6.4)
03	1.046 (26.6)	.250 (6.4)	.375 (9.5)
04	1.156 (29.4)	.312 (7.9)	.500 (12.7)
05	1.218 (30.9)	.437 (11.1)	.625 (15.9)
06	1.343 (34.1)	.562 (14.3)	.750 (19.1)
07	1.468 (37.3)	.687 (17.4)	.875 (22.2)
08	1.593 (40.5)	.812 (20.6)	1.000 (25.4)
10	1.843 (46.8)	1.062 (27.0)	1.250 (31.8)

Dash No.	N Max	Cable Entry Max
02	.656 (16.7)	.125 (3.2)
03	.781 (19.8)	.250 (6.4)
04	.906 (23.0)	.375 (9.5)
05	1.031 (26.2)	.500 (12.7)
06	1.156 (29.4)	.625 (15.9)
07	1.281 (32.5)	.750 (19.1)
08	1.406 (35.7)	.875 (22.2)
09	1.531 (38.9)	1.000 (25.4)
10	1.656 (42.1)	1.125 (28.6)

APPLICATION NOTES

1. When maximum cable entry is exceeded (not available in Function C), Style 2 will be supplied. Dimensions F, G, H and J will not apply. Please consult factory.
2. Cable range is defined as the accommodations range for the wire bundle or cable.
3. Dimensions shown are not intended for inspection criteria.
4. Angular function "C", low-profile split elbow, not available with "S" connector designator.
5. Metric dimensions (mm) are indicated in parentheses.