

■ General Description

The AME5250 is a high efficiency monolithic synchronous buck regulator using a constant frequency, current mode architecture. Capable of delivering 1A output current over a wide input voltage range from 2.5V to 5.5V, the AME5250 is ideally suited for single Li-Ion battery powered applications. 100% duty cycle provides low dropout operation, extending battery life in portable systems. Under light load conditions, the AME5250 operates in a power saving mode that consumes just around 20μA of supply current, maximizing battery life in portable applications.

The internal synchronous switch increases efficiency and eliminates the need for an external Schottky diode. Low output voltages are easily supported with the 0.6V feedback reference voltage. The AME5250 is available in small DFN-6D & QFN-16C packages.

Other features include soft start, lower internal reference voltage with 2% accuracy, over temperature protection, and over current protection.

■ Features

- High Efficiency: Up to 95%
- Very Low 20μA Quiescent Current
- High efficiency in light load condition
- 2.5V to 5.5V Input Range
- Adjustable Output From 0.6V to V_{IN}
- 1.0V, 1.2V, 1.5V, 1.6V, 1.8V, 2.5V and 3.3V Fixed/Adjustable Output Voltage
- 1A Output Current
- Low Dropout Operation: 100% Duty Cycle
- No Schottky Diode Required
- 1.5MHz Constant Frequency PWM Operation
- Small DFN-6D & QFN-16C Packages
- All AME's Lead Free Product Meet RoHS Standard

■ Applications

- Cellular Telephones
- Personal Information Appliances
- Wireless and DSL Modems
- MP3 Players
- Portable Instruments

■ Typical Application

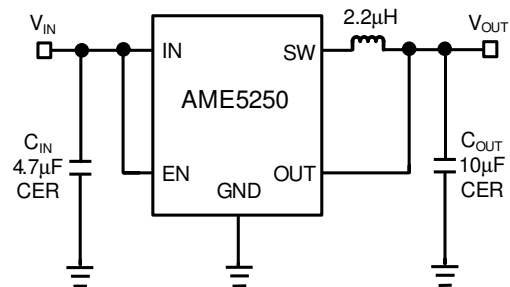

Fixed Output Voltage

Figure 1. High Efficiency Step-Down Converter

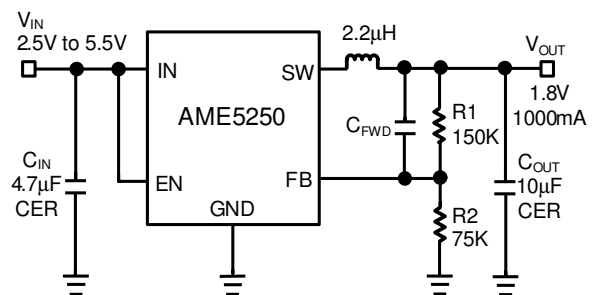

$$V_{OUT} = V_{FB} (R1 + R2) / R2$$

Adjustable Output Voltage

Figure 2. 1.8V at 1000mA Step-Down Regulator

$$C_{FWD}: 22\text{pF} \sim 220\text{pF}$$

■ Function Block Diagram

Figure 3. Function Block Diagram

■ Pin Configuration

DFN-6D
(2mmx2mmx0.75mm)
Top View

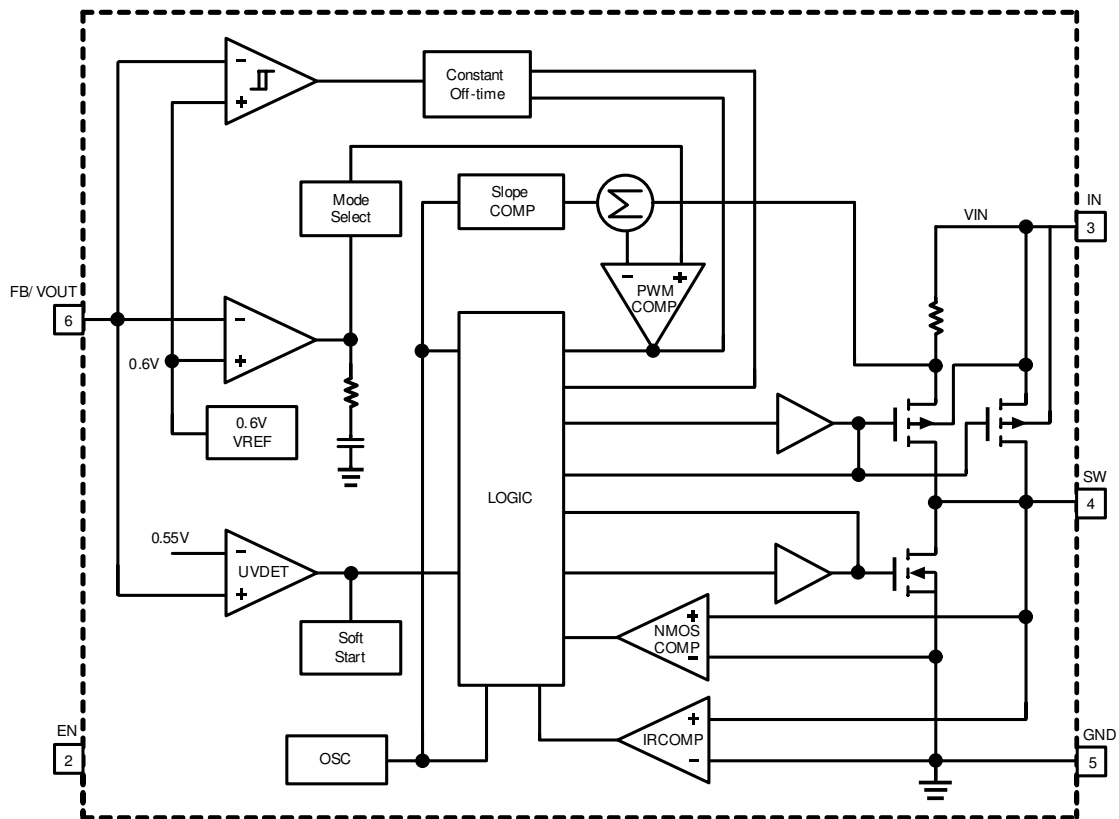
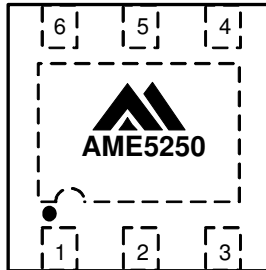

AME5250-AVYxxx

1. NC
2. EN
3. IN
4. SW
5. GND
6. FB/OUT

* Die Attach:
Conductive Epoxy

QFN-16C
(3mmx3mmx0.75mm)
Top View

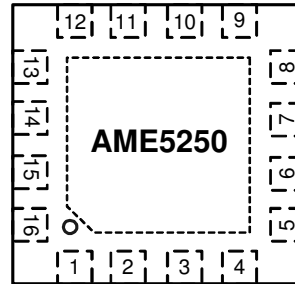

AME5250-AWExxx

- | | |
|-----------|--------|
| 1. GND | 9. IN |
| 2. GND | 10. IN |
| 3. GND | 11. IN |
| 4. FB/OUT | 12. IN |
| 5. GND | 13. SW |
| 6. NC | 14. SW |
| 7. EN | 15. SW |
| 8. NC | 16. NC |

* Die Attach:
Conductive Epoxy

Note:

The area enclosed by dashed line represents Exposed Pad and connect to GND.

■ Pin Description

| Pin Number | | Pin Name | Pin Description |
|------------|---------------|----------|---|
| DFN | QFN | | |
| 1 | 6, 8, 16 | NC | No connection. Not internally connected. Can left floating or connected to GND. |
| 2 | 7 | EN | Enable Control Input, active high. |
| 3 | 9, 10, 11, 12 | IN | Input Supply Voltage Pin. Bypass this pin with a capacitor as close to the device as possible. |
| 4 | 13, 14, 15 | SW | Switch Node Connection to Inductor. |
| 5 | 1, 2, 3, 5 | GND | Ground. Tie directly to ground plane. |
| 6 | 4 | FB/OUT | Output voltage Feedback input. |

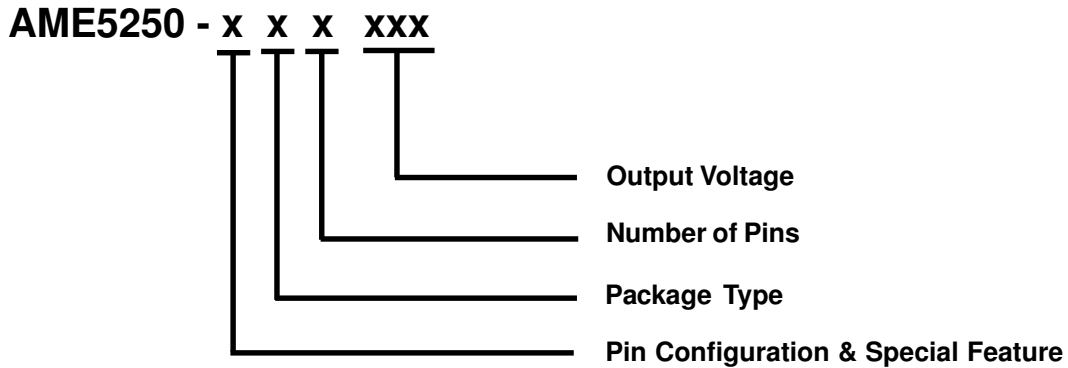
■ Ordering Information

| Pin Configuration & Special Feature | Package Type | Number of Pins | Output Voltage |
|--|------------------|----------------|--|
| A (DFN-6D) 1. NC 2. EN 3. IN 4. SW 5. GND 6. FB/OUT | V: DFN W: QFN | Y: 6 E: 16 | 100: 1.0V 120: 1.2V 150: 1.5V 160: 1.6V 180: 1.8V 250: 2.5V 330: 3.3V ADJ: Adjustable |
| A (QFN-16C) 1. GND 2. GND 3. GND 4. FB/OUT 5. GND 6. NC 7. EN 8. NC 9. IN 10. IN 11. IN 12. IN 13. SW 14. SW 15. SW 16. NC | | | |

■ Available Options

| Part Number | Marking* | Output Voltage | Package | Operating Ambient Temperature Range |
|----------------|-----------------|----------------|---------|-------------------------------------|
| AME5250-AVYADJ | 5250 AMXX | ADJ | DFN-6D | -40°C to +85°C |
| AME5250-AVY120 | 5250 BMXX | 1.2V | DFN-6D | -40°C to +85°C |
| AME5250-AVY180 | 5250 CMXX | 1.8V | DFN-6D | -40°C to +85°C |
| AME5250-AVY330 | 5250 DMXX | 3.3V | DFN-6D | -40°C to +85°C |
| AME5250-AWEADJ | A5250 AMyMXX | ADJ | QFN-16C | -40°C to +85°C |

Note:

1. The first 1 or 2 places represent product code. It is assigned by AME such as A or AM.
2. y is year code and is the last number of a year. Such as the year code of 2008 is 8.
3. A bar on top of first letter represents Green Part such as $\bar{5}250$ or $\bar{A}5250$.
4. The last 3 places MXX represent Marking Code. It contains M as date code in "month", XX as LN code and that is for AME internal use only. Please refer to date code rule section for detail information.
5. Please consult AME sales office or authorized Rep./Distributor for the availability of output voltage and package type.

■ Absolute Maximum Ratings

| Parameter | Symbol | Maximum | Unit |
|-----------------------|-------------------|------------------|------|
| Input Supply Voltage | V_{IN} | -0.3 to 6.5 | V |
| EN, V_{OUT} Voltage | V_{EN}, V_{OUT} | -0.3 to V_{IN} | |
| SW Voltage | V_{SW} | -0.3 to V_{IN} | |
| ESD Classification | B* | | |

Caution: Stress above the listed absolute maximum rating may cause permanent damage to the device.

* HBM B: 2000V~3999V

■ Recommended Operating Conditions

| Parameter | Symbol | Rating | Unit |
|----------------------------|----------|-------------|------|
| Supply Voltage | V_{IN} | 2.5 to 5.5 | V |
| Ambient Temperature Range | T_A | -40 to +85 | °C |
| Junction Temperature Range | T_J | -40 to +125 | °C |

■ Thermal Information

| Parameter | Package | Die Attach | Symbol | Maximum | Unit |
|---|---------|------------------|---------------|---------|--------|
| Thermal Resistance* (Junction to Case) | DFN-6D | Conductive Epoxy | θ_{JC} | 85 | °C / W |
| Thermal Resistance (Junction to Ambient) | | | θ_{JA} | 160 | |
| Internal Power Dissipation | | | P_D | 625 | |
| Thermal Resistance* (Junction to Case) | QFN-16C | Conductive Epoxy | θ_{JC} | 67 | °C / W |
| Thermal Resistance (Junction to Ambient) | | | θ_{JA} | 149 | |
| Internal Power Dissipation | | | P_D | 670 | |
| Solder Iron (10Sec)** | | | | 350 | °C |

* Measure θ_{JC} on backside center of Exposed Pad.

** MIL-STD-202G 210F

■ Electrical Specifications

$V_{IN}=3.6V$, $V_{OUT}=2.5V$, $V_{FB}=0.6V$, $L=2.2\mu H$, $C_{IN}=4.7\mu F$, $C_{OUT}=10\mu F$, $T_A=25^\circ C$, $I_{MAX}=1A$ unless otherwise specified.

| Parameter | Symbol | Test Condition | Min | Typ | Max | Units |
|--|------------------|--|----------|------|--------------|------------|
| Input voltage | V_{IN} | | 2.5 | | 5.5 | V |
| Output Voltage Accuracy | ΔV_{OUT} | $V_{IN}=2.5$ to $5.5V$, in PWM mode For Fixed Output Voltage | -3 | | 3 | % |
| Adjustable Output Range | V_{out} | | V_{FB} | | $V_{IN}-0.2$ | V |
| Feedback Voltage | V_{FB} | For Adjustable Output Voltage | 0.588 | 0.6 | 0.612 | V |
| Feedback Pin Bias Current | I_{FB} | $V_{FB}=V_{IN}$ | -50 | | 50 | nA |
| Quiescent Current (For Adjustable Output Voltage) | I_Q | $I_{OUT}=0mA$, $V_{FB}=1V$ | | 20 | 35 | μA |
| Quiescent Current (For Fixed Output Voltage) | I_Q | $I_{OUT}=0mA$, in PFM mode | | 35 | 40 | μA |
| Shutdown Current | I_{SHDN} | $V_{EN}=GND$ | | 0.1 | 1 | μA |
| Switch Frequency | f_{OSC} | | 1.2 | 1.5 | 1.8 | MHz |
| High-side Switch On-Resistance | $R_{DS,ON, LHI}$ | $I_{SW}=200mA$, $V_{IN}=3.6V$ | | 0.28 | | Ω |
| Low-side Switch On-Resistance | $R_{DS,ON, LO}$ | $I_{SW}=200mA$, $V_{IN}=3.6V$ | | 0.25 | | Ω |
| Switch Current Limit | $I_{SW,CL}$ | $V_{IN}=2.5$ to $5.5V$ | 1.4 | 1.6 | | A |
| EN High (Enabled the Device) | $V_{EN,HI}$ | $V_{IN}=2.5$ to $5.5V$ | 1.5 | | | V |
| EN Low (Shutdown the Device) | $V_{EN,LO}$ | $V_{IN}=2.5$ to $5.5V$ | | | 0.4 | V |
| Input Undervoltage Lockout | V_{UVLO} | rising edge | | 1.8 | | V |
| Input Undervoltage Lockout Hysteresis | $V_{UVLO,HYST}$ | | | 0.1 | | V |
| Thermal Shutdown Temperature | OTP | Shutdown, temperature increasing | | 160 | | $^\circ C$ |
| Maximum Duty Cycle | D_{MAX} | | 100 | | | % |
| SW Leakage Current | | $EN=0V$, $V_{IN}=5.0V$ $V_{SW}=0V$ or $5.0V$ | -1 | | 1 | μA |

■ Detailed Description

Main Control Loop

AME5250 uses a constant frequency, current mode step-down architecture. Both the main (P-channel MOSFET) and synchronous (N-channel MOSFET) switches are internal. During normal operation, the internal top power MOSFET is turned on each cycle when the oscillator sets the RS latch, and turned off when the current comparator resets the RS latch. While the top MOSFET is off, the bottom MOSFET is turned on until either the inductor current starts to reverse as indicated by the current reversal comparator IRCMP.

Short-Circuit Protection

When the output is shorted to ground, the frequency of the oscillator is reduced to about 180KHz. This frequency foldback ensures that the inductor current has more time to decay, thereby preventing runaway. The oscillator's frequency will progressively increase to 1.5MHz when V_{FB} or V_{OUT} rises above 0V.

Dropout Operation

As the input supply voltage decreases to a value approaching the output voltage, the duty cycle increases toward the maximum on-time. Further reduction of the supply voltage forces the main switch to remain on for more than one cycle until it reaches 100% duty cycle. The output voltage will then be determined by the input voltage minus the voltage drop across the P-channel MOSFET and the inductor.

■ Application Information

The basic AME5250 application circuit is shown in Typical Application Circuit. External component selection is determined by the maximum load current and begins with the selection of the inductor value and followed by C_{IN} and C_{OUT} .

Inductor Selection

For a given input and output voltage, the inductor value and operating frequency determine the ripple current. The ripple current ΔI_L increases with higher V_{IN} and decreases with higher inductance.

$$\Delta I_L = \frac{1}{f \times L} \times V_{OUT} \left(1 - \frac{V_{OUT}}{V_{IN}}\right)$$

A reasonable starting point for setting ripple current is $\Delta I_L = 0.4(I_{MAX})$. The DC current rating of the inductor should be at least equal to the maximum load current plus half the ripple current to prevent core saturation. For better efficiency, choose a low DC-resistance inductor.

C_{IN} and C_{OUT} Selection

The input capacitance, C_{IN} is needed to filter the trapezoidal current at the source of the top MOSFET. To prevent large voltage transients, a low ESR input capacitor sized for the maximum RMS current must be used. The maximum RMS capacitor current is given by:

$$I_{RMS} = I_{OUT(MAX)} \times \frac{V_{OUT}}{V_{IN}} \times \sqrt{\frac{V_{IN}}{V_{OUT}} - 1}$$

This formula has a maximum at $V_{IN} = 2V_{OUT}$, where $I_{RMS} = I_{OUT}/2$. This simple worst-case condition is commonly used for design because even significant deviations do not offer much relief. Note that the capacitor manufacturer ripple current ratings are often based on 2000 hours of life. This makes it advisable to further derate the capacitor, or choose a capacitor rated at a higher temperature than required.

The selection of C_{OUT} is determined by the effective series resistance (ESR) that is required to minimize voltage ripple and load step transients. The output ripple, V_{OUT} , is determined by:

$$\Delta V_{OUT} \cong \Delta I_L \left(ESR + \frac{1}{8fC_{OUT}} \right)$$

Using Ceramic Input and Output Capacitors

Higher values, lower cost ceramic capacitors are now becoming available in smaller case sizes. Their high ripple current, high voltage rating and low ESR make them ideal for switching regulator applications. However, care must be taken when these capacitors are used at the input and output. When a ceramic capacitor is used at the input and the power is supplied by a wall adapter through long wires, a load step at the output can induce ringing at the input, V_{IN} . At best, this ringing can couple to the output and be mistaken as loop instability. At worst, a sudden inrush of current through the long wires can potentially cause a voltage spike at V_{IN} large enough to damage the part.

Output Voltage Programming

The output voltage is set by an external resistive divider according to the following equation:

$$V_{OUT} = V_{REF} \times \left(1 + \frac{R1}{R2} \right)$$

Where V_{REF} equals to 0.6V typical. The resistive divider allows the FB pin to sense a fraction of the output voltage as shown in Figure 4.

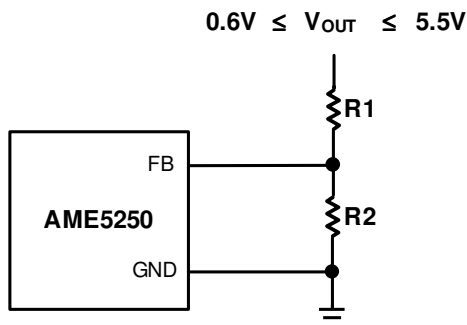

Figure 4. Setting the AME5250 Output Voltage

Thermal Considerations

In most applications the AME5250 does not dissipate much heat due to its high efficiency. But, in applications where the AME5250 is running at high ambient temperature with low supply voltage and high duty cycles, such as in dropout, the heat dissipated may exceed the maximum junction temperature of the part. If the junction temperature reaches approximately 160°C, both power switches will be turned off and the SW node will become high impedance. To avoid the AME5250 from exceeding the maximum junction temperature, the user will need to do some thermal analysis. The goal of the thermal analysis is to determine whether the power dissipated exceeds the maximum junction temperature of the part. The temperature rise is given by:

$$T_R = (PD)(\theta_{JA})$$

Where PD is the power dissipated by the regulator and θ_{JA} is the thermal resistance from the junction of the die to the ambient temperature.

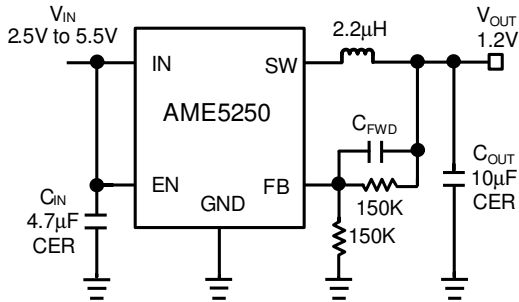

Figure 5. 1.2V Step-Down Regulator
 C_{FWD} : 22pF~220pF

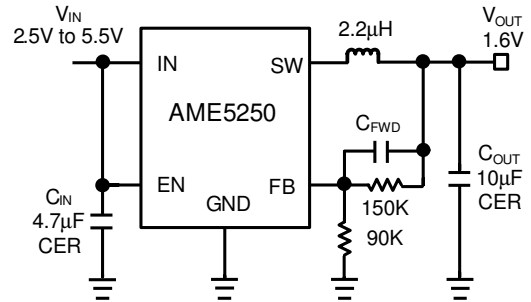

Figure 8. 1.6V Step-Down Regulator
 C_{FWD} : 22pF~220pF

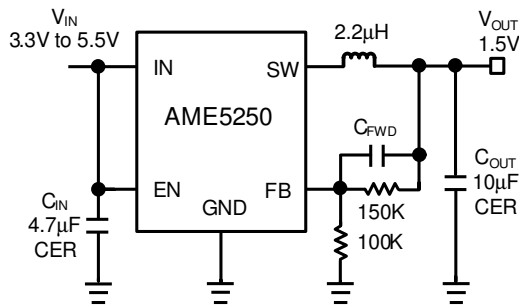

Figure 6. 1.5V Step-Down Regulator
 C_{FWD} : 22pF~220pF

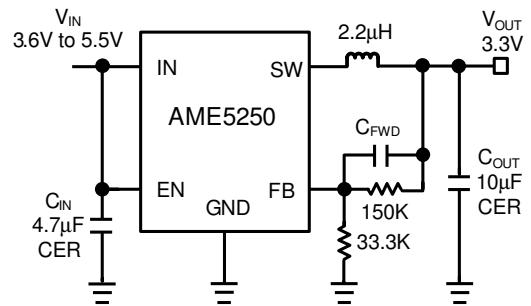

Figure 9. 3.3V Step-Down Regulator
 C_{FWD} : 22pF~220pF

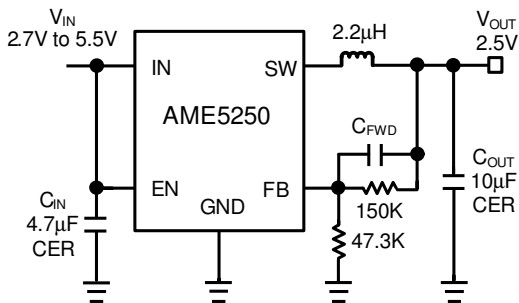

Figure 7. 2.5V Step-Down Regulator
 C_{FWD} : 22pF~220pF

PC Board Layout Checklist

When laying out the printed circuit board, the following checklist should be used to ensure proper operation of the AME5250. These items are also illustrated graphically in Figures 10 and Figures 11 . Check the following in your layout:

1. The power traces, consisting of the GND trace, the SW trace and the V_{IN} trace should be kept short, direct and wide.
2. Does the V_{FB} pin connect directly to the feedback resistors? The resistive divider R2/R1 must be connected between the (+) plate of C_{OUT} and ground.
3. Does the (+) plate of C_{IN} connect to V_{IN} as closely as possible? This capacitor provides the AC current to the internal power MOSFETs.
4. Keep the switching node, SW, away from the sensitive V_{FB} node.
5. Keep the (-) plates of C_{IN} and C_{OUT} as close as possible.

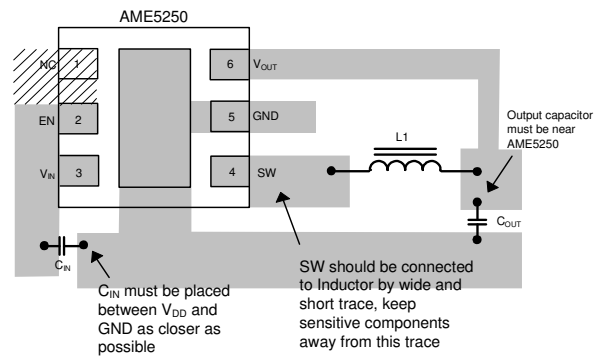
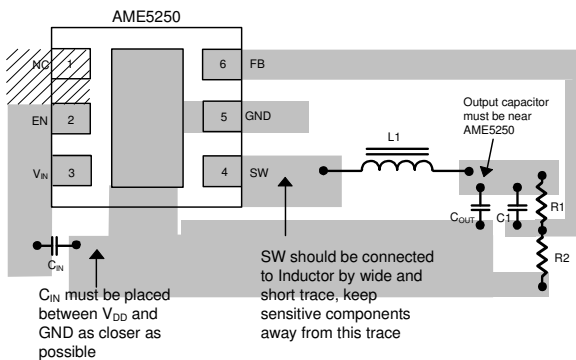
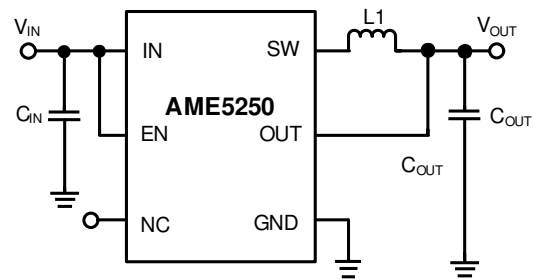
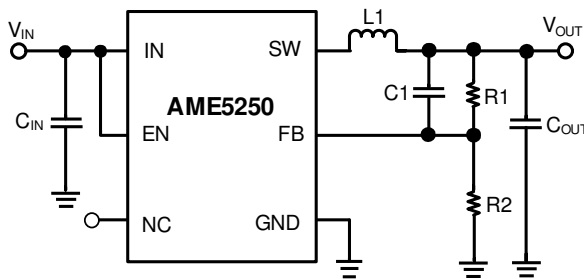

Figure 10. AME5250 Adjustable Voltage Regulator Layout Diagram

Figure 11. AME5250 Fixed Voltage Regulator Layout Diagram

■ Application Information
External components selection

| Supplier | Inductance (μ H) | Current Rating (mA) | DCR (m Ω) | Dimensions (mm) | Series |
|-------------|--------------------------|------------------------|----------------------|--------------------|----------|
| TAIYO YUDEN | 2.2 | 1480 | 60 | 3.00 x 3.00 x 1.50 | NR 3015 |
| GOTREND | 2.2 | 1500 | 58 | 3.85 x 3.85 x 1.80 | GTSD32 |
| Sumida | 2.2 | 1500 | 75 | 4.50 x 3.20 x 1.55 | CDRH2D14 |
| Sumida | 4.7 | 1000 | 135 | 4.50 x 3.20 x 1.55 | CDRH2D14 |
| TAIYO YUDEN | 4.7 | 1020 | 120 | 3.00 x 3.00 x 1.50 | NR 3015 |
| GOTREND | 4.7 | 1100 | 146 | 3.85 x 3.85 x 1.80 | GTSD32 |

Table 1. Recommended Inductors

| Supplier | Capacitance (μ H) | Package | Part Number |
|-------------|---------------------------|---------|-------------------|
| TDK | 4.7 | 603 | C1608JB0J475M |
| MURATA | 4.7 | 603 | GRM188R60J475KE19 |
| TAIYO YUDEN | 4.7 | 603 | JMK107BJ475RA |
| TAIYO YUDEN | 10 | 603 | JMK107BJ106MA |
| TDK | 10 | 805 | C2012JB0J106M |
| MURATA | 10 | 805 | GRM219R60J106ME19 |
| MURATA | 10 | 805 | GRM219R60J106KE19 |
| TAIYO YUDEN | 10 | 805 | JMK212BJ106RD |

Table 2. Recommended Capacitors for C_{IN} and C_{OUT}

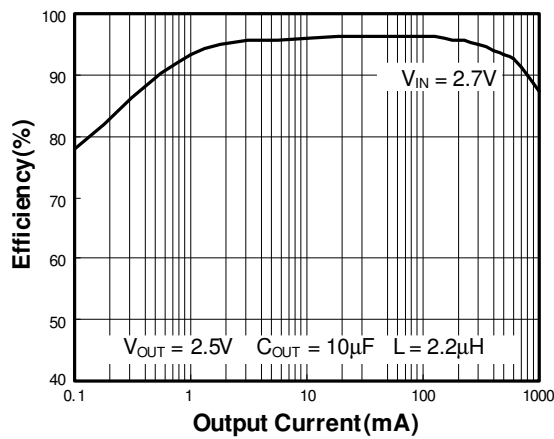
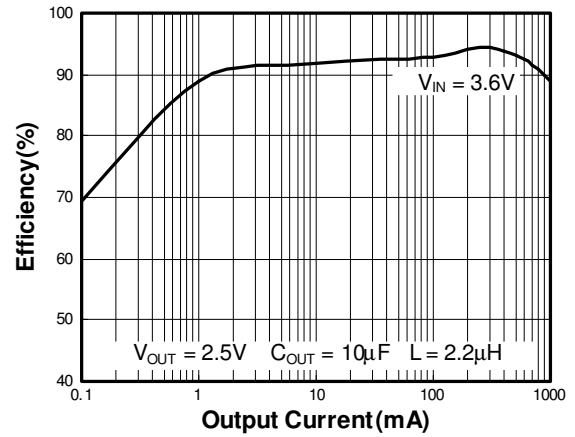
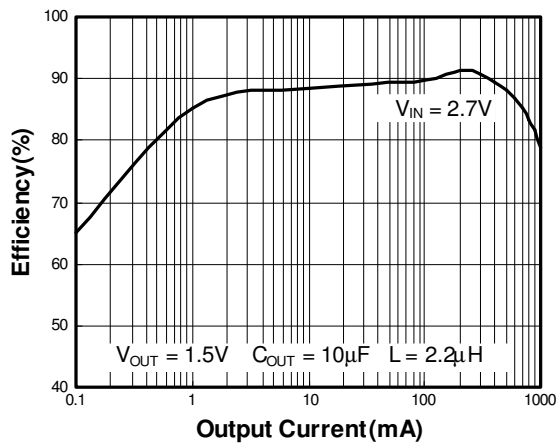
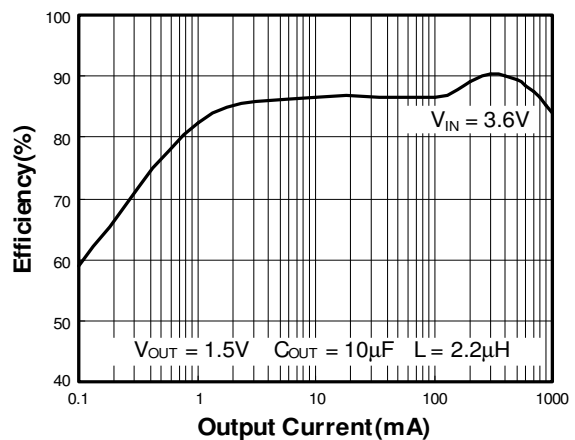
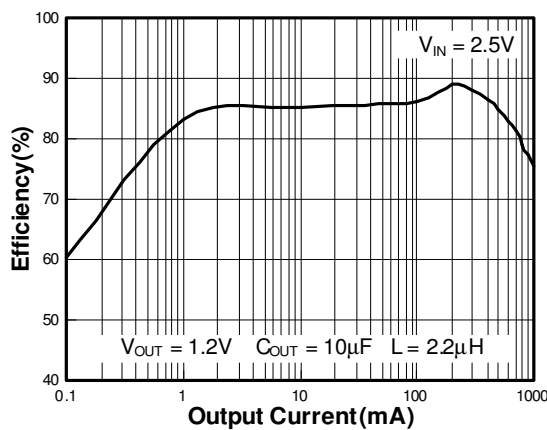
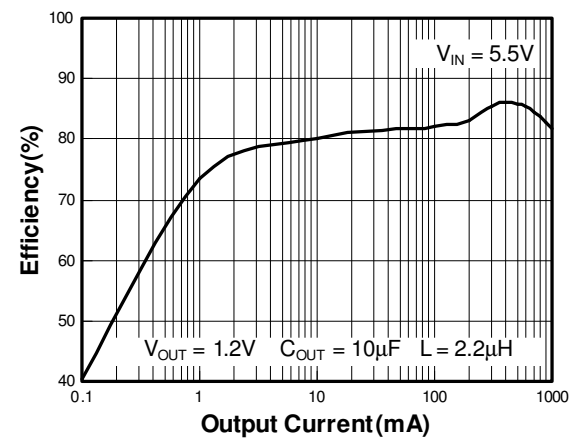
■ Characterization Curve
Efficiency vs. Output Current

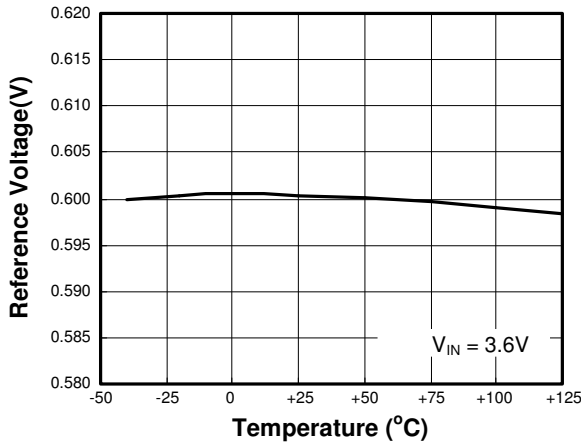
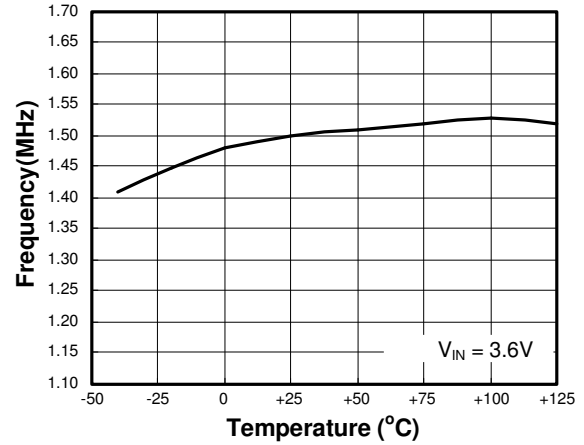
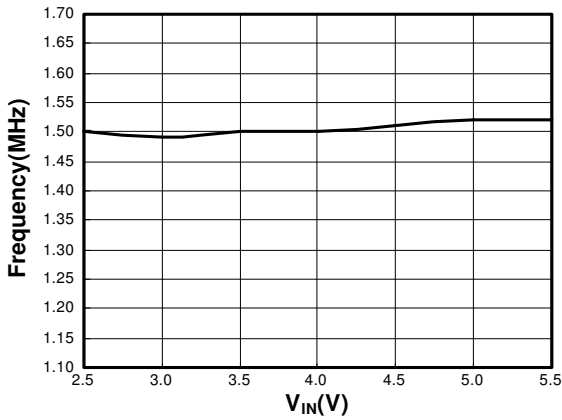
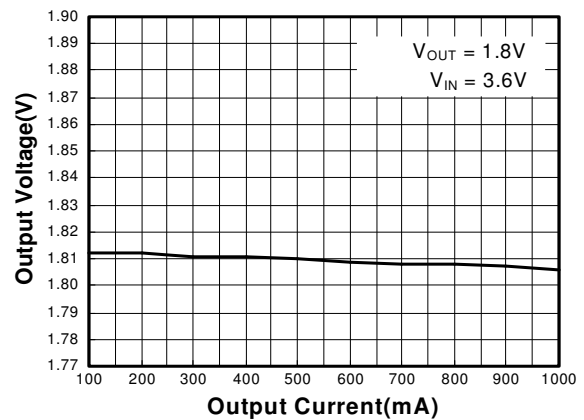
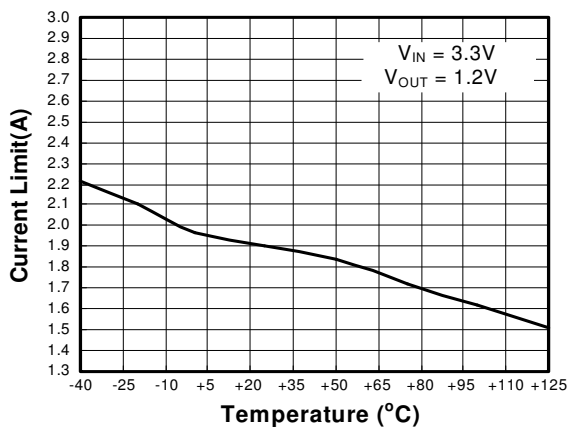
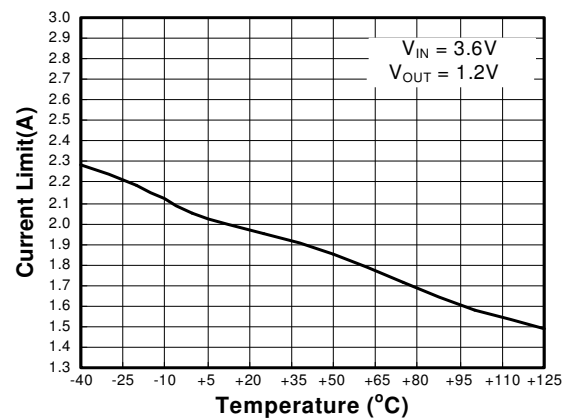
Efficiency vs. Output Current

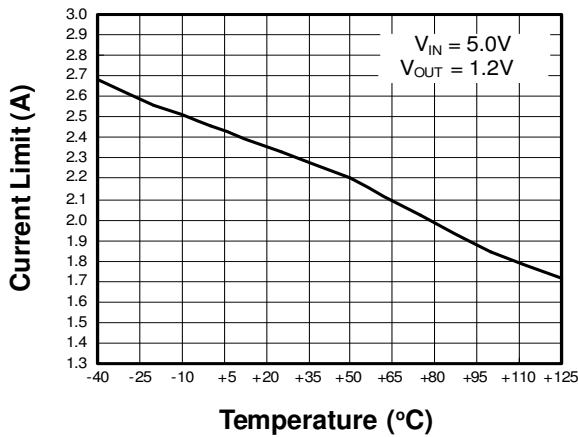
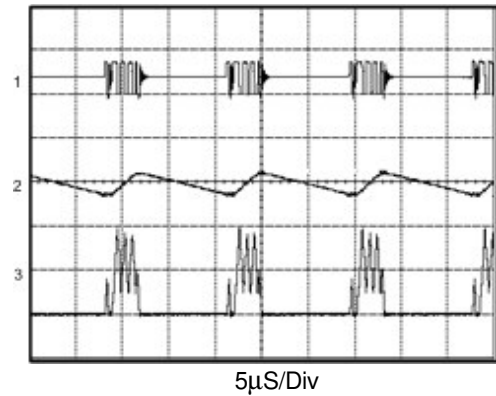
Efficiency vs. Output Current

Efficiency vs. Output Current

Efficiency vs. Output Current

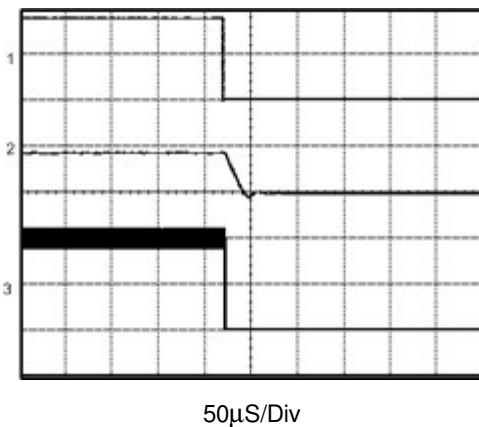
Efficiency vs. Output Current

■ Characterization Curve (Contd.)
Reference Voltage vs. Temperature

Frequency vs. Temperature

Frequency vs. Supply Voltage

Output Voltage vs. Output Current

Current Limit vs. Temperature

Current Limit vs. Temperature

■ Characterization Curve (Contd.)
Current Limit vs. Temperature

**Light Load Mode
Output Voltage Ripple**

$V_{IN} = 3.6V$
 $V_{OUT} = 1.8V$
 $I_{OUT} = 50mA$

- 1) $V_{SW} = 5V/Div$
- 2) $V_{OUT} = 100mV/Div$
- 3) $I_L = 200mA/Div$

Power Off from EN

$V_{IN} = 3.6V$
 $V_{OUT} = 1.8V$
 $I_{OUT} = 1A$

- 1) $EN = 2V/Div$
- 2) $V_{OUT} = 2V/Div$
- 3) $I_L = 500mA/Div$

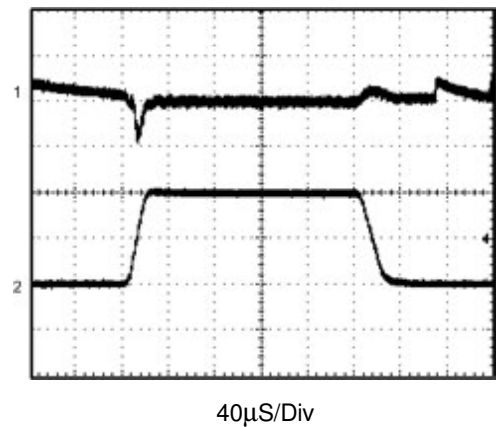
Load Step

$V_{IN} = 3.6V$
 $V_{OUT} = 1.8V$
 $I_{OUT} = 0A \sim 1A \sim 0A$

- 1) $V_{OUT} = 100mV/Div$
- 2) $I_{OUT} = 500mA/Div$

■ Characterization Curve (Contd.)
Load Step

 $40\mu\text{S}/\text{Div}$

$V_{\text{IN}} = 3.6\text{V}$
 $V_{\text{OUT}} = 1.8\text{V}$
 $I_{\text{OUT}} = 50\text{mA} \sim 1\text{A} \sim 50\text{mA}$

1) $V_{\text{OUT}} = 100\text{mV}/\text{Div}$
 2) $I_{\text{OUT}} = 500\text{mA}/\text{Div}$

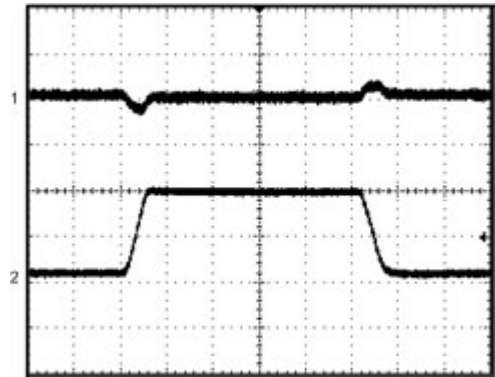
Load Step

 $40\mu\text{S}/\text{Div}$

$V_{\text{IN}} = 3.6\text{V}$
 $V_{\text{OUT}} = 1.8\text{V}$
 $I_{\text{OUT}} = 100\text{mA} \sim 1\text{A} \sim 100\text{mA}$

1) $V_{\text{OUT}} = 100\text{mV}/\text{Div}$
 2) $I_{\text{OUT}} = 500\text{mA}/\text{Div}$

Load Step

 $40\mu\text{S}/\text{Div}$

$V_{\text{IN}} = 3.6\text{V}$
 $V_{\text{OUT}} = 1.8\text{V}$
 $I_{\text{OUT}} = 200\text{mA} \sim 1\text{A} \sim 200\text{mA}$

1) $V_{\text{OUT}} = 100\text{mV}/\text{Div}$
 2) $I_{\text{OUT}} = 500\text{mA}/\text{Div}$

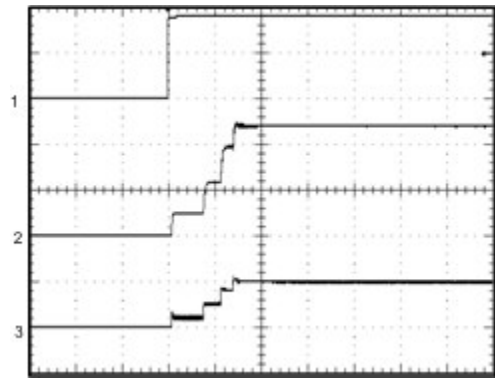
Power On from EN

 $400\mu\text{S}/\text{Div}$

$V_{\text{OUT}} = 1.2\text{V}$
 $I_{\text{OUT}} = 1\text{A}$

1) $\text{EN} = 2\text{V}/\text{Div}$
 2) $V_{\text{OUT}} = 500\text{mV}/\text{Div}$
 3) $I_{\text{L}} = 1\text{A}/\text{Div}$

■ Date Code Rule

| Month Code | |
|-------------|--------------|
| 1: January | 7: July |
| 2: February | 8: August |
| 3: March | 9: September |
| 4: April | A: October |
| 5: May | B: November |
| 6: June | C: December |

| Marking | | | | | | Year |
|---------|---|----------|----------|----------|----------|------|
| A | A | A | M | X | X | xxx0 |
| A | A | A | M | X | <u>X</u> | xxx1 |
| A | A | A | M | <u>X</u> | X | xxx2 |
| A | A | A | M | <u>X</u> | <u>X</u> | xxx3 |
| A | A | A | <u>M</u> | X | X | xxx4 |
| A | A | A | <u>M</u> | X | <u>X</u> | xxx5 |
| A | A | A | <u>M</u> | <u>X</u> | X | xxx6 |
| A | A | A | <u>M</u> | <u>X</u> | <u>X</u> | xxx7 |
| A | A | <u>A</u> | M | X | X | xxx8 |
| A | A | <u>A</u> | M | X | <u>X</u> | xxx9 |

■ Tape and Reel Dimension

DFN-6D
(2mmx2mmx0.75mm)

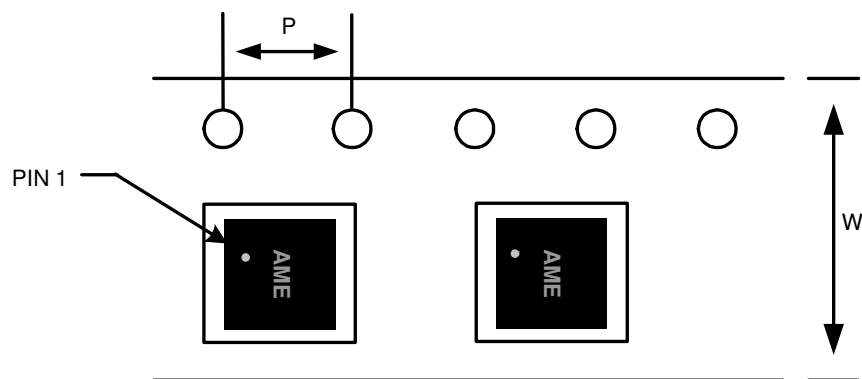

Carrier Tape, Number of Components Per Reel and Reel Size

| Package | Carrier Width (W) | Pitch (P) | Part Per Full Reel | Reel Size |
|------------------------|-------------------|------------|--------------------|-----------|
| DFN-6D (2x2x0.75mm) | 8.0±0.1 mm | 4.0±0.1 mm | 3000pcs | 180±1 mm |

AME5250
■ Tape and Reel Dimension

QFN-16C
(3mmx3mmx0.75mm)

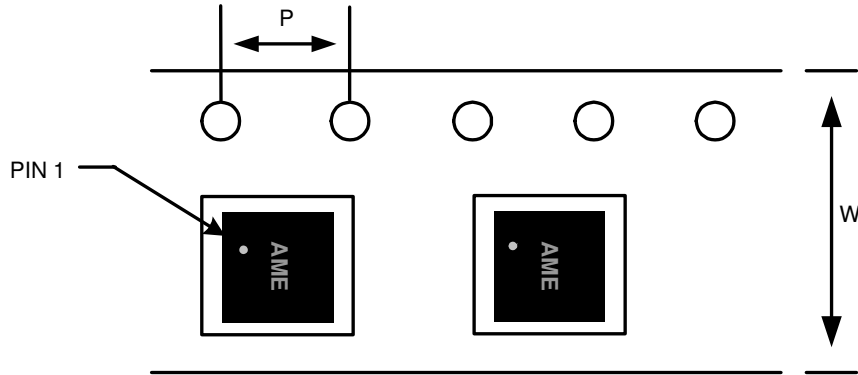

Carrier Tape, Number of Components Per Reel and Reel Size

| Package | Carrier Width (W) | Pitch (P) | Part Per Full Reel | Reel Size |
|-------------------------|-------------------|------------|--------------------|-----------|
| QFN-16C (3x3x0.75mm) | 12.0±0.1 mm | 4.0±0.1 mm | 3000pcs | 330±1 mm |

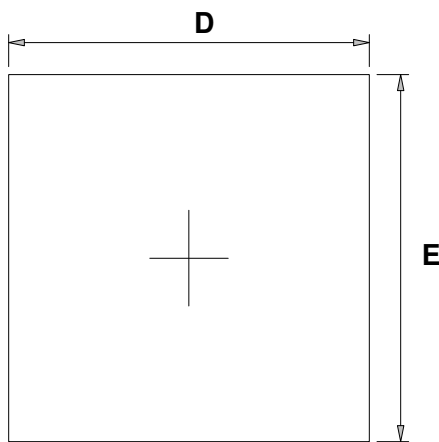
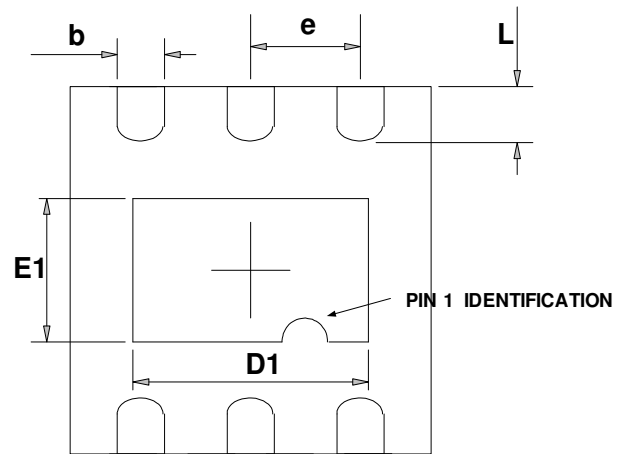
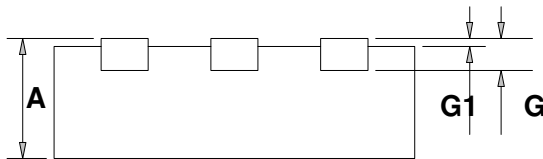
■ Package Dimension
DFN-6D
(2mmx2mmx0.75mm)

TOP VIEW

BOTTOM VIEW

REAR VIEW

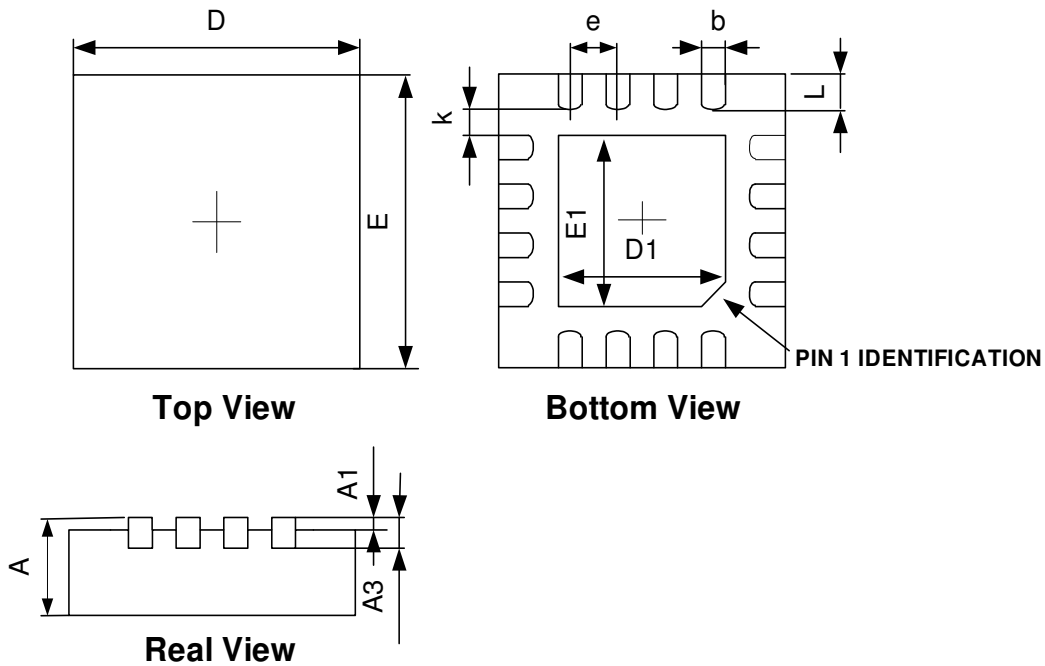
| SYMBOLS | MILLIMETERS | | INCHES | |
|-----------|-------------|-------|-----------|-------|
| | MIN | MAX | MIN | MAX |
| A | 0.700 | 0.800 | 0.028 | 0.031 |
| D | 1.900 | 2.100 | 0.075 | 0.083 |
| E | 1.900 | 2.100 | 0.075 | 0.083 |
| e | 0.650 TYP | | 0.026 TYP | |
| D1 | 1.100 | 1.650 | 0.043 | 0.065 |
| E1 | 0.600 | 1.050 | 0.024 | 0.041 |
| b | 0.180 | 0.350 | 0.007 | 0.014 |
| L | 0.200 | 0.450 | 0.008 | 0.018 |
| G | 0.178 | 0.228 | 0.007 | 0.009 |
| G1 | 0.000 | 0.050 | 0.000 | 0.002 |

■ Package Dimension

QFN-16C
(3mmx3mmx0.75mm)



| SYMBOLS | MILLIMETERS | | INCHES | |
|-----------|-------------|-------|-----------|-------|
| | MIN | MAX | MIN | MAX |
| A | 0.700 | 0.800 | 0.028 | 0.031 |
| A1 | 0.000 | 0.050 | 0.000 | 0.002 |
| A3 | 0.203REF. | | 0.008REF. | |
| D | 2.924 | 3.076 | 0.115 | 0.121 |
| E | 2.924 | 3.076 | 0.115 | 0.121 |
| D1 | 1.600 | 1.800 | 0.063 | 0.071 |
| E1 | 1.600 | 1.800 | 0.063 | 0.071 |
| k | 0.200MIN. | | 0.008MIN. | |
| b | 0.180 | 0.280 | 0.007 | 0.011 |
| e | 0.500TYP. | | 0.020TYP. | |
| L | 0.324 | 0.476 | 0.013 | 0.019 |



www.ame.com.tw
E-Mail: sales@ame.com.tw

Life Support Policy:

These products of AME, Inc. are not authorized for use as critical components in life-support devices or systems, without the express written approval of the president of AME, Inc.

AME, Inc. reserves the right to make changes in the circuitry and specifications of its devices and advises its customers to obtain the latest version of relevant information.

© AME, Inc. , January 2014
Document: 1283-DS5250-B.04

Corporate Headquarter
AME, Inc.

2F, 302 Rui-Guang Road, Nei-Hu District
Taipei 114, Taiwan.
Tel: 886 2 2627-8687
Fax: 886 2 2659-2989