

USB-Serial Dual Channel (UART/I²C/SPI) Bridge with CapSense[®] and BCD

Features

- USB 2.0 certified, Full-Speed (12 Mbps)
 - Support for communication driver class (CDC), personal health care device class (PHDC), and vendor specific drivers
 - Battery charger detection (BCD) compliant with USB Battery Charging Specification Rev 1.2 (Peripheral Detect only)
 - Integrated USB termination resistors
- Two-channel configurable UART interfaces
 - Data rates up to 3 Mbps
 - 256 bytes each transmit and receive buffer per channel
 - Data format:]
 - 7 to 8 data bits
 - 1 to 2 stop bits
 - No parity, even, odd, mark, or space parity
 - Supports parity, overrun, and framing errors
 - Supports flow control using CTS, RTS, DTR, DSR
- Two-channel configurable SPI interfaces
 - Master/slave up to 3 MHz
 - Data width: 4 bits to 16 bits
 - 256 bytes for each transmit and receive buffer per channel
 - Supports Motorola, TI, and National SPI modes
- Two-channel configurable I²C interfaces
 - Master/slave up to 400 kHz
 - Supports multi-master I²C
 - 256 bytes for each transmit and receive buffer per channel
- CapSense[®]
 - SmartSense™ Auto-Tuning is supported through a Cypress-supplied configuration utility
 - Max CapSense buttons: 8
 - GPIOs linked to CapSense buttons
- JTAG interface: JTAG master for code flashing at 400 kHz
- General-purpose input/output (GPIO) pins: 17
- Configuration utility (Windows) to configure the following:
 - Vendor ID (VID), Product ID (PID), and Product and Manufacturer descriptors
 - UART/I²C/SPI/JTAG
 - CapSense
 - Charger detection
 - GPIO

- Driver support for VCOM and DLL
 - Windows 8: 32- and 64-bit versions
 - Windows 7: 32- and 64-bit versions
 - Windows Vista: 32- and 64-bit versions
 - Windows XP: 32- and 64-bit versions
 - Windows CE
 - Mac OS-X: 10.6, 10.7
 - Linux: Kernel version 2.6.35 onwards
 - Android: Gingerbread and later versions
- Clocking: Integrated 48-MHz clock oscillator
- Supports bus-/self-powered configurations
- USB suspend mode for low power
- Operating voltage: 1.71 to 5.5 V
- Operating temperature: -40 °C to 85 °C
- ESD protection: 2.2 kV HBM
- RoHS compliant package
 - 32-pin QFN (5 × 5 × 1 mm, 0.5 mm pitch)
- Ordering part number
 - CY7C65215-32LTXI

Applications

- Medical/healthcare devices
- Point-of-Sale (POS) terminals
- Test and measurement system
- Gaming systems
- Set-top box PC-USB interface
- Industrial
- Networking
- Enabling USB connectivity in legacy peripherals

USB Compliant

The USB-Serial Dual-Channel Bridge with CapSense and BCD (CY7C65215) is fully compliant with the USB 2.0 specification and Battery Charging Specification v1.2, USB-IF Test-ID (TID) 40001521.



Contents

Block Diagram	3	Pin Description	13
Functional Overview	3	USB Power Configurations	16
USB and Charger Detect	3	USB Bus-Powered Configuration	16
Serial Communication	3	Self Powered Configuration	17
CapSense	4	USB Bus Powered with Variable I/O Voltage	18
JTAG Interface	4	Application Examples	19
GPIO Interface	4	USB-to-Dual UART Bridge	
Memory	4	with Battery-Charge Detection	19
System Resources	4	CapSense	21
Suspend and Resume	4	USB-to-Dual Channel (I2C/SPI) Bridge	22
WAKEUP	5	Ordering Information	27
Software	5	Ordering Code Definitions	27
Internal Flash Configuration	6	Package Information	28
Electrical Specifications	7	Acronyms	29
Absolute Maximum Ratings	7	Document Conventions	29
Operating Conditions	7	Units of Measure	29
Device Level Specifications	7	Document History Page	30
GPIO	8	Sales, Solutions, and Legal Information	31
nXRES	9	Worldwide Sales and Design Support	31
SPI Specifications	10	Products	31
I2C Specifications	12	PSoC® Solutions	31
JTAG Specifications	12	Cypress Developer Community	31
CapSense Specifications	12	Technical Support	31
Flash Memory Specifications	12		

Block Diagram

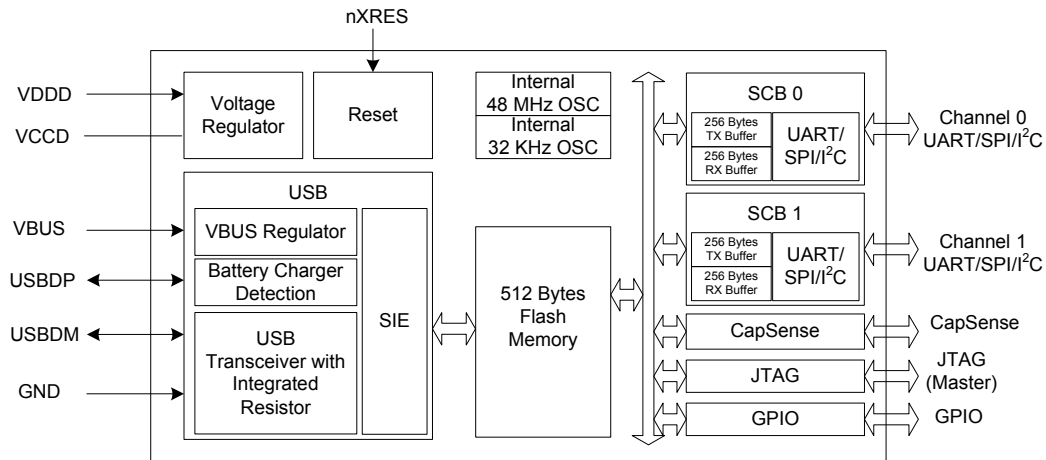

Functional Overview

The CY7C65215 is a Full-Speed USB controller that enables seamless PC connectivity for peripherals with dual-channel serial interfaces such as UART, SPI, and I²C. CY7C65215 also integrates CapSense and BCD, which is compliant with the USB Battery Charging Specification Rev. 1.2. It integrates a voltage regulator, oscillator, and flash memory for storing configuration parameters, offering a cost-effective solution. CY7C65215 supports bus-powered and self-powered modes, and enables efficient system power management with suspend and remote wake-up signals. It is available in a 32-pin QFN package.

USB and Charger Detect

USB

CY7C65215 has a built-in USB 2.0 Full-Speed transceiver. The transceiver incorporates the internal USB series termination resistors on the USB data lines and a 1.5-kΩ pull-up resistor on USBDP.

Charger Detection

CY7C65215 supports BCD for Peripheral Detect only and complies with the USB Battery Charging Specification Rev. 1.2. It supports the following charging ports:

- Standard Downstream Port (SDP): allows the system to draw up to 500 mA current from the host
- Charging Downstream Port (CDP): allows the system to draw up to 1.5 A current from the host
- Dedicated Charging Port (DCP): allows the system to draw up to 1.5 A of current from the wall charger

Serial Communication

CY7C65215 has two serial communication blocks (SCBs). Each SCB can implement UART, SPI, or an I²C interface. A 256-byte buffer is available in both the TX and RX lines.

UART Interface

The UART interface provides asynchronous serial communication with other UART devices operating at speeds of up to 3 Mbps. It supports 7 to 8 data bits, 1 to 2 stop bits, odd, even, mark, space, and no parity. The UART interface supports full duplex communication with a signaling format that is compatible with the standard UART protocol. The UART pins may be interfaced to industry-standard RS-232 transceivers to manage different voltage levels.

CY7C65215 supports common UART functions such as parity error and frame error. In addition, CY7C65215 supports baud rates ranging from 300 baud to 3 Mbaud. UART baud rates can be set using the configuration utility.

UART Flow Control

The CY7C65215 device supports UART hardware flow control using control signal pairs such as RTS# (Request to Send) / CTS# (Clear to Send) and DTR# (Data Terminal Ready) / DSR# (Data Set Ready). Data flow control is enabled by default. Flow control can be disabled using the configuration utility.

The following section describes the flow control signals:

■ CTS# (Input) / RTS# (Output)

CTS# can pause or resume data transmission over the UART interface. Data transmission can be paused by de-asserting the CTS signal and resumed with CTS# assertion. The pause and resume operation does not affect data integrity. The receive buffer has a watermark level of 80%. After the data in the receive buffer reaches that level, the RTS# signal is de-asserted, instructing the transmitting device to stop data transmission. The start of data consumption by the application reduces device data backlog. When it reaches the 50% watermark level, the RTS# signal is asserted to resume data reception.

■ DSR# (Input) /DTR# (Output)

DSR#/DTR# signals are used to establish the communication link with the UART. These signals complement each other in their functionality, similar to CTS# and RTS#.

SPI Interface

The SPI interface supports SPI Master and SPI Slave. This interface supports the Motorola, TI, and National Microwire protocols. The maximum frequency of operation is 3 MHz in the Master and Slave modes. It can support transaction sizes ranging from 4 bits to 16 bits in length (for more details, refer to [USB-to-Dual Channel \(I2C/SPI\) Bridge on page 22](#)).

I²C Interface

The I²C interface implements full multi-master/slave modes and supports up to 400 kHz. The configuration utility tool is used to set the I²C address in slave mode. This tool enables only even slave addresses. For further details on protocol, refer to the NXP I²C specification rev5.

Notes

- I²C ports are not tolerant of higher voltages and cannot be hot-swapped or powered up independently from the rest of the I²C system.
- The minimum fall time is not met, as required by the NXP I²C specification rev5, except when V_{DD} = 1.71 V to 3.0 V. The minimum fall time can be met by adding a 50-pF capacitor for the V_{DD} = 3.0 V–3.6 V range.

CapSense

CapSense functionality is supported on all the GPIO pins. Any GPIO pin can be configured as a sense pin (CS0–CS7) using the configuration utility. When implementing CapSense functionality, the GPIO_0 pin (configured as the modulator capacitor - Cmod) should be connected to ground through a 2.2-nF capacitor (see [Figure 10 on page 21](#)). CY7C65215 supports SmartSense auto-tuning of CapSense parameters and does not require manual tuning. SmartSense auto-tuning compensates for printed circuit board (PCB) variations and device process variations.

Optionally, any GPIO pin can be configured as a Cshield and connected to the shield of the CapSense button as shown in [Figure 10 on page 21](#). The shield prevents false triggering of buttons due to water droplets and guarantees CapSense operation (sensors respond to finger touch). GPIOs can be linked to CapSense buttons to indicate the presence of a finger. CapSense functionality can be configured using configuration utility.

CY7C65215 supports up to eight CapSense buttons. For more information on CapSense, refer to [Getting Started with CapSense](#).

JTAG Interface

CY7C65215 supports a 5-pin JTAG in master mode for code flashing at 400 kHz.

GPIO Interface

CY7C65215 has 17 GPIOs. A maximum of 17 GPIOs are available for configuration if one 2-pin (I²C/2-pin UART) serial interface is implemented. The configuration utility allows configuration of the GPIO pins. The configurable options are as follows:

- TRISTATE: GPIO tristated
- DRIVE 1: Output static 1

- DRIVE 0: Output static 0
- POWER#: Power control for bus power designs
- TXLED#: Drives LED during USB transmit
- RXLED#: Drives LED during USB receive
- TX or RX LED#: Drives LED during USB transmit or receive
GPIO can be configured to drive LED at 8-mA drive strength.
- BCD0/BCD1: Two-pin output to indicate the type of USB charger
- BUSDETECT: Connects VBUS pin for USB host detection
- CS0–CS7: CapSense button input (Sense pin)
- CSout0–CSout3: Indicates which CapSense button is pressed
- Cmod: External modulator capacitor that connects a 2.2-nF capacitor (±10%) to ground (GPIO_0 only)
- Cshield: Shield for waterproofing

Memory

CY7C65215 has a 512-byte flash. The flash is used to store the USB parameters such as VID/PID, serial number, Product, and Manufacturer Descriptors, which can be programmed by the configuration utility.

System Resources

Power System

CY7C65215 supports the USB Suspend mode to control power usage. CY7C65215 operates in bus-powered or self-powered modes over a range of 3.15 to 5.25 V.

Clock System

CY7C65215 has a fully integrated clock and does not require any external components. The clock system is responsible for providing clocks to all subsystems.

Internal 48-MHz Oscillator

The internal 48-MHz oscillator is the primary source of internal clocking in CY7C65215.

Internal 32-kHz Oscillator

The internal 32-kHz oscillator is low power and relatively inaccurate. It is primarily used to generate clocks for peripheral operation in the USB Suspend mode.

Reset

The reset block ensures reliable power-on reset or reconfiguration to a known state. The nXRES (active low) pin can be used by external devices to reset the CY7C65215.

Suspend and Resume

The CY7C65215 device asserts the SUSPEND pin when the USB bus enters the suspend state. This helps in meeting the stringent suspend current requirement of the USB 2.0 specification, while using the device in bus-powered mode. The device will resume from the suspend state under any of the following conditions:

1. Any activity is detected on the USB bus

2. The WAKEUP pin is asserted to generate remote wakeup to the host

WAKEUP

The WAKEUP pin is used to generate a remote wakeup signal on the USB bus. The remote wakeup signal is sent only if the host enables this feature through the SET_FEATURE request. The device communicates support for the remote wakeup to the host through the configuration descriptor during the USB enumeration process. The CY7C65215 device allows enabling/disabling and polarity of the remote wakeup feature through the configuration utility.

Software

Cypress delivers a complete set of software drivers and the configuration utility to enable product configuration during system development.

Drivers for Linux Operating Systems

Cypress provides a User Mode USB driver library (*libcyusb-serial.so*) that abstracts vendor commands for the UART interface and provides a simplified API interface to the user applications. This library makes use of the standard open source libUSB library to enable the USB communication. The Cypress serial library supports the USB plug-and-play feature using the Linux 'udev' mechanism.

CY7C65215 supports the standard USB CDC UART class driver, which is bundled with the Linux kernel.

Android Support

The CY7C65215 solution includes an Android Java class—*CyUsbSerial.java*—which exposes a set of interface functions to communicate with the device.

Drivers for Mac OSx

Cypress delivers a dynamically linked shared library (*CyUSB-Serial.dylib*) based on libUSB, which enables communication to the CY7C65215 device.

In addition, the device also supports the native Mac OSx CDC UART-class driver.

Drivers for Windows Operating Systems

For Windows operating systems (XP, Vista, Win7, and Win8), Cypress delivers a User Mode dynamically linked

library—*CyUSBSerial DLL*—that abstracts vendor-specific interface of CY7C65215 devices and provides convenient APIs to the user. It provides interface APIs for vendor-specific UART and class-specific APIs for PHDC.

A virtual COM port driver – *CyUSBSerial.sys* – is also delivered, which implements the USB CDC class driver. The Cypress Windows drivers are:

- Windows Driver Foundation (WDF) compliant
- Compatible with any USB 2.0-compliant device
- Compatible with Cypress USB 3.0-compliant devices

They also support Windows plug-and-play and power management and USB Remote Wake-up

CY7C65215 also works with the Windows-standard USB CDC UART class driver.

Windows-CE support

The CY7C65215 solution also includes a dynamically linked library (DLL) and CDC UART driver library for Windows-CE platforms.

Device Configuration Utility (Windows Only)

A Windows-based configuration utility is available to configure various device initialization parameters. This graphical user application provides an interactive interface to define the various boot parameters stored in the device flash.

This utility allows the user to save a user-selected configuration to text or xml formats. It also allows users to load a selected configuration from text or xml formats. The configuration utility allows the following operations:

- View current device configuration
- Select and configure UART/I2C/SPI, CapSense, battery charging, and GPIOs
- Configure USB VID, PID, and string descriptors
- Save or Load configuration

You can download the free configuration utility and drivers from www.cypress.com.

Internal Flash Configuration

The internal flash memory can be used to store the configuration parameters shown in the following table. A free configuration utility is provided to configure the parameters listed in the table to meet application specific requirements over USB interface. The configuration utility can be downloaded from www.cypress.com.

Table 1. Internal Flash Configuration

Parameter	Default Value	Description
USB Configuration		
USB Vendor ID (VID)	0x04B4	Default Cypress VID. Can be configured to customer VID
USB Product ID (PID)	0x0005	Default Cypress PID. Can be configured to customer PID
Manufacturer string	Cypress	Can be configured with any string up to 64 characters
Product string	USB-Serial (Dual Channel)	Can be configured with any string up to 64 characters
Serial string		Can be configured with any string up to 64 characters
Power mode	Bus powered	Can be configured to bus-powered or self-powered mode
Max current draw	100 mA	Can be configured to any value from 0 to 500 mA. Based on this, the configuration descriptor will be updated.
Remote wakeup	Enabled	Can be disabled. Remote wakeup is initiated by asserting WAKEUP pin
USB interface protocol	CDC	Can be configured to function in CDC, PHDC, or Cypress vendor class
BCD	Disabled	Charger detect is disabled by default. When BCD is enabled, three of the GPIOs must be configured for BCD
GPIO Configuration		
GPIO_0	TXLED#	GPIO can be configured as shown in Table 16 on page 15 .
GPIO_1	RXLED#	
GPIO_2	DSR#_0	
GPIO_3	RTS#_0	
GPIO_4	CTS#_0	
GPIO_5	TxD_0	
GPIO_6	POWER#	
GPIO_7	TRISTATE	
GPIO_8	RxD_0	
GPIO_9	DTR#_0	
GPIO_10	RxD_1	
GPIO_11	TxD_1	
GPIO_12	RTS#_1	
GPIO_13	CTS#1	
GPIO_14	DSR#_1	
GPIO_15	DTR#_1	
GPIO_16	TRISTATE	
GPIO_17	TRISTATE	
GPIO_18	TRISTATE	

Electrical Specifications

Absolute Maximum Ratings

Exceeding maximum ratings ^[1] may shorten the useful life of the device.

Storage temperature	-55 °C to +100 °C
Ambient temperature with power supplied (Industrial)	-40 °C to +85 °C
Supply voltage to ground potential	
V _{DDD}	6.0 V
V _{BUS}	6.0 V
V _{CCD}	1.95 V
V _{GPIO}	V _{DDD} + 0.5

Static discharge voltage ESD protection levels:

■ 2.2-kV HBM per JESD22-A114

Latch-up current 140 mA

Current per GPIO 25 mA

Operating Conditions

T_A (ambient temperature under bias)

Industrial -40 °C to +85 °C

V_{BUS} supply voltage 3.15 V to 5.25 V

V_{DDD} supply voltage 1.71 V to 5.50 V

V_{CCD} supply voltage 1.71 V to 1.89 V

Device Level Specifications

All specifications are valid for -40 °C ≤ T_A ≤ 85 °C, T_J ≤ 100 °C, and 1.71 V to 5.50 V, except where noted.

Table 2. DC Specifications

Parameter	Description	Min	Typ	Max	Units	Details/Conditions
V _{BUS}	V _{BUS} supply voltage	3.15	3.30	3.45	V	Set and configure correct voltage range using the configuration utility for V _{BUS} . Default 5 V.
		4.35	5.00	5.25	V	
V _{DDD}	V _{DDD} supply voltage	1.71	1.80	1.89	V	Used to set I/O and core voltage. Set and configure correct voltage range using the configuration utility for V _{DDD} . Default 3.3 V.
		2.0	3.3	5.5	V	
V _{CCD}	Output voltage (for core logic)	-	1.80	-	V	Do not use this supply to drive external device. <ul style="list-style-type: none"> 1.71 V ≤ V_{DDD} ≤ 1.89 V: Short the V_{CCD} pin with the V_{DDD} pin V_{DDD} > 2 V – connect a 1-μF capacitor (C_{efc}) between the V_{CCD} pin and ground
C _{efc}	External regulator voltage bypass	1.00	1.30	1.60	μF	X5R ceramic or better
I _{DD1}	Operating supply current	-	20	-	mA	USB 2.0 FS, UART at 1 Mbps single channel, no GPIO switching
I _{DD2}	USB Suspend supply current	-	5	-	μA	Does not include current through a pull-up resistor on USB _{DP}

Table 3. AC Specifications

Parameter	Description	Min	Typ	Max	Units	Details/Conditions
F1	Frequency	47.04	48	48.96	Mhz	Non-USB mode
F2		47.88	48	48.12		USB mode
Z _{out}	USB driver output impedance	28	-	44	Ω	
T _{wakeup}	Wakeup from USB Suspend mode	-	25	-	μs	

Note

- Usage above the absolute maximum conditions may cause permanent damage to the device. Exposure to Absolute Maximum conditions for extended periods of time may affect device reliability. When used below Absolute Maximum conditions but above normal operating conditions the device may not operate to specification.

GPIO
Table 4. GPIO DC Specification

Parameter	Description	Min	Typ	Max	Units	Details/Conditions
$V_{IH}^{[2]}$	Input voltage high threshold	$0.7 \times V_{DDDD}$	–	–	V	CMOS Input
V_{IL}	Input voltage low threshold	–	–	$0.3 \times V_{DDDD}$	V	CMOS Input
$V_{IH}^{[2]}$	LVTTL input, $V_{DDDD} < 2.7$ V	$0.7 \times V_{DDDD}$	–	–	V	
V_{IL}	LVTTL input, $V_{DDDD} < 2.7$ V	–	–	$0.3 \times V_{DDDD}$	V	
$V_{IH}^{[2]}$	LVTTL input, $V_{DDDD} \geq 2.7$ V	2	–	–	V	
V_{IL}	LVTTL input, $V_{DDDD} \geq 2.7$ V	–	–	0.8	V	
V_{OH}	Output voltage high level	$V_{DDDD} - 0.4$	–	–	V	$I_{OH} = 4$ mA, $V_{DDDD} = 5$ V +/- 10%
V_{OH}	Output voltage high level	$V_{DDDD} - 0.6$	–	–	V	$I_{OH} = 4$ mA, $V_{DDDD} = 3.3$ V +/- 10%
V_{OH}	Output voltage high level	$V_{DDDD} - 0.5$	–	–	V	$I_{OH} = 1$ mA, $V_{DDDD} = 1.8$ V +/- 5%
V_{OL}	Output voltage low level	–	–	0.4	V	$I_{OL} = 8$ mA, $V_{DDDD} = 5$ V +/- 10%
V_{OL}	Output voltage low level	–	–	0.6	V	$I_{OL} = 8$ mA, $V_{DDDD} = 3.3$ V +/- 10%
V_{OL}	Output voltage low level	–	–	0.6	V	$I_{OL} = 4$ mA, $V_{DDDD} = 1.8$ V +/- 5%
Rpullup	Pull-up resistor	3.5	5.6	8.5	k Ω	
Rpulldown	Pull-down resistor	3.5	5.6	8.5	k Ω	
I_{IL}	Input leakage current (absolute value)	–	–	2	nA	25 °C, $V_{DDDD} = 3.0$ V
C_{IN}	Input capacitance	–	–	7	pF	
Vhystttl	Input hysteresis LVTTL; $V_{DDDD} > 2.7$ V	25	40	–	mV	
Vhyscmos	Input hysteresis CMOS	$0.05 \times V_{DDDD}$	–	–	mV	

Table 5. GPIO AC Specification

Parameter	Description	Min	Typ	Max	Units	Details/Conditions
$T_{RiseFast1}$	Rise Time in Fast mode	2	–	12	ns	$V_{DDDD} = 3.3$ V/ 5.5 V, Load = 25 pF
$T_{FallFast1}$	Fall Time in Fast mode	2	–	12	ns	$V_{DDDD} = 3.3$ V/ 5.5 V, Load = 25 pF
$T_{RiseSlow1}$	Rise Time in Slow mode	10	–	60	ns	$V_{DDDD} = 3.3$ V/ 5.5 V, Load = 25 pF
$T_{FallSlow1}$	Fall Time in Slow mode	10	–	60	ns	$V_{DDDD} = 3.3$ V/ 5.5 V, Load = 25 pF
$T_{RiseFast2}$	Rise Time in Fast mode	2	–	20	ns	$V_{DDDD} = 1.8$ V, Load = 25 pF
$T_{FallFast2}$	Fall Time in Fast mode	20	–	100	ns	$V_{DDDD} = 1.8$ V, Load = 25 pF
$T_{RiseSlow2}$	Rise Time in Slow mode	2	–	20	ns	$V_{DDDD} = 1.8$ V, Load = 25 pF
$T_{FallSlow2}$	Fall Time in Slow mode	20	–	100	ns	$V_{DDDD} = 1.8$ V, Load = 25 pF

Note

2. V_{IH} must not exceed $V_{DDDD} + 0.2$ V.

nXRES
Table 6. nXRES DC Specifications

Parameter	Description	Min	Typ	Max	Units	Details/Conditions
V _{IH}	Input voltage high threshold	0.7 × V _{DDD}	–	–	V	
V _{IL}	Input voltage low threshold	–	–	0.3 × V _{DDD}	V	
R _{pullup}	Pull-up resistor	3.5	5.6	8.5	kΩ	
C _{IN}	Input capacitance	–	5	–	pF	
V _{hysxres}	Input voltage hysteresis	–	100	–	mV	

Table 7. nXRES AC Specifications

Parameter	Description	Min	Typ	Max	Units	Details/Conditions
T _{resetwidth}	Reset pulse width	1	–	–	μs	

Table 8. UART AC Specifications

Parameter	Description	Min	Typ	Max	Units	Details/Conditions
F _{UART}	UART bit rate	0.3	–	3000	kbps	Single SCB: TX + RX Dual SCB: TX or RX

SPI Specifications

Figure 1. SPI Master Timing

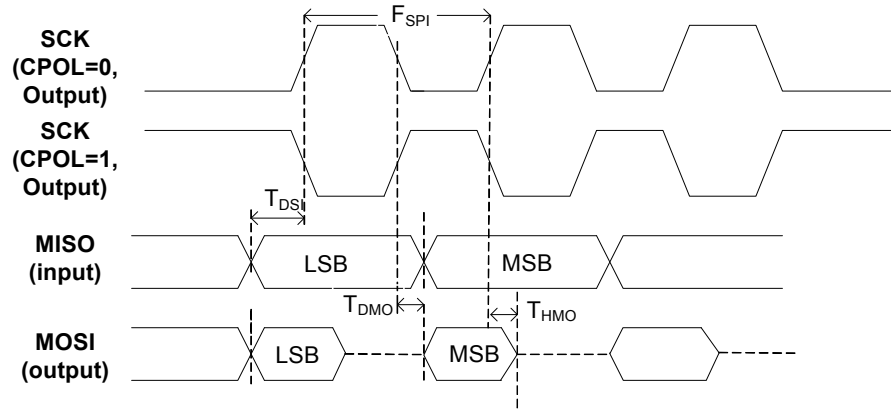

SPI Master Timing for CPHA = 0 (Refer to Table 17)

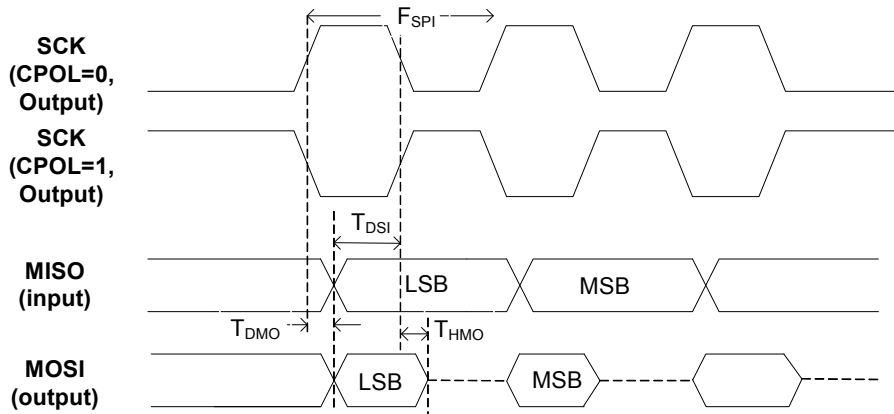

SPI Master Timing for CPHA = 1 (Refer to Table 17)

Figure 2. SPI Slave Timing

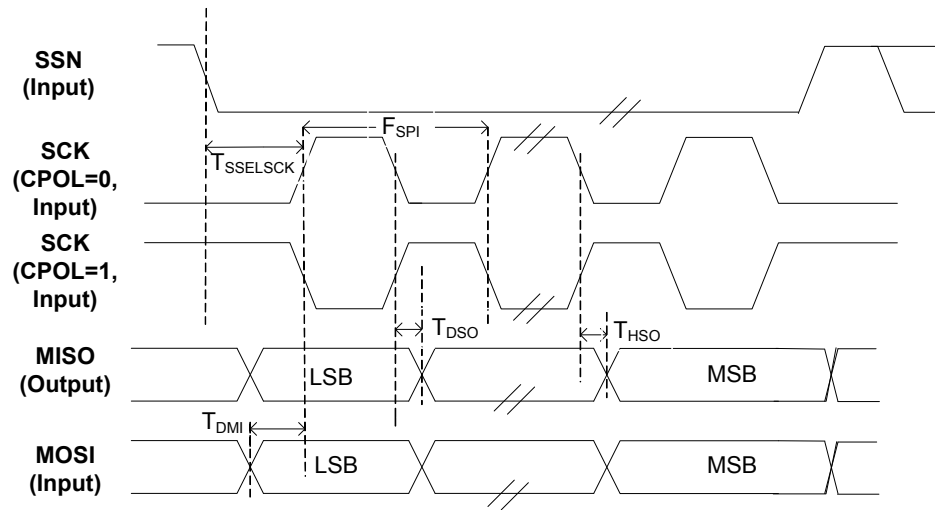

SPI Slave Timing for CPHA = 0 (Refer to Table 17)

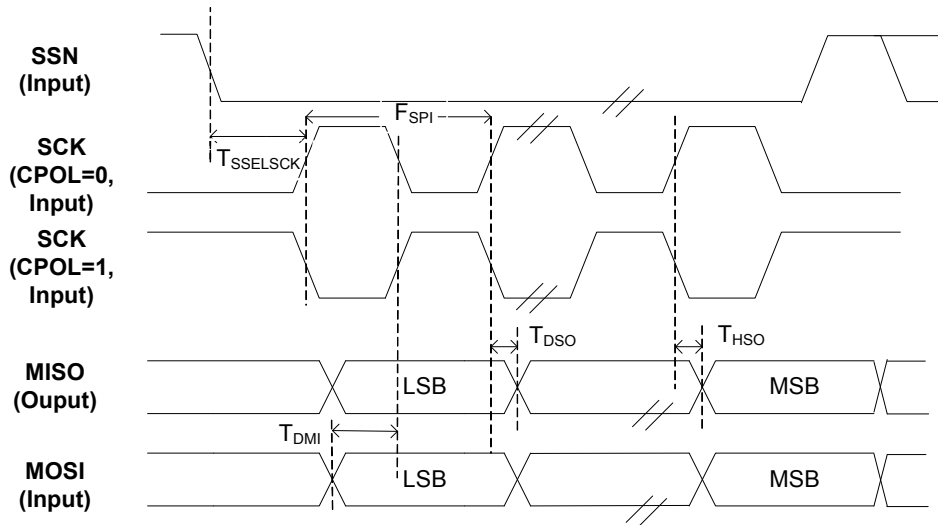

SPI Slave Timing for CPHA = 1 (Refer to Table 17)

Table 9. SPI AC Specifications

Parameter	Description	Min	Typ	Max	Units	Details/Conditions
F _{SPI}	SPI operating frequency (Master/Slave)	–	–	3	MHz	Single SCB: TX + RX Dual SCB: TX or RX
WL _{SPI}	SPI word length	4	–	16	bits	
SPI Master Mode						
T _{DMO}	MOSI valid after SClock driving edge	–	–	15	ns	
T _{DSI}	MISO valid before SClock capturing edge	20	–	–	ns	
T _{HMO}	Previous MOSI data hold time with respect to capturing edge at slave	0	–	–	ns	
SPI Slave Mode						
T _{DMI}	MOSI valid before Sclock Capturing edge	40	–	–	ns	
T _{DSO}	MISO valid after Sclock driving edge	–	–	104.4	ns	
T _{HSO}	Previous MISO data hold time	0	–	–	ns	
T _{SSELCK}	SSEL valid to first SCK valid edge	100	–	–	ns	

I²C Specifications

Table 10. I²C AC Specifications

Parameter	Description	Min	Typ	Max	Units	Details/Conditions
F _{I2C}	I ² C frequency	1	–	400	kHz	

JTAG Specifications

Table 11. JTAG AC Specifications

Parameter	Description	Min	Typ	Max	Units	Details/Conditions
F _{JTAG}	JTAG operating frequency (master)	–	–	400	kHz	Code flashing

CapSense Specifications

Table 12. CapSense AC Specifications

Parameter	Description	Min	Typ	Max	Units	Details/Conditions
V _{CSD}	Voltage range of operation	1.71	–	5.50	V	
SNR	Ratio of counts of finger to noise	5	–	–	Ratio	Sensor capacitance range of 9 to 35 pF; finger capacitance ≥ 0.1 pF sensitivity

Flash Memory Specifications

Table 13. Flash Memory Specifications

Parameter	Description	Min	Typ	Max	Units	Details/Conditions
F _{end}	Flash endurance	100 K	–	–	cycles	
F _{ret}	Flash retention. T _A ≤ 85 °C, 10 K program/erase cycles	10	–	–	years	

Pin Description

Pin ^[3]	Type	Name		Default	Description
1	Power	VDDD		–	Supply to the device core and Interface, 1.71 to 5.5 V
2	SCB/GPIO	SCB0_0	GPIO_8	RxD_0	GPIO/SCB0. See Table 14 and Table 16 on page 15
3	SCB/GPIO	SCB0_5	GPIO_9	DTR#_0	GPIO/SCB0. See Table 14 and Table 16 on page 15
4	Power	VSSD		–	Digital Ground
5	SCB/GPIO	SCB1_0	GPIO_10	RxD_1	GPIO/SCB1. See Table 15 and Table 16 on page 15
6	SCB/GPIO	SCB1_1	GPIO_11	TxD_1	GPIO/SCB1. See Table 15 and Table 16 on page 15
7	SCB/GPIO	SCB1_2	GPIO_12	RTS#_1	GPIO/SCB1. See Table 15 and Table 16 on page 15
8	SCB/GPIO	SCB1_3	GPIO_13	CTS#_1	GPIO/SCB1. See Table 15 and Table 16 on page 15
9	SCB/GPIO	SCB1_4	GPIO_14	DSR#_1	GPIO/SCB1. See Table 15 and Table 16 on page 15
10	SCB/GPIO	SCB1_5	GPIO_15	DTR#_1	GPIO/SCB1. See Table 15 and Table 16 on page 15
11	Output	SUSPEND		–	Indicates device in suspend mode. Can be configured as active low/high using configuration utility
12	Input	WAKEUP		–	Wakeup device from suspend mode. Can be configured as active low/high using configuration utility
13	GPIO	GPIO_16		TRISTATE	GPIO. See Table 16 on page 15
14	USBIO	USB DP		–	USB Data Signal Plus, integrates termination resistor and 1.5-kΩ pull up resistor
15	USBIO	USB DM		–	USB Data Signal Minus, integrates termination resistor
16	Power	VCCD		–	Regulated supply, connect to 1-μF cap or 1.8 V
17	Power	VSSD		–	Digital Ground
18	nXRES	nXRES		–	Chip reset, active low. Can be left unconnected or have a pull-up resistor connected if not used.
19	Power	VBUS		–	VBUS Supply, 3.15 V to 5.25 V
20	Power	VSSD		–	Digital Ground
21	GPIO	GPIO_17		TRISTATE	GPIO. See Table 16 on page 15
22	GPIO	GPIO_18		TRISTATE	GPIO. See Table 16 on page 15
23	Power	VDDD		–	Supply to the device core and Interface, 1.71 to 5.5 V
24	Power	VSSA		–	Analog Ground
25	GPIO	GPIO_0		TXLED#	GPIO. See Table 16 on page 15
26	GPIO	GPIO_1		RXLED#	GPIO. See Table 16 on page 15
27	SCB/GPIO	SCB0_1	GPIO_2	DSR#_0	GPIO/SCB0. See Table 14 and Table 16 on page 15
28	SCB/GPIO	SCB0_2	GPIO_3	RTS#_0	GPIO/SCB0. See Table 14 and Table 16 on page 15
29	SCB/GPIO	SCB0_3	GPIO_4	CTS#_0	GPIO/SCB0. See Table 14 and Table 16 on page 15
30	SCB/GPIO	SCB0_4	GPIO_5	TxD_0	GPIO/SCB0. See Table 14 and Table 16 on page 15
31	GPIO	GPIO_6		POWER#	GPIO. See Table 16 on page 15
32	GPIO	GPIO_7		TRISTATE	GPIO. See Table 16 on page 15

Note

3. Any pin acting as an Input pin should not be left unconnected.

Figure 3. 32-Pin QFN Pinout

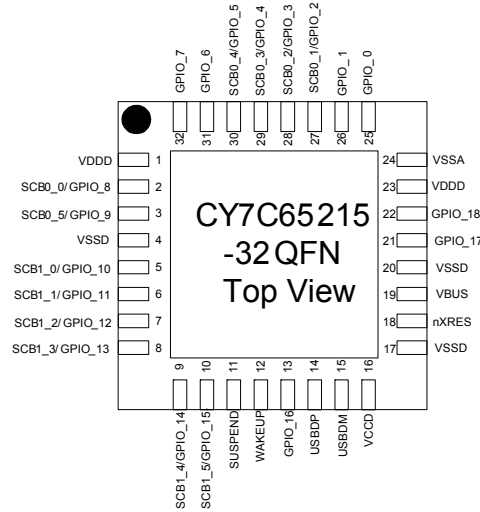

Table 14. Serial Communication Block (SCB0) Configuration

Pin	Serial Port 0	Mode 0*	Mode 1	Mode 2	Mode 3	Mode 4	Mode 5	Mode 6
		6-pin UART	4-pin UART	2-pin UART	SPI Master	SPI Slave	I ² C Master	I ² C Slave
2	SCB0_0	RxD_0	RxD_0	RxD_0	GPIO_8	GPIO_8	GPIO_8	GPIO_8
27	SCB0_1	DSR#_0	GPIO_2	GPIO_2	SSEL_OUT_0	SSEL_IN_0	GPIO_2	GPIO_2
28	SCB0_2	RTS#_0	RTS#_0	GPIO_3	MISO_IN_0	MISO_OUT_0	SCL_OUT_0	SCL_IN_0
29	SCB0_3	CTS#_0	CTS#_0	GPIO_4	MOSI_OUT_0	MOSI_IN_0	SDA_0	SDA_0
30	SCB0_4	TxD_0	TxD_0	TxD_0	SCLK_OUT_0	SCLK_IN_0	GPIO_5	GPIO_5
3	SCB0_5	DTR#_0	GPIO_9	GPIO_9	GPIO_9	GPIO_9	GPIO_9	GPIO_9

*Note: Device configured in Mode 0 as default. Other modes can be configured through Cypress-supplied configuration utility.

Table 15. Serial Communication Block (SCB1) Configuration

Pin	Serial Port 1	Mode 0*	Mode 1	Mode 2	Mode 3	Mode 4	Mode 5	Mode 6	Mode 7
		6-pin UART	4-pin UART	2-pin UART	SPI Master	SPI Slave	I ² C Master	I ² C Slave	JTAG Master
5	SCB1_0	RxD_1	RxD_1	RxD_1	MISO_IN_1	MISO_OUT_1	SCL_OUT_1	SCL_IN_1	TDI
6	SCB1_1	TxD_1	TxD_1	TxD_1	MOSI_OUT_1	MOSI_IN_1	SDA_1	SDA_1	TDO
7	SCB1_2	RTS#_1	RTS#_1	GPIO_12	SSEL_OUT_1	SSEL_IN_1	GPIO_12	GPIO_12	TMS
8	SCB1_3	CTS#_1	CTS#_1	GPIO_13	SCLK_OUT_1	SCLK_IN_1	GPIO_13	GPIO_13	TCK
9	SCB1_4	DSR#_1	GPIO_14	GPIO_14	GPIO_14	GPIO_14	GPIO_14	GPIO_14	TRST#
10	SCB1_5	DTR#_1	GPIO_15	GPIO_15	GPIO_15	GPIO_15	GPIO_15	GPIO_15	GPIO_15

*Note: Device configured in Mode 0 as default. Other modes can be configured via Cypress-supplied configuration utility.

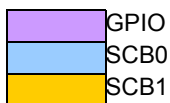

Table 16. GPIO Configuration

GPIO Configuration Option	Description
TRISTATE	I/O tristated
DRIVE 1	Output static 1
DRIVE 0	Output static 0
POWER#	This output is used to control power to an external logic via switch to cut power off during unconfigured USB device and USB suspend. 0 - USB device in Configured state 1 - USB device in Unconfigured state or during USB suspend mode
TXLED#	Drives LED during USB transmit
RXLED#	Drives LED during USB receive
TX or RX LED#	Drives LED during USB transmit or receive
BCD0 BCD1	Configurable battery charger detect pins to indicate type of USB charger (SDP, CDP, or DCP) Configuration example: 00 - Draw up to 100 mA (Unconfigured state) 01 - SDP (up to 500 mA) 10 - CDP/DCP (up to 1.5 A) 11 - Suspend (up to 2.5 mA) This truth table can be configured using the configuration utility
BUSDETECT	VBUS detection. Connect VBUS to this pin via resistor network for VBUS detection when using BCD feature (refer to page 20).
CS0, CS1, CS2, CS3, CS4, CS5, CS6, CS7	CapSense button input (Max up to 8)
CSout0, CSout1, CSout2, CSout3	Indicates which CapSense button is pressed
Cmod (Available on GPIO_0 only)	External modulator capacitor, connect a 2.2 nF capacitor ($\pm 10\%$) to ground
Cshield (optional)	Shield for waterproofing

Note: These signal options can be configured on any of the available GPIO pins using Cypress-supplied configuration utility.

USB Power Configurations

The following section describes possible USB power configurations for the CY7C65215. Refer to the [Pin Description on page 13](#) for signal details.

USB Bus-Powered Configuration

Figure 4 shows an example of the CY7C65215 in a bus-powered design. VBUS is connected directly to the CY7C65215 because it has an internal regulator.

The USB bus-powered system must comply with the following requirements:

1. The system should not draw more than 100 mA prior to USB enumeration (Unconfigured state).
2. The system should not draw more than 2.5 mA during USB Suspend mode.
3. A high-power bus-powered system (can draw more than 100 mA when operational) must use POWER# (configured over GPIO) to keep the current consumption below 100 mA prior to USB enumeration, and 2.5 mA during USB Suspend state.
4. The system should not draw more than 500 mA from the USB host.

The configuration descriptor in the CY7C65215 flash should be updated to indicate bus power and the maximum current required by the system using the configuration utility.

Figure 4. Bus Powered Configuration

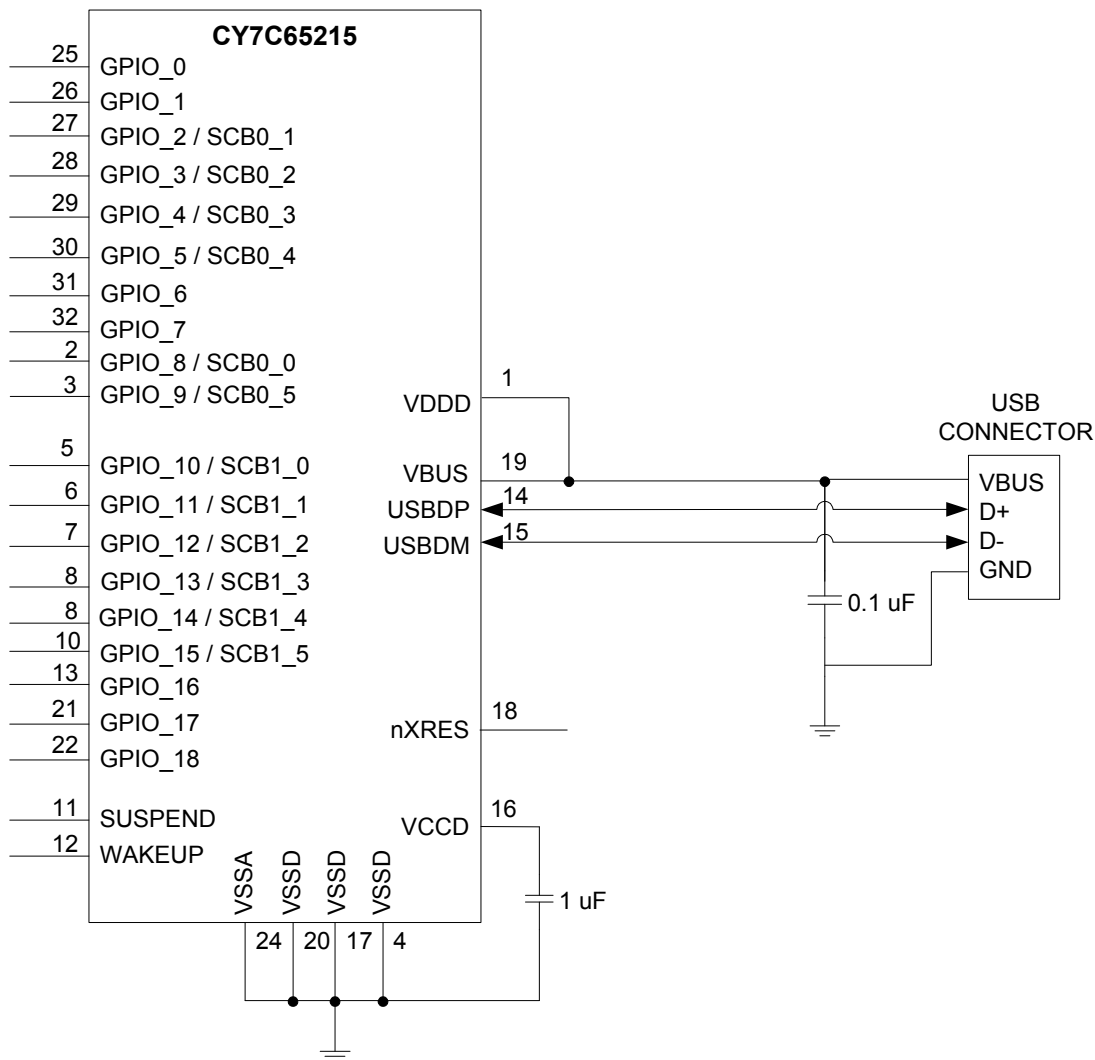

Self Powered Configuration

Figure 5 shows an example of CY7C65215 in a self-powered design. A self-powered system does not use VBUS from the host to power the system but has its own power supply. A self-powered system has no restriction on current consumption because it does not draw any current from the VBUS.

When VBUS is present, CY7C65215 enables an internal, 1.5-kΩ pull-up resistor on USBDP. When VBUS is absent (USB host is powered down), CY7C65215 removes the 1.5-kΩ pull-up resistor on USBDP, and this ensures no current flows from the

USBDP to the USB host via a 1.5-kΩ pull-up resistor, to comply with USB 2.0 specification.

When reset is asserted to CY7C65215, all the I/O pins are tristated.

Using the configuration utility, the configuration descriptor in the CY7C65213 flash should be updated to indicate that it is self-powered.

Figure 5. Self Powered Configuration

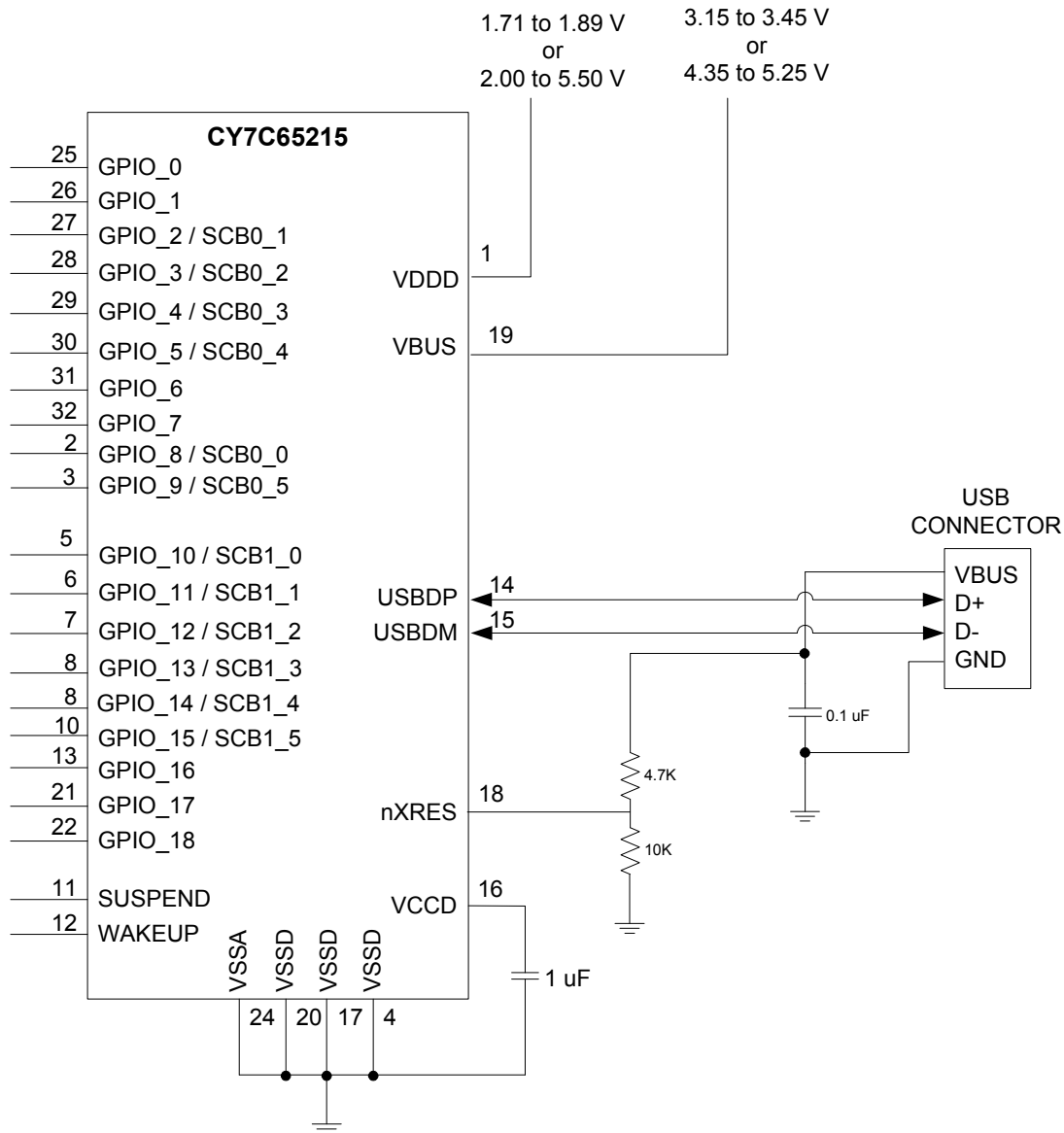

USB Bus Powered with Variable I/O Voltage

Figure 6 shows CY7C65215 in a bus-powered system with variable I/O voltage. A low dropout (LDO) regulator is used to supply 1.8 V or 3.3 V (using a jumper switch) the input of which is 5 V from VBUS. Another jumper switch is used to select 1.8/3.3 V or 5 V from VBUS for the VDDD pin of CY7C65215. This allows I/O voltage and supply to external logic to be selected among 1.8 V, 3.3 V, or 5 V.

The USB bus-powered system must comply with the following:

- The system should not draw more than 100 mA prior to USB enumeration (Unconfigured state).

- The system should not draw more than 2.5 mA during USB Suspend mode.
- A high-power bus-powered system (can draw more than 100 mA when operational) must use POWER# (configured over GPIO) to keep the current consumption below 100 mA prior to USB enumeration and 2.5 mA during USB Suspend state.

Figure 6. USB Bus Powered with 1.8 V, 3.3 V, or 5 V Variable I/O Voltage [4]

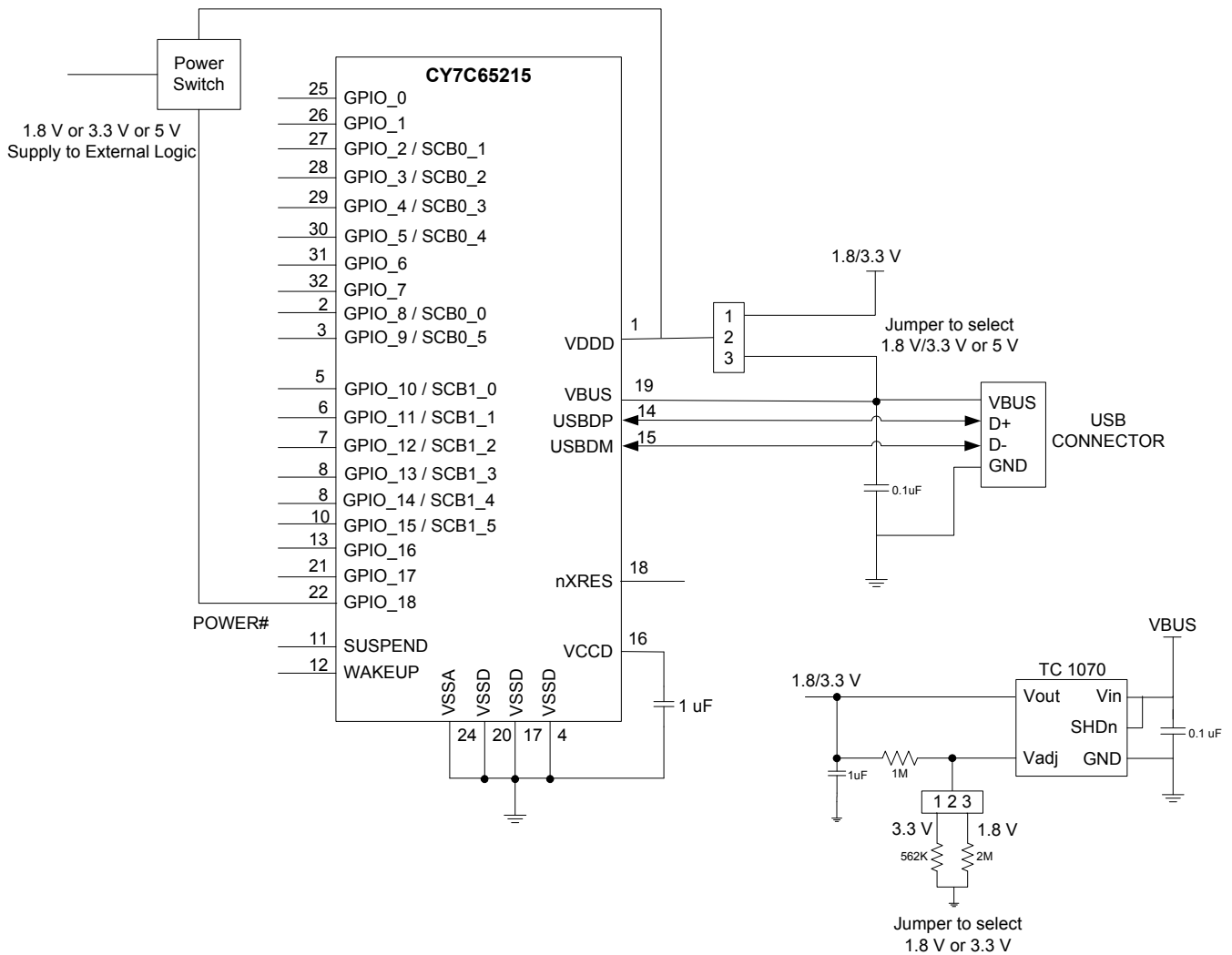

Note

4. $1.71\text{ V} \leq \text{VDDD} \leq 1.89\text{ V}$ - Short VCCD pin with VDDD pin; $\text{VDDD} > 2\text{ V}$ - connect a 1- μF decoupling capacitor to the VCCD pin.

Application Examples

The following section provides CY7C65215 application examples.

USB-to-Dual UART Bridge with Battery-Charge Detection

CY7C65215 can connect any embedded system, with a serial port, to a host PC through USB. CY7C65215 enumerates as a dual COM port on the host PC.

SUSPEND is connected to the MCU to indicate USB suspend or USB Unconfigured and the WAKEUP pin is used to wake up CY7C65215, which in turn issues a remote wakeup to the USB host. GPIO1 and GPIO0 are configured as RXLED# and TXLED# to drive two LEDs indicating data receive and transmit respectively.

CY7C65215 implements the battery charger detection functionality based on the USB Battery Charging Specification Rev 1.2. Battery-operated bus power systems must comply with the following conditions:

- The system can be powered from the battery (if not discharged) and be operational if VBUS is not connected or powered down.
- The system should not draw more than 100 mA from the VBUS prior to USB enumeration and USB Suspend mode.

- The system should not draw more than 500 mA for SDP and 1.5 A for CDP/DCP

To comply with the first requirement, VBUS from the USB host is connected to the battery charger as well as CY7C65215 as shown in Figure 7. When VBUS is connected, CY7C65215 initiates battery charger detection and indicates the type of USB charger over BCD0 and BCD1. If the USB charger is SDP or CDP, CY7C65215 enables a 1.5-K pull-up resistor on the USBDP for Full-Speed enumeration. When VBUS is disconnected CY7C65215 indicates absence of the USB charger over BCD0 and BCD1, and removes the 1.5-K pull-up resistor on USBDP. Removing this resistor ensures no current flows from the supply to the USB host through the USBDP, to comply with the USB 2.0 specification.

To comply with the second and third requirements, two signals (BCD0 and BCD1) are configured over GPIO to communicate the type of USB host charger and the amount of current it can draw from the battery charger. The BCD0 and BCD1 signals can be configured using the configuration utility.

Figure 7. USB to Dual UART Bridge with Battery Charge Detection^[5]

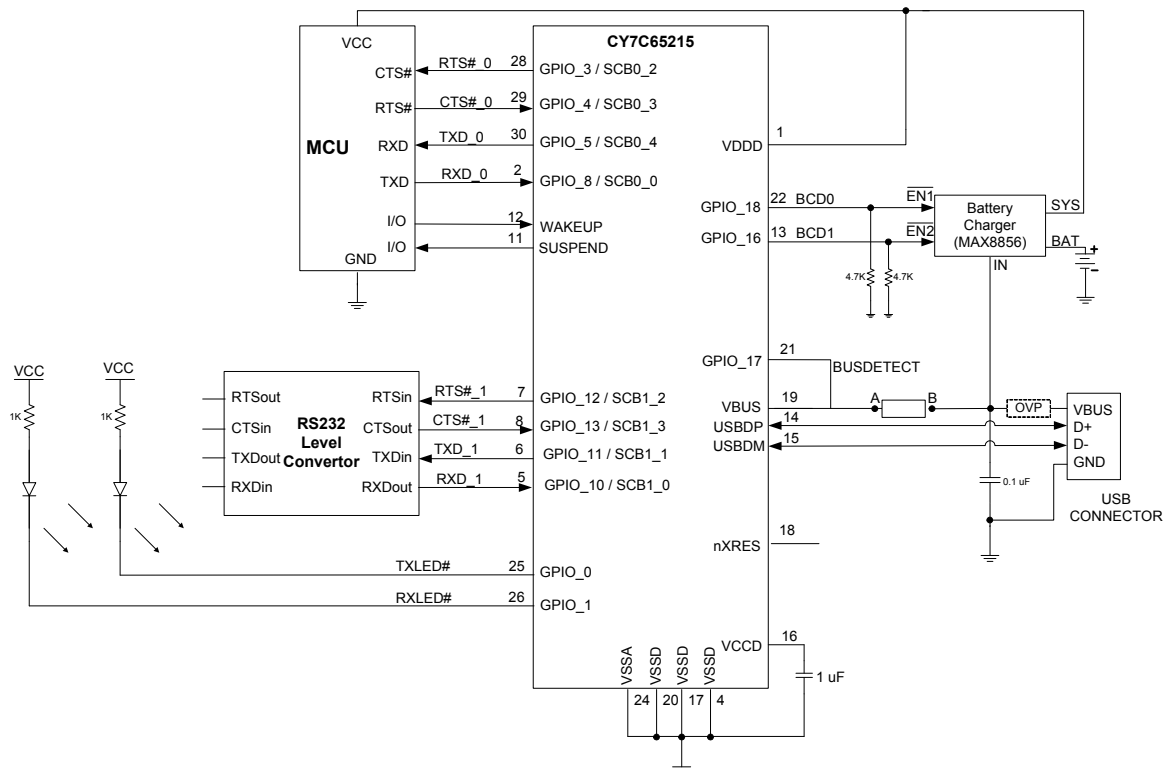

Note

5. Add a 100 K pull-down resistor on the V_{BUS} pin for quick discharge.

In a battery charger system, a 9-V spike on the VBUS is possible. The CY7C65215 VBUS pin is intolerant to voltage above 6 V. In the absence of over-voltage protection (OVP) on the VBUS line, VBUS should be connected to BUSDETECT (GPIO configured) using the resistive network and the output of battery charger to the VBUS pin of CY7C65215, as shown in the following figure.

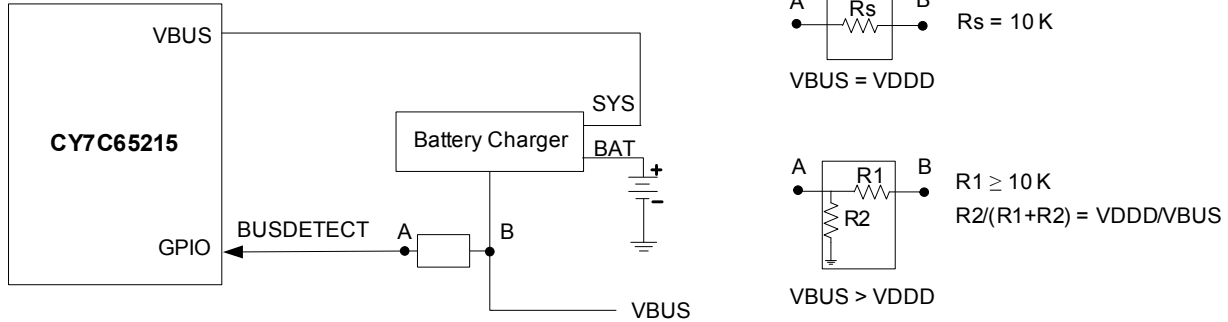

When VBUS and VDDD are at the same voltage potential, VBUS can be connected to GPIO using a series resistor (R_s). This is shown in Figure 8. If there is a charger failure and VBUS becomes 9 V, then the 10-k Ω resistor plays two roles. It reduces the amount of current flowing into the forward biased diodes in the GPIO, and it reduces the voltage seen on the pad.

Figure 8. GPIO VBUS Detection, VBUS = VDDD

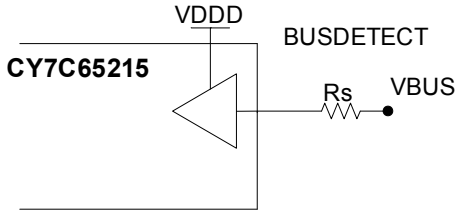

When VBUS > VDDD, a resistor voltage divider is necessary to reduce the voltage from VBUS down to VDDD for the GPIO sensing the VBUS voltage. This is shown in the following figure. The resistors should be sized as follows:

$R_1 \geq 10\text{ K}$
 $R_2 / (R_1 + R_2) = V_{DDD} / V_{BUS}$

The first condition limits the voltage and current for the charger failure situation, as described in the previous paragraph, while the second condition allows for normal-operation VBUS detection.

Figure 9. GPIO VBUS Detection, VBUS > VDDD

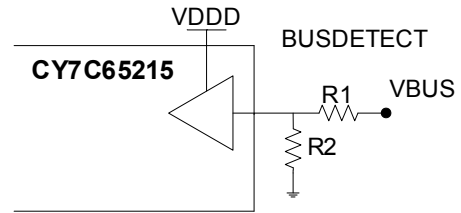

CapSense

In Figure 10 CY7C65215 is configured to support six CapSense buttons. Three GPIOs (CSout0, CSout1, and CSout2) are configured to indicate which CapSense button is pressed by the finger. It also implements a 2-pin UART on SCB0 and a 4-pin UART on SCB1.

A 2.2-nF (10%) capacitor (Cmod) must be connected on the GPIO_0 pin for proper CapSense operation. Optionally, the GPIO_7 pin is configured as Cshield and connected to the shield

of the CapSense button as shown in Figure 10. The shield prevents false triggering of buttons due to water droplets and guarantees CapSense operation (sensors respond to finger touch).

For further information on CapSense, refer to [Getting Started with CapSense](#).

Figure 10. CapSense Schematic

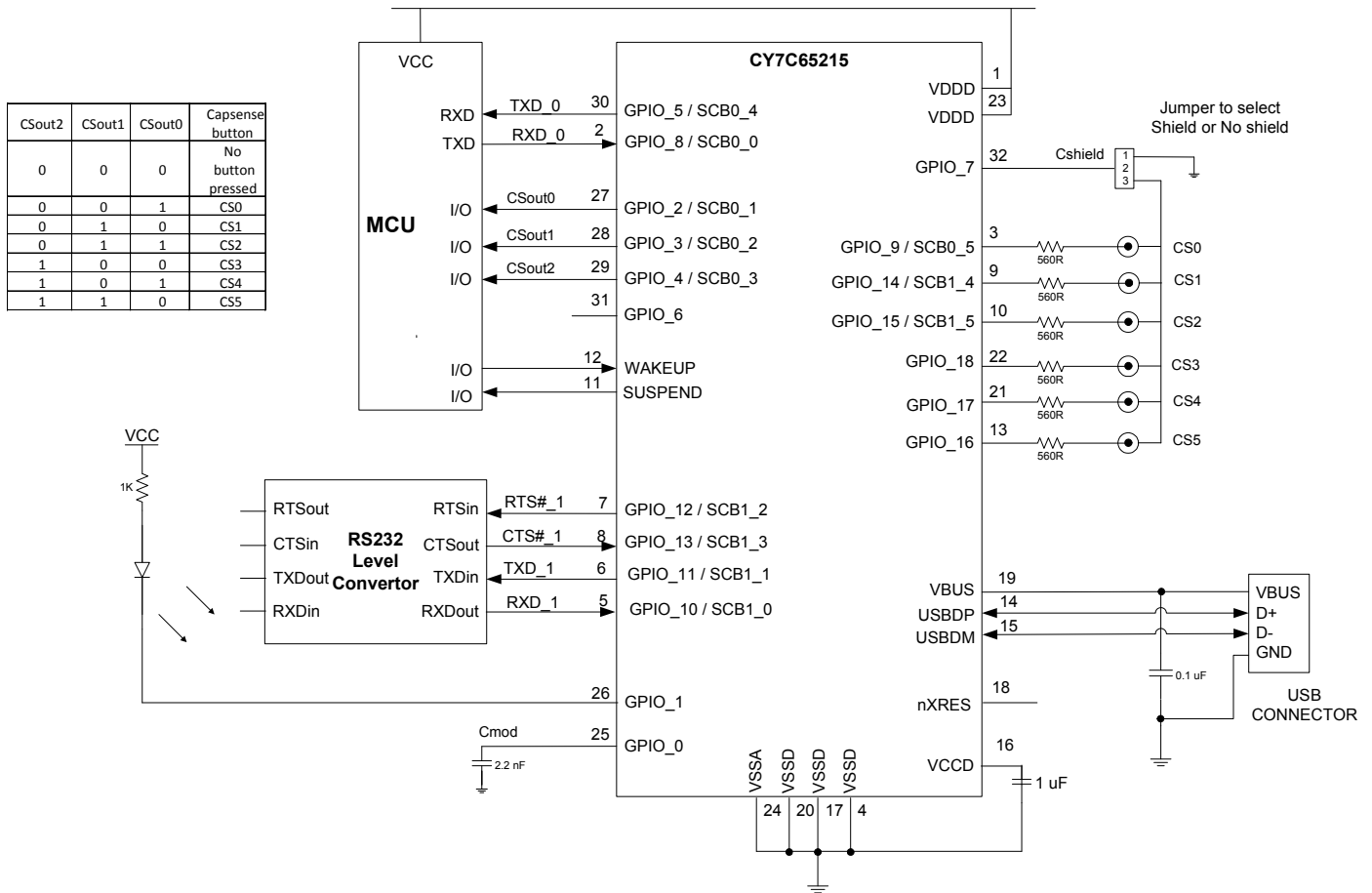

USB-to-Dual Channel (I2C/SPI) Bridge

In Figure 11, CY7C65215 is configured as a USB-to-Dual Channel (I2C/SPI) Bridge. GPIO1 and GPIO0 are configured as RXLED# and TXLED# to drive two LEDs indicating data USB receive and transmit respectively.

Figure 11. USB to I2C/SPI Bridge

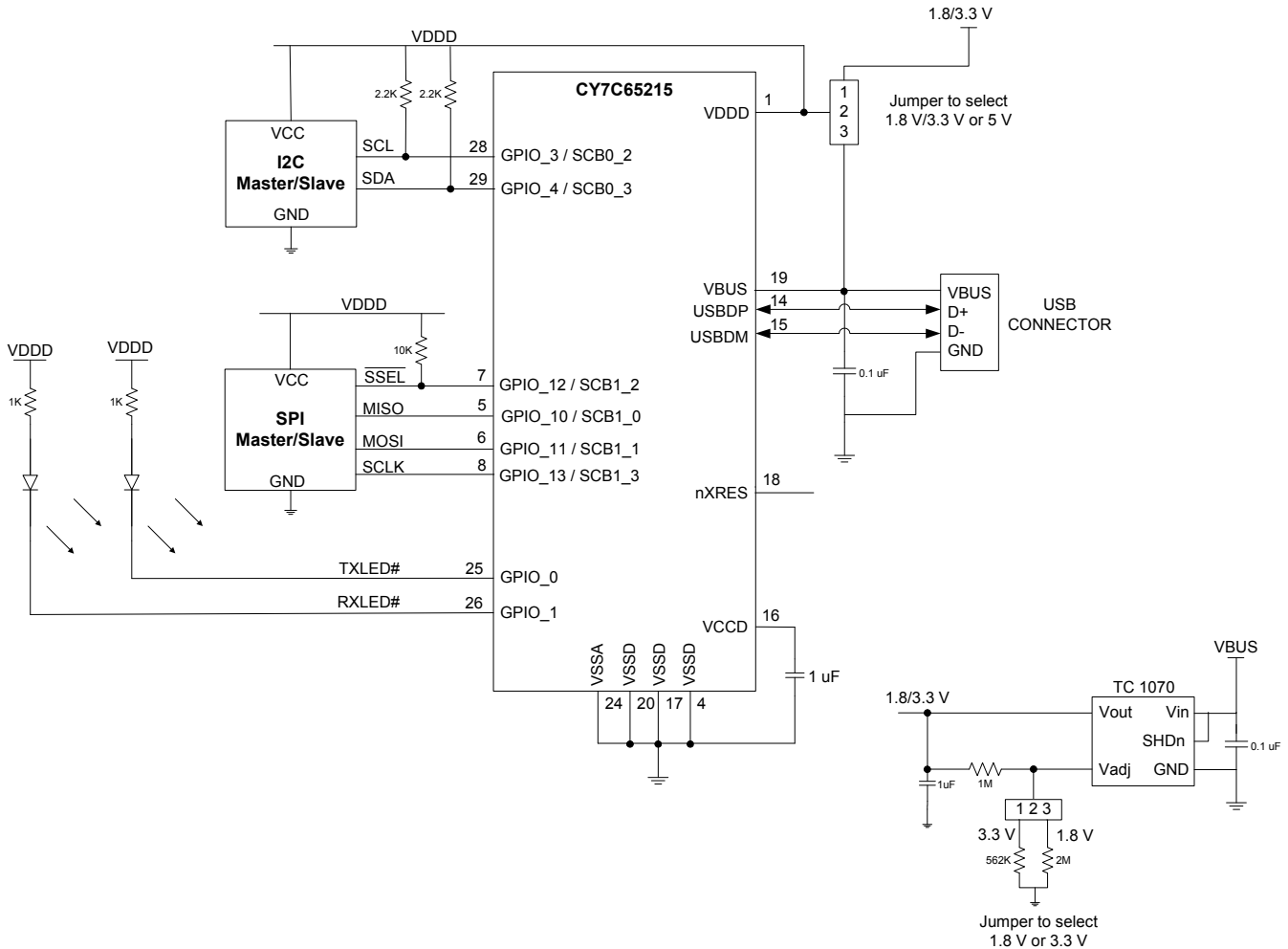

I2C

The CY7C65215 I2C can be configured as a Master or Slave using the configuration utility. CY7C65215 supports I2C data rates up to 100 kbits/s in the standard mode (SM) and 400 kbits/s in the fast mode (FM).

In the master mode, SCL is output from CY7C65215. In the slave mode, SCL is input to CY7C65215. The I2C slave address for CY7C65215 can be configured using the configuration utility. The SDA data line is bi-directional in the master and slave modes. The drive modes of the SCL and SDA port pins are always open drain.

Refer to the NXP I2C specification for further details on protocol.

SPI

The CY7C65215 SPI can be configured as a Master or Slave using the configuration utility. CY7C65215 supports SPI frequency up to 3 MHz. It can support transaction sizes ranging from 4 bits to 16 bits, which can be configured using the configuration utility.

In the master mode, SCLK, MOSI and SSEL lines act as output and MISO acts as an input. In the slave mode, SCL SCLK, MOSI, and SSEL lines act as input and MISO acts as an output.

CY7C65215 supports three versions of the SPI protocol:

- Motorola - This is the original SPI protocol.
- Texas Instruments - A variation of the original SPI protocol in which data frames are identified by a pulse on the SSEL line.
- National Semiconductors - A half-duplex variation of the original SPI protocol.

Motorola

The original SPI protocol is defined by Motorola. It is a full-duplex protocol: transmission and reception occur at the same time.

A single (full-duplex) data transfer follows these steps: The master selects a slave by driving its SSEL line to '0'. Next, it drives data on its MOSI line and it drives a clock on its SCLK line. The slave uses the edges of the transmitted clock to capture the data on the MOSI line. The slave drives data on its MISO line. The master captures the data on the MISO line. The process is repeated for all the bits in the data transfer.

Multiple data transfers may happen without the SSEL line changing from '0' to '1' and back from '1' to '0' in between the individual transfers. As a result, slaves must keep track of the progress of data transfers to separate individual transfers.

When not transmitting data, the SSEL line is '1' and SCLK is typically off.

The Motorola SPI protocol has four different modes that determine how data is driven and captured on the MOSI and MISO lines. These modes are determined by clock polarity (CPOL) and clock phase (CPHA). Clock polarity determines the value of the SCLK line when not transmitting data:

- CPOL is '0': SCLK is '0' when not transmitting data.
- CPOL is '1': SCLK is '1' when not transmitting data.

Clock phase determines when data is driven and captured. It is dependent on the value of CPOL:

Table 17. SPI Protocol Modes

Mode	CPOL	CPHA	Description
0	0	0	Data is driven on a falling edge of SCLK. Data is captured on a rising edge of SCLK
1	0	1	Data is driven on a rising edge of SCLK. Data is captured on a falling edge of SCLK
2	1	0	Data is driven on a rising edge of SCLK. Data is captured on a falling edge of SCLK
3	1	1	Data is driven on a falling edge of SCLK. Data is captured on a rising edge of SCLK

Figure 12. Driving and Capturing of MOSI/MISO Data As A Function of CPOL and CPHA

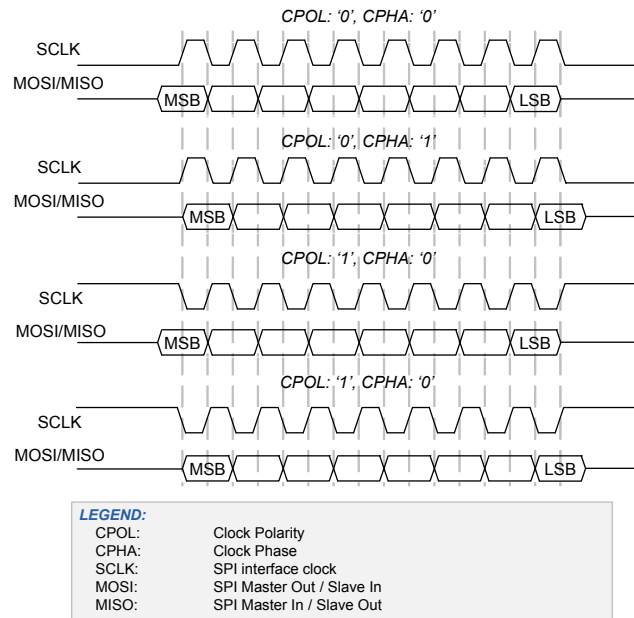
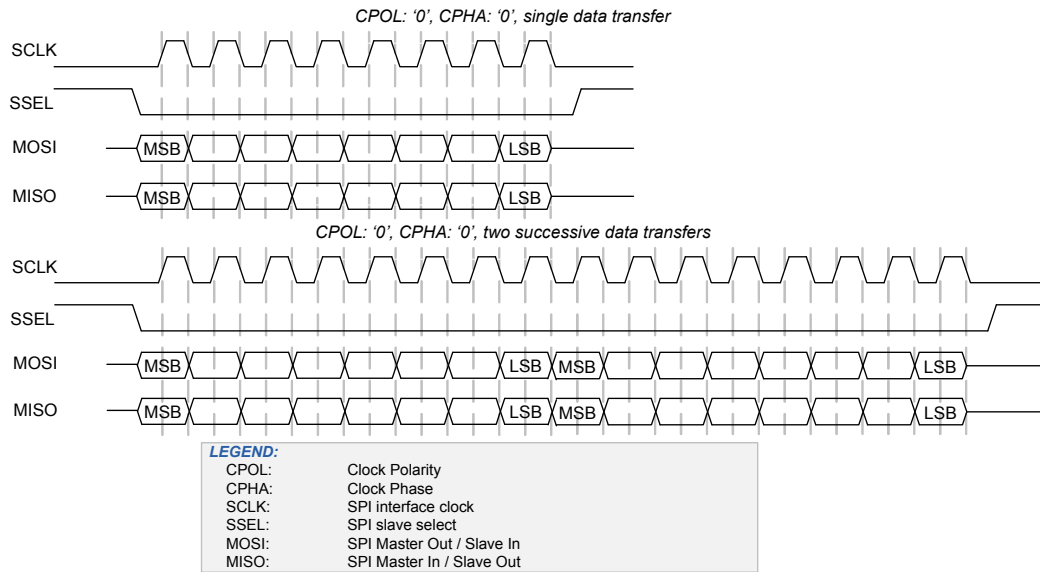

Figure 13. Single 8-bit Data Transfer and Two Successive 8-bit Data Transfers in Mode 0 (CPOL is '0', CPHA is '0')



Texas Instruments

The Texas Instruments' SPI protocol redefines the use of the SSEL signal. It uses the signal to indicate the start of a data transfer, rather than a low, active slave-select signal. The start of a transfer is indicated by a high, active pulse of a single-bit transfer period. This pulse may occur one cycle before the transmission of the first data bit, or may coincide with the transmission of the first data bit. The transmitted clock SCLK is a free-running clock.

The TI SPI protocol only supports mode 1 (CPOL is '0' and CPHA is '1'): data is driven on a rising edge of SCLK and data is captured on a falling edge of SCLK.

The following figure illustrates a single 8-bit data transfer and two successive 8-bit data transfers. The SSEL pulse precedes the first data bit. Note how the SSEL pulse of the second data transfer coincides with the last data bit of the first data transfer.

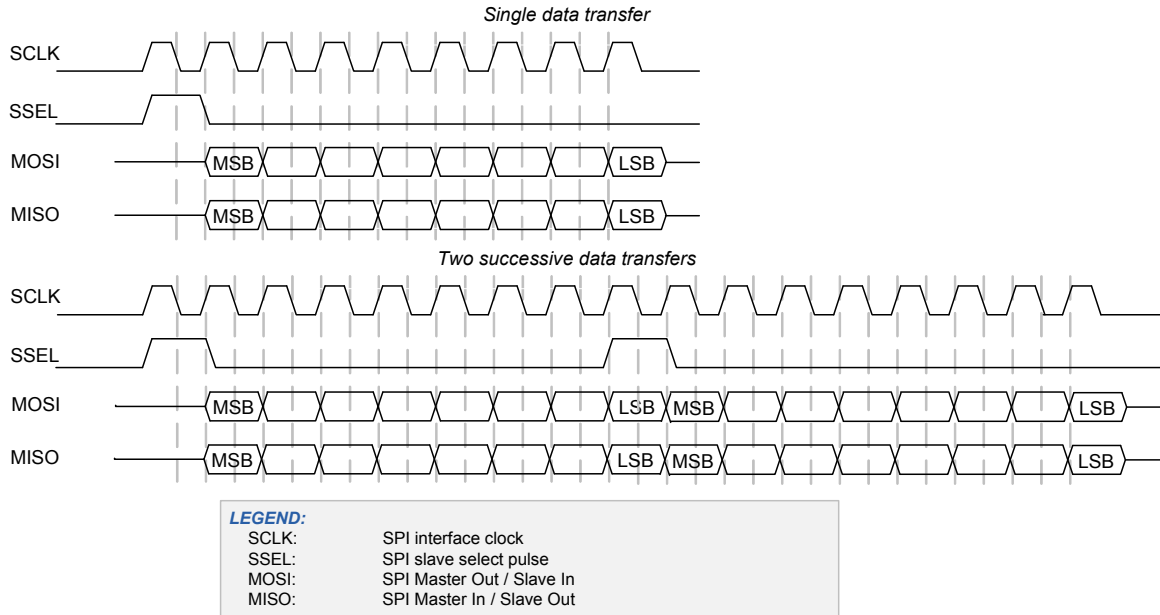

The following figure illustrates a single 8-bit data transfer and two successive 8-bit data transfers. The SSEL pulse coincides with the first data bit.

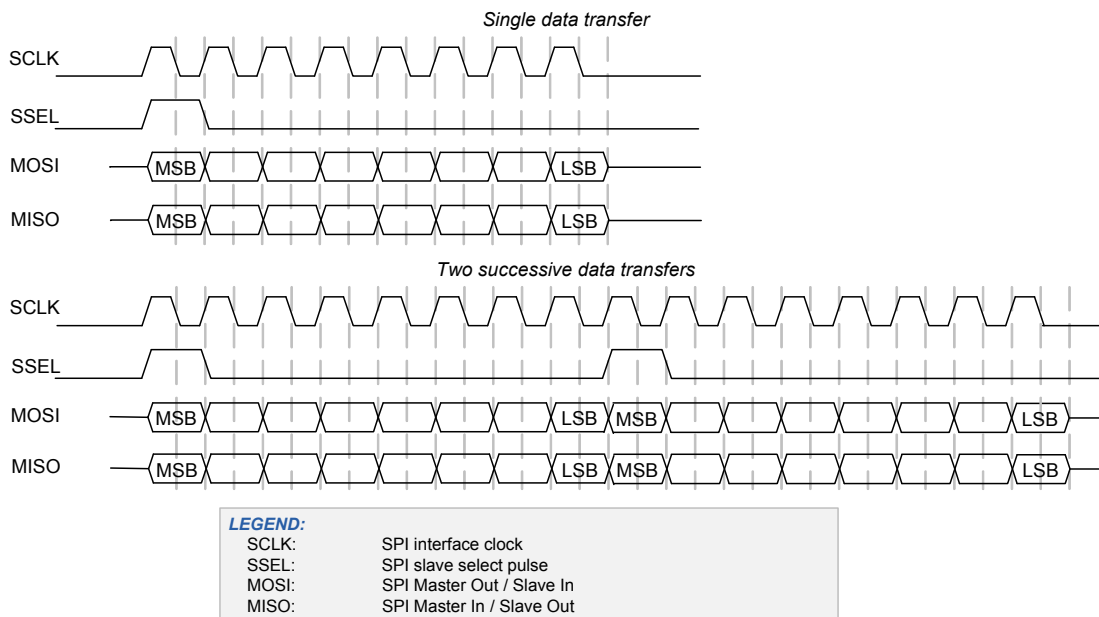

National Semiconductors

The National Semiconductors' SPI protocol is a half-duplex protocol. Rather than transmission and reception occurring at the same time, transmission and reception take turns (transmission happens before reception). A single "idle" bit transfer period separates transmission from reception.

Note: Successive data transfers are NOT separated by an "idle" bit transfer period.

The transmission data transfer size and reception data transfer size may differ. The National Semiconductors' SPI protocol only supports mode 0: data is driven on a falling edge of SCLK and data is captured on a rising edge of SCLK.

The following figure illustrates a single data transfer and two successive data transfers. In both cases, the transmission data transfer size is 8 bits and the reception transfer size is 4 bits.

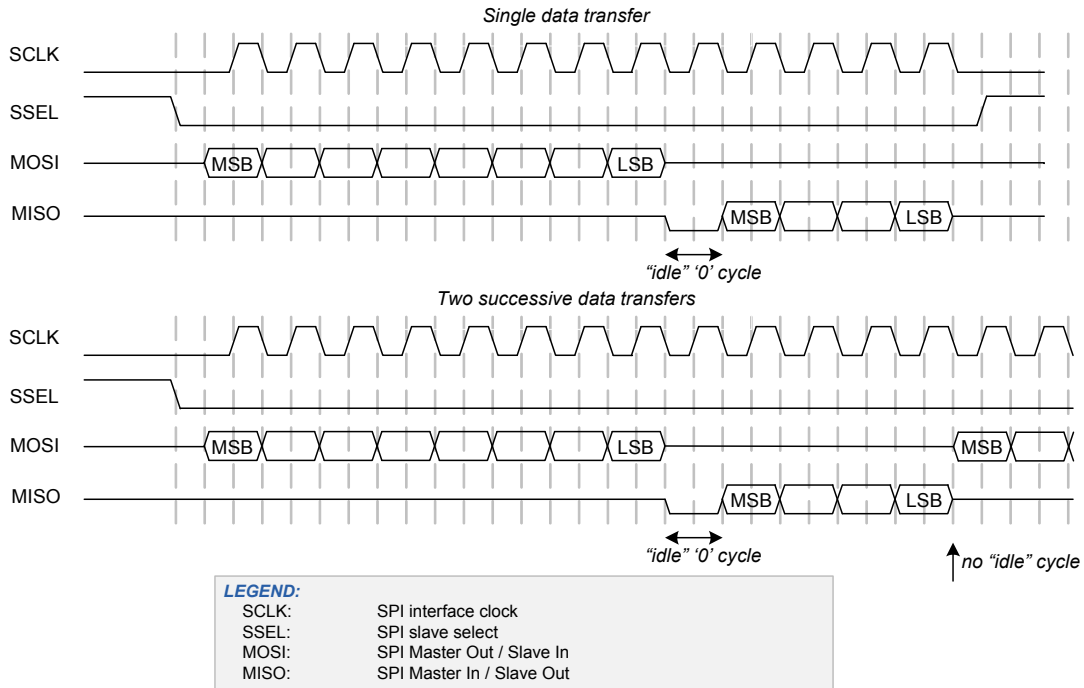

The above figure defines MISO and MOSI as undefined when the lines are considered idle (not carrying valid information). It will drive the outgoing line values to '0' during idle time (to satisfy the requirements of specific master devices (NXP LPC17xx) and specific slave devices (MicroChip EEPROM)).

Ordering Information

Table 18 lists the CY7C65215 key package features and ordering codes. For more information, contact your local sales representative.

Table 18. Key Features and Ordering Information

Package	Ordering Code	Operating Range
32-pin QFN (5 × 5 × 1 mm, 0.5 mm pitch) (Pb-free)	CY7C65215-32LTXI	Industrial
32-pin QFN (5 × 5 × 1 mm, 0.5 mm pitch) (Pb-free) – Tape and Reel	CY7C65215-32LTXIT	Industrial

Ordering Code Definitions

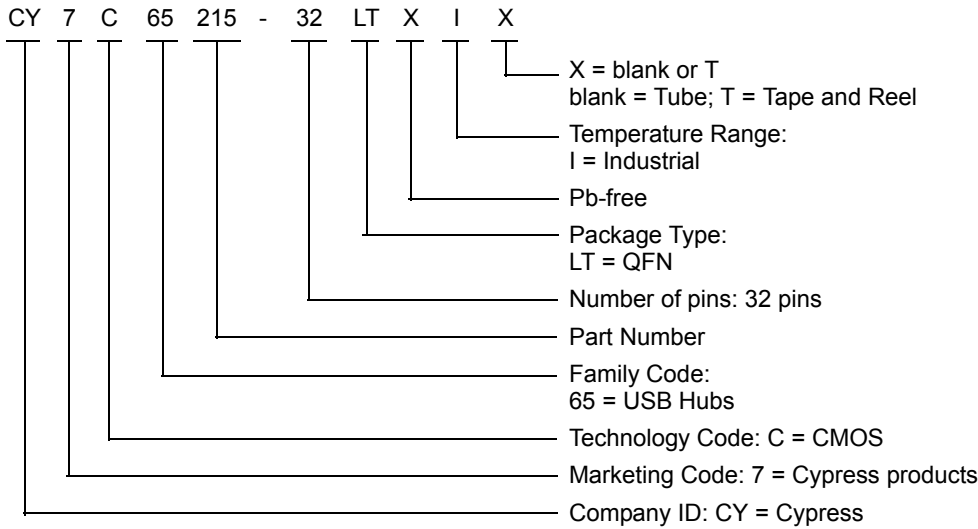

Package Information

The package currently planned to be supported is the 32-pin QFN.

Figure 14. 32-pin QFN 5 × 5 × 1.0 mm LT32B 3.5 × 3.5 EPAD (Sawn)

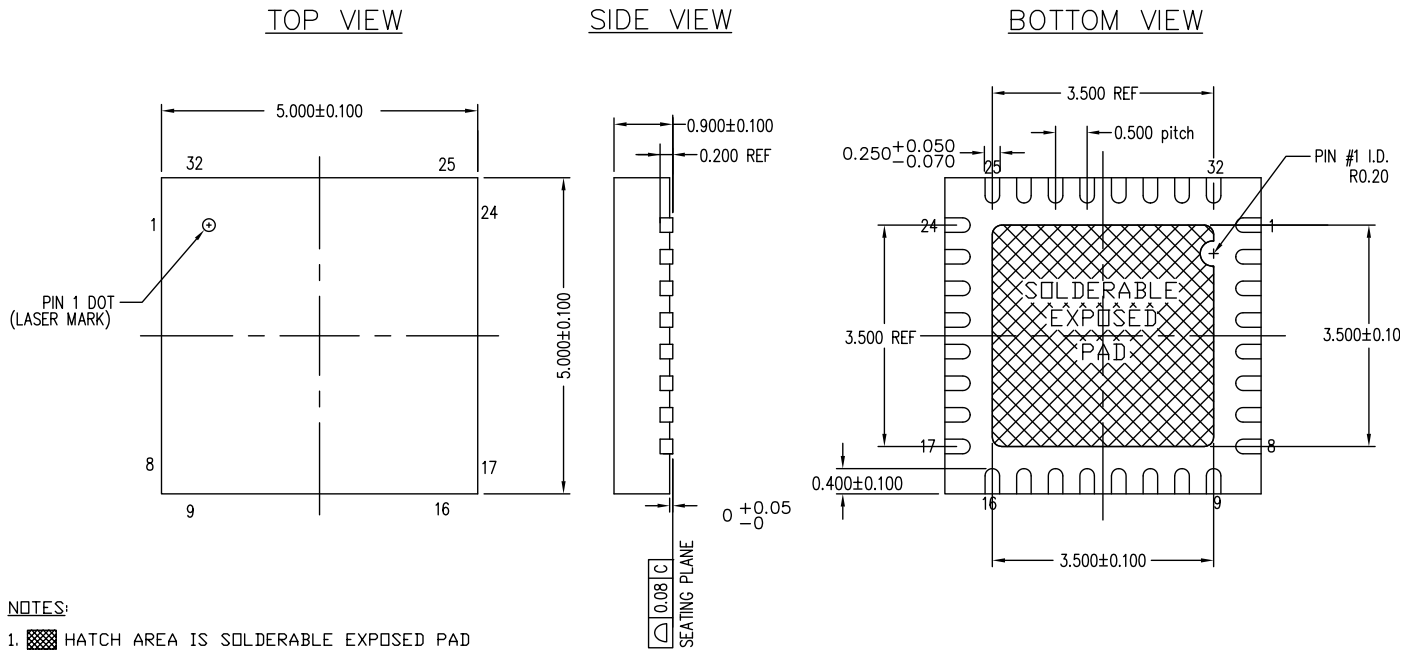

NOTES:

1.  HATCH AREA IS SOLDERABLE EXPOSED PAD
2. BASED ON REF JEDEC # MO-220
3. DIMENSIONS ARE IN MILLIMETERS
4. PACKAGE WEIGHT: SEE CYPRESS PACKAGE MATERIAL DECLARATION DATASHEET (PMDD) POSTED ON THE CYPRESS WEB

001-30999 *D

Table 19. Package Characteristics

Parameter	Description	Min	Typ	Max	Units
T _A	Operating ambient temperature	-40	25	85	°C
THJ	Package θ _{JA}	-	19	-	°C/W

Table 20. Solder Reflow Peak Temperature

Package	Maximum Peak Temperature	Maximum Time at Peak Temperature
32-pin QFN	260 °C	30 seconds

Table 21. Package Moisture Sensitivity Level (MSL), IPC/JEDEC J-STD-2

Package	MSL
32-pin QFN	MSL 3

Acronyms

Table 22. Acronyms Used in this Document

Acronym	Description
BCD	battery charger detection
CDC	communication driver class
CDP	charging downstream port
DCP	dedicated charging port
DLL	dynamic link library
ESD	electrostatic discharge
GPIO	general purpose input/output
HBM	human-body model
I ² C	inter-integrated circuit
MCU	Microcontroller Unit
OSC	oscillator
PHDC	personal health care device class
PID	Product Identification
SCB	serial communication block
SCL	I2C Serial Clock
SDA	I2C Serial Data
SDP	Standard Downstream Port
SIE	serial interface engine
SPI	serial peripheral interface
VCOM	virtual communication port
USB	Universal Serial Bus
UART	universal asynchronous receiver transmitter
VID	Vendor Identification

Document Conventions

Units of Measure

Table 23. Units of Measure

Symbol	Unit of Measure
°C	degree Celsius
DMIPS	dhystone million instructions per second
kΩ	kilo-ohm
KB	kilobyte
kHz	kilohertz
kV	kilovolt
Mbps	megabits per second
MHz	megahertz
mm	millimeter
V	volt

Document History Page

Document Title: CY7C65215 USB-Serial Dual Channel (UART/I ² C/SPI) Bridge with CapSense [®] and BCD Document Number: 001-81006				
Revision	ECN	Orig. of Change	Submission Date	Description of Change
*G	4287738	SAMT	02/21/2014	Updated Ordering Information (Updated part numbers).

Sales, Solutions, and Legal Information

Worldwide Sales and Design Support

Cypress maintains a worldwide network of offices, solution centers, manufacturer's representatives, and distributors. To find the office closest to you, visit us at [Cypress Locations](#).

Products

Automotive	cypress.com/go/automotive
Clocks & Buffers	cypress.com/go/clocks
Interface	cypress.com/go/interface
Lighting & Power Control	cypress.com/go/powerpsoc cypress.com/go/plc
Memory	cypress.com/go/memory
PSoC	cypress.com/go/psoc
Touch Sensing	cypress.com/go/touch
USB Controllers	cypress.com/go/USB
Wireless/RF	cypress.com/go/wireless

PSoC[®] Solutions

[psoc.cypress.com/solutions](#)
[PSoC 1](#) | [PSoC 3](#) | [PSoC 4](#) | [PSoC 5LP](#)

Cypress Developer Community

[Community](#) | [Forums](#) | [Blogs](#) | [Video](#) | [Training](#)

Technical Support

[cypress.com/go/support](#)

© Cypress Semiconductor Corporation, 2012-2014. The information contained herein is subject to change without notice. Cypress Semiconductor Corporation assumes no responsibility for the use of any circuitry other than circuitry embodied in a Cypress product. Nor does it convey or imply any license under patent or other rights. Cypress products are not warranted nor intended to be used for medical, life support, life saving, critical control or safety applications, unless pursuant to an express written agreement with Cypress. Furthermore, Cypress does not authorize its products for use as critical components in life-support systems where a malfunction or failure may reasonably be expected to result in significant injury to the user. The inclusion of Cypress products in life-support systems application implies that the manufacturer assumes all risk of such use and in doing so indemnifies Cypress against all charges.

Any Source Code (software and/or firmware) is owned by Cypress Semiconductor Corporation (Cypress) and is protected by and subject to worldwide patent protection (United States and foreign), United States copyright laws and international treaty provisions. Cypress hereby grants to licensee a personal, non-exclusive, non-transferable license to copy, use, modify, create derivative works of, and compile the Cypress Source Code and derivative works for the sole purpose of creating custom software and or firmware in support of licensee product to be used only in conjunction with a Cypress integrated circuit as specified in the applicable agreement. Any reproduction, modification, translation, compilation, or representation of this Source Code except as specified above is prohibited without the express written permission of Cypress.

Disclaimer: CYPRESS MAKES NO WARRANTY OF ANY KIND, EXPRESS OR IMPLIED, WITH REGARD TO THIS MATERIAL, INCLUDING, BUT NOT LIMITED TO, THE IMPLIED WARRANTIES OF MERCHANTABILITY AND FITNESS FOR A PARTICULAR PURPOSE. Cypress reserves the right to make changes without further notice to the materials described herein. Cypress does not assume any liability arising out of the application or use of any product or circuit described herein. Cypress does not authorize its products for use as critical components in life-support systems where a malfunction or failure may reasonably be expected to result in significant injury to the user. The inclusion of Cypress' product in a life-support systems application implies that the manufacturer assumes all risk of such use and in doing so indemnifies Cypress against all charges.

Use may be limited by and subject to the applicable Cypress software license agreement.