

ISOMETRIC

O.P. (MM)	P.T. (MM)
9.5 ±0.8	4.4 MAX

O.P. = OPERATING POINT
P.T. = PRE-TRAVEL

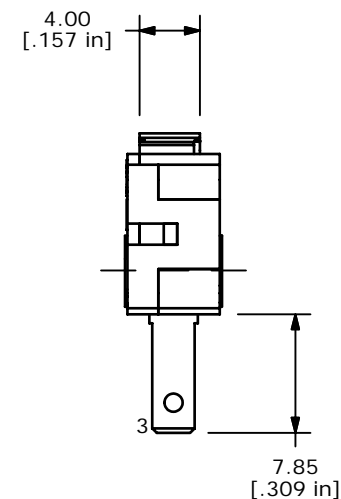
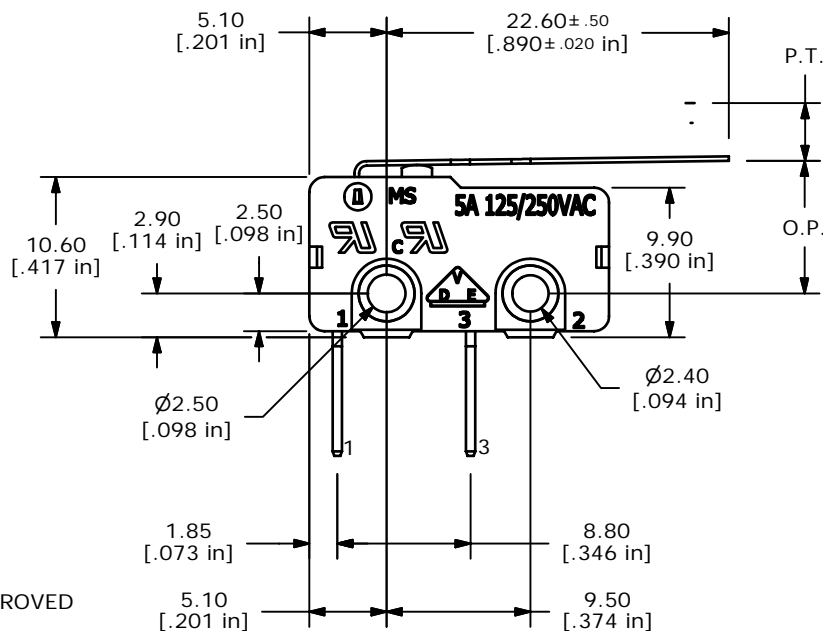
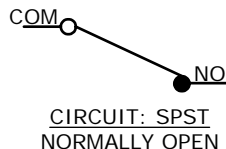

NOTES:

1. ALL DIMENSIONS IN MM [INCH]
2. GENERAL TOLERANCE: X.X=±0.4
X.XX=±0.25
3. RATING: 5A @125/250VAC UL, CUL, VDE, APPROVED
- ▲ 4. OPERATING FORCE: 010±05 GRAMS
5. OPERATING TEMP: -25°C TO 85°C
6. ELECTRICAL LIFE: 50,000 CYCLES MIN.
7. MECHANICAL LIFE: 1,000,000 CYCLES TYP.
8. INSULATION RESISTANCE: 100 MΩ
9. DIELECTRIC STRENGTH: 1000VAC 1 MINUTE (INITIAL VALUE)
10. CONTACT RESISTANCE: 100 MILLI-OHMS MAX.
11. 2002/95/EC (ROHS) COMPLIANT
12. ▲ DENOTES CRITICAL PARAMETER.



B	16722	REMOVED NC TERMINAL	12/1/06	TN
A	16693	RELEASED FOR PRODUCTION	11/30/06	TN
REV	PCR NO	DESCRIPTION	DATE	BY

TITLE MS0850503F010C1C				
SCALE	DATE	DR	DWG	REV
2:1	12/1/2006	TN	Q970067	B

THE INFORMATION CONTAINED IN THIS DOCUMENT IS PROPRIETARY TO E-SWITCH AND IS NOT TO BE COPIED OR TRANSFERRED