

CGA6M1X7T2J154K200AE

TDK Item Description : CGA6M1X7T2J154KT***S



Equivalent C3225X7T2J154K for Automotive

Application & Main Feature

Automotive Grade (Soft Termination)

Series

CGA6(3225) [EIA CC1210]

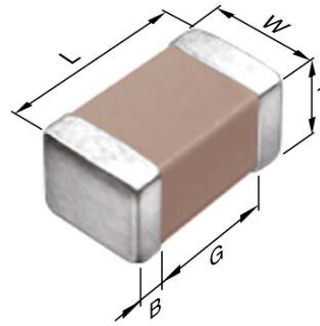

Dimensions

L	3.20mm +0.5,-0.4mm
W	2.50mm +/-0.3mm
T	2.00mm +0.3,-0.2mm
B	0.2mm Min.
G	

Temperature Characteristic

X7T (-55 to 125 degC +22,-33%)

Rated Voltage

2J (630Vdc)

Capacitance

150nF

Capacitance Tolerance

K (+/-10%)

Dissipation Factor

2.5% Max.

Insulation Resistance

3.33Gohm Min.

AEC-Q200

Yes

DC Bias Characteristic

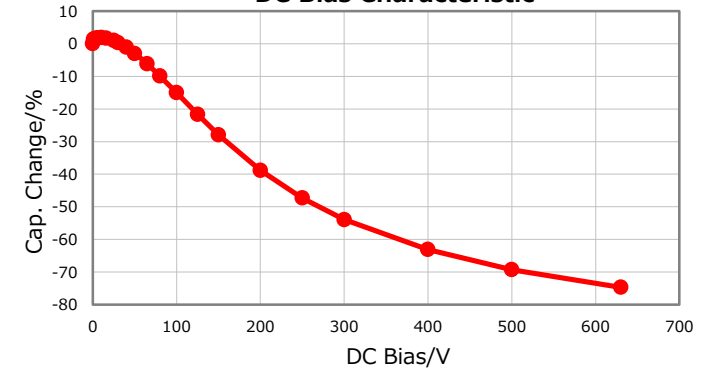

|Z|, ESR vs. Freq. Characteristics

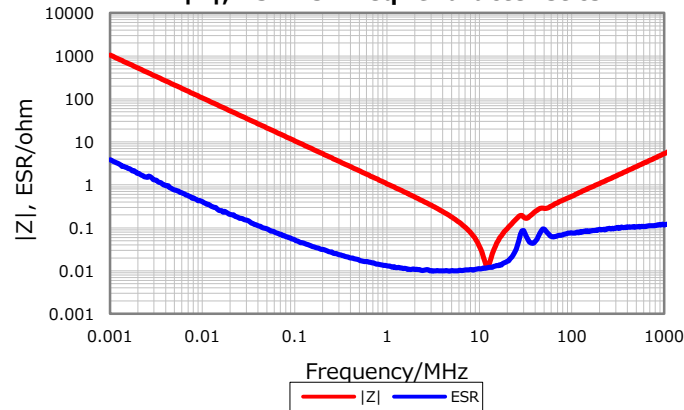

Temperature Characteristics

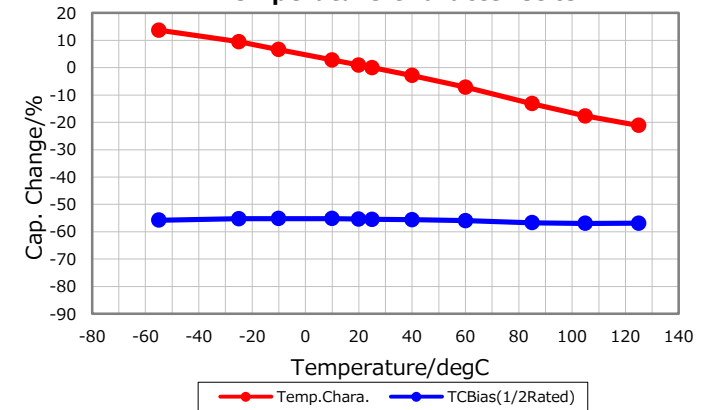

Cap. vs. Freq. Characteristic

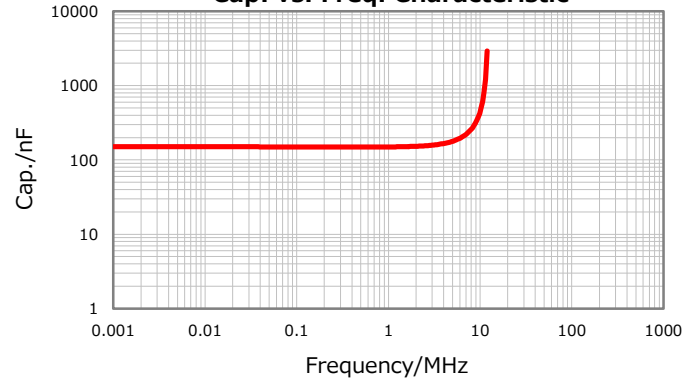

Ripple Temperature Rise Characteristics

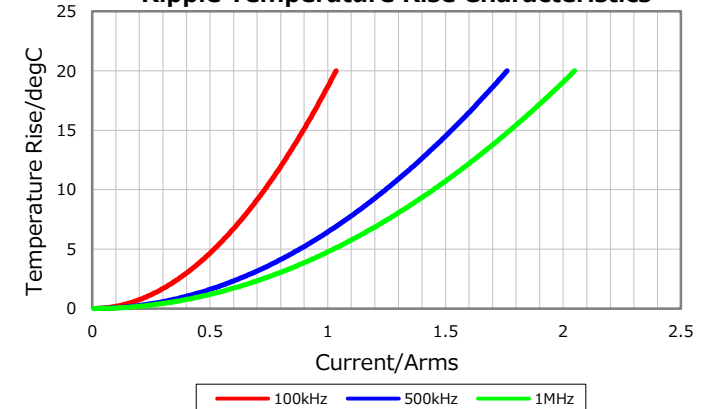

Characterization Sheet (Multilayer Ceramic Chip Capacitors)



All specifications are subject to change without notice.

April 6, 2016