

Rev	AWO #	Description	Date	Appr
-		RELEASED	6/09/10	

APPROVED: _____
 DATE: _____ TITLE: _____

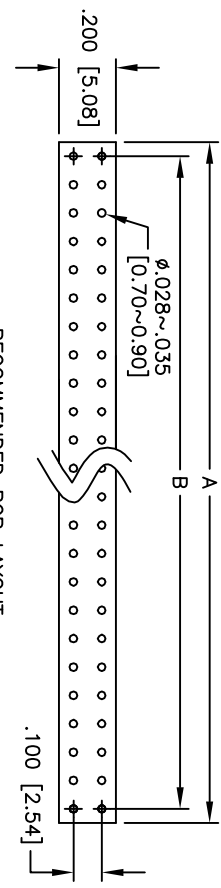

RECOMMENDED PCB LAYOUT

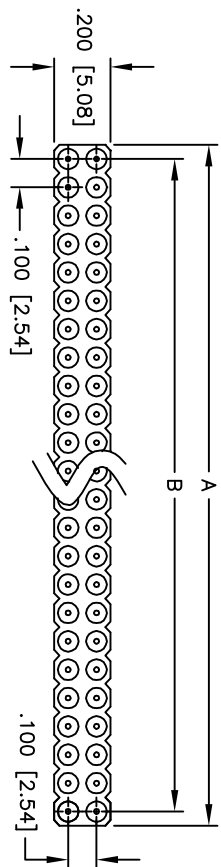
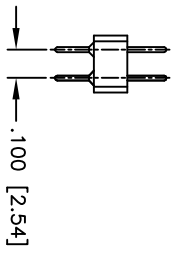
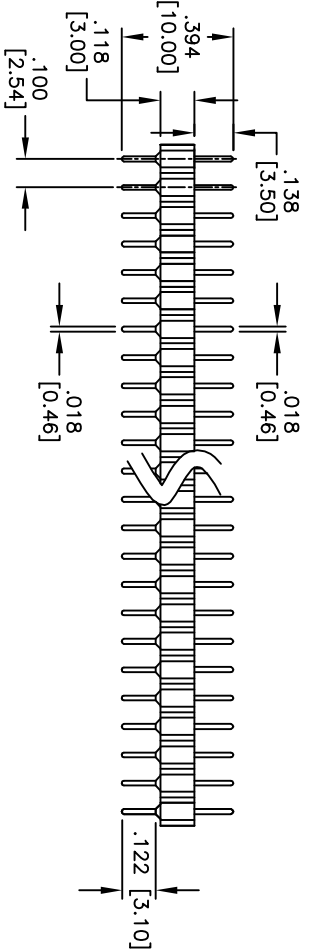

SPECIFICATIONS:
 Material: Polyamide, glass reinforced, rated UL 94V-0
 Insulator color: Black
 Sleeve: Brass
 Plating: Gold flash over Nickel underplate overall.
 Electrical: Current rating: 3 Amp max
 Insulation resistance: 1000 mohms min
 Temperature Rating: Operating temperature: -40°C to +105°C
 Environmental: Lead free, RoHS compliant
 Recommended soldering temp: 260°C for 5 seconds

Positions: 2 thru 80
 A = .100 [2.54] x No. of Positions per Row
 B = .100 [2.54] x No. of Spaces

A

6

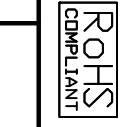

4

UNLESS OTHERWISE SPECIFIED ALL DIMENSIONS ARE IN INCHES [MM]	
TOLERANCES: EXCEPT AS NOTED	
INCHES	HOLDS
.X ± .10	ØX ± .10
.XX ± .020	ØXX ± .015
.XXX ± .015	ØXXX ± .010
APPROVALS	DATE
DRAWN	DY
CHECKED	
APPROVED	
	6/09/10

TITLE		PART NO.		REV.
SCREW MACHINE TERMINAL STRIP, DUAL ROW STRAIGHT, .100" PITCH, GOLD PLATED		MCT-2-XX-1-G		-
909 Rahway Avenue, Union, NJ 07083		SCALE: NTS		SHEET 1 OF 1
Phone: 908-687-5000 Fax: 908-687-5710		REF: S00019C		

1

2

3

5

6