

Features

- Wide 3.6V to 24V Input Voltage Range
- 0.22V FB adjustable LED drive current
- Directly drive 6 Series 1W LED at $V_{IN} \geq 12V$
- Fixed 400KHz Switching Frequency
- Max. 2A Switching Current Capability
- Up to 92% efficiency
- Excellent line and load regulation
- EN PIN TTL shutdown capability & With PWM Dimming Function
- Internal Optimize Power MOSFET
- Built in Soft-Start Function
- Built in Frequency Compensation
- Built in Thermal Shutdown Function
- Built in Current Limit Function
- Available in SOP8 package

Applications

- LED Lighting
- Boost constant current driver
- Monitor LED Backlighting
- 7' to 15' LCD Panels

General Description

The XL6003 regulator is fixed frequency PWM Boost (step-up) LED constant current driver, capable of driving Series 1W LED units with excellent line and load regulation. The regulator is simple to use because it includes internal frequency compensation and a fixed-frequency oscillator so that it requires a minimum number of external components to work.

The XL6003 could directly drive 6 Series 1W LED units at $V_{IN} > 12V$.

The PWM control circuit is able to adjust the duty ratio linearly from 0 to 95%. An enable function, an over current protection function is built inside. An internal compensation block is built in to minimize external component count.



SOIC-8

Figure1. Package Type of XL6003

Pin Configurations

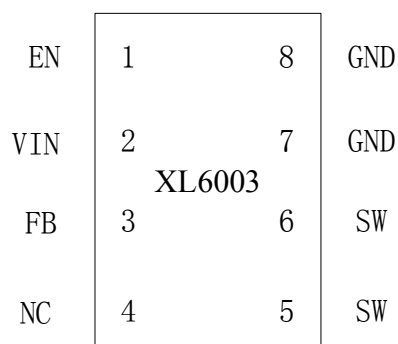

Figure2. Pin Configuration of XL6003 (Top View)

Table 1 Pin Description

Pin Number	Pin Name	Description
1	EN	Enable Pin. Drive EN pin low to turn off the device, drive it high to turn it on. Floating is default high.
2	VIN	Supply Voltage Input Pin. XL6003 operates from a 3.6V to 24V DC voltage. Bypass Vin to GND with a suitably large capacitor to eliminate noise on the input.
3	FB	Feedback Pin (FB). The feedback threshold voltage is 0.22V.
4	NC	No Connected.
5,6	SW	Power Switch Output Pin (SW). Output is the switch node that supplies power to the output.
7,8	GND	Ground Pin.

400KHz 60V 2A Switching Current Boost LED Constant Current Driver **XL6003**

Function Block

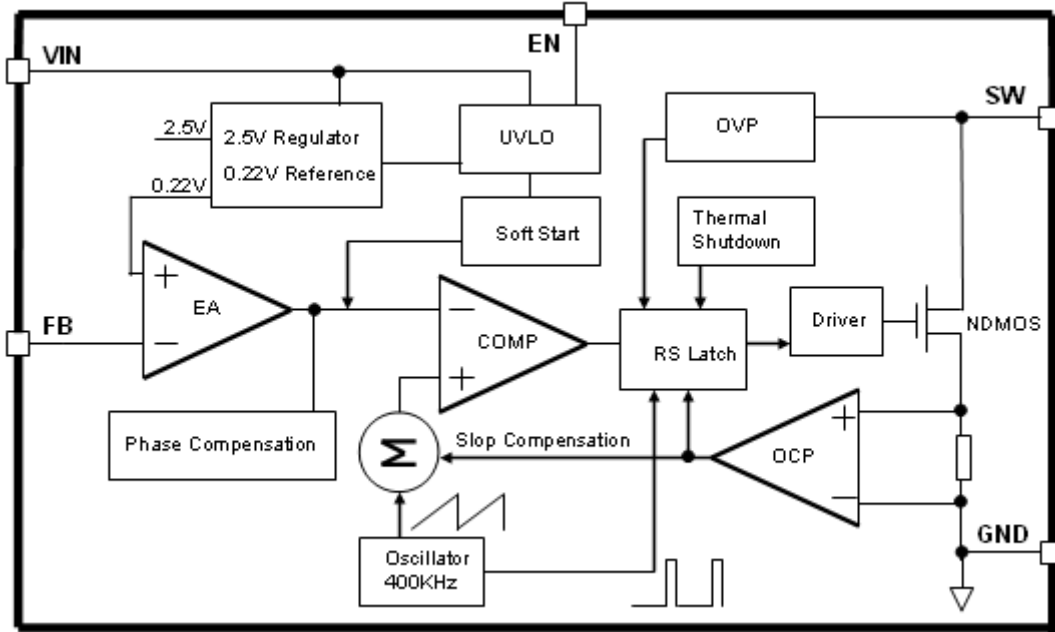

Figure3. Function Block Diagram of XL6003

Typical Application Circuit

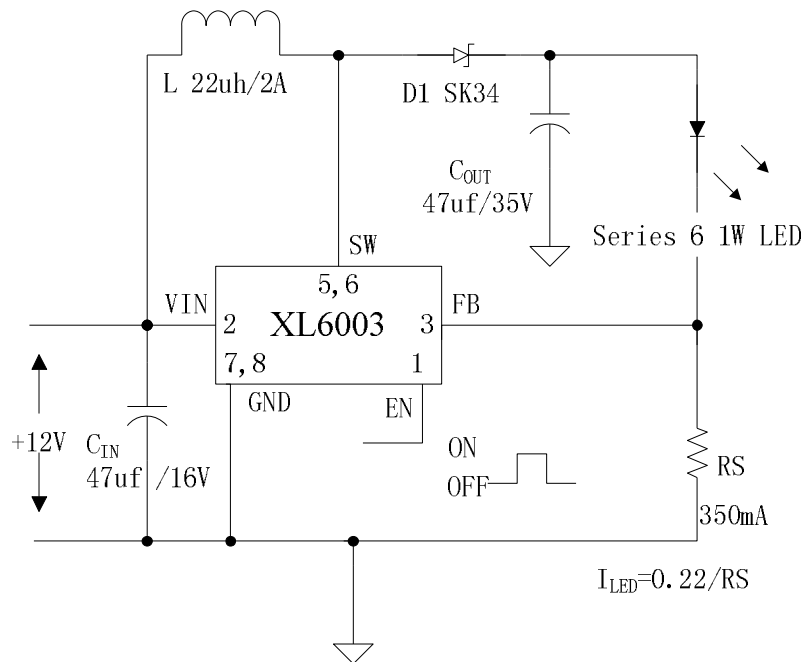

Figure4. XL6003 Typical Application Circuit

400KHz 60V 2A Switching Current Boost LED Constant Current Driver

XL6003

Ordering Information

Order Information	Marking ID	Package Type	Packing Type Supplied As
XL6003E1	XL6003E1	SOP-8L	2500 Units on Tape & Reel

XLSEMI Pb-free products, as designated with “E1” suffix in the par number, are RoHS compliant.

Absolute Maximum Ratings (Note1)

Parameter	Symbol	Value	Unit
Input Voltage	V_{in}	-0.3 to 26	V
Feedback Pin Voltage	V_{FB}	-0.3 to V_{in}	V
EN Pin Voltage	V_{EN}	-0.3 to V_{in}	V
Output Switch Pin Voltage	V_{Output}	-0.3 to 60	V
Power Dissipation	P_D	Internally limited	mW
Thermal Resistance (SOP8) (Junction to Ambient, No Heatsink, Free Air)	R_{JA}	100	°C/W
Operating Junction Temperature	T_J	-40 to 125	°C
Storage Temperature	T_{STG}	-65 to 150	°C
Lead Temperature (Soldering, 10 sec)	T_{LEAD}	260	°C
ESD (HBM)		>2000	V

Note1: Stresses greater than those listed under Maximum Ratings may cause permanent damage to the device. This is a stress rating only and functional operation of the device at these or any other conditions above those indicated in the operation is not implied. Exposure to absolute maximum rating conditions for extended periods may affect reliability.

400KHz 60V 2A Switching Current Boost LED Constant Current Driver

XL6003

XL6003 Electrical Characteristics

$T_a = 25^\circ\text{C}$; unless otherwise specified.

Symbol	Parameter	Test Condition	Min.	Typ.	Max.	Unit
<i>System parameters test circuit figure4</i>						
VFB	Feedback Voltage	$V_{in} = 5\text{V to } 12\text{V}, V_{out}=24\text{V}$ $I_{load}=100\text{mA}$	209	220	231	mV
Efficiency	η	$V_{in}=12\text{V}, V_{out}=24\text{V}$ $I_{out}=0.3\text{A}$	-	92	-	%

Electrical Characteristics (DC Parameters)

$V_{in} = 12\text{V}$, $GND=0\text{V}$, V_{in} & GND parallel connect a $100\mu\text{f}/50\text{V}$ capacitor; $I_{out}=100\text{mA}$, $T_a = 25^\circ\text{C}$; the others floating unless otherwise specified.

Parameters	Symbol	Test Condition	Min.	Typ.	Max.	Unit
Input operation voltage	V_{in}		3.6		24	V
Shutdown Supply Current	I_{STBY}	$V_{EN}=0\text{V}$		70	100	μA
Quiescent Supply Current	I_q	$V_{EN} = 2\text{V},$ $V_{FB} = V_{in}$		2.5	5	mA
Oscillator Frequency	F_{osc}		320	400	480	Khz
Switch Current Limit	I_L	$V_{FB} = 0$		2		A
Output Power NMOS	R_{dson}	$V_{in}=12\text{V},$ $I_{SW}=2\text{A}$		110	120	mohm
EN Pin Threshold	V_{EN}	High (Regulator ON) Low (Regulator OFF)		1.4 0.8		V
EN Pin Input Leakage Current	I_H	$V_{EN} = 2\text{V (ON)}$		3	10	μA
	I_L	$V_{EN} = 0\text{V (OFF)}$		3	10	μA
Max. Duty Cycle	D_{MAX}	$V_{FB}=0\text{V}$		90		%

Schottky Diode Selection Table

Current	Surface Mount	Through Hole	VR (The same as system maximum input voltage)				
			20V	30V	40V	50V	60V
1A		✓	1N5817	1N5818	1N5819		
3A		✓	1N5820	1N5821	1N5822		
		✓	MBR320	MBR330	MBR340	MBR350	MBR360
	✓		SK32	SK33	SK34	SK35	SK36
	✓			30WQ03	30WQ04	30WQ05	
		✓		31DQ03	31DQ04	31DQ05	
		✓	SR302	SR303	SR304	SR305	SR306

Typical System Application for VIN=5V to driver 3 x 1W series LED units

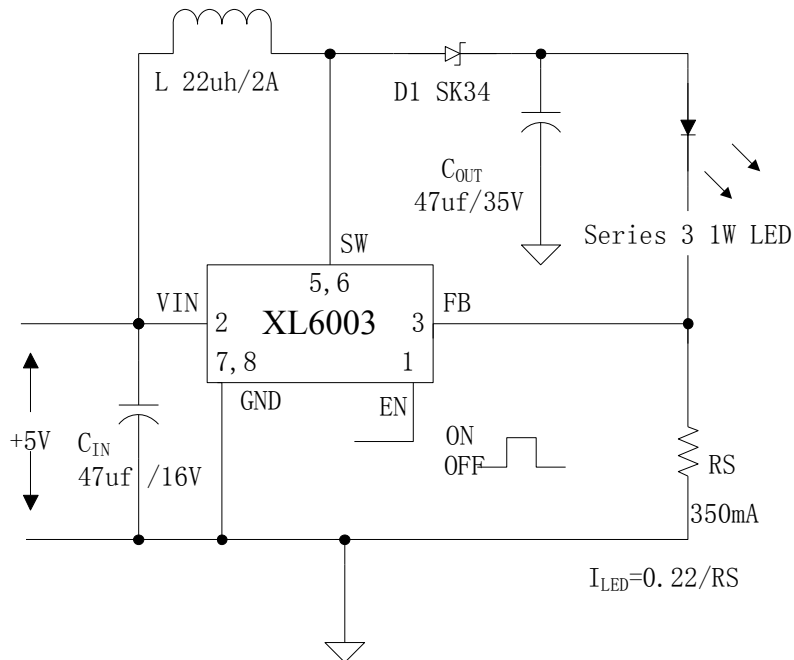

Figure5. XL6003 System Parameters Test Circuit (5V ~ 3 x 1W LED)

400KHz 60V 2A Switching Current Boost LED Constant Current Driver XL6003

Typical System Application for VIN >= 12V to driver 6 x 1W series LED units

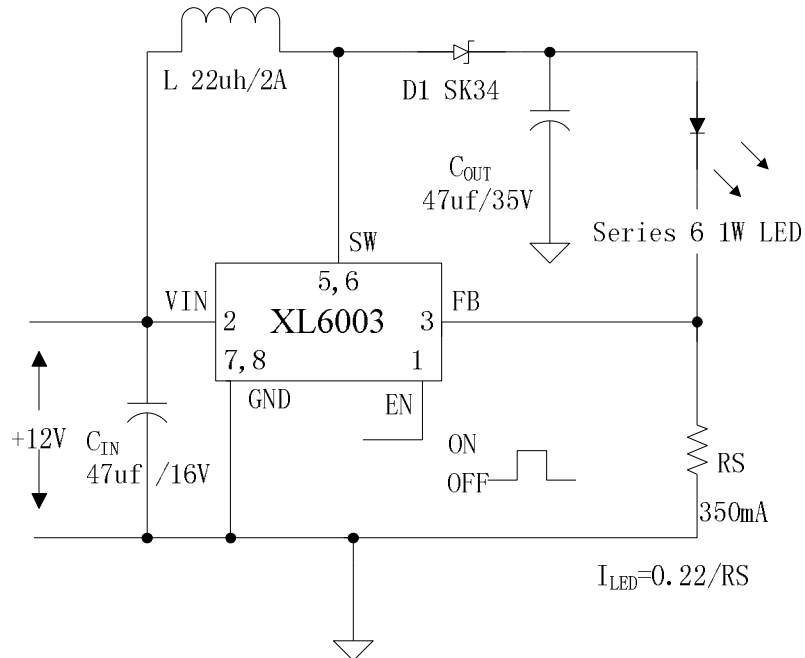

Figure6. XL6003 System Parameters Test Circuit (12V ~ 6 x 1W LED)

Typical System Application for VIN >= 12V to driver 6 series x 28 parallel White LED Array

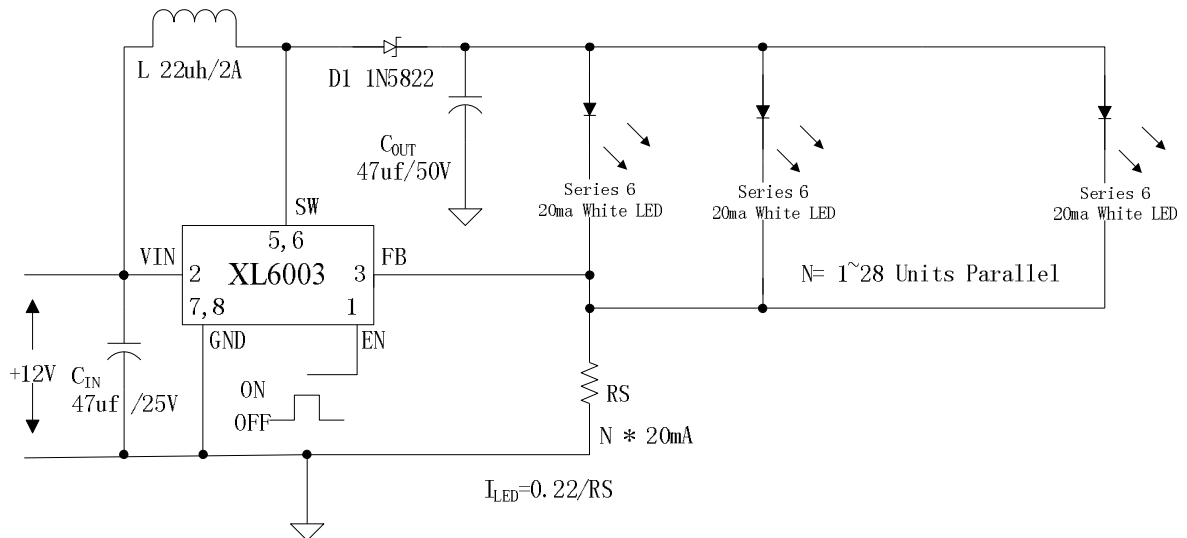

Figure7. XL6003 System Parameters Test Circuit (12V ~ 6 x 28 White LED)

400KHz 60V 2A Switching Current Boost LED Constant Current Driver

XL6003

Typical System Application for SEPIC Buck-Boost LED Driver

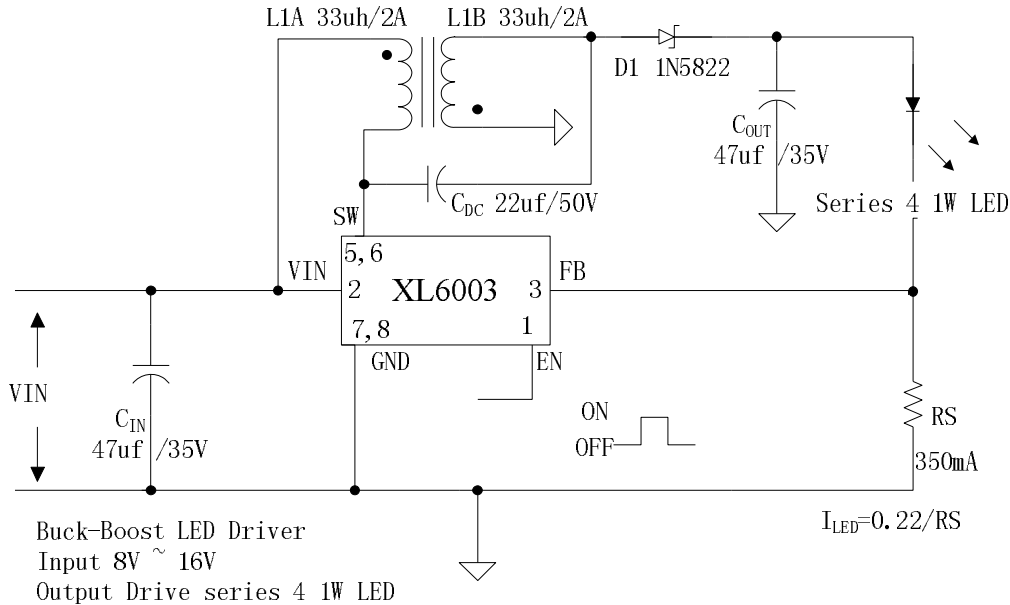

Figure8. XL6003 System Parameters Test Circuit (Buck-Boost LED Driver)

Typical System Application for VIN ≥ 12V to driver 6 x 1W series LED units With Dimming Function

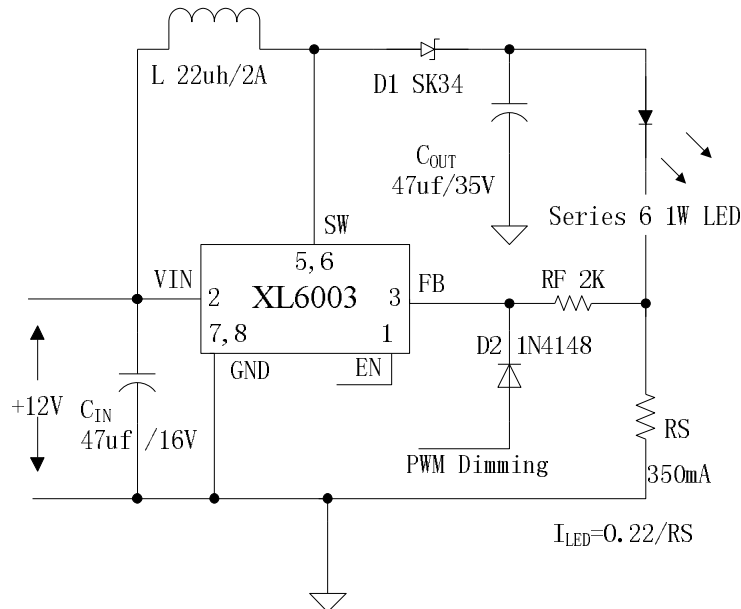

Figure9. XL6003 System Parameters Test Circuit (12V ~ 6 x 1W LED with Dimming Function)

