



PIC18F6520/8520/6620/ 8620/6720/8720

64/80-Pin High-Performance, 256 Kbit to 1 Mbit Enhanced Flash Microcontrollers with A/D

High-Performance RISC CPU:

- C compiler optimized architecture/instruction set:
 - Source code compatible with the PIC16 and PIC17 instruction sets
- Linear program memory addressing to 128 Kbytes
- Linear data memory addressing to 3840 bytes
- 1 Kbyte of data EEPROM
- Up to 10 MIPS operation:
 - DC – 40 MHz osc./clock input
 - 4 MHz – 10 MHz osc./clock input with PLL active
- 16-bit wide instructions, 8-bit wide data path
- Priority levels for interrupts
- 31-level, software accessible hardware stack
- 8 x 8 Single Cycle Hardware Multiplier

External Memory Interface (PIC18F8X20 Devices Only):

- Address capability of up to 2 Mbytes
- 16-bit interface

Peripheral Features:

- High current sink/source 25 mA/25 mA
- Four external interrupt pins
- Timer0 module: 8-bit/16-bit timer/counter
- Timer1 module: 16-bit timer/counter
- Timer2 module: 8-bit timer/counter
- Timer3 module: 16-bit timer/counter
- Timer4 module: 8-bit timer/counter
- Secondary oscillator clock option – Timer1/Timer3
- Five Capture/Compare/PWM (CCP) modules:
 - Capture is 16-bit, max. resolution 6.25 ns (T_{CY}/16)
 - Compare is 16-bit, max. resolution 100 ns (T_{CY})
 - PWM output: PWM resolution is 1 to 10-bit
- Master Synchronous Serial Port (MSSP) module with two modes of operation:
 - 3-wire SPI (supports all 4 SPI modes)
 - I²C™ Master and Slave mode
- Two Addressable USART modules:
 - Supports RS-485 and RS-232
- Parallel Slave Port (PSP) module

Analog Features:

- 10-bit, up to 16-channel Analog-to-Digital Converter (A/D):
 - Conversion available during Sleep
- Programmable 16-level Low-Voltage Detection (LVD) module:
 - Supports interrupt on Low-Voltage Detection
- Programmable Brown-out Reset (PBOR)
- Dual analog comparators:
 - Programmable input/output configuration

Special Microcontroller Features:

- 100,000 erase/write cycle Enhanced Flash program memory typical
- 1,000,000 erase/write cycle Data EEPROM memory typical
- 1 second programming time
- Flash/Data EEPROM Retention: > 40 years
- Self-reprogrammable under software control
- Power-on Reset (POR), Power-up Timer (PWRT) and Oscillator Start-up Timer (OST)
- Watchdog Timer (WDT) with its own On-Chip RC Oscillator for reliable operation
- Programmable code protection
- Power saving Sleep mode
- Selectable oscillator options including:
 - 4X Phase Lock Loop (of primary oscillator)
 - Secondary Oscillator (32 kHz) clock input
- In-Circuit Serial Programming™ (ICSP™) via two pins
- MPLAB® In-Circuit Debug (ICD) via two pins

CMOS Technology:

- Low-power, high-speed Flash technology
- Fully static design
- Wide operating voltage range (2.0V to 5.5V)
- Industrial and Extended temperature ranges

Device	Program Memory		Data Memory		I/O	10-bit A/D (ch)	CCP (PWM)	MSSP		USART	Timers 8-bit/16-bit	Ext Bus	Max Fosc (MHz)
	Bytes	# Single-Word Instructions	SRAM (bytes)	EEPROM (bytes)				SPI	Master I ² C				
PIC18F6520	32K	16384	2048	1024	52	12	5	Y	Y	2	2/3	N	40
PIC18F6620	64K	32768	3840	1024	52	12	5	Y	Y	2	2/3	N	25
PIC18F6720	128K	65536	3840	1024	52	12	5	Y	Y	2	2/3	N	25
PIC18F8520	32K	16384	2048	1024	68	16	5	Y	Y	2	2/3	Y	40
PIC18F8620	64K	32768	3840	1024	68	16	5	Y	Y	2	2/3	Y	25
PIC18F8720	128K	65536	3840	1024	68	16	5	Y	Y	2	2/3	Y	25

PIC18F6520/8520/6620/8620/6720/8720

Pin Diagrams

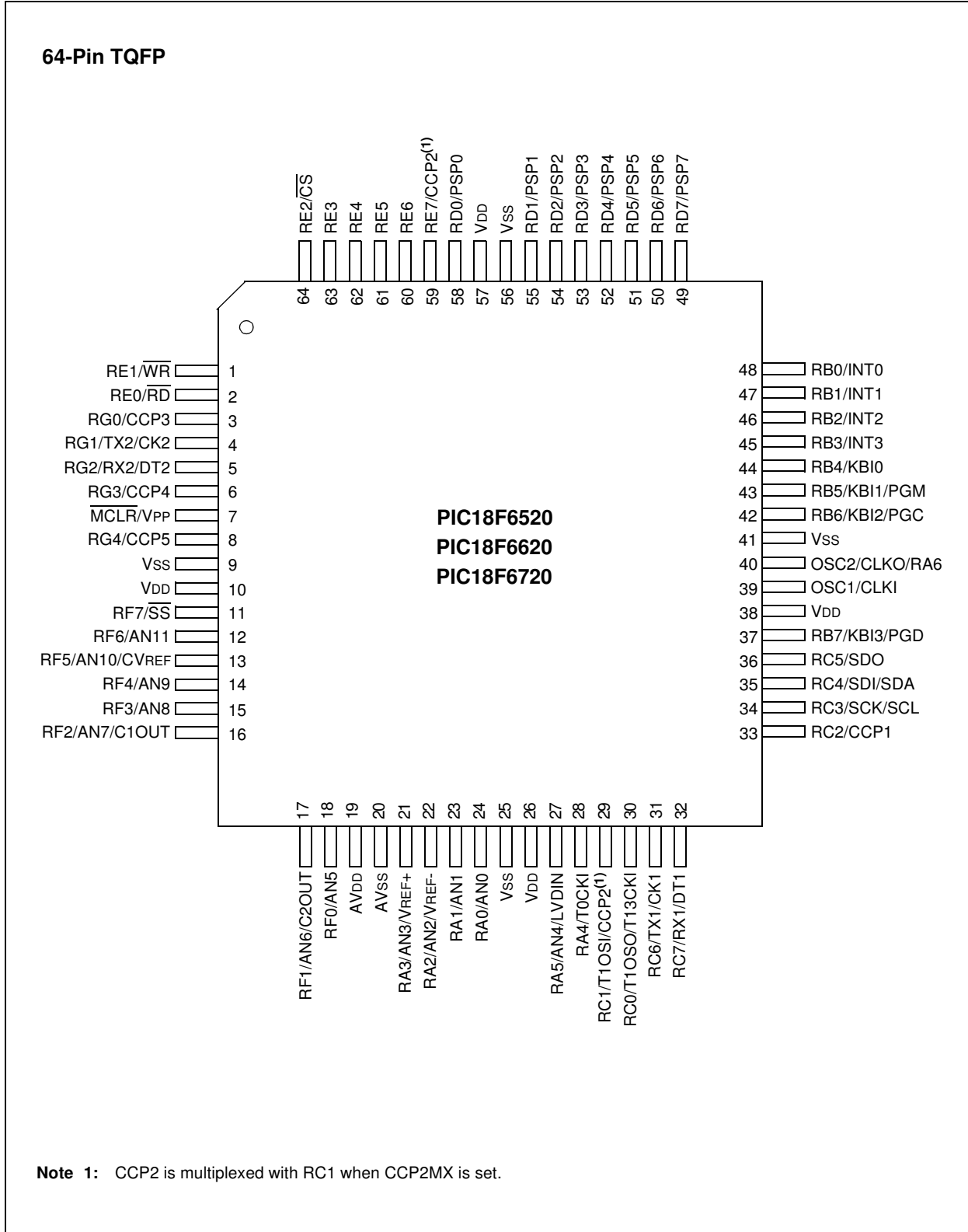

PIC18F6520/8520/6620/8620/6720/8720

Pin Diagrams (Continued)

80-Pin TQFP

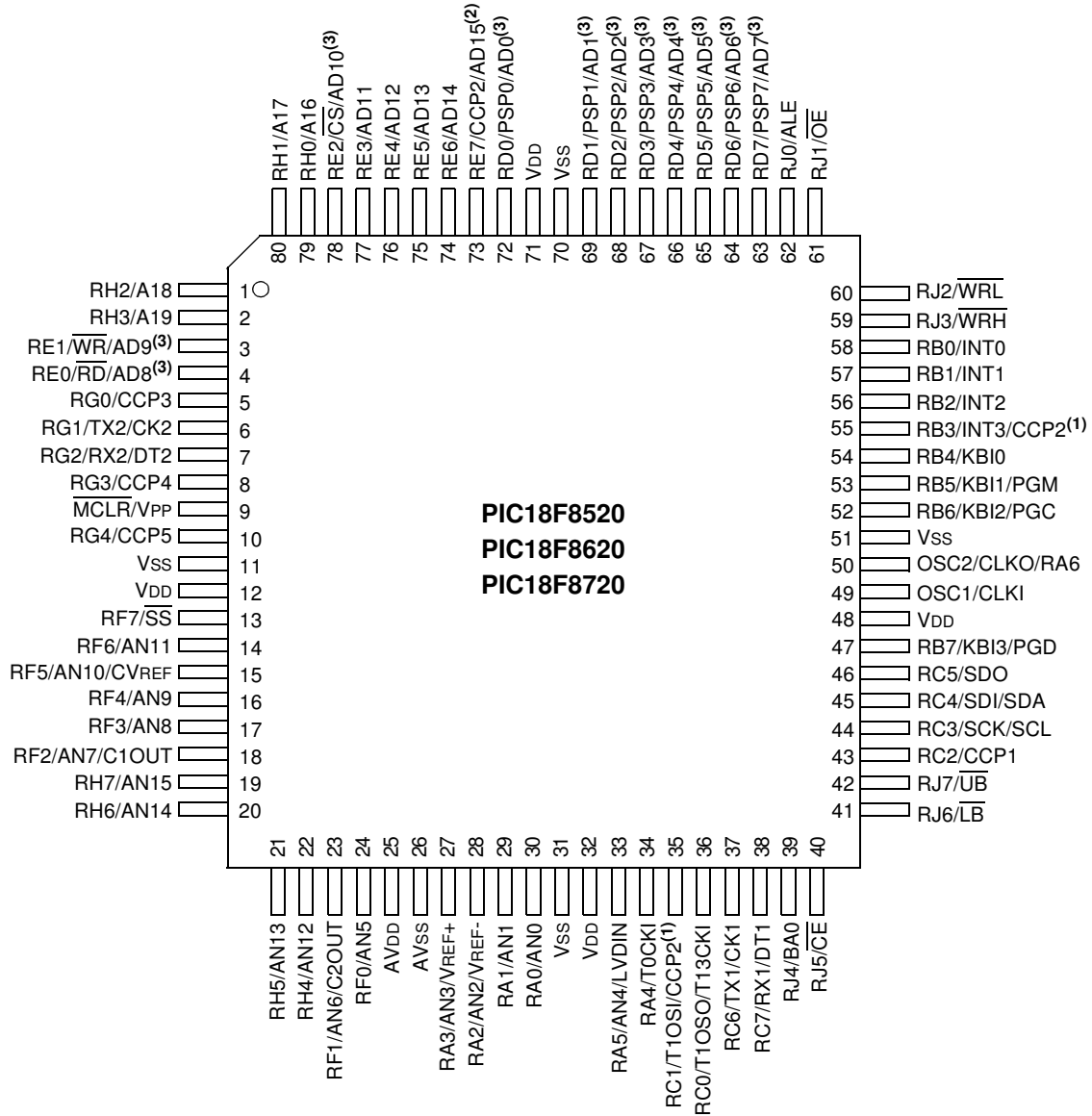

- Note 1:** CCP2 is multiplexed with RC1 when CCP2MX is set.
Note 2: CCP2 is multiplexed by default with RE7 when the device is configured in Microcontroller mode.
Note 3: PSP is available only in Microcontroller mode.

PIC18F6520/8520/6620/8620/6720/8720

Table of Contents

1.0	Device Overview	7
2.0	Oscillator Configurations	21
3.0	Reset	29
4.0	Memory Organization	39
5.0	Flash Program Memory	61
6.0	External Memory Interface	71
7.0	Data EEPROM Memory	79
8.0	8 X 8 Hardware Multiplier	85
9.0	Interrupts	87
10.0	I/O Ports	103
11.0	Timer0 Module	131
12.0	Timer1 Module	135
13.0	Timer2 Module	141
14.0	Timer3 Module	143
15.0	Timer4 Module	147
16.0	Capture/Compare/PWM (CCP) Modules	149
17.0	Master Synchronous Serial Port (MSSP) Module	157
18.0	Addressable Universal Synchronous Asynchronous Receiver Transmitter (USART)	197
19.0	10-Bit Analog-to-Digital Converter (A/D) Module	213
20.0	Comparator Module	223
21.0	Comparator Voltage Reference Module	229
22.0	Low-Voltage Detect	233
23.0	Special Features of the CPU	239
24.0	Instruction Set Summary	259
25.0	Development Support	301
26.0	Electrical Characteristics	305
27.0	DC and AC Characteristics Graphs and Tables	341
28.0	Packaging Information	355
	Appendix A: Revision History	361
	Appendix B: Device Differences	361
	Appendix C: Conversion Considerations	362
	Appendix D: Migration from Mid-range to Enhanced Devices	362
	Appendix E: Migration from High-end to Enhanced Devices	363
	The Microchip Web Site	375
	Customer Change Notification Service	375
	Customer Support	375
	Reader Response	376
	PIC18F6520/8520/6620/8620/6720/8720 Product Identification System	377

TO OUR VALUED CUSTOMERS

It is our intention to provide our valued customers with the best documentation possible to ensure successful use of your Microchip products. To this end, we will continue to improve our publications to better suit your needs. Our publications will be refined and enhanced as new volumes and updates are introduced.

If you have any questions or comments regarding this publication, please contact the Marketing Communications Department via E-mail at docerrors@microchip.com or fax the **Reader Response Form** in the back of this data sheet to (480) 792-4150. We welcome your feedback.

Most Current Data Sheet

To obtain the most up-to-date version of this data sheet, please register at our Worldwide Web site at:

<http://www.microchip.com>

You can determine the version of a data sheet by examining its literature number found on the bottom outside corner of any page. The last character of the literature number is the version number, (e.g., DS30000A is version A of document DS30000).

Errata

An errata sheet, describing minor operational differences from the data sheet and recommended workarounds, may exist for current devices. As device/documentation issues become known to us, we will publish an errata sheet. The errata will specify the revision of silicon and revision of document to which it applies.

To determine if an errata sheet exists for a particular device, please check with one of the following:

- Microchip's Worldwide Web site; <http://www.microchip.com>
- Your local Microchip sales office (see last page)

When contacting a sales office, please specify which device, revision of silicon and data sheet (include literature number) you are using.

Customer Notification System

Register on our web site at www.microchip.com to receive the most current information on all of our products.

PIC18F6520/8520/6620/8620/6720/8720

NOTES:

PIC18F6520/8520/6620/8620/6720/8720

1.0 DEVICE OVERVIEW

This document contains device specific information for the following devices:

- PIC18F6520
- PIC18F8520
- PIC18F6620
- PIC18F8620
- PIC18F6720
- PIC18F8720

This family offers the same advantages of all PIC18 microcontrollers – namely, high computational performance at an economical price – with the addition of high endurance Enhanced Flash program memory. The PIC18FXX20 family also provides an enhanced range of program memory options and versatile analog features that make it ideal for complex, high-performance applications.

1.1 Key Features

1.1.1 EXPANDED MEMORY

The PIC18FXX20 family introduces the widest range of on-chip, Enhanced Flash program memory available on PIC® microcontrollers – up to 128 Kbyte (or 65,536 words), the largest ever offered by Microchip. For users with more modest code requirements, the family also includes members with 32 Kbyte or 64 Kbyte.

Other memory features are:

- **Data RAM and Data EEPROM:** The PIC18FXX20 family also provides plenty of room for application data. Depending on the device, either 2048 or 3840 bytes of data RAM are available. All devices have 1024 bytes of data EEPROM for long-term retention of nonvolatile data.
- **Memory Endurance:** The Enhanced Flash cells for both program memory and data EEPROM are rated to last for many thousands of erase/write cycles – up to 100,000 for program memory and 1,000,000 for EEPROM. Data retention without refresh is conservatively estimated to be greater than 40 years.

1.1.2 EXTERNAL MEMORY INTERFACE

In the event that 128 Kbytes of program memory is inadequate for an application, the PIC18F8X20 members of the family also implement an External Memory Interface. This allows the controller's internal program counter to address a memory space of up to 2 Mbytes, permitting a level of data access that few 8-bit devices can claim.

With the addition of new operating modes, the External Memory Interface offers many new options, including:

- Operating the microcontroller entirely from external memory
- Using combinations of on-chip and external memory, up to the 2-Mbyte limit
- Using external Flash memory for reprogrammable application code, or large data tables
- Using external RAM devices for storing large amounts of variable data

1.1.3 EASY MIGRATION

Regardless of the memory size, all devices share the same rich set of peripherals, allowing for a smooth migration path as applications grow and evolve.

The consistent pinout scheme used throughout the entire family also aids in migrating to the next larger device. This is true when moving between the 64-pin members, between the 80-pin members, or even jumping from 64-pin to 80-pin devices.

1.1.4 OTHER SPECIAL FEATURES

- **Communications:** The PIC18FXX20 family incorporates a range of serial communications peripherals, including 2 independent USARTs and a Master SSP module, capable of both SPI and I²C (Master and Slave) modes of operation. For PIC18F8X20 devices, one of the general purpose I/O ports can be reconfigured as an 8-bit Parallel Slave Port for direct processor-to-processor communications.
- **CCP Modules:** All devices in the family incorporate five Capture/Compare/PWM modules to maximize flexibility in control applications. Up to four different time bases may be used to perform several different operations at once.
- **Analog Features:** All devices in the family feature 10-bit A/D converters, with up to 16 input channels, as well as the ability to perform conversions during Sleep mode. Also included are dual analog comparators with programmable input and output configuration, a programmable Low-Voltage Detect module and a programmable Brown-out Reset module.
- **Self-programmability:** These devices can write to their own program memory spaces under internal software control. By using a bootloader routine located in the protected Boot Block at the top of program memory, it becomes possible to create an application that can update itself in the field.

PIC18F6520/8520/6620/8620/6720/8720

1.2 Details on Individual Family Members

The PIC18FXX20 devices are available in 64-pin and 80-pin packages. They are differentiated from each other in five ways:

- Flash program memory (32 Kbytes for PIC18FX520 devices, 64 Kbytes for PIC18FX620 devices and 128 Kbytes for PIC18FX720 devices)
- Data RAM (2048 bytes for PIC18FX520 devices, 3840 bytes for PIC18FX620 and PIC18FX720 devices)

- A/D channels (12 for PIC18F6X20 devices, 16 for PIC18F8X20)
- I/O pins (52 on PIC18F6X20 devices, 68 on PIC18F8X20)
- External program memory interface (present only on PIC18F8X20 devices)

All other features for devices in the PIC18FXX20 family are identical. These are summarized in Table 1-1.

Block diagrams of the PIC18F6X20 and PIC18F8X20 devices are provided in Figure 1-1 and Figure 1-2, respectively. The pinouts for these device families are listed in Table 1-2.

TABLE 1-1: PIC18FXX20 DEVICE FEATURES

Features	PIC18F6520	PIC18F6620	PIC18F6720	PIC18F8520	PIC18F8620	PIC18F8720
Operating Frequency	DC – 40 MHz	DC – 25 MHz	DC – 25 MHz	DC – 40 MHz	DC – 25 MHz	DC – 25 MHz
Program Memory (Bytes)	32K	64K	128K	32K	64K	128K
Program Memory (Instructions)	16384	32768	65536	16384	32768	65536
Data Memory (Bytes)	2048	3840	3840	2048	3840	3840
Data EEPROM Memory (Bytes)	1024	1024	1024	1024	1024	1024
External Memory Interface	No	No	No	Yes	Yes	Yes
Interrupt Sources	17	17	17	18	18	18
I/O Ports	Ports A, B, C, D, E, F, G	Ports A, B, C, D, E, F, G	Ports A, B, C, D, E, F, G	Ports A, B, C, D, E, F, G, H, J	Ports A, B, C, D, E, F, G, H, J	Ports A, B, C, D, E, F, G, H, J
Timers	5	5	5	5	5	5
Capture/Compare/PWM Modules	5	5	5	5	5	5
Serial Communications	MSSP, Addressable USART (2)	MSSP, Addressable USART (2)	MSSP, Addressable USART (2)	MSSP, Addressable USART (2)	MSSP, Addressable USART (2)	MSSP, Addressable USART (2)
Parallel Communications	PSP	PSP	PSP	PSP	PSP	PSP
10-bit Analog-to-Digital Module	12 input channels	12 input channels	12 input channels	16 input channels	16 input channels	16 input channels
Resets (and Delays)	POR, BOR, RESET Instruction, Stack Full, Stack Underflow (PWRT, OST)	POR, BOR, RESET Instruction, Stack Full, Stack Underflow (PWRT, OST)	POR, BOR, RESET Instruction, Stack Full, Stack Underflow (PWRT, OST)	POR, BOR, RESET Instruction, Stack Full, Stack Underflow (PWRT, OST)	POR, BOR, RESET Instruction, Stack Full, Stack Underflow (PWRT, OST)	POR, BOR, RESET Instruction, Stack Full, Stack Underflow (PWRT, OST)
Programmable Low-Voltage Detect	Yes	Yes	Yes	Yes	Yes	Yes
Programmable Brown-out Reset	Yes	Yes	Yes	Yes	Yes	Yes
Instruction Set	77 Instructions	77 Instructions	77 Instructions	77 Instructions	77 Instructions	77 Instructions
Package	64-pin TQFP	64-pin TQFP	64-pin TQFP	80-pin TQFP	80-pin TQFP	80-pin TQFP

PIC18F6520/8520/6620/8620/6720/8720

FIGURE 1-1: PIC18F6X20 BLOCK DIAGRAM

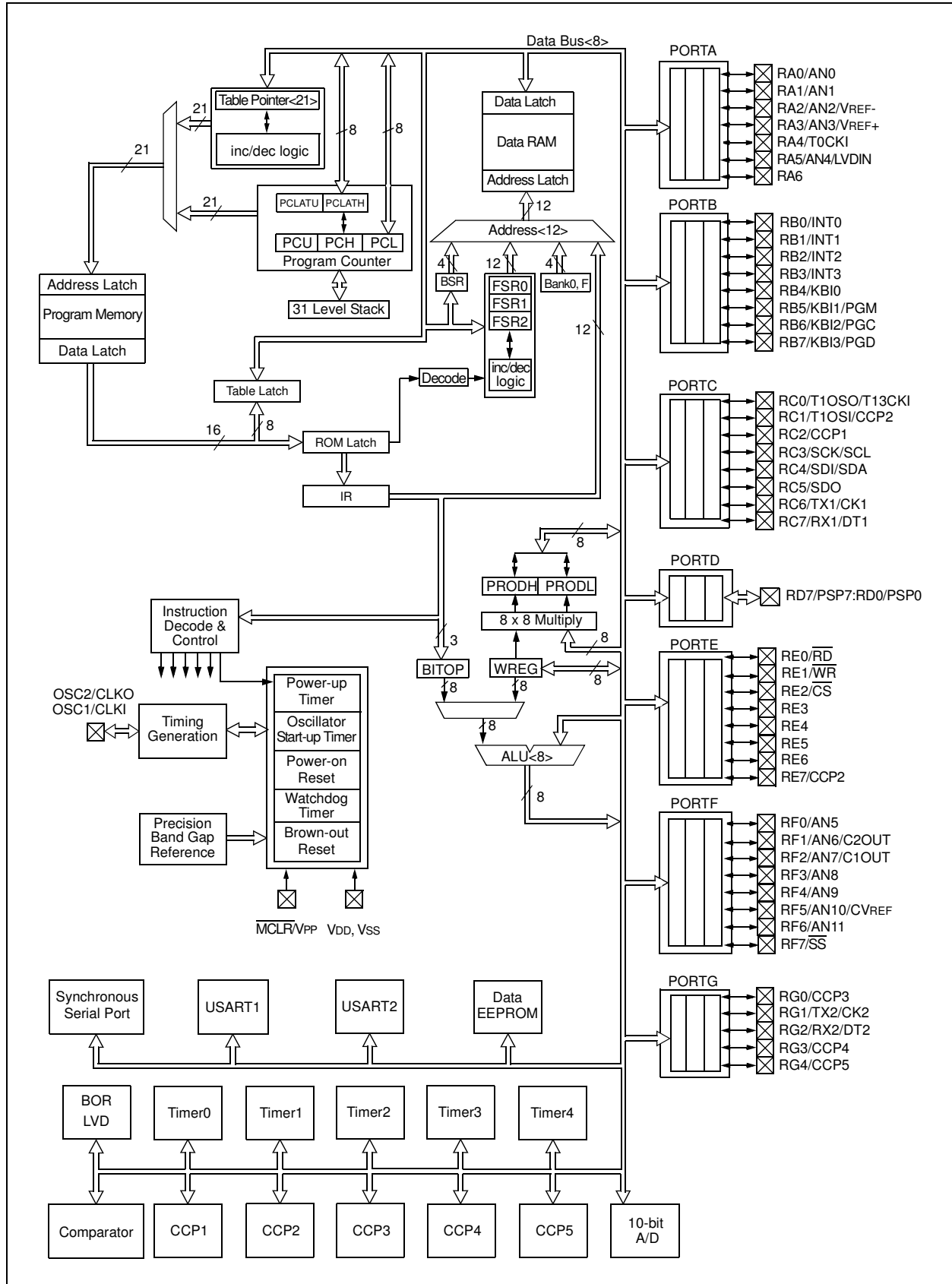

PIC18F6520/8520/6620/8620/6720/8720

FIGURE 1-2: PIC18F8X20 BLOCK DIAGRAM

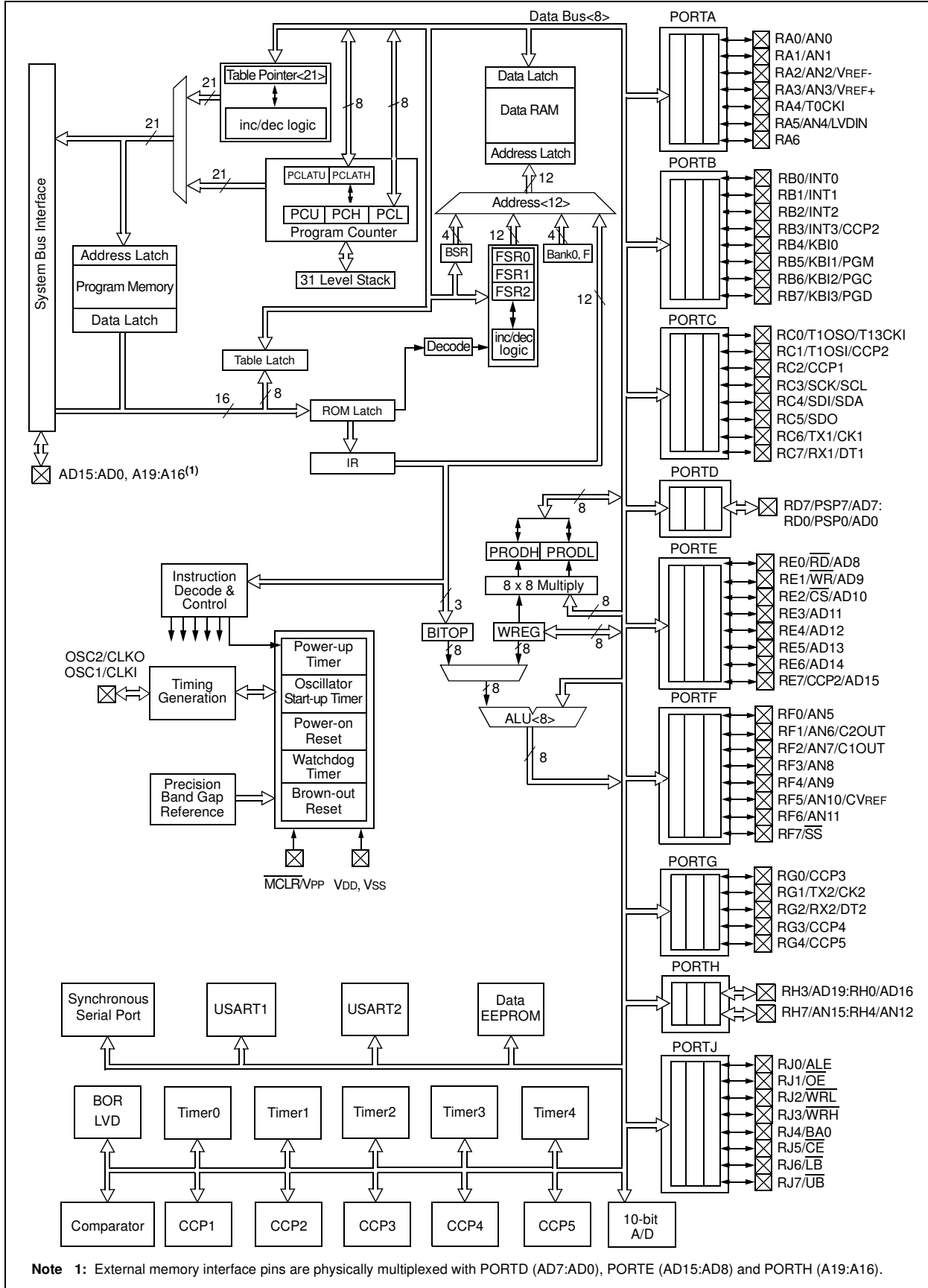

PIC18F6520/8520/6620/8620/6720/8720

TABLE 1-2: PIC18FXX20 PINOUT I/O DESCRIPTIONS

Pin Name	Pin Number		Pin Type	Buffer Type	Description
	PIC18F6X20	PIC18F8X20			
MCLR/VPP MCLR VPP	7	9	I P	ST	Master Clear (input) or programming voltage (output). Master Clear (Reset) input. This pin is an active-low Reset to the device. Programming voltage input.
OSC1/CLKI OSC1 CLKI	39	49	I I	CMOS/ST CMOS	Oscillator crystal or external clock input. Oscillator crystal input or external clock source input. ST buffer when configured in RC mode; otherwise CMOS. External clock source input. Always associated with pin function OSC1 (see OSC1/CLKI, OSC2/CLKO pins).
OSC2/CLKO/RA6 OSC2 CLKO RA6	40	50	O O I/O	— — TTL	Oscillator crystal or clock output. Oscillator crystal output. Connects to crystal or resonator in Crystal Oscillator mode. In RC mode, OSC2 pin outputs CLKO, which has 1/4 the frequency of OSC1 and denotes the instruction cycle rate. General purpose I/O pin.

Legend: TTL = TTL compatible input
 ST = Schmitt Trigger input with CMOS levels
 I = Input
 P = Power
 CMOS = CMOS compatible input or output
 Analog = Analog input
 O = Output
 OD = Open-Drain (no P diode to VDD)

- Note 1:** Alternate assignment for CCP2 when CCP2MX is not selected (all operating modes except Microcontroller).
- 2: Default assignment when CCP2MX is set.
 - 3: External memory interface functions are only available on PIC18F8X20 devices.
 - 4: CCP2 is multiplexed with this pin by default when configured in Microcontroller mode. Otherwise, it is multiplexed with either RB3 or RC1.
 - 5: PORTH and PORTJ are only available on PIC18F8X20 (80-pin) devices.
 - 6: AVDD must be connected to a positive supply and AVSS must be connected to a ground reference for proper operation of the part in user or ICSP modes. See parameter D001A for details.

PIC18F6520/8520/6620/8620/6720/8720

TABLE 1-2: PIC18FXX20 PINOUT I/O DESCRIPTIONS (CONTINUED)

Pin Name	Pin Number		Pin Type	Buffer Type	Description
	PIC18F6X20	PIC18F8X20			
RA0/AN0 RA0 AN0	24	30	I/O I	TTL Analog	PORTA is a bidirectional I/O port. Digital I/O. Analog input 0.
RA1/AN1 RA1 AN1	23	29	I/O I	TTL Analog	Digital I/O. Analog input 1.
RA2/AN2/VREF- RA2 AN2 VREF-	22	28	I/O I I	TTL Analog Analog	Digital I/O. Analog input 2. A/D reference voltage (Low) input.
RA3/AN3/VREF+ RA3 AN3 VREF+	21	27	I/O I I	TTL Analog Analog	Digital I/O. Analog input 3. A/D reference voltage (High) input.
RA4/T0CKI RA4 T0CKI	28	34	I/O I	ST/OD ST	Digital I/O – Open-drain when configured as output. Timer0 external clock input.
RA5/AN4/LVDIN RA5 AN4 LVDIN	27	33	I/O I I	TTL Analog Analog	Digital I/O. Analog input 4. Low-Voltage Detect input.
RA6					See the OSC2/CLKO/RA6 pin.

Legend: TTL = TTL compatible input CMOS = CMOS compatible input or output
ST = Schmitt Trigger input with CMOS levels Analog = Analog input
I = Input O = Output
P = Power OD = Open-Drain (no P diode to VDD)

- Note 1:** Alternate assignment for CCP2 when CCP2MX is not selected (all operating modes except Microcontroller).
- 2:** Default assignment when CCP2MX is set.
 - 3:** External memory interface functions are only available on PIC18F8X20 devices.
 - 4:** CCP2 is multiplexed with this pin by default when configured in Microcontroller mode. Otherwise, it is multiplexed with either RB3 or RC1.
 - 5:** PORTH and PORTJ are only available on PIC18F8X20 (80-pin) devices.
 - 6:** AVDD must be connected to a positive supply and AVSS must be connected to a ground reference for proper operation of the part in user or ICSP modes. See parameter D001A for details.

PIC18F6520/8520/6620/8620/6720/8720

TABLE 1-2: PIC18FXX20 PINOUT I/O DESCRIPTIONS (CONTINUED)

Pin Name	Pin Number		Pin Type	Buffer Type	Description
	PIC18F6X20	PIC18F8X20			
RB0/INT0 RB0 INT0	48	58	I/O I	TTL ST	PORTB is a bidirectional I/O port. PORTB can be software programmed for internal weak pull-ups on all inputs. Digital I/O. External interrupt 0.
RB1/INT1 RB1 INT1	47	57	I/O I	TTL ST	Digital I/O. External interrupt 1.
RB2/INT2 RB2 INT2	46	56	I/O I	TTL ST	Digital I/O. External interrupt 2.
RB3/INT3/CCP2 RB3 INT3 CCP2 ⁽¹⁾	45	55	I/O I/O I/O	TTL ST ST	Digital I/O. External interrupt 3. Capture2 input, Compare2 output, PWM2 output.
RB4/KBI0 RB4 KBI0	44	54	I/O I	TTL ST	Digital I/O. Interrupt-on-change pin.
RB5/KBI1/PGM RB5 KBI1 PGM	43	53	I/O I I/O	TTL ST ST	Digital I/O. Interrupt-on-change pin. Low-Voltage ICSP Programming enable pin.
RB6/KBI2/PGC RB6 KBI2 PGC	42	52	I/O I I/O	TTL ST ST	Digital I/O. Interrupt-on-change pin. In-Circuit Debugger and ICSP programming clock.
RB7/KBI3/PGD RB7 KBI3 PGD	37	47	I/O I/O	TTL ST	Digital I/O. Interrupt-on-change pin. In-Circuit Debugger and ICSP programming data.

Legend: TTL = TTL compatible input CMOS = CMOS compatible input or output
 ST = Schmitt Trigger input with CMOS levels Analog = Analog input
 I = Input O = Output
 P = Power OD = Open-Drain (no P diode to VDD)

- Note 1:** Alternate assignment for CCP2 when CCP2MX is not selected (all operating modes except Microcontroller).
- 2:** Default assignment when CCP2MX is set.
- 3:** External memory interface functions are only available on PIC18F8X20 devices.
- 4:** CCP2 is multiplexed with this pin by default when configured in Microcontroller mode. Otherwise, it is multiplexed with either RB3 or RC1.
- 5:** PORTH and PORTJ are only available on PIC18F8X20 (80-pin) devices.
- 6:** AVDD must be connected to a positive supply and AVSS must be connected to a ground reference for proper operation of the part in user or ICSP modes. See parameter D001A for details.

PIC18F6520/8520/6620/8620/6720/8720

TABLE 1-2: PIC18FXX20 PINOUT I/O DESCRIPTIONS (CONTINUED)

Pin Name	Pin Number		Pin Type	Buffer Type	Description
	PIC18F6X20	PIC18F8X20			
RC0/T1OSO/T13CKI RC0 T1OSO T13CKI	30	36	I/O O I	ST — ST	PORTC is a bidirectional I/O port. Digital I/O. Timer1 oscillator output. Timer1/Timer3 external clock input.
RC1/T1OSI/CCP2 RC1 T1OSI CCP2 ⁽²⁾	29	35	I/O I I/O	ST CMOS ST	Digital I/O. Timer1 oscillator input. Capture2 input/Compare2 output/ PWM2 output.
RC2/CCP1 RC2 CCP1	33	43	I/O I/O	ST ST	Digital I/O. Capture1 input/Compare1 output/ PWM1 output.
RC3/SCK/SCL RC3 SCK SCL	34	44	I/O I/O I/O	ST ST ST	Digital I/O. Synchronous serial clock input/output for SPI mode. Synchronous serial clock input/output for I ² C mode.
RC4/SDI/SDA RC4 SDI SDA	35	45	I/O I I/O	ST ST ST	Digital I/O. SPI data in. I ² C data I/O.
RC5/SDO RC5 SDO	36	46	I/O O	ST —	Digital I/O. SPI data out.
RC6/TX1/CK1 RC6 TX1 CK1	31	37	I/O O I/O	ST — ST	Digital I/O. USART 1 asynchronous transmit. USART 1 synchronous clock (see RX1/DT1).
RC7/RX1/DT1 RC7 RX1 DT1	32	38	I/O I I/O	ST ST ST	Digital I/O. USART 1 asynchronous receive. USART 1 synchronous data (see TX1/CK1).

Legend: TTL = TTL compatible input
ST = Schmitt Trigger input with CMOS levels
I = Input
P = Power
CMOS = CMOS compatible input or output
Analog = Analog input
O = Output
OD = Open-Drain (no P diode to VDD)

- Note 1:** Alternate assignment for CCP2 when CCP2MX is not selected (all operating modes except Microcontroller).
- 2:** Default assignment when CCP2MX is set.
- 3:** External memory interface functions are only available on PIC18F8X20 devices.
- 4:** CCP2 is multiplexed with this pin by default when configured in Microcontroller mode. Otherwise, it is multiplexed with either RB3 or RC1.
- 5:** PORTH and PORTJ are only available on PIC18F8X20 (80-pin) devices.
- 6:** AVDD must be connected to a positive supply and AVSS must be connected to a ground reference for proper operation of the part in user or ICSP modes. See parameter D001A for details.

PIC18F6520/8520/6620/8620/6720/8720

TABLE 1-2: PIC18FXX20 PINOUT I/O DESCRIPTIONS (CONTINUED)

Pin Name	Pin Number		Pin Type	Buffer Type	Description
	PIC18F6X20	PIC18F8X20			
RD0/PSP0/AD0 RD0 PSP0 AD0 ⁽³⁾	58	72	I/O I/O I/O	ST TTL TTL	PORTD is a bidirectional I/O port. These pins have TTL input buffers when external memory is enabled. Digital I/O. Parallel Slave Port data. External memory address/data 0.
RD1/PSP1/AD1 RD1 PSP1 AD1 ⁽³⁾	55	69	I/O I/O I/O	ST TTL TTL	Digital I/O. Parallel Slave Port data. External memory address/data 1.
RD2/PSP2/AD2 RD2 PSP2 AD2 ⁽³⁾	54	68	I/O I/O I/O	ST TTL TTL	Digital I/O. Parallel Slave Port data. External memory address/data 2.
RD3/PSP3/AD3 RD3 PSP3 AD3 ⁽³⁾	53	67	I/O I/O I/O	ST TTL TTL	Digital I/O. Parallel Slave Port data. External memory address/data 3.
RD4/PSP4/AD4 RD4 PSP4 AD4 ⁽³⁾	52	66	I/O I/O I/O	ST TTL TTL	Digital I/O. Parallel Slave Port data. External memory address/data 4.
RD5/PSP5/AD5 RD5 PSP5 AD5 ⁽³⁾	51	65	I/O I/O I/O	ST TTL TTL	Digital I/O. Parallel Slave Port data. External memory address/data 5.
RD6/PSP6/AD6 RD6 PSP6 AD6 ⁽³⁾	50	64	I/O I/O I/O	ST TTL TTL	Digital I/O. Parallel Slave Port data. External memory address/data 6.
RD7/PSP7/AD7 RD7 PSP7 AD7 ⁽³⁾	49	63	I/O I/O I/O	ST TTL TTL	Digital I/O. Parallel Slave Port data. External memory address/data 7.

Legend: TTL = TTL compatible input CMOS = CMOS compatible input or output
 ST = Schmitt Trigger input with CMOS levels Analog = Analog input
 I = Input O = Output
 P = Power OD = Open-Drain (no P diode to VDD)

- Note 1:** Alternate assignment for CCP2 when CCP2MX is not selected (all operating modes except Microcontroller).
- 2:** Default assignment when CCP2MX is set.
- 3:** External memory interface functions are only available on PIC18F8X20 devices.
- 4:** CCP2 is multiplexed with this pin by default when configured in Microcontroller mode. Otherwise, it is multiplexed with either RB3 or RC1.
- 5:** PORTH and PORTJ are only available on PIC18F8X20 (80-pin) devices.
- 6:** AVDD must be connected to a positive supply and AVSS must be connected to a ground reference for proper operation of the part in user or ICSP modes. See parameter D001A for details.

PIC18F6520/8520/6620/8620/6720/8720

TABLE 1-2: PIC18FXX20 PINOUT I/O DESCRIPTIONS (CONTINUED)

Pin Name	Pin Number		Pin Type	Buffer Type	Description
	PIC18F6X20	PIC18F8X20			
RE0/ $\overline{\text{RD}}$ /AD8 RE0 RD AD8 ⁽³⁾	2	4	I/O I I/O	ST TTL TTL	PORTE is a bidirectional I/O port. Digital I/O. Read control for Parallel Slave Port (see $\overline{\text{WR}}$ and $\overline{\text{CS}}$ pins). External memory address/data 8.
RE1/ $\overline{\text{WR}}$ /AD9 RE1 WR AD9 ⁽³⁾	1	3	I/O I I/O	ST TTL TTL	Digital I/O. Write control for Parallel Slave Port (see $\overline{\text{CS}}$ and $\overline{\text{RD}}$ pins). External memory address/data 9.
RE2/ $\overline{\text{CS}}$ /AD10 RE2 $\overline{\text{CS}}$ AD10 ⁽³⁾	64	78	I/O I I/O	ST TTL TTL	Digital I/O. Chip select control for Parallel Slave Port (see $\overline{\text{RD}}$ and $\overline{\text{WR}}$). External memory address/data 10.
RE3/AD11 RE3 AD11 ⁽³⁾	63	77	I/O I/O	ST TTL	Digital I/O. External memory address/data 11.
RE4/AD12 RE4 AD12	62	76	I/O I/O	ST TTL	Digital I/O. External memory address/data 12.
RE5/AD13 RE5 AD13 ⁽³⁾	61	75	I/O I/O	ST TTL	Digital I/O. External memory address/data 13.
RE6/AD14 RE6 AD14 ⁽³⁾	60	74	I/O I/O	ST TTL	Digital I/O. External memory address/data 14.
RE7/CCP2/AD15 RE7 CCP2 ^(1,4) AD15 ⁽³⁾	59	73	I/O I/O I/O	ST ST TTL	Digital I/O. Capture2 input/Compare2 output/ PWM2 output. External memory address/data 15.

Legend: TTL = TTL compatible input CMOS = CMOS compatible input or output
 ST = Schmitt Trigger input with CMOS levels Analog = Analog input
 I = Input O = Output
 P = Power OD = Open-Drain (no P diode to VDD)

- Note 1:** Alternate assignment for CCP2 when CCP2MX is not selected (all operating modes except Microcontroller).
- 2:** Default assignment when CCP2MX is set.
- 3:** External memory interface functions are only available on PIC18F8X20 devices.
- 4:** CCP2 is multiplexed with this pin by default when configured in Microcontroller mode. Otherwise, it is multiplexed with either RB3 or RC1.
- 5:** PORTH and PORTJ are only available on PIC18F8X20 (80-pin) devices.
- 6:** AVDD must be connected to a positive supply and AVSS must be connected to a ground reference for proper operation of the part in user or ICSP modes. See parameter D001A for details.

PIC18F6520/8520/6620/8620/6720/8720

TABLE 1-2: PIC18FXX20 PINOUT I/O DESCRIPTIONS (CONTINUED)

Pin Name	Pin Number		Pin Type	Buffer Type	Description
	PIC18F6X20	PIC18F8X20			
RF0/AN5	18	24	I/O	ST	PORTF is a bidirectional I/O port. Digital I/O. Analog input 5.
RF0			I	Analog	
AN5					
RF1/AN6/C2OUT	17	23	I/O	ST	Digital I/O. Analog input 6. Comparator 2 output.
RF1			I	Analog	
AN6 C2OUT				O ST	
RF2/AN7/C1OUT	16	18	I/O	ST	Digital I/O. Analog input 7. Comparator 1 output.
RF2			I	Analog	
AN7 C1OUT				O ST	
RF3/AN8	15	17	I/O	ST	Digital I/O. Analog input 8.
RF1			I	Analog	
AN8					
RF4/AN9	14	16	I/O	ST	Digital I/O. Analog input 9.
RF1			I	Analog	
AN9					
RF5/AN10/CVREF	13	15	I/O	ST	Digital I/O. Analog input 10. Comparator VREF output.
RF1			I	Analog	
AN10 CVREF				O Analog	
RF6/AN11	12	14	I/O	ST	Digital I/O. Analog input 11.
RF6			I	Analog	
AN11					
RF7/ \overline{SS}	11	13	I/O	ST	Digital I/O. SPI slave select input.
RF7			I	TTL	
\overline{SS}					

Legend: TTL = TTL compatible input
 ST = Schmitt Trigger input with CMOS levels
 I = Input
 P = Power
 CMOS = CMOS compatible input or output
 Analog = Analog input
 O = Output
 OD = Open-Drain (no P diode to VDD)

- Note 1:** Alternate assignment for CCP2 when CCP2MX is not selected (all operating modes except Microcontroller).
- 2:** Default assignment when CCP2MX is set.
- 3:** External memory interface functions are only available on PIC18F8X20 devices.
- 4:** CCP2 is multiplexed with this pin by default when configured in Microcontroller mode. Otherwise, it is multiplexed with either RB3 or RC1.
- 5:** PORTH and PORTJ are only available on PIC18F8X20 (80-pin) devices.
- 6:** AVDD must be connected to a positive supply and AVSS must be connected to a ground reference for proper operation of the part in user or ICSP modes. See parameter D001A for details.

PIC18F6520/8520/6620/8620/6720/8720

TABLE 1-2: PIC18FXX20 PINOUT I/O DESCRIPTIONS (CONTINUED)

Pin Name	Pin Number		Pin Type	Buffer Type	Description
	PIC18F6X20	PIC18F8X20			
RG0/CCP3 RG0 CCP3	3	5	I/O I/O	ST ST	PORTG is a bidirectional I/O port. Digital I/O. Capture3 input/Compare3 output/ PWM3 output.
RG1/TX2/CK2 RG1 TX2 CK2	4	6	I/O O I/O	ST — ST	Digital I/O. USART 2 asynchronous transmit. USART 2 synchronous clock (see RX2/DT2).
RG2/RX2/DT2 RG2 RX2 DT2	5	7	I/O I I/O	ST ST ST	Digital I/O. USART 2 asynchronous receive. USART 2 synchronous data (see TX2/CK2).
RG3/CCP4 RG3 CCP4	6	8	I/O I/O	ST ST	Digital I/O. Capture4 input/Compare4 output/ PWM4 output.
RG4/CCP5 RG4 CCP5	8	10	I/O I/O	ST ST	Digital I/O. Capture5 input/Compare5 output/ PWM5 output.

Legend: TTL = TTL compatible input CMOS = CMOS compatible input or output
 ST = Schmitt Trigger input with CMOS levels Analog = Analog input
 I = Input O = Output
 P = Power OD = Open-Drain (no P diode to VDD)

- Note 1:** Alternate assignment for CCP2 when CCP2MX is not selected (all operating modes except Microcontroller).
- 2:** Default assignment when CCP2MX is set.
- 3:** External memory interface functions are only available on PIC18F8X20 devices.
- 4:** CCP2 is multiplexed with this pin by default when configured in Microcontroller mode. Otherwise, it is multiplexed with either RB3 or RC1.
- 5:** PORTH and PORTJ are only available on PIC18F8X20 (80-pin) devices.
- 6:** AVDD must be connected to a positive supply and AVSS must be connected to a ground reference for proper operation of the part in user or ICSP modes. See parameter D001A for details.

PIC18F6520/8520/6620/8620/6720/8720

TABLE 1-2: PIC18FXX20 PINOUT I/O DESCRIPTIONS (CONTINUED)

Pin Name	Pin Number		Pin Type	Buffer Type	Description
	PIC18F6X20	PIC18F8X20			
RH0/A16 RH0 A16	—	79	I/O O	ST TTL	PORTH is a bidirectional I/O port ⁽⁵⁾ . Digital I/O. External memory address 16.
RH1/A17 RH1 A17	—	80	I/O O	ST TTL	Digital I/O. External memory address 17.
RH2/A18 RH2 A18	—	1	I/O O	ST TTL	Digital I/O. External memory address 18.
RH3/A19 RH3 A19	—	2	I/O O	ST TTL	Digital I/O. External memory address 19.
RH4/AN12 RH4 AN12	—	22	I/O I	ST Analog	Digital I/O. Analog input 12.
RH5/AN13 RH5 AN13	—	21	I/O I	ST Analog	Digital I/O. Analog input 13.
RH6/AN14 RH6 AN14	—	20	I/O I	ST Analog	Digital I/O. Analog input 14.
RH7/AN15 RH7 AN15	—	19	I/O I	ST Analog	Digital I/O. Analog input 15.

Legend: TTL = TTL compatible input CMOS = CMOS compatible input or output
 ST = Schmitt Trigger input with CMOS levels Analog = Analog input
 I = Input O = Output
 P = Power OD = Open-Drain (no P diode to VDD)

- Note 1:** Alternate assignment for CCP2 when CCP2MX is not selected (all operating modes except Microcontroller).
- 2:** Default assignment when CCP2MX is set.
- 3:** External memory interface functions are only available on PIC18F8X20 devices.
- 4:** CCP2 is multiplexed with this pin by default when configured in Microcontroller mode. Otherwise, it is multiplexed with either RB3 or RC1.
- 5:** PORTH and PORTJ are only available on PIC18F8X20 (80-pin) devices.
- 6:** AVDD must be connected to a positive supply and AVSS must be connected to a ground reference for proper operation of the part in user or ICSP modes. See parameter D001A for details.

PIC18F6520/8520/6620/8620/6720/8720

TABLE 1-2: PIC18FXX20 PINOUT I/O DESCRIPTIONS (CONTINUED)

Pin Name	Pin Number		Pin Type	Buffer Type	Description
	PIC18F6X20	PIC18F8X20			
RJ0/ALE RJ0 ALE	—	62	I/O O	ST TTL	PORTJ is a bidirectional I/O port ⁽⁵⁾ . Digital I/O. External memory address latch enable.
RJ1/ $\overline{\text{OE}}$ RJ1 $\overline{\text{OE}}$	—	61	I/O O	ST TTL	Digital I/O. External memory output enable.
RJ2/ $\overline{\text{WRL}}$ RJ2 $\overline{\text{WRL}}$	—	60	I/O O	ST TTL	Digital I/O. External memory write low control.
RJ3/ $\overline{\text{WRH}}$ RJ3 $\overline{\text{WRH}}$	—	59	I/O O	ST TTL	Digital I/O. External memory write high control.
RJ4/BA0 RJ4 BA0	—	39	I/O O	ST TTL	Digital I/O. External memory Byte Address 0 control.
RJ5/ $\overline{\text{CE}}$ RJ5 $\overline{\text{CE}}$	—	40	I/O O	ST TTL	Digital I/O. External memory chip enable control.
RJ6/ $\overline{\text{LB}}$ RJ6 $\overline{\text{LB}}$	—	41	I/O O	ST TTL	Digital I/O. External memory low byte select.
RJ7/ $\overline{\text{UB}}$ RJ7 $\overline{\text{UB}}$	—	42	I/O O	ST TTL	Digital I/O. External memory high byte select.
VSS	9, 25, 41, 56	11, 31, 51, 70	P	—	Ground reference for logic and I/O pins.
VDD	10, 26, 38, 57	12, 32, 48, 71	P	—	Positive supply for logic and I/O pins.
AVSS ⁽⁶⁾	20	26	P	—	Ground reference for analog modules.
AVDD ⁽⁶⁾	19	25	P	—	Positive supply for analog modules.

Legend: TTL = TTL compatible input CMOS = CMOS compatible input or output
 ST = Schmitt Trigger input with CMOS levels Analog = Analog input
 I = Input O = Output
 P = Power OD = Open-Drain (no P diode to VDD)

- Note 1:** Alternate assignment for CCP2 when CCP2MX is not selected (all operating modes except Microcontroller).
- 2:** Default assignment when CCP2MX is set.
- 3:** External memory interface functions are only available on PIC18F8X20 devices.
- 4:** CCP2 is multiplexed with this pin by default when configured in Microcontroller mode. Otherwise, it is multiplexed with either RB3 or RC1.
- 5:** PORTH and PORTJ are only available on PIC18F8X20 (80-pin) devices.
- 6:** AVDD must be connected to a positive supply and AVSS must be connected to a ground reference for proper operation of the part in user or ICSP modes. See parameter D001A for details.

PIC18F6520/8520/6620/8620/6720/8720

2.0 OSCILLATOR CONFIGURATIONS

2.1 Oscillator Types

The PIC18FXX20 devices can be operated in eight different oscillator modes. The user can program three configuration bits (FOSC2, FOSC1 and FOSC0) to select one of these eight modes:

1. LP Low-Power Crystal
2. XT Crystal/Resonator
3. HS High-Speed Crystal/Resonator
4. HS+PLL High-Speed Crystal/Resonator with PLL enabled
5. RC External Resistor/Capacitor
6. RCIO External Resistor/Capacitor with I/O pin enabled
7. EC External Clock
8. ECIO External Clock with I/O pin enabled

2.2 Crystal Oscillator/Ceramic Resonators

In XT, LP, HS or HS+PLL Oscillator modes, a crystal or ceramic resonator is connected to the OSC1 and OSC2 pins to establish oscillation. Figure 2-1 shows the pin connections.

The PIC18FXX20 oscillator design requires the use of a parallel cut crystal.

Note: Use of a series cut crystal may give a frequency out of the crystal manufacturer's specifications.

FIGURE 2-1: CRYSTAL/CERAMIC RESONATOR OPERATION (HS, XT OR LP CONFIGURATION)

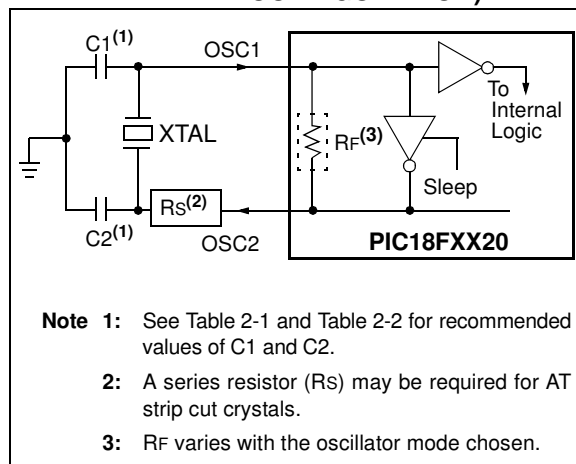

TABLE 2-1: CAPACITOR SELECTION FOR CERAMIC RESONATORS

Ranges Tested:			
Mode	Freq	C1	C2
XT	455 kHz	68-100 pF	68-100 pF
	2.0 MHz	15-68 pF	15-68 pF
	4.0 MHz	15-68 pF	15-68 pF
HS	8.0 MHz	10-68 pF	10-68 pF
	16.0 MHz	10-22 pF	10-22 pF
These values are for design guidance only. See notes following this table.			
Resonators Used:			
2.0 MHz	Murata Erie CSA2.00MG	± 0.5%	
4.0 MHz	Murata Erie CSA4.00MG	± 0.5%	
8.0 MHz	Murata Erie CSA8.00MT	± 0.5%	
16.0 MHz	Murata Erie CSA16.00MX	± 0.5%	
All resonators used did not have built-in capacitors.			

Note 1: Higher capacitance increases the stability of the oscillator, but also increases the start-up time.

2: When operating below 3V VDD, or when using certain ceramic resonators at any voltage, it may be necessary to use high gain HS mode, try a lower frequency resonator, or switch to a crystal oscillator.

3: Since each resonator/crystal has its own characteristics, the user should consult the resonator/crystal manufacturer for appropriate values of external components, or verify oscillator performance.

PIC18F6520/8520/6620/8620/6720/8720

TABLE 2-2: CAPACITOR SELECTION FOR CRYSTAL OSCILLATOR

Ranges Tested:			
Mode	Freq	C1	C2
LP	32 kHz	15-22 pF	15-22 pF
	200 kHz		
XT	1 MHz	15-22 pF	15-22 pF
	4 MHz		
HS	4 MHz	15-22 pF	15-22 pF
	8 MHz		
	20 MHz		

Capacitor values are for design guidance only.

These capacitors were tested with the above crystal frequencies for basic start-up and operation. **These values are not optimized.**

Different capacitor values may be required to produce acceptable oscillator operation. The user should test the performance of the oscillator over the expected VDD and temperature range for the application.

See the notes following this table for additional information.

- Note 1:** Higher capacitance increases the stability of the oscillator, but also increases the start-up time.
- When operating below 3V VDD, or when using certain ceramic resonators at any voltage, it may be necessary to use the HS mode or switch to a crystal oscillator.
 - Since each resonator/crystal has its own characteristics, the user should consult the resonator/crystal manufacturer for appropriate values of external components, or verify oscillator performance.
 - RS may be required to avoid overdriving crystals with low drive level specification.
 - Always verify oscillator performance over the VDD and temperature range that is expected for the application.

An external clock source may also be connected to the OSC1 pin in the HS, XT and LP modes, as shown in Figure 2-2.

FIGURE 2-2: EXTERNAL CLOCK INPUT OPERATION (HS, XT OR LPOSCCONFIGURATION)

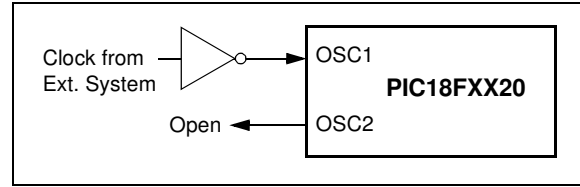

2.3 RC Oscillator

For timing insensitive applications, the “RC” and “RCIO” device options offer additional cost savings. The RC oscillator frequency is a function of the supply voltage, the resistor (R_{EXT}) and capacitor (C_{EXT}) values and the operating temperature. In addition to this, the oscillator frequency will vary from unit to unit, due to normal process parameter variation. Furthermore, the difference in lead frame capacitance between package types will also affect the oscillation frequency, especially for low C_{EXT} values. The user also needs to take into account variation due to tolerance of external R and C components used. Figure 2-3 shows how the R/C combination is connected.

In the RC Oscillator mode, the oscillator frequency divided by 4 is available on the OSC2 pin. This signal may be used for test purposes or to synchronize other logic.

FIGURE 2-3: RC OSCILLATOR MODE

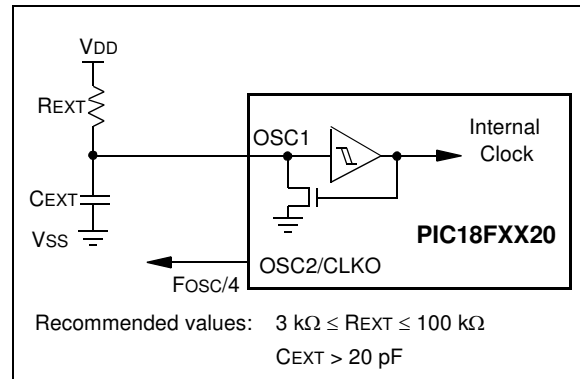

The RCIO Oscillator mode functions like the RC mode, except that the OSC2 pin becomes an additional general purpose I/O pin. The I/O pin becomes bit 6 of PORTA (RA6).

PIC18F6520/8520/6620/8620/6720/8720

2.4 External Clock Input

The EC and ECIO Oscillator modes require an external clock source to be connected to the OSC1 pin. The feedback device between OSC1 and OSC2 is turned off in these modes to save current. There is a maximum 1.5 μ s start-up required after a Power-on Reset, or wake-up from Sleep mode.

In the EC Oscillator mode, the oscillator frequency divided by 4 is available on the OSC2 pin. This signal may be used for test purposes or to synchronize other logic. Figure 2-4 shows the pin connections for the EC Oscillator mode.

FIGURE 2-4: EXTERNAL CLOCK INPUT OPERATION (EC CONFIGURATION)

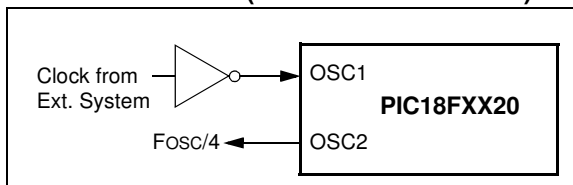

The ECIO Oscillator mode functions like the EC mode, except that the OSC2 pin becomes an additional general purpose I/O pin. The I/O pin becomes bit 6 of PORTA (RA6). Figure 2-5 shows the pin connections for the ECIO Oscillator mode.

FIGURE 2-5: EXTERNAL CLOCK INPUT OPERATION (ECIO CONFIGURATION)

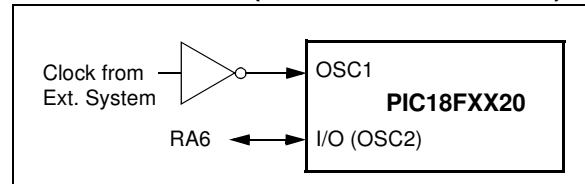

2.5 HS/PLL

A Phase Locked Loop circuit (PLL) is provided as a programmable option for users that want to multiply the frequency of the incoming crystal oscillator signal by 4. For an input clock frequency of 10 MHz, the internal clock frequency will be multiplied to 40 MHz. This is useful for customers who are concerned with EMI due to high-frequency crystals.

The PLL is one of the modes of the FOSC<2:0> configuration bits. The oscillator mode is specified during device programming.

The PLL can only be enabled when the oscillator configuration bits are programmed for HS mode. If they are programmed for any other mode, the PLL is not enabled and the system clock will come directly from OSC1. Also, PLL operation cannot be changed “on-the-fly”. To enable or disable it, the controller must either cycle through a Power-on Reset, or switch the clock source from the main oscillator to the Timer1 oscillator and back again. See **Section 2.6 “Oscillator Switching Feature”** for details on oscillator switching.

A PLL lock timer is used to ensure that the PLL has locked before device execution starts. The PLL lock timer has a time-out that is called TPLL.

FIGURE 2-6: PLL BLOCK DIAGRAM

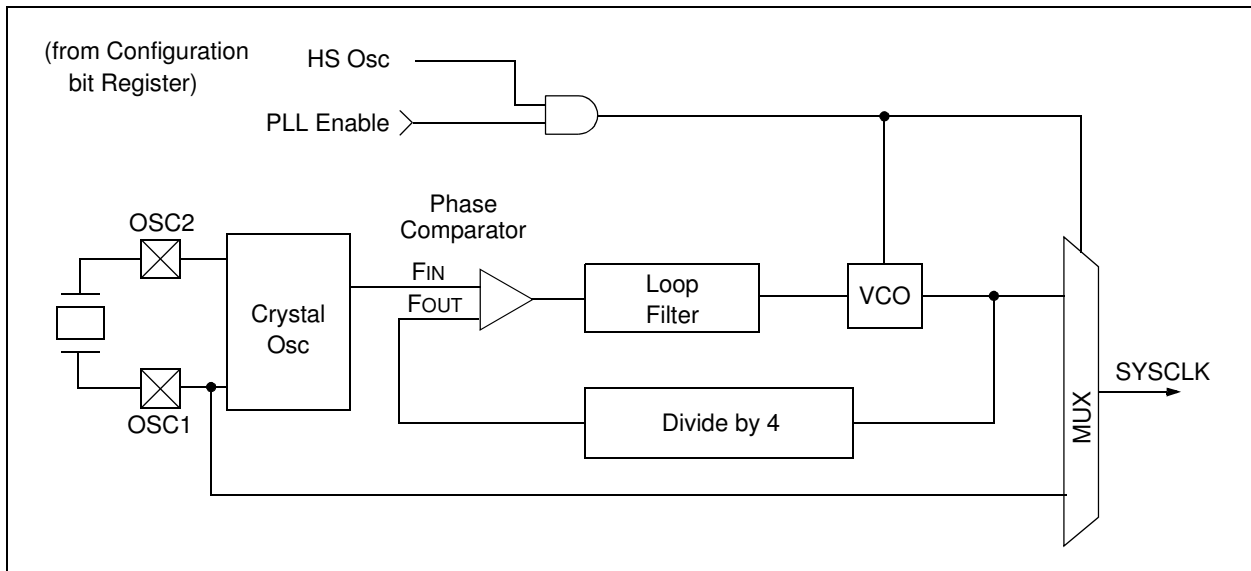

PIC18F6520/8520/6620/8620/6720/8720

2.6 Oscillator Switching Feature

The PIC18FXX20 devices include a feature that allows the system clock source to be switched from the main oscillator to an alternate low-frequency clock source. For the PIC18FXX20 devices, this alternate clock source is the Timer1 oscillator. If a low-frequency crystal (32 kHz, for example) has been attached to the Timer1 oscillator pins and the Timer1 oscillator has been enabled, the device can switch to a low-power

execution mode. Figure 2-7 shows a block diagram of the system clock sources. The clock switching feature is enabled by programming the Oscillator Switching Enable (OSCSEN) bit in Configuration Register 1H to a '0'. Clock switching is disabled in an erased device. See **Section 12.0 "Timer1 Module"** for further details of the Timer1 oscillator. See **Section 23.0 "Special Features of the CPU"** for Configuration register details.

FIGURE 2-7: DEVICE CLOCK SOURCES

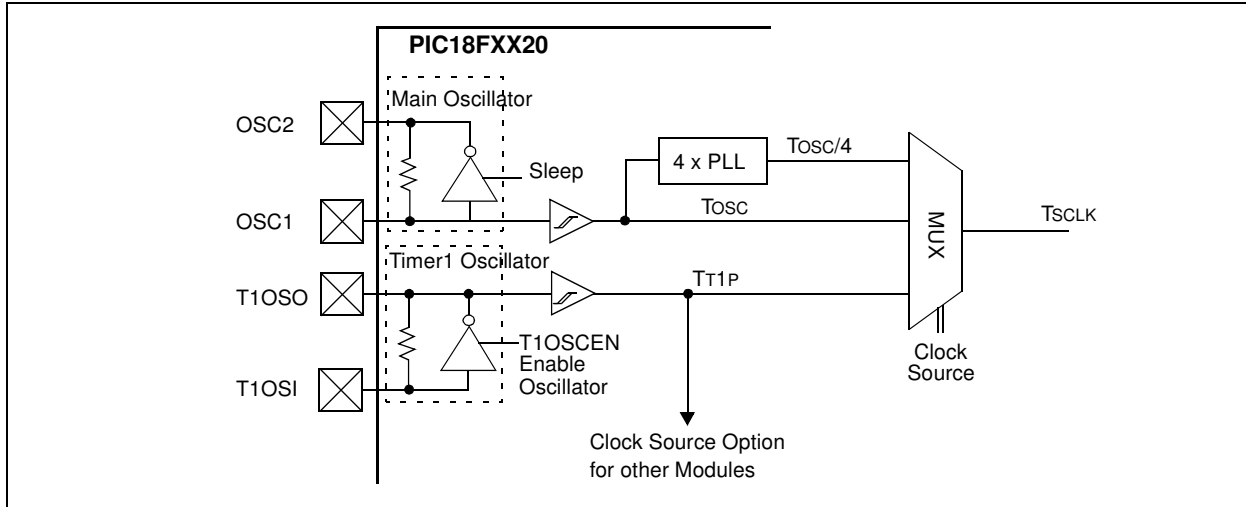

PIC18F6520/8520/6620/8620/6720/8720

2.6.1 SYSTEM CLOCK SWITCH BIT

The system clock source switching is performed under software control. The system clock switch bit, SCS (OSCCON<0>), controls the clock switching. When the SCS bit is '0', the system clock source comes from the main oscillator that is selected by the FOSC configuration bits in Configuration Register 1H. When the SCS bit is set, the system clock source will come from the Timer1 oscillator. The SCS bit is cleared on all forms of Reset.

Note: The Timer1 oscillator must be enabled and operating to switch the system clock source. The Timer1 oscillator is enabled by setting the T1OSCEN bit in the Timer1 Control register (T1CON). If the Timer1 oscillator is not enabled, then any write to the SCS bit will be ignored (SCS bit forced cleared) and the main oscillator will continue to be the system clock source.

REGISTER 2-1: OSCCON REGISTER

U-0	U-0	U-0	U-0	U-0	U-0	U-0	R/W-1
—	—	—	—	—	—	—	SCS
bit 7							bit 0

bit 7-1 **Unimplemented:** Read as '0'

bit 0 **SCS:** System Clock Switch bit

When $\overline{\text{OSCSSEN}}$ Configuration bit = 0 and T1OSCEN bit is set:

1 = Switch to Timer1 oscillator/clock pin

0 = Use primary oscillator/clock input pin

When $\overline{\text{OSCSSEN}}$ and T1OSCEN are in other states:

Bit is forced clear.

Legend:

R = Readable bit

W = Writable bit

U = Unimplemented bit, read as '0'

- n = Value at POR

'1' = Bit is set

'0' = Bit is cleared

x = Bit is unknown

PIC18F6520/8520/6620/8620/6720/8720

2.6.2 OSCILLATOR TRANSITIONS

PIC18FXX20 devices contain circuitry to prevent “glitches” when switching between oscillator sources. Essentially, the circuitry waits for eight rising edges of the clock source that the processor is switching to. This ensures that the new clock source is stable and that its pulse width will not be less than the shortest pulse width of the two clock sources.

A timing diagram indicating the transition from the main oscillator to the Timer1 oscillator is shown in Figure 2-8. The Timer1 oscillator is assumed to be running all the time. After the SCS bit is set, the processor is frozen at the next occurring Q1 cycle. After eight synchronization cycles are counted from the Timer1 oscillator, operation resumes. No additional delays are required after the synchronization cycles.

FIGURE 2-8: TIMING DIAGRAM FOR TRANSITION FROM OSC1 TO TIMER1 OSCILLATOR

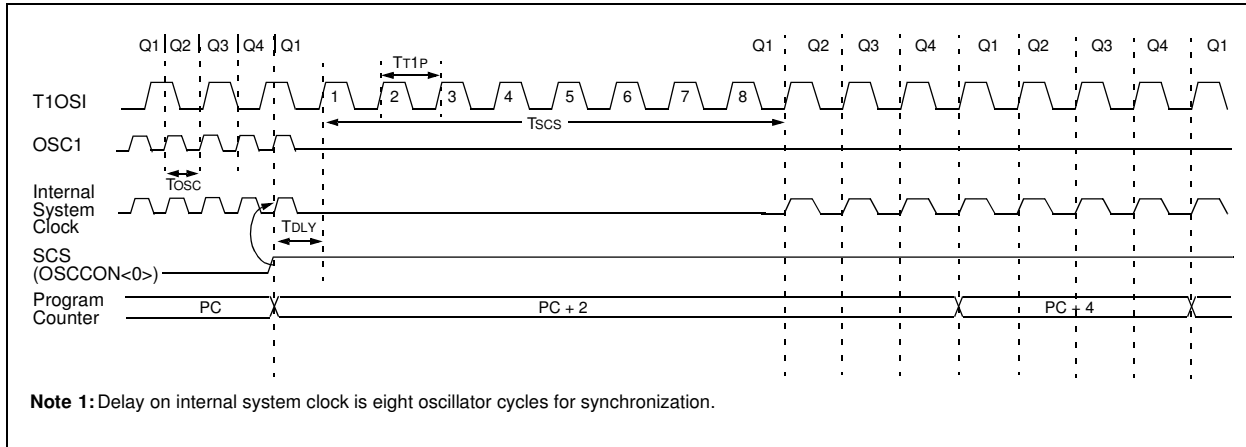

The sequence of events that takes place when switching from the Timer1 oscillator to the main oscillator will depend on the mode of the main oscillator. In addition to eight clock cycles of the main oscillator, additional delays may take place.

If the main oscillator is configured for an external crystal (HS, XT, LP), then the transition will take place after an oscillator start-up time (TOST) has occurred. A timing diagram, indicating the transition from the Timer1 oscillator to the main oscillator for HS, XT and LP modes, is shown in Figure 2-9.

FIGURE 2-9: TIMING FOR TRANSITION BETWEEN TIMER1 AND OSC1 (HS, XT, LP)

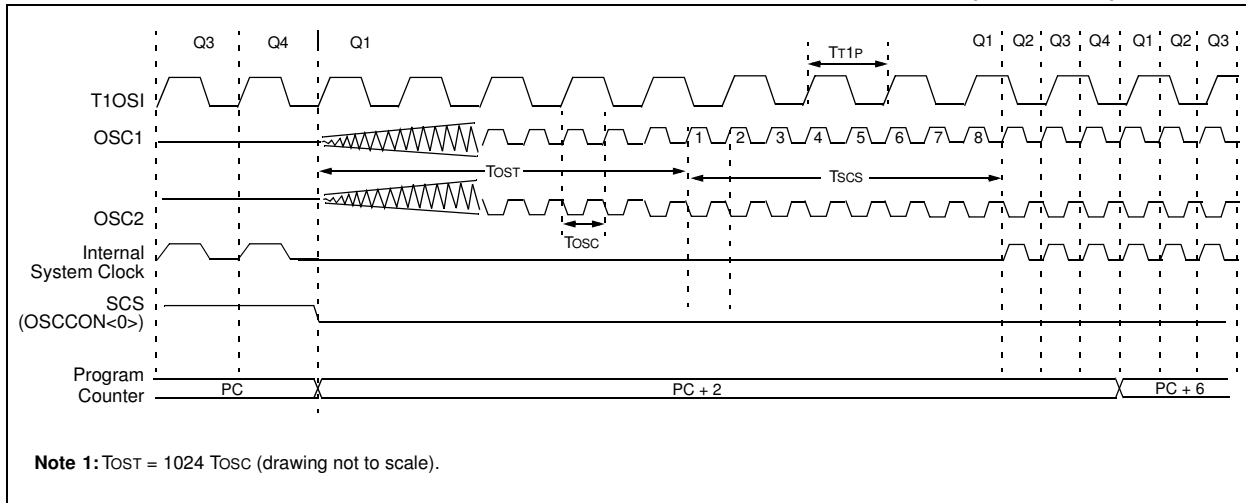

PIC18F6520/8520/6620/8620/6720/8720

If the main oscillator is configured for HS-PLL mode, an oscillator start-up time (T_{OST}), plus an additional PLL time-out (T_{PLL}), will occur. The PLL time-out is typically 2 ms and allows the PLL to lock to the main oscillator

frequency. A timing diagram, indicating the transition from the Timer1 oscillator to the main oscillator for HS-PLL mode, is shown in Figure 2-10.

FIGURE 2-10: TIMING FOR TRANSITION BETWEEN TIMER1 AND OSC1 (HS WITH PLL)

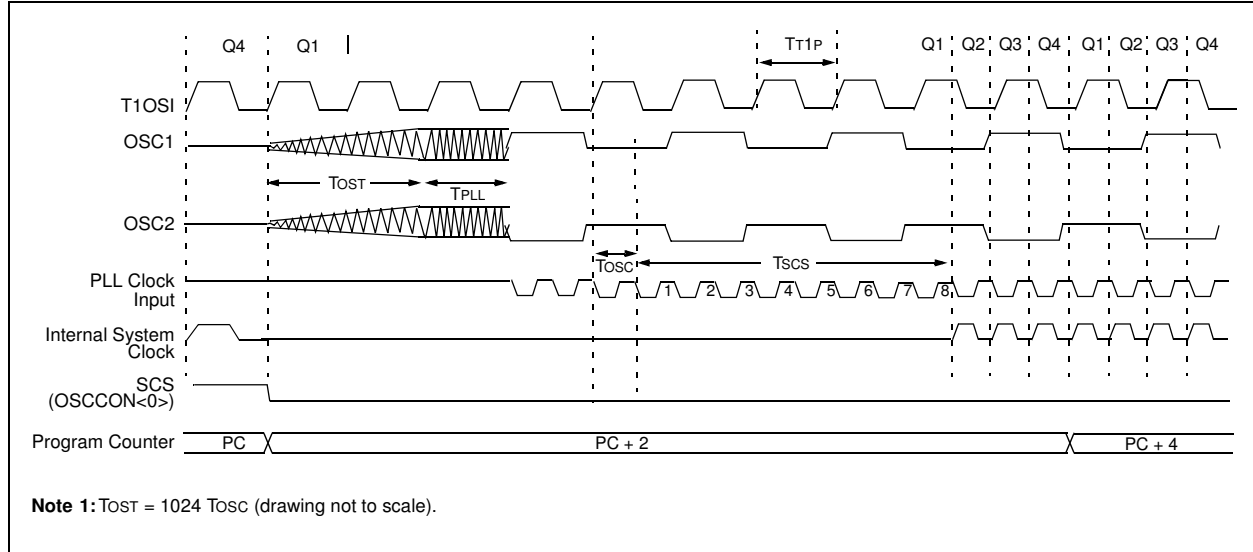

If the main oscillator is configured in the RC, RCIO, EC or ECIO modes, there is no oscillator start-up time-out. Operation will resume after eight cycles of the main oscillator have been counted. A timing diagram,

indicating the transition from the Timer1 oscillator to the main oscillator for RC, RCIO, EC and ECIO modes, is shown in Figure 2-11.

FIGURE 2-11: TIMING FOR TRANSITION BETWEEN TIMER1 AND OSC1 (RC, EC)

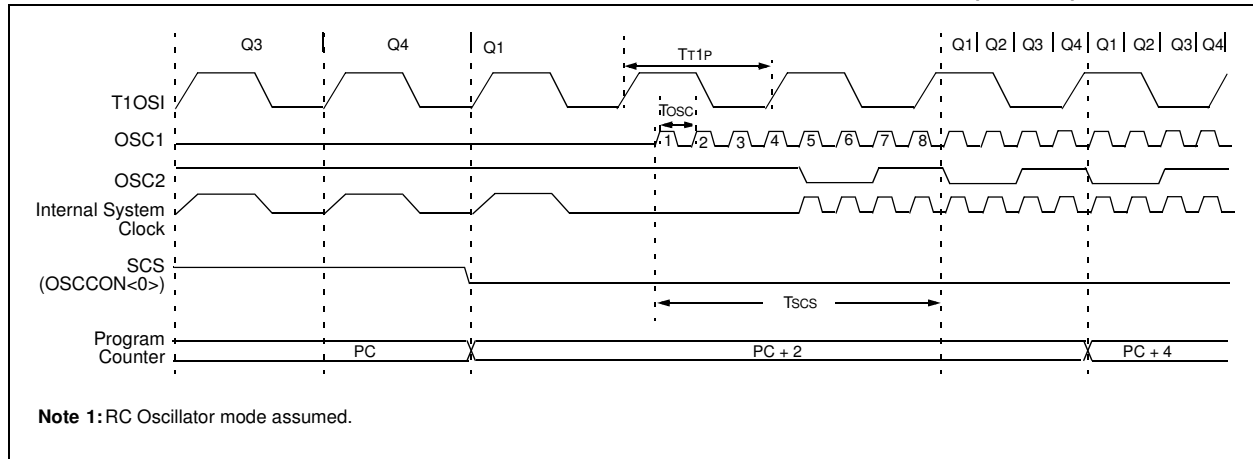

PIC18F6520/8520/6620/8620/6720/8720

2.7 Effects of Sleep Mode on the On-Chip Oscillator

When the device executes a `SLEEP` instruction, the on-chip clocks and oscillator are turned off and the device is held at the beginning of an instruction cycle (Q1 state). With the oscillator off, the OSC1 and OSC2 signals will stop oscillating. Since all the transistor switching currents have been removed, Sleep mode achieves the lowest current consumption of the device (only leakage currents). Enabling any on-chip feature that will operate during Sleep will increase the current consumed during Sleep. The user can wake from Sleep through external Reset, Watchdog Timer Reset or through an interrupt.

2.8 Power-up Delays

Power up delays are controlled by two timers so that no external Reset circuitry is required for most applications. The delays ensure that the device is kept in Reset until the device power supply and clock are stable. For additional information on Reset operation, see **Section 3.0 "Reset"**.

The first timer is the Power-up Timer (PWRT), which optionally provides a fixed delay of 72 ms (nominal) on power-up only (POR and BOR). The second timer is the Oscillator Start-up Timer (OST), intended to keep the chip in Reset until the crystal oscillator is stable.

With the PLL enabled (HS/PLL Oscillator mode), the time-out sequence following a Power-on Reset is different from other oscillator modes. The time-out sequence is as follows: First, the PWRT time-out is invoked after a POR time delay has expired. Then, the Oscillator Start-up Timer (OST) is invoked. However, this is still not a sufficient amount of time to allow the PLL to lock at high frequencies. The PWRT timer is used to provide an additional fixed 2 ms (nominal) time-out to allow the PLL ample time to lock to the incoming clock frequency.

TABLE 2-3: OSC1 AND OSC2 PIN STATES IN SLEEP MODE

OSC Mode	OSC1 Pin	OSC2 Pin
RC	Floating, external resistor should pull high	At logic low
RCIO	Floating, external resistor should pull high	Configured as PORTA, bit 6
ECIO	Floating	Configured as PORTA, bit 6
EC	Floating	At logic low
LP, XT and HS	Feedback inverter disabled at quiescent voltage level	Feedback inverter disabled at quiescent voltage level

Note: See Table 3-1 in **Section 3.0 "Reset"** for time-outs due to Sleep and MCLR Reset.

PIC18F6520/8520/6620/8620/6720/8720

3.0 RESET

The PIC18FXX20 devices differentiate between various kinds of Reset:

- Power-on Reset (POR)
- $\overline{\text{MCLR}}$ Reset during normal operation
- $\overline{\text{MCLR}}$ Reset during Sleep
- Watchdog Timer (WDT) Reset (during normal operation)
- Programmable Brown-out Reset (PBOR)
- RESET Instruction
- Stack Full Reset
- Stack Underflow Reset

Most registers are unaffected by a Reset. Their status is unknown on POR and unchanged by all other Resets. The other registers are forced to a "Reset state" on Power-on Reset, $\overline{\text{MCLR}}$, WDT Reset, Brown-out Reset, $\overline{\text{MCLR}}$ Reset during Sleep and by the RESET instruction.

Most registers are not affected by a WDT wake-up, since this is viewed as the resumption of normal operation. Status bits from the RCON register, $\overline{\text{RI}}$, $\overline{\text{TO}}$, $\overline{\text{PD}}$, $\overline{\text{POR}}$ and $\overline{\text{BOR}}$, are set or cleared differently in different Reset situations, as indicated in Table 3-2. These bits are used in software to determine the nature of the Reset. See Table 3-3 for a full description of the Reset states of all registers.

A simplified block diagram of the On-Chip Reset Circuit is shown in Figure 3-1.

The Enhanced MCU devices have a $\overline{\text{MCLR}}$ noise filter in the $\overline{\text{MCLR}}$ Reset path. The filter will detect and ignore small pulses. The $\overline{\text{MCLR}}$ pin is not driven low by any internal Resets, including the WDT.

FIGURE 3-1: SIMPLIFIED BLOCK DIAGRAM OF ON-CHIP RESET CIRCUIT

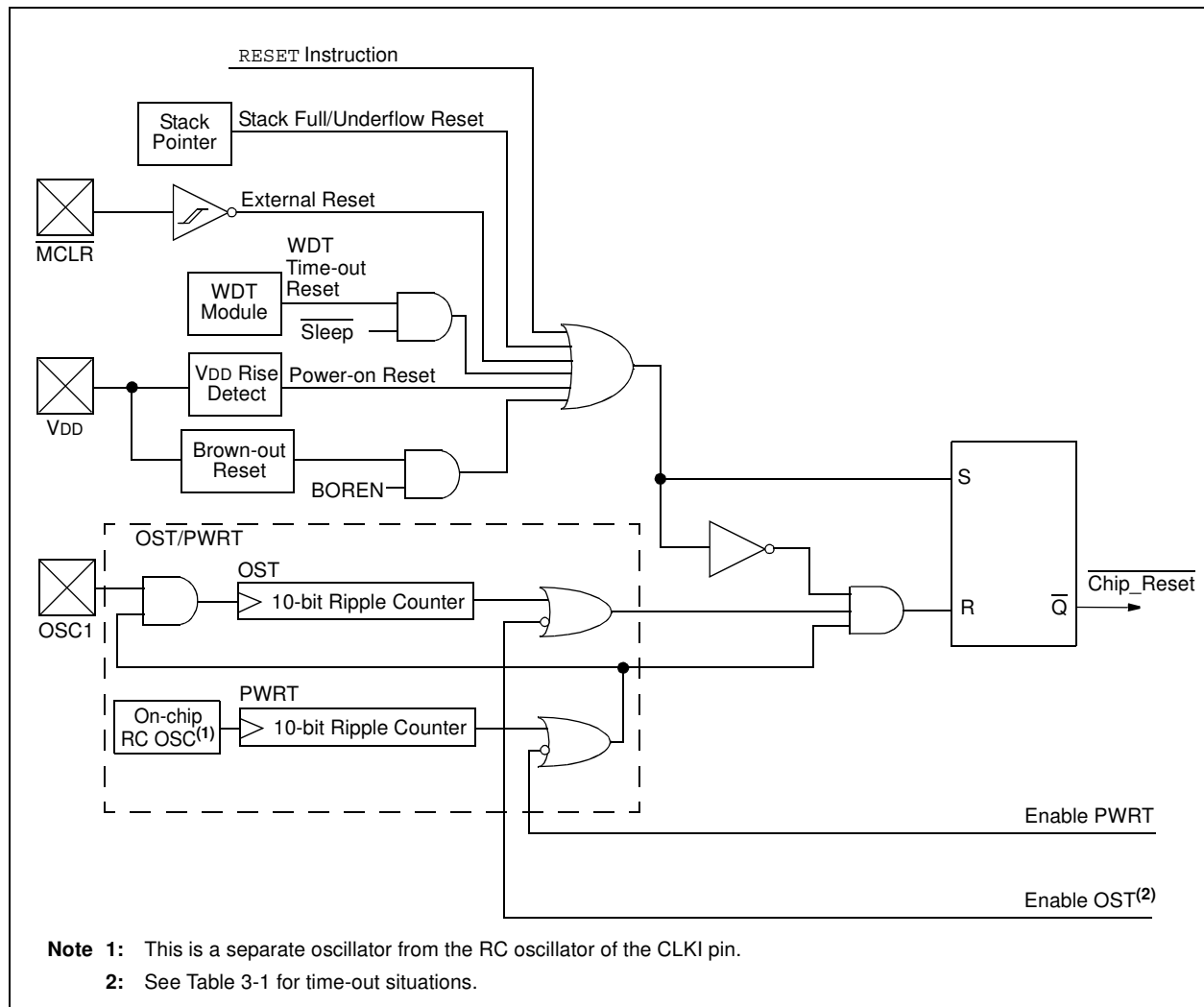

PIC18F6520/8520/6620/8620/6720/8720

3.1 Power-on Reset (POR)

A Power-on Reset pulse is generated on-chip when VDD rise is detected. To take advantage of the POR circuitry, tie the $\overline{\text{MCLR}}$ pin through a 1 k Ω to 10 k Ω resistor to VDD. This will eliminate external RC components usually needed to create a Power-on Reset delay. A minimum rise rate for VDD is specified (parameter D004). For a slow rise time, see Figure 3-2.

When the device starts normal operation (i.e., exits the Reset condition), device operating parameters (voltage, frequency, temperature, etc.) must be met to ensure operation. If these conditions are not met, the device must be held in Reset until the operating conditions are met.

FIGURE 3-2: EXTERNAL POWER-ON RESET CIRCUIT (FOR SLOW VDD POWER-UP)

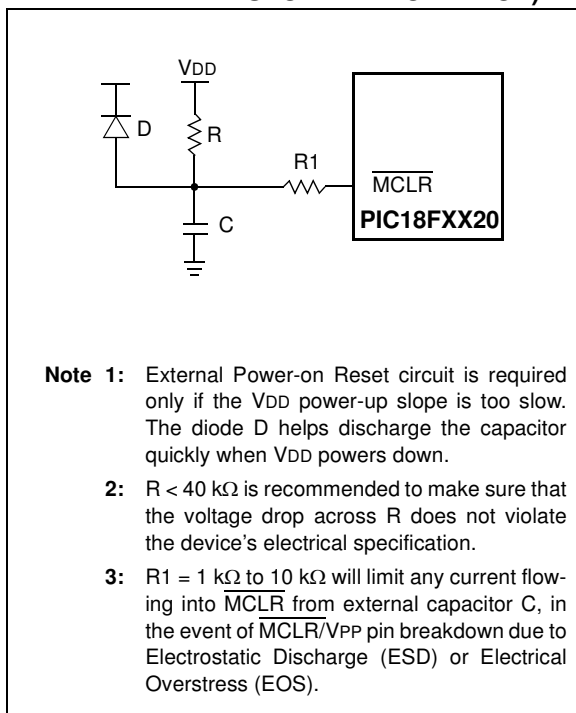

3.2 Power-up Timer (PWRT)

The Power-up Timer provides a fixed nominal time-out (parameter #33) only on power-up from the POR. The Power-up Timer operates on an internal RC oscillator. The chip is kept in Reset as long as the PWRT is active. The PWRT's time delay allows VDD to rise to an acceptable level. A configuration bit is provided to enable/disable the PWRT.

The power-up time delay will vary from chip-to-chip due to VDD, temperature and process variation. See DC parameter #33 for details.

3.3 Oscillator Start-up Timer (OST)

The Oscillator Start-up Timer (OST) provides 1024 oscillator cycles (from OSC1 input) delay after the PWRT delay is over (parameter #32). This ensures that the crystal oscillator or resonator has started and stabilized.

The OST time-out is invoked only for XT, LP and HS modes and only on Power-on Reset, or wake-up from Sleep.

3.4 PLL Lock Time-out

With the PLL enabled, the time-out sequence following a Power-on Reset is different from other oscillator modes. A portion of the Power-up Timer is used to provide a fixed time-out that is sufficient for the PLL to lock to the main oscillator frequency. This PLL lock time-out (TPLL) is typically 2 ms and follows the oscillator start-up time-out.

3.5 Brown-out Reset (BOR)

A configuration bit, BOREN, can disable (if clear/programmed), or enable (if set) the Brown-out Reset circuitry. If VDD falls below parameter D005 for greater than parameter #35, the brown-out situation will reset the chip. A Reset may not occur if VDD falls below parameter D005 for less than parameter #35. The chip will remain in Brown-out Reset until VDD rises above BVDD. If the Power-up Timer is enabled, it will be invoked after VDD rises above BVDD; it then will keep the chip in Reset for an additional time delay (parameter #33). If VDD drops below BVDD while the Power-up Timer is running, the chip will go back into a Brown-out Reset and the Power-up Timer will be initialized. Once VDD rises above BVDD, the Power-up Timer will execute the additional time delay.

3.6 Time-out Sequence

On power-up, the time-out sequence is as follows: First, PWRT time-out is invoked after the POR time delay has expired. Then, OST is activated. The total time-out will vary based on oscillator configuration and the status of the PWRT. For example, in RC mode with the PWRT disabled, there will be no time-out at all. Figures 3-3 through 3-7 depict time-out sequences on power-up.

Since the time-outs occur from the POR pulse, the time-outs will expire if $\overline{\text{MCLR}}$ is kept low long enough. Bringing $\overline{\text{MCLR}}$ high will begin execution immediately (Figure 3-5). This is useful for testing purposes, or to synchronize more than one PIC18FXX20 device operating in parallel.

Table 3-2 shows the Reset conditions for some Special Function Registers, while Table 3-3 shows the Reset conditions for all of the registers.

PIC18F6520/8520/6620/8620/6720/8720

TABLE 3-1: TIME-OUT IN VARIOUS SITUATIONS

Oscillator Configuration	Power-up ⁽²⁾		Brown-out	Wake-up from Sleep or Oscillator Switch
	$\overline{\text{PWRTE}} = 0$	$\overline{\text{PWRTE}} = 1$		
HS with PLL enabled ⁽¹⁾	72 ms + 1024 TOSC + 2ms	1024 TOSC + 2 ms	72 ms ⁽²⁾ + 1024 TOSC + 2 ms	1024 TOSC + 2 ms
HS, XT, LP	72 ms + 1024 TOSC	1024 TOSC	72 ms ⁽²⁾ + 1024 TOSC	1024 TOSC
EC	72 ms	1.5 μs	72 ms ⁽²⁾	1.5 μs ⁽³⁾
External RC	72 ms	—	72 ms ⁽²⁾	—

Note 1: 2 ms is the nominal time required for the 4xPLL to lock.

Note 2: 72 ms is the nominal power-up timer delay, if implemented.

Note 3: 1.5 μs is the recovery time from Sleep. There is no recovery time from oscillator switch.

REGISTER 3-1: RCON REGISTER BITS AND POSITIONS

R/W-0	U-0	U-0	R/W-1	R/W-1	R/W-1	R/W-1	R/W-1	
IPEN	—	—	$\overline{\text{RI}}$	$\overline{\text{TO}}$	$\overline{\text{PD}}$	$\overline{\text{POR}}$	$\overline{\text{BOR}}$	
bit 7								bit 0

Note 1: Refer to Section 4.14 “RCON Register” for bit definitions.

TABLE 3-2: STATUS BITS, THEIR SIGNIFICANCE AND THE INITIALIZATION CONDITION FOR RCON REGISTER

Condition	Program Counter	RCON Register	$\overline{\text{RI}}$	$\overline{\text{TO}}$	$\overline{\text{PD}}$	$\overline{\text{POR}}$	$\overline{\text{BOR}}$	STKFUL	STKUNF
Power-on Reset	0000h	0--1 1100	1	1	1	0	0	u	u
MCLR Reset during normal operation	0000h	0--u uuuu	u	u	u	u	u	u	u
Software Reset during normal operation	0000h	0--0 uuuu	0	u	u	u	u	u	u
Stack Full Reset during normal operation	0000h	0--u uu11	u	u	u	u	u	u	1
Stack Underflow Reset during normal operation	0000h	0--u uu11	u	u	u	u	u	1	u
MCLR Reset during Sleep	0000h	0--u 10uu	u	1	0	u	u	u	u
WDT Reset	0000h	0--u 01uu	1	0	1	u	u	u	u
WDT Wake-up	PC + 2	u--u 00uu	u	0	0	u	u	u	u
Brown-out Reset	0000h	0--1 11u0	1	1	1	1	0	u	u
Interrupt wake-up from Sleep	PC + 2 ⁽¹⁾	u--u 00uu	u	1	0	u	u	u	u

Legend: u = unchanged, x = unknown, — = unimplemented bit, read as ‘0’

Note 1: When the wake-up is due to an interrupt and the GIEH or GIEL bits are set, the PC is loaded with the interrupt vector (0x000008h or 0x000018h).

PIC18F6520/8520/6620/8620/6720/8720

TABLE 3-3: INITIALIZATION CONDITIONS FOR ALL REGISTERS

Register	Applicable Devices		Power-on Reset, Brown-out Reset	MCLR Resets WDT Reset RESET Instruction Stack Resets	Wake-up via WDT or Interrupt
TOSU	PIC18F6X20	PIC18F8X20	---0 0000	---0 0000	---0 uuuu ⁽³⁾
TOSH	PIC18F6X20	PIC18F8X20	0000 0000	0000 0000	uuuu uuuu ⁽³⁾
TOSL	PIC18F6X20	PIC18F8X20	0000 0000	0000 0000	uuuu uuuu ⁽³⁾
STKPTR	PIC18F6X20	PIC18F8X20	00-0 0000	uu-0 0000	uu-u uuuu ⁽³⁾
PCLATU	PIC18F6X20	PIC18F8X20	---0 0000	---0 0000	---u uuuu
PCLATH	PIC18F6X20	PIC18F8X20	0000 0000	0000 0000	uuuu uuuu
PCL	PIC18F6X20	PIC18F8X20	0000 0000	0000 0000	PC + 2 ⁽²⁾
TBLPTRU	PIC18F6X20	PIC18F8X20	--00 0000	--00 0000	--uu uuuu
TBLPTRH	PIC18F6X20	PIC18F8X20	0000 0000	0000 0000	uuuu uuuu
TBLPTRL	PIC18F6X20	PIC18F8X20	0000 0000	0000 0000	uuuu uuuu
TABLAT	PIC18F6X20	PIC18F8X20	0000 0000	0000 0000	uuuu uuuu
PRODH	PIC18F6X20	PIC18F8X20	xxxx xxxx	uuuu uuuu	uuuu uuuu
PRODL	PIC18F6X20	PIC18F8X20	xxxx xxxx	uuuu uuuu	uuuu uuuu
INTCON	PIC18F6X20	PIC18F8X20	0000 000x	0000 000u	uuuu uuuu ⁽¹⁾
INTCON2	PIC18F6X20	PIC18F8X20	1111 1111	1111 1111	uuuu uuuu ⁽¹⁾
INTCON3	PIC18F6X20	PIC18F8X20	1100 0000	1100 0000	uuuu uuuu ⁽¹⁾
INDF0	PIC18F6X20	PIC18F8X20	N/A	N/A	N/A
POSTINC0	PIC18F6X20	PIC18F8X20	N/A	N/A	N/A
POSTDEC0	PIC18F6X20	PIC18F8X20	N/A	N/A	N/A
PREINC0	PIC18F6X20	PIC18F8X20	N/A	N/A	N/A
PLUSW0	PIC18F6X20	PIC18F8X20	N/A	N/A	N/A
FSR0H	PIC18F6X20	PIC18F8X20	---- xxxx	---- uuuu	---- uuuu
FSR0L	PIC18F6X20	PIC18F8X20	xxxx xxxx	uuuu uuuu	uuuu uuuu
WREG	PIC18F6X20	PIC18F8X20	xxxx xxxx	uuuu uuuu	uuuu uuuu
INDF1	PIC18F6X20	PIC18F8X20	N/A	N/A	N/A
POSTINC1	PIC18F6X20	PIC18F8X20	N/A	N/A	N/A
POSTDEC1	PIC18F6X20	PIC18F8X20	N/A	N/A	N/A
PREINC1	PIC18F6X20	PIC18F8X20	N/A	N/A	N/A
PLUSW1	PIC18F6X20	PIC18F8X20	N/A	N/A	N/A

Legend: u = unchanged, x = unknown, - = unimplemented bit, read as '0', q = value depends on condition.
Shaded cells indicate conditions do not apply for the designated device.

Note 1: One or more bits in the INTCONx or PIRx registers will be affected (to cause wake-up).

2: When the wake-up is due to an interrupt and the GIEL or GIEH bit is set, the PC is loaded with the interrupt vector (0008h or 0018h).

3: When the wake-up is due to an interrupt and the GIEL or GIEH bit is set, the TOSU, TOSH and TOSL are updated with the current value of the PC. The STKPTR is modified to point to the next location in the hardware stack.

4: See Table 3-2 for Reset value for specific condition.

5: Bit 6 of PORTA, LATA and TRISA are enabled in ECIO and RCIO Oscillator modes only. In all other oscillator modes, they are disabled and read '0'.

6: Bit 6 of PORTA, LATA and TRISA are not available on all devices. When unimplemented, they are read '0'.

PIC18F6520/8520/6620/8620/6720/8720

TABLE 3-3: INITIALIZATION CONDITIONS FOR ALL REGISTERS (CONTINUED)

Register	Applicable Devices		Power-on Reset, Brown-out Reset	MCLR Resets WDT Reset RESET Instruction Stack Resets	Wake-up via WDT or Interrupt
FSR1H	PIC18F6X20	PIC18F8X20	---- xxxx	---- uuuu	---- uuuu
FSR1L	PIC18F6X20	PIC18F8X20	xxxx xxxx	uuuu uuuu	uuuu uuuu
BSR	PIC18F6X20	PIC18F8X20	---- 0000	---- 0000	---- uuuu
INDF2	PIC18F6X20	PIC18F8X20	N/A	N/A	N/A
POSTINC2	PIC18F6X20	PIC18F8X20	N/A	N/A	N/A
POSTDEC2	PIC18F6X20	PIC18F8X20	N/A	N/A	N/A
PREINC2	PIC18F6X20	PIC18F8X20	N/A	N/A	N/A
PLUSW2	PIC18F6X20	PIC18F8X20	N/A	N/A	N/A
FSR2H	PIC18F6X20	PIC18F8X20	---- xxxx	---- uuuu	---- uuuu
FSR2L	PIC18F6X20	PIC18F8X20	xxxx xxxx	uuuu uuuu	uuuu uuuu
STATUS	PIC18F6X20	PIC18F8X20	---x xxxx	---u uuuu	---u uuuu
TMR0H	PIC18F6X20	PIC18F8X20	0000 0000	uuuu uuuu	uuuu uuuu
TMR0L	PIC18F6X20	PIC18F8X20	xxxx xxxx	uuuu uuuu	uuuu uuuu
T0CON	PIC18F6X20	PIC18F8X20	1111 1111	1111 1111	uuuu uuuu
OSCCON	PIC18F6X20	PIC18F8X20	---- ---0	---- ---0	---- ---u
LVDCON	PIC18F6X20	PIC18F8X20	--00 0101	--00 0101	--uu uuuu
WDTCON	PIC18F6X20	PIC18F8X20	---- ---0	---- ---0	---- ---u
RCON ⁽⁴⁾	PIC18F6X20	PIC18F8X20	0--q 11qq	0--q qquu	u--u qquu
TMR1H	PIC18F6X20	PIC18F8X20	xxxx xxxx	uuuu uuuu	uuuu uuuu
TMR1L	PIC18F6X20	PIC18F8X20	xxxx xxxx	uuuu uuuu	uuuu uuuu
T1CON	PIC18F6X20	PIC18F8X20	0-00 0000	u-uu uuuu	u-uu uuuu
TMR2	PIC18F6X20	PIC18F8X20	0000 0000	0000 0000	uuuu uuuu
PR2	PIC18F6X20	PIC18F8X20	1111 1111	1111 1111	1111 1111
T2CON	PIC18F6X20	PIC18F8X20	-000 0000	-000 0000	-uuu uuuu
SSPBUF	PIC18F6X20	PIC18F8X20	xxxx xxxx	uuuu uuuu	uuuu uuuu
SSPADD	PIC18F6X20	PIC18F8X20	0000 0000	0000 0000	uuuu uuuu
SSPSTAT	PIC18F6X20	PIC18F8X20	0000 0000	0000 0000	uuuu uuuu
SSPCON1	PIC18F6X20	PIC18F8X20	0000 0000	0000 0000	uuuu uuuu
SSPCON2	PIC18F6X20	PIC18F8X20	0000 0000	0000 0000	uuuu uuuu

Legend: u = unchanged, x = unknown, - = unimplemented bit, read as '0', q = value depends on condition. Shaded cells indicate conditions do not apply for the designated device.

- Note 1:** One or more bits in the INTCONx or PIRx registers will be affected (to cause wake-up).
- 2:** When the wake-up is due to an interrupt and the GIEL or GIEH bit is set, the PC is loaded with the interrupt vector (0008h or 0018h).
- 3:** When the wake-up is due to an interrupt and the GIEL or GIEH bit is set, the TOSU, TOSH and TOSL are updated with the current value of the PC. The STKPTR is modified to point to the next location in the hardware stack.
- 4:** See Table 3-2 for Reset value for specific condition.
- 5:** Bit 6 of PORTA, LATA and TRISA are enabled in ECIO and RCIO Oscillator modes only. In all other oscillator modes, they are disabled and read '0'.
- 6:** Bit 6 of PORTA, LATA and TRISA are not available on all devices. When unimplemented, they are read '0'.

PIC18F6520/8520/6620/8620/6720/8720

TABLE 3-3: INITIALIZATION CONDITIONS FOR ALL REGISTERS (CONTINUED)

Register	Applicable Devices		Power-on Reset, Brown-out Reset	MCLR Resets WDT Reset RESET Instruction Stack Resets	Wake-up via WDT or Interrupt
ADRESH	PIC18F6X20	PIC18F8X20	xxxx xxxx	uuuu uuuu	uuuu uuuu
ADRESL	PIC18F6X20	PIC18F8X20	xxxx xxxx	uuuu uuuu	uuuu uuuu
ADCON0	PIC18F6X20	PIC18F8X20	--00 0000	--00 0000	--uu uuuu
ADCON1	PIC18F6X20	PIC18F8X20	--00 0000	--00 0000	--uu uuuu
ADCON2	PIC18F6X20	PIC18F8X20	0--- -000	0--- -000	u--- -uuu
CCPR1H	PIC18F6X20	PIC18F8X20	xxxx xxxx	uuuu uuuu	uuuu uuuu
CCPR1L	PIC18F6X20	PIC18F8X20	xxxx xxxx	uuuu uuuu	uuuu uuuu
CCP1CON	PIC18F6X20	PIC18F8X20	--00 0000	--00 0000	--uu uuuu
CCPR2H	PIC18F6X20	PIC18F8X20	xxxx xxxx	uuuu uuuu	uuuu uuuu
CCPR2L	PIC18F6X20	PIC18F8X20	xxxx xxxx	uuuu uuuu	uuuu uuuu
CCP2CON	PIC18F6X20	PIC18F8X20	--00 0000	--00 0000	--uu uuuu
CCPR3H	PIC18F6X20	PIC18F8X20	xxxx xxxx	uuuu uuuu	uuuu uuuu
CCPR3L	PIC18F6X20	PIC18F8X20	xxxx xxxx	uuuu uuuu	uuuu uuuu
CCP3CON	PIC18F6X20	PIC18F8X20	0000 0000	0000 0000	uuuu uuuu
CVRCON	PIC18F6X20	PIC18F8X20	0000 0000	0000 0000	uuuu uuuu
CMCON	PIC18F6X20	PIC18F8X20	0000 0000	0000 0000	uuuu uuuu
TMR3H	PIC18F6X20	PIC18F8X20	xxxx xxxx	uuuu uuuu	uuuu uuuu
TMR3L	PIC18F6X20	PIC18F8X20	xxxx xxxx	uuuu uuuu	uuuu uuuu
T3CON	PIC18F6X20	PIC18F8X20	0000 0000	uuuu uuuu	uuuu uuuu
PSPCON	PIC18F6X20	PIC18F8X20	0000 ----	0000 ----	uuuu ----
SPBRG1	PIC18F6X20	PIC18F8X20	0000 0000	0000 0000	uuuu uuuu
RCREG1	PIC18F6X20	PIC18F8X20	0000 0000	0000 0000	uuuu uuuu
TXREG1	PIC18F6X20	PIC18F8X20	0000 0000	0000 0000	uuuu uuuu
TXSTA1	PIC18F6X20	PIC18F8X20	0000 -010	0000 -010	uuuu -uuu
RCSTA1	PIC18F6X20	PIC18F8X20	0000 000x	0000 000x	uuuu uuuu
EEADRH	PIC18F6X20	PIC18F8X20	---- --00	---- --00	---- --uu
EEADR	PIC18F6X20	PIC18F8X20	0000 0000	0000 0000	uuuu uuuu
EEDATA	PIC18F6X20	PIC18F8X20	0000 0000	0000 0000	uuuu uuuu
EECON2	PIC18F6X20	PIC18F8X20	---- ----	---- ----	---- ----
EECON1	PIC18F6X20	PIC18F8X20	xx-0 x000	uu-0 u000	uu-0 u000

Legend: u = unchanged, x = unknown, - = unimplemented bit, read as '0', q = value depends on condition.
Shaded cells indicate conditions do not apply for the designated device.

- Note 1:** One or more bits in the INTCONx or PIRx registers will be affected (to cause wake-up).
- 2:** When the wake-up is due to an interrupt and the GIEL or GIEH bit is set, the PC is loaded with the interrupt vector (0008h or 0018h).
 - 3:** When the wake-up is due to an interrupt and the GIEL or GIEH bit is set, the TOSU, TOSH and TOSL are updated with the current value of the PC. The STKPTR is modified to point to the next location in the hardware stack.
 - 4:** See Table 3-2 for Reset value for specific condition.
 - 5:** Bit 6 of PORTA, LATA and TRISA are enabled in ECIO and RCIO Oscillator modes only. In all other oscillator modes, they are disabled and read '0'.
 - 6:** Bit 6 of PORTA, LATA and TRISA are not available on all devices. When unimplemented, they are read '0'.

PIC18F6520/8520/6620/8620/6720/8720

TABLE 3-3: INITIALIZATION CONDITIONS FOR ALL REGISTERS (CONTINUED)

Register	Applicable Devices		Power-on Reset, Brown-out Reset	MCLR Resets WDT Reset RESET Instruction Stack Resets	Wake-up via WDT or Interrupt
IPR3	PIC18F6X20	PIC18F8X20	--11 1111	--11 1111	--uu uuuu
PIR3	PIC18F6X20	PIC18F8X20	--00 0000	--00 0000	--uu uuuu
PIE3	PIC18F6X20	PIC18F8X20	--00 0000	--00 0000	--uu uuuu
IPR2	PIC18F6X20	PIC18F8X20	-1-1 1111	-1-1 1111	-u-u uuuu
PIR2	PIC18F6X20	PIC18F8X20	-0-0 0000	-0-0 0000	-u-u uuuu ⁽¹⁾
PIE2	PIC18F6X20	PIC18F8X20	-0-0 0000	-0-0 0000	-u-u uuuu
IPR1	PIC18F6X20	PIC18F8X20	0111 1111	0111 1111	uuuu uuuu
PIR1	PIC18F6X20	PIC18F8X20	0000 0000	0000 0000	uuuu uuuu ⁽¹⁾
PIE1	PIC18F6X20	PIC18F8X20	0000 0000	0000 0000	uuuu uuuu
MEMCON	PIC18F6X20	PIC18F8X20	0-00 --00	0-00 --00	u-uu --uu
TRISJ	PIC18F6X20	PIC18F8X20	1111 1111	1111 1111	uuuu uuuu
TRISH	PIC18F6X20	PIC18F8X20	1111 1111	1111 1111	uuuu uuuu
TRISG	PIC18F6X20	PIC18F8X20	---1 1111	---1 1111	---u uuuu
TRISF	PIC18F6X20	PIC18F8X20	1111 1111	1111 1111	uuuu uuuu
TRISE	PIC18F6X20	PIC18F8X20	1111 1111	1111 1111	uuuu uuuu
TRISD	PIC18F6X20	PIC18F8X20	1111 1111	1111 1111	uuuu uuuu
TRISC	PIC18F6X20	PIC18F8X20	1111 1111	1111 1111	uuuu uuuu
TRISB	PIC18F6X20	PIC18F8X20	1111 1111	1111 1111	uuuu uuuu
TRISA ^(5,6)	PIC18F6X20	PIC18F8X20	-111 1111 ⁽⁵⁾	-111 1111 ⁽⁵⁾	-uuu uuuu ⁽⁵⁾
LATJ	PIC18F6X20	PIC18F8X20	xxxx xxxx	uuuu uuuu	uuuu uuuu
LATH	PIC18F6X20	PIC18F8X20	xxxx xxxx	uuuu uuuu	uuuu uuuu
LATG	PIC18F6X20	PIC18F8X20	---x xxxx	---u uuuu	---u uuuu
LATF	PIC18F6X20	PIC18F8X20	xxxx xxxx	uuuu uuuu	uuuu uuuu
LATE	PIC18F6X20	PIC18F8X20	xxxx xxxx	uuuu uuuu	uuuu uuuu
LATD	PIC18F6X20	PIC18F8X20	xxxx xxxx	uuuu uuuu	uuuu uuuu
LATC	PIC18F6X20	PIC18F8X20	xxxx xxxx	uuuu uuuu	uuuu uuuu
LATB	PIC18F6X20	PIC18F8X20	xxxx xxxx	uuuu uuuu	uuuu uuuu
LATA ^(5,6)	PIC18F6X20	PIC18F8X20	-xxx xxxx ⁽⁵⁾	-uuu uuuu ⁽⁵⁾	-uuu uuuu ⁽⁵⁾

Legend: u = unchanged, x = unknown, - = unimplemented bit, read as '0', q = value depends on condition. Shaded cells indicate conditions do not apply for the designated device.

- Note 1:** One or more bits in the INTCONx or PIRx registers will be affected (to cause wake-up).
- 2:** When the wake-up is due to an interrupt and the GIEL or GIEH bit is set, the PC is loaded with the interrupt vector (0008h or 0018h).
- 3:** When the wake-up is due to an interrupt and the GIEL or GIEH bit is set, the TOSU, TOSH and TOSL are updated with the current value of the PC. The STKPTR is modified to point to the next location in the hardware stack.
- 4:** See Table 3-2 for Reset value for specific condition.
- 5:** Bit 6 of PORTA, LATA and TRISA are enabled in ECIO and RCIO Oscillator modes only. In all other oscillator modes, they are disabled and read '0'.
- 6:** Bit 6 of PORTA, LATA and TRISA are not available on all devices. When unimplemented, they are read '0'.

PIC18F6520/8520/6620/8620/6720/8720

TABLE 3-3: INITIALIZATION CONDITIONS FOR ALL REGISTERS (CONTINUED)

Register	Applicable Devices		Power-on Reset, Brown-out Reset	MCLR Resets WDT Reset RESET Instruction Stack Resets	Wake-up via WDT or Interrupt
PORTJ	PIC18F6X20	PIC18F8X20	xxxx xxxx	uuuu uuuu	uuuu uuuu
PORTH	PIC18F6X20	PIC18F8X20	0000 xxxx	0000 uuuu	uuuu uuuu
PORTG	PIC18F6X20	PIC18F8X20	--x xxxx	uuuu uuuu	--u uuuu
PORTF	PIC18F6X20	PIC18F8X20	x000 0000	u000 0000	u000 0000
PORTE	PIC18F6X20	PIC18F8X20	xxxx xxxx	uuuu uuuu	uuuu uuuu
PORTD	PIC18F6X20	PIC18F8X20	xxxx xxxx	uuuu uuuu	uuuu uuuu
PORTC	PIC18F6X20	PIC18F8X20	xxxx xxxx	uuuu uuuu	uuuu uuuu
PORTB	PIC18F6X20	PIC18F8X20	xxxx xxxx	uuuu uuuu	uuuu uuuu
PORTA ^(5,6)	PIC18F6X20	PIC18F8X20	-x0x 0000 ⁽⁵⁾	-u0u 0000 ⁽⁵⁾	-uuu uuuu ⁽⁵⁾
TMR4	PIC18F6X20	PIC18F8X20	0000 0000	0000 0000	uuuu uuuu
PR4	PIC18F6X20	PIC18F8X20	1111 1111	1111 1111	uuuu uuuu
T4CON	PIC18F6X20	PIC18F8X20	-000 0000	-000 0000	-uuu uuuu
CCPR4H	PIC18F6X20	PIC18F8X20	xxxx xxxx	uuuu uuuu	uuuu uuuu
CCPR4L	PIC18F6X20	PIC18F8X20	xxxx xxxx	uuuu uuuu	uuuu uuuu
CCP4CON	PIC18F6X20	PIC18F8X20	0000 0000	0000 0000	uuuu uuuu
CCPR5H	PIC18F6X20	PIC18F8X20	xxxx xxxx	uuuu uuuu	uuuu uuuu
CCPR5L	PIC18F6X20	PIC18F8X20	xxxx xxxx	uuuu uuuu	uuuu uuuu
CCP5CON	PIC18F6X20	PIC18F8X20	0000 0000	0000 0000	uuuu uuuu
SPBRG2	PIC18F6X20	PIC18F8X20	0000 0000	0000 0000	uuuu uuuu
RCREG2	PIC18F6X20	PIC18F8X20	0000 0000	0000 0000	uuuu uuuu
TXREG2	PIC18F6X20	PIC18F8X20	0000 0000	0000 0000	uuuu uuuu
TXSTA2	PIC18F6X20	PIC18F8X20	0000 -010	0000 -010	uuuu -uuu
RCSTA2	PIC18F6X20	PIC18F8X20	0000 000x	0000 000x	uuuu uuuu

Legend: u = unchanged, x = unknown, - = unimplemented bit, read as '0', α = value depends on condition. Shaded cells indicate conditions do not apply for the designated device.

- Note 1:** One or more bits in the INTCONx or PIRx registers will be affected (to cause wake-up).
- 2:** When the wake-up is due to an interrupt and the GIEL or GIEH bit is set, the PC is loaded with the interrupt vector (0008h or 0018h).
- 3:** When the wake-up is due to an interrupt and the GIEL or GIEH bit is set, the TOSU, TOSH and TOSL are updated with the current value of the PC. The STKPTR is modified to point to the next location in the hardware stack.
- 4:** See Table 3-2 for Reset value for specific condition.
- 5:** Bit 6 of PORTA, LATA and TRISA are enabled in ECIO and RCIO Oscillator modes only. In all other oscillator modes, they are disabled and read '0'.
- 6:** Bit 6 of PORTA, LATA and TRISA are not available on all devices. When unimplemented, they are read '0'.

PIC18F6520/8520/6620/8620/6720/8720

FIGURE 3-3: TIME-OUT SEQUENCE ON POWER-UP ($\overline{\text{MCLR}}$ TIED TO V_{DD} VIA 1 k Ω RESISTOR)

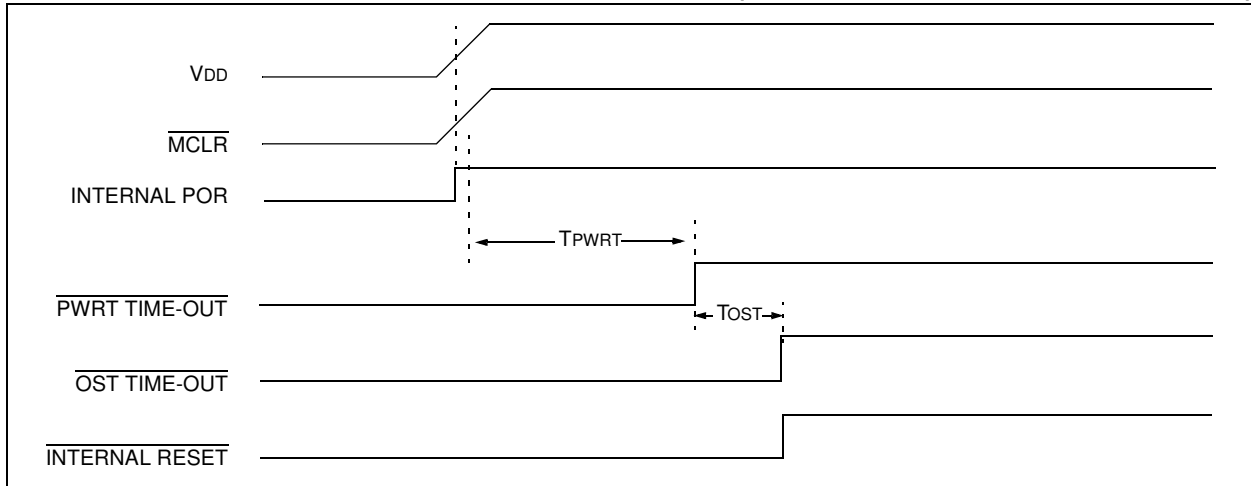

FIGURE 3-4: TIME-OUT SEQUENCE ON POWER-UP ($\overline{\text{MCLR}}$ NOT TIED TO V_{DD}): CASE 1

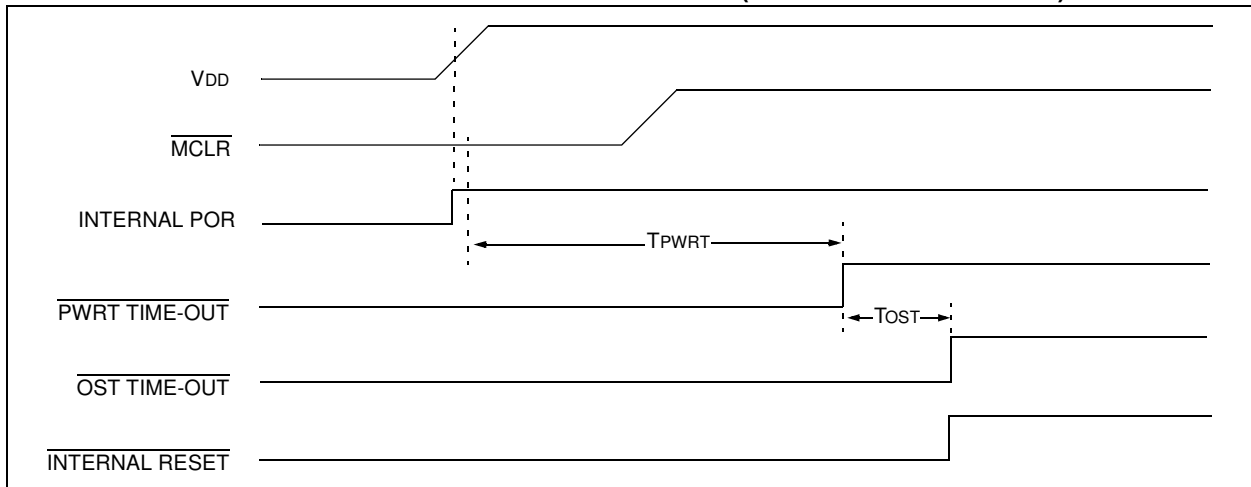
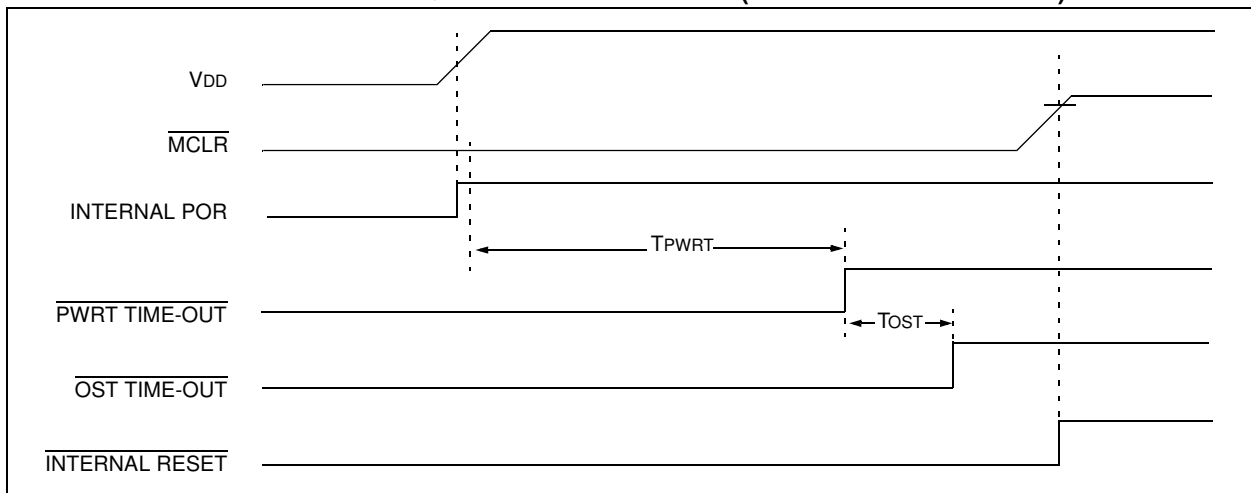

FIGURE 3-5: TIME-OUT SEQUENCE ON POWER-UP ($\overline{\text{MCLR}}$ NOT TIED TO V_{DD}): CASE 2



PIC18F6520/8520/6620/8620/6720/8720

FIGURE 3-6: SLOW RISE TIME ($\overline{\text{MCLR}}$ TIED TO V_{DD} VIA 1 k Ω RESISTOR)

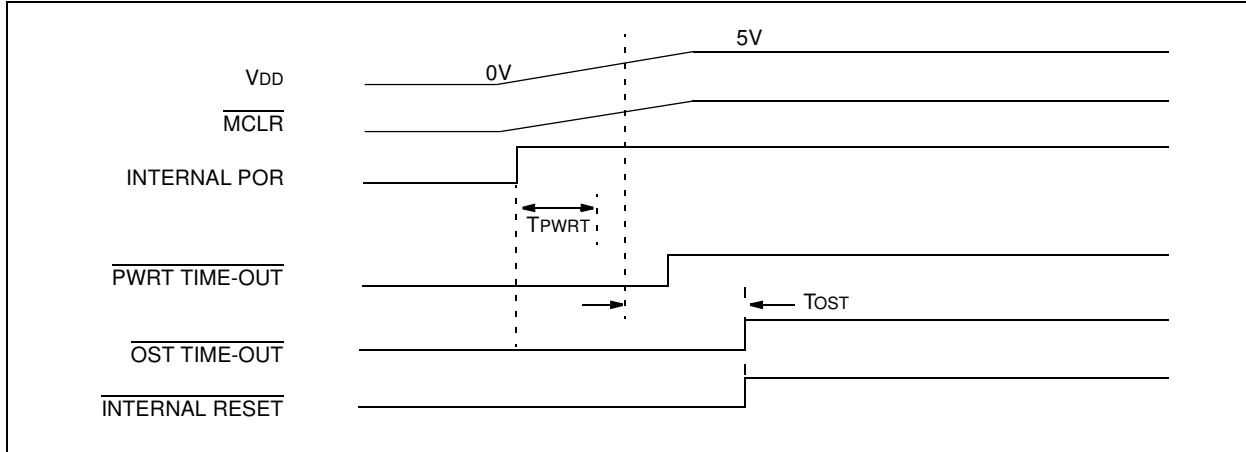
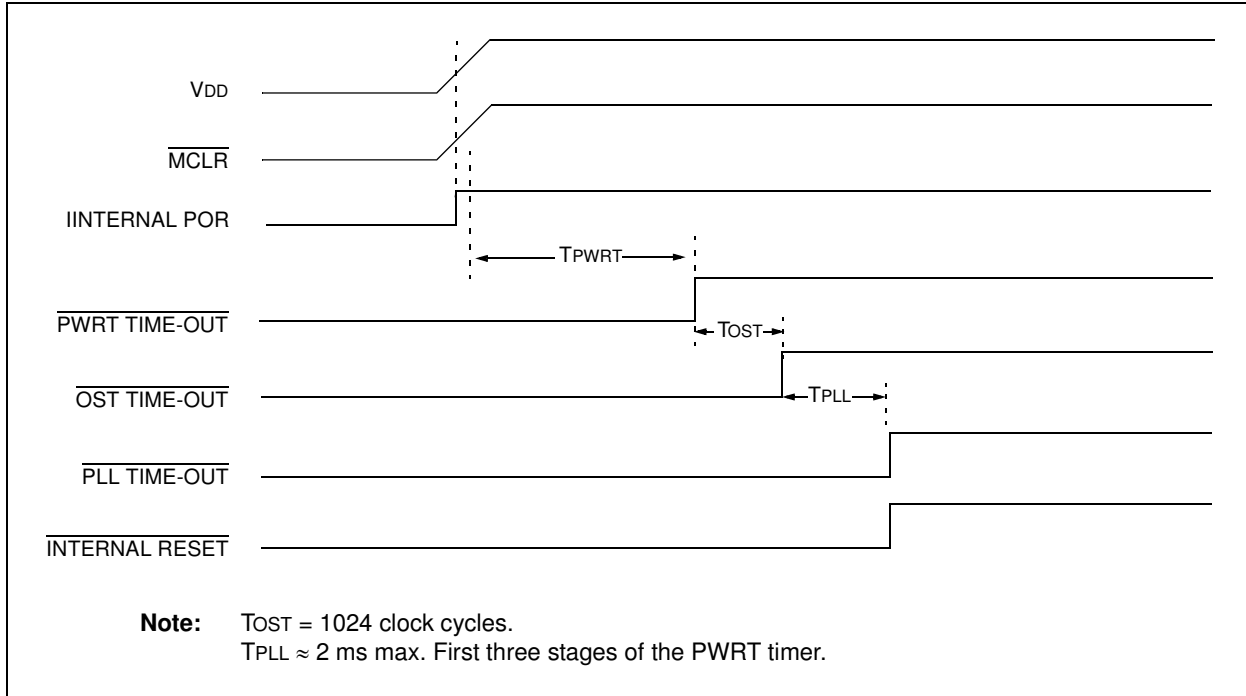

FIGURE 3-7: TIME-OUT SEQUENCE ON POR W/PLL ENABLED ($\overline{\text{MCLR}}$ TIED TO V_{DD} VIA 1 k Ω RESISTOR)



PIC18F6520/8520/6620/8620/6720/8720

4.0 MEMORY ORGANIZATION

There are three memory blocks in PIC18FXX20 devices. They are:

- Program Memory
- Data RAM
- Data EEPROM

Data and program memory use separate busses, which allows for concurrent access of these blocks. Additional detailed information for Flash program memory and data EEPROM is provided in **Section 5.0 “Flash Program Memory”** and **Section 7.0 “Data EEPROM Memory”**, respectively.

In addition to on-chip Flash, the PIC18F8X20 devices are also capable of accessing external program memory through an external memory bus. Depending on the selected operating mode (discussed in **Section 4.1.1 “PIC18F8X20 Program Memory Modes”**), the controllers may access either internal or external program memory exclusively, or both internal and external memory in selected blocks. Additional information on the External Memory Interface is provided in **Section 6.0 “External Memory Interface”**.

4.1 Program Memory Organization

A 21-bit program counter is capable of addressing the 2-Mbyte program memory space. Accessing a location between the physically implemented memory and the 2-Mbyte address will cause a read of all '0's (a NOP instruction).

Devices in the PIC18FXX20 family can be divided into three groups, based on program memory size. The PIC18FX520 devices (PIC18F6520 and PIC18F8520) have 32 Kbytes of on-chip Flash memory, equivalent to 16,384 single-word instructions. The PIC18FX620 devices (PIC18F6620 and PIC18F8620) have 64 Kbytes of on-chip Flash memory, equivalent to 32,768 single-word instructions. Finally, the PIC18FX720 devices (PIC18F6720 and PIC18F8720) have 128 Kbytes of on-chip Flash memory, equivalent to 65,536 single-word instructions.

For all devices, the Reset vector address is at 0000h and the interrupt vector addresses are at 0008h and 0018h.

The program memory maps for all of the PIC18FXX20 devices are compared in Figure 4-1.

4.1.1 PIC18F8X20 PROGRAM MEMORY MODES

PIC18F8X20 devices differ significantly from their PIC18 predecessors in their utilization of program memory. In addition to available on-chip Flash program memory, these controllers can also address up to 2 Mbytes of external program memory through the External Memory Interface. There are four distinct operating modes available to the controllers:

- Microprocessor (MP)
- Microprocessor with Boot Block (MPBB)
- Extended Microcontroller (EMC)
- Microcontroller (MC)

The Program Memory mode is determined by setting the two Least Significant bits of the CONFIG3L configuration byte, as shown in Register 4-1. (See also **Section 23.1 “Configuration Bits”** for additional details on the device configuration bits.)

The Program Memory modes operate as follows:

- The **Microprocessor Mode** permits access only to external program memory; the contents of the on-chip Flash memory are ignored. The 21-bit program counter permits access to a 2-Mbyte linear program memory space.
- The **Microprocessor with Boot Block Mode** accesses on-chip Flash memory from addresses 000000h to 0007FFh for PIC18F8520 devices and from 000000h to 0001FFh for PIC18F8620 and PIC18F8720 devices. Above this, external program memory is accessed all the way up to the 2-Mbyte limit. Program execution automatically switches between the two memories, as required.
- The **Microcontroller Mode** accesses only on-chip Flash memory. Attempts to read above the physical limit of the on-chip Flash (7FFFh for the PIC18F8520, 0FFFFh for the PIC18F8620, 1FFFFh for the PIC18F8720) causes a read of all '0's (a NOP instruction). The Microcontroller mode is also the only operating mode available to PIC18F6X20 devices.
- The **Extended Microcontroller Mode** allows access to both internal and external program memories as a single block. The device can access its entire on-chip Flash memory; above this, the device accesses external program memory up to the 2-Mbyte program space limit. As with Boot Block mode, execution automatically switches between the two memories, as required.

In all modes, the microcontroller has complete access to data RAM and EEPROM.

Figure 4-2 compares the memory maps of the different Program Memory modes. The differences between on-chip and external memory access limitations are more fully explained in Table 4-1.

PIC18F6520/8520/6620/8620/6720/8720

FIGURE 4-1: INTERNAL PROGRAM MEMORY MAP AND STACK FOR PIC18FXX20 DEVICES

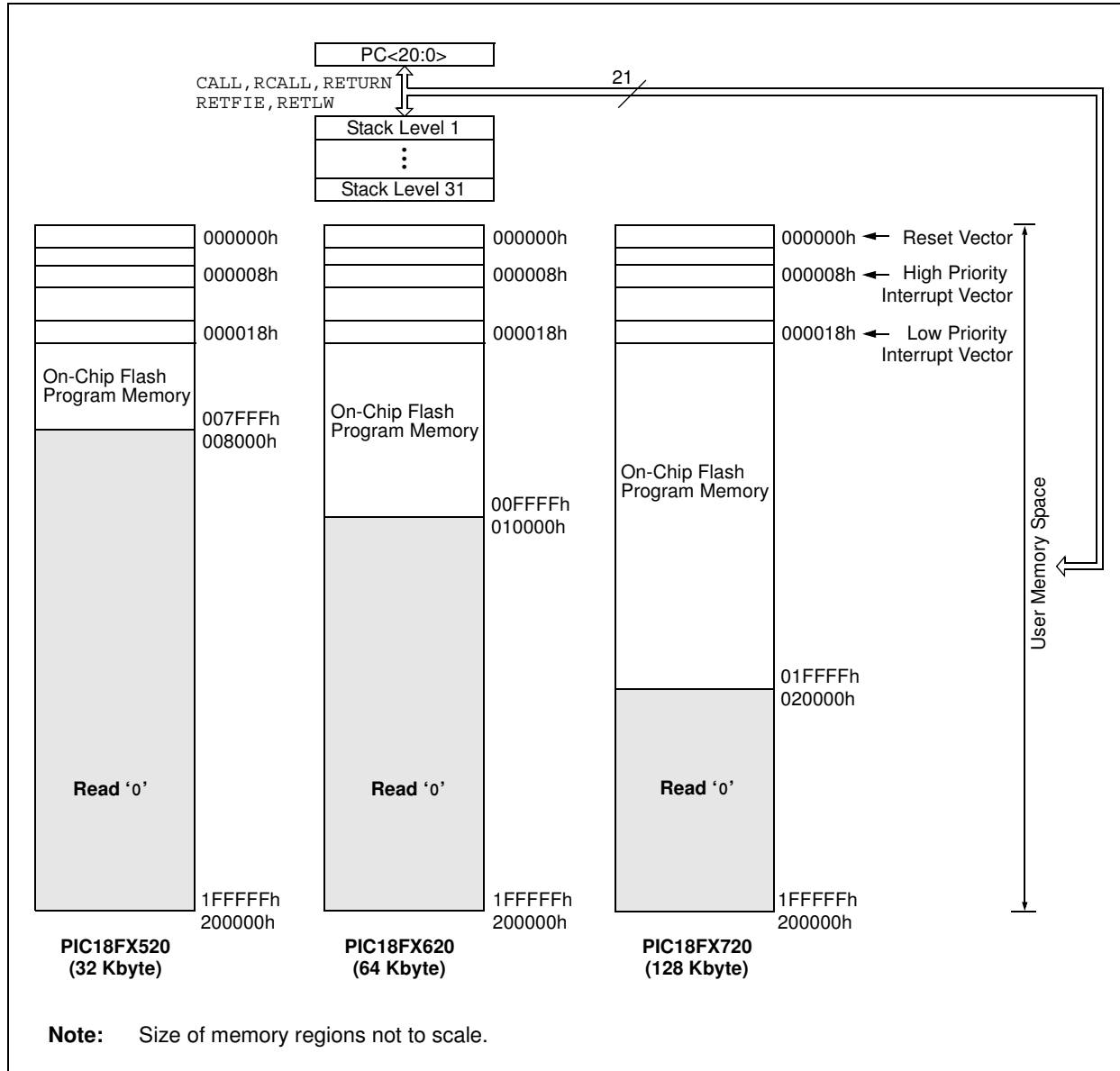

TABLE 4-1: MEMORY ACCESS FOR PIC18F8X20 PROGRAM MEMORY MODES

Operating Mode	Internal Program Memory			External Program Memory		
	Execution From	Table Read From	Table Write To	Execution From	Table Read From	Table Write To
Microprocessor	No Access	No Access	No Access	Yes	Yes	Yes
Microprocessor with Boot Block	Yes	Yes	Yes	Yes	Yes	Yes
Microcontroller	Yes	Yes	Yes	No Access	No Access	No Access
Extended Microcontroller	Yes	Yes	Yes	Yes	Yes	Yes

PIC18F6520/8520/6620/8620/6720/8720

REGISTER 4-1: CONFIG3L CONFIGURATION BYTE

R/P-1	U-0	U-0	U-0	U-0	U-0	R/P-1	R/P-1	
WAIT	—	—	—	—	—	PM1	PM0	
bit 7							bit 0	

- bit 7 **WAIT:** External Bus Data Wait Enable bit
 1 = Wait selections unavailable, device will not wait
 0 = Wait programmed by WAIT1 and WAIT0 bits of MEMCOM register (MEMCOM<5:4>)
- bit 6-2 **Unimplemented:** Read as '0'
- bit 1-0 **PM1:PM0:** Processor Data Memory Mode Select bits
 11 = Microcontroller mode
 10 = Microprocessor mode
 01 = Microcontroller with Boot Block mode
 00 = Extended Microcontroller mode

Legend:

R = Readable bit P = Programmable bit U = Unimplemented bit, read as '0'
 - n = Value after erase '1' = Bit is set '0' = Bit is cleared x = Bit is unknown

FIGURE 4-2: MEMORY MAPS FOR PIC18F8X20 PROGRAM MEMORY MODES

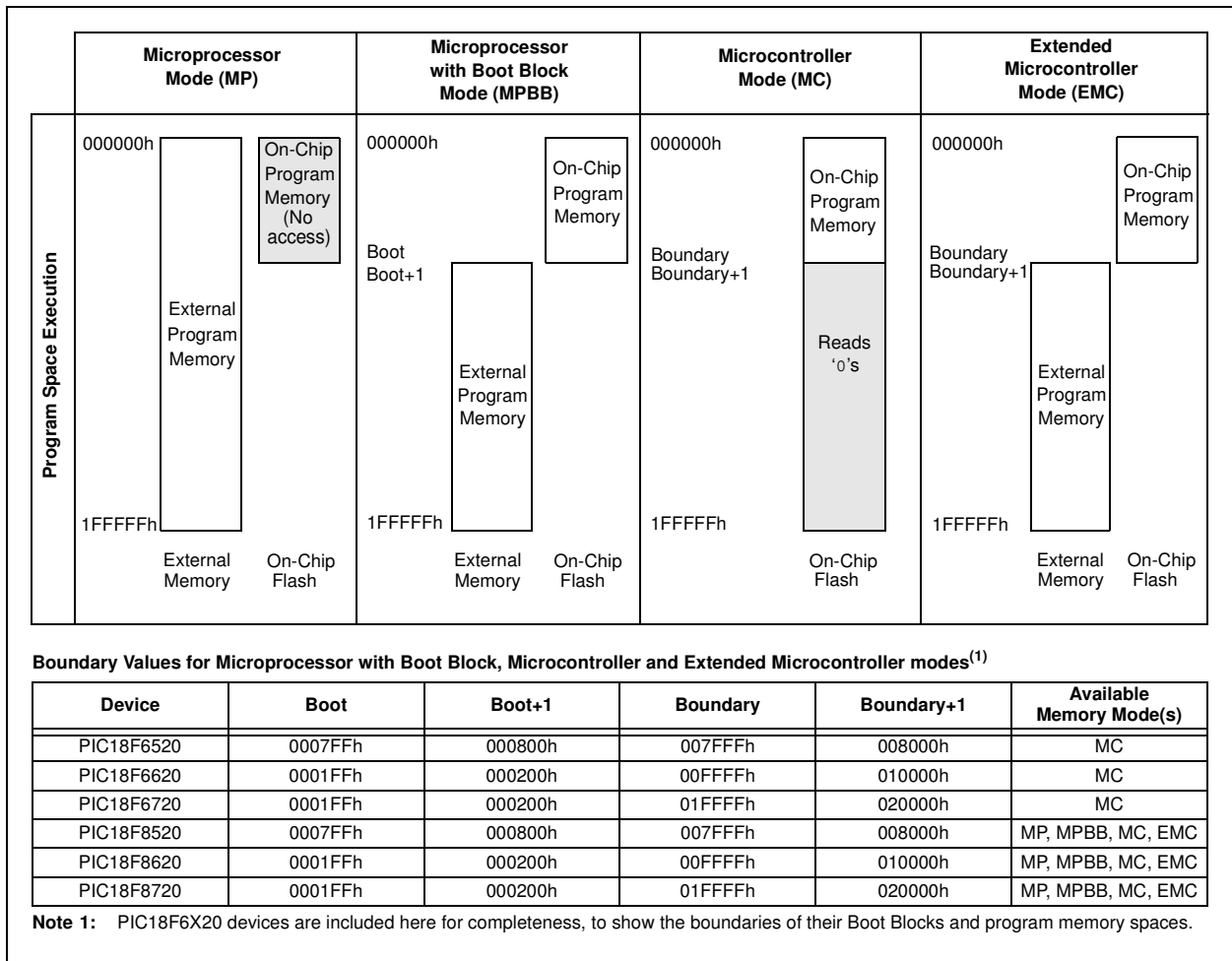

PIC18F6520/8520/6620/8620/6720/8720

4.2 Return Address Stack

The return address stack allows any combination of up to 31 program calls and interrupts to occur. The PC (Program Counter) is pushed onto the stack when a `CALL` or `RCALL` instruction is executed, or an interrupt is Acknowledged. The PC value is pulled off the stack on a `RETURN`, `RETLW` or a `RETFIE` instruction. `PCLATU` and `PCLATH` are not affected by any of the `RETURN` or `CALL` instructions.

The stack operates as a 31-word by 21-bit RAM and a 5-bit stack pointer, with the stack pointer initialized to 00000b after all Resets. There is no RAM associated with stack pointer 00000b. This is only a Reset value. During a `CALL` type instruction, causing a push onto the stack, the stack pointer is first incremented and the RAM location pointed to by the stack pointer is written with the contents of the PC. During a `RETURN` type instruction, causing a pop from the stack, the contents of the RAM location pointed to by the `STKPTR` are transferred to the PC and then the stack pointer is decremented.

The stack space is not part of either program or data space. The stack pointer is readable and writable and the address on the top of the stack is readable and writable through SFR registers. Data can also be pushed to, or popped from the stack using the top-of-stack SFRs. Status bits indicate if the stack pointer is at, or beyond the 31 levels provided.

4.2.1 TOP-OF-STACK ACCESS

The top of the stack is readable and writable. Three register locations, `TOSU`, `TOSH` and `TOSL`, hold the contents of the stack location pointed to by the `STKPTR` register. This allows users to implement a software stack if necessary. After a `CALL`, `RCALL` or interrupt, the software can read the pushed value by reading the `TOSU`, `TOSH` and `TOSL` registers. These values can be placed on a user defined software stack. At return time, the software can replace the `TOSU`, `TOSH` and `TOSL` and do a return.

The user must disable the global interrupt enable bits during this time to prevent inadvertent stack operations.

4.2.2 RETURN STACK POINTER (STKPTR)

The `STKPTR` register contains the stack pointer value, the `STKFUL` (Stack Full) status bit and the `STKUNF` (Stack Underflow) status bits. Register 4-2 shows the `STKPTR` register. The value of the stack pointer can be 0 through 31. The stack pointer increments when values are pushed onto the stack and decrements when values are popped off the stack. At Reset, the stack pointer value will be '0'. The user may read and write the stack pointer value. This feature can be used by a Real-Time Operating System for return stack maintenance.

After the PC is pushed onto the stack 31 times (without popping any values off the stack), the `STKFUL` bit is set. The `STKFUL` bit can only be cleared in software or by a POR.

The action that takes place when the stack becomes full, depends on the state of the `STVREN` (Stack Overflow Reset Enable) configuration bit. Refer to **Section 24.0 "Instruction Set Summary"** for a description of the device configuration bits. If `STVREN` is set (default), the 31st push will push the `(PC + 2)` value onto the stack, set the `STKFUL` bit and reset the device. The `STKFUL` bit will remain set and the stack pointer will be set to '0'.

If `STVREN` is cleared, the `STKFUL` bit will be set on the 31st push and the stack pointer will increment to 31. Any additional pushes will not overwrite the 31st push and `STKPTR` will remain at 31.

When the stack has been popped enough times to unload the stack, the next pop will return a value of zero to the PC and sets the `STKUNF` bit, while the stack pointer remains at '0'. The `STKUNF` bit will remain set until cleared in software or a POR occurs.

Note: Returning a value of zero to the PC on an underflow has the effect of vectoring the program to the Reset vector, where the stack conditions can be verified and appropriate actions can be taken.

PIC18F6520/8520/6620/8620/6720/8720

REGISTER 4-2: STKPTR REGISTER

R/C-0	R/C-0	U-0	R/W-0	R/W-0	R/W-0	R/W-0	R/W-0	
STKFUL ⁽¹⁾	STKUNF ⁽¹⁾	—	SP4	SP3	SP2	SP1	SP0	
bit 7								bit 0

- bit 7 **STKFUL:** Stack Full Flag bit
1 = Stack became full or overflowed
0 = Stack has not become full or overflowed
- bit 6 **STKUNF:** Stack Underflow Flag bit
1 = Stack underflow occurred
0 = Stack underflow did not occur
- bit 5 **Unimplemented:** Read as '0'
- bit 4-0 **SP4:SP0:** Stack Pointer Location bits

Note 1: Bit 7 and bit 6 can only be cleared in user software or by a POR.

Legend:

R = Readable bit W = Writable bit U = Unimplemented bit, read as '0'
 - n = Value at POR '1' = Bit is set '0' = Bit is cleared x = Bit is unknown

FIGURE 4-3: RETURN ADDRESS STACK AND ASSOCIATED REGISTERS

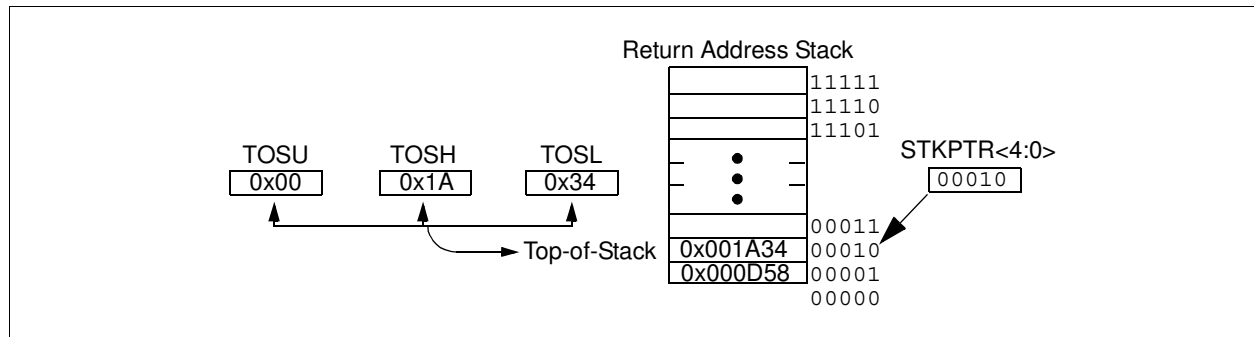

4.2.3 PUSH AND POP INSTRUCTIONS

Since the Top-of-Stack (TOS) is readable and writable, the ability to push values onto the stack and pull values off the stack, without disturbing normal program execution, is a desirable option. To push the current PC value onto the stack, a `PUSH` instruction can be executed. This will increment the stack pointer and load the current PC value onto the stack. TOSU, TOSH and TOSL can then be modified to place a return address on the stack.

The ability to pull the TOS value off of the stack and replace it with the value that was previously pushed onto the stack, without disturbing normal execution, is achieved by using the `POP` instruction. The `POP` instruction discards the current TOS by decrementing the stack pointer. The previous value pushed onto the stack then becomes the TOS value.

4.2.4 STACK FULL/UNDERFLOW RESETS

These Resets are enabled by programming the `STVREN` configuration bit. When the `STVREN` bit is disabled, a full or underflow condition will set the appropriate `STKFUL` or `STKUNF` bit, but not cause a device Reset. When the `STVREN` bit is enabled, a full or underflow condition will set the appropriate `STKFUL` or `STKUNF` bit and then cause a device Reset. The `STKFUL` or `STKUNF` bits are only cleared by the user software or a POR Reset.

PIC18F6520/8520/6620/8620/6720/8720

4.3 Fast Register Stack

A “fast interrupt return” option is available for interrupts. A Fast Register Stack is provided for the Status, WREG and BSR registers and is only one in depth. The stack is not readable or writable and is loaded with the current value of the corresponding register when the processor vectors for an interrupt. The values in the registers are then loaded back into the working registers, if the `FAST RETURN` instruction is used to return from the interrupt.

A low or high priority interrupt source will push values into the stack registers. If both low and high priority interrupts are enabled, the stack registers cannot be used reliably for low priority interrupts. If a high priority interrupt occurs while servicing a low priority interrupt, the stack register values stored by the low priority interrupt will be overwritten.

If high priority interrupts are not disabled during low priority interrupts, users must save the key registers in software during a low priority interrupt.

If no interrupts are used, the fast register stack can be used to restore the Status, WREG and BSR registers at the end of a subroutine call. To use the fast register stack for a subroutine call, a `FAST CALL` instruction must be executed.

Example 4-1 shows a source code example that uses the fast register stack.

EXAMPLE 4-1: FAST REGISTER STACK CODE EXAMPLE

```
CALL SUB1, FAST ;STATUS, WREG, BSR
                  ;SAVED IN FAST REGISTER
                  ;STACK
.
.
SUB1 .
.
RETURN FAST ;RESTORE VALUES SAVED
          ;IN FAST REGISTER STACK
```

4.4 PCL, PCLATH and PCLATU

The program counter (PC) specifies the address of the instruction to fetch for execution. The PC is 21 bits wide. The low byte is called the PCL register; this register is readable and writable. The high byte is called the PCH register. This register contains the PC<15:8> bits and is not directly readable or writable; updates to the PCH register may be performed through the PCLATH register. The upper byte is called PCU. This register contains the PC<20:16> bits and is not directly readable or writable; updates to the PCU register may be performed through the PCLATU register.

The PC addresses bytes in the program memory. To prevent the PC from becoming misaligned with word instructions, the LSB of the PCL is fixed to a value of ‘0’. The PC increments by 2 to address sequential instructions in the program memory.

The `CALL`, `RCALL`, `GOTO` and program branch instructions write to the program counter directly. For these instructions, the contents of PCLATH and PCLATU are not transferred to the program counter.

The contents of PCLATH and PCLATU will be transferred to the program counter by an operation that writes PCL. Similarly, the upper two bytes of the program counter will be transferred to PCLATH and PCLATU by an operation that reads PCL. This is useful for computed offsets to the PC (see **Section 4.8.1 “Computed GOTO”**).

4.5 Clocking Scheme/Instruction Cycle

The clock input (from OSC1) is internally divided by four to generate four non-overlapping quadrature clocks, namely Q1, Q2, Q3 and Q4. Internally, the program counter (PC) is incremented every Q1, the instruction is fetched from the program memory and latched into the instruction register in Q4. The instruction is decoded and executed during the following Q1 through Q4. The clocks and instruction execution flow are shown in Figure 4-4.

FIGURE 4-4: CLOCK/INSTRUCTION CYCLE

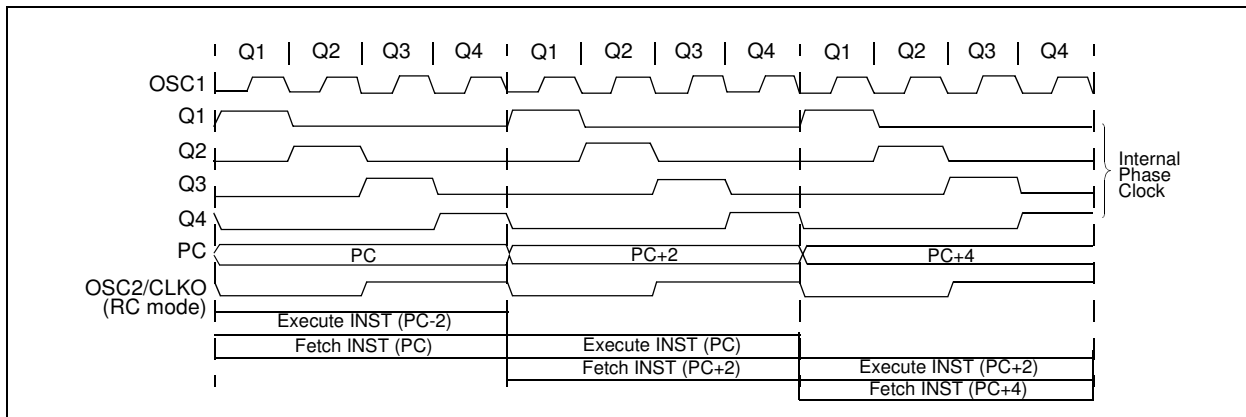

PIC18F6520/8520/6620/8620/6720/8720

4.6 Instruction Flow/Pipelining

An "Instruction Cycle" consists of four Q cycles (Q1, Q2, Q3 and Q4). The instruction fetch and execute are pipelined, such that fetch takes one instruction cycle, while decode and execute takes another instruction cycle. However, due to the pipelining, each instruction effectively executes in one cycle. If an instruction causes the program counter to change (e.g., GOTO), then two cycles are required to complete the instruction (Example 4-2).

A fetch cycle begins with the program counter (PC) incrementing in Q1.

In the execution cycle, the fetched instruction is latched into the "Instruction Register" (IR) in cycle Q1. This instruction is then decoded and executed during the Q2, Q3 and Q4 cycles. Data memory is read during Q2 (operand read) and written during Q4 (destination write).

EXAMPLE 4-2: INSTRUCTION PIPELINE FLOW

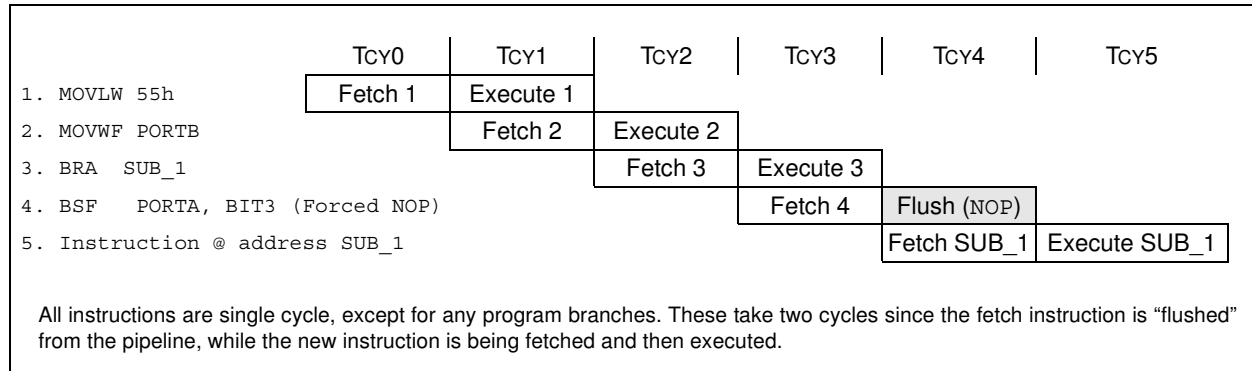

4.7 Instructions in Program Memory

The program memory is addressed in bytes. Instructions are stored as two bytes or four bytes in program memory. The Least Significant Byte of an instruction word is always stored in a program memory location with an even address (LSB = 0). Figure 4-5 shows an example of how instruction words are stored in the program memory. To maintain alignment with instruction boundaries, the PC increments in steps of 2 and the LSB will always read '0' (see Section 4.4 "PCL, PCLATH and PCLATU").

word boundaries, the data contained in the instruction is a word address. The word address is written to PC<20:1>, which accesses the desired byte address in program memory. Instruction #2 in Figure 4-5 shows how the instruction "GOTO 000006h" is encoded in the program memory. Program branch instructions, which encode a relative address offset, operate in the same manner. The offset value stored in a branch instruction represents the number of single-word instructions that the PC will be offset by. Section 24.0 "Instruction Set Summary" provides further details of the instruction set.

The CALL and GOTO instructions have an absolute program memory address embedded into the instruction. Since instructions are always stored on

FIGURE 4-5: INSTRUCTIONS IN PROGRAM MEMORY

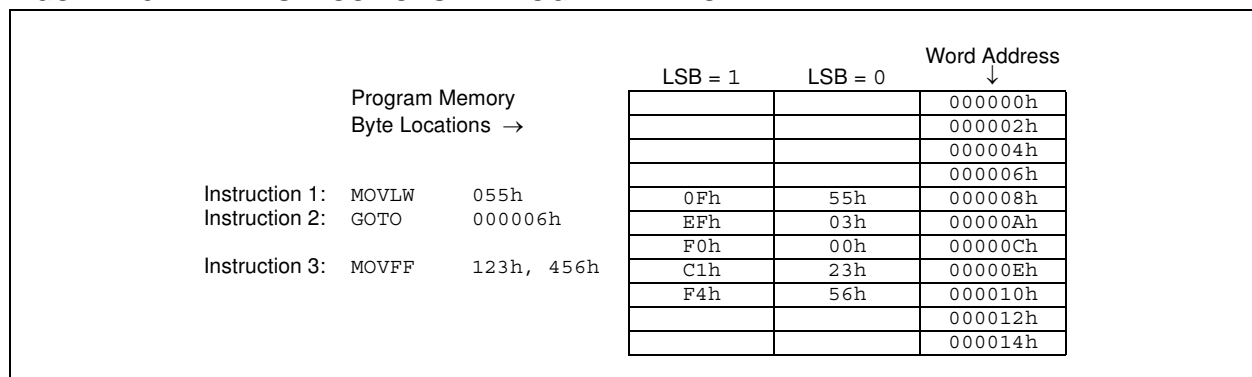

PIC18F6520/8520/6620/8620/6720/8720

4.7.1 TWO-WORD INSTRUCTIONS

The PIC18FXX20 devices have four two-word instructions: `MOVFF`, `CALL`, `GOTO` and `LFSR`. The second word of these instructions has the 4 MSBs set to '1's and is a special kind of `NOP` instruction. The lower 12 bits of the second word contain data to be used by the instruction. If the first word of the instruction is executed, the data in the second word is accessed. If the second

word of the instruction is executed by itself (first word was skipped), it will execute as a `NOP`. This action is necessary when the two-word instruction is preceded by a conditional instruction that changes the PC. A program example that demonstrates this concept is shown in Example 4-3. Refer to **Section 24.0 "Instruction Set Summary"** for further details of the instruction set.

EXAMPLE 4-3: TWO-WORD INSTRUCTIONS

CASE 1:	
Object Code	Source Code
0110 0110 0000 0000	TSTFSZ REG1 ; is RAM location 0?
1100 0001 0010 0011	MOVFF REG1, REG2 ; No, execute 2-word instruction
1111 0100 0101 0110	; 2nd operand holds address of REG2
0010 0100 0000 0000	ADDWF REG3 ; continue code
CASE 2:	
Object Code	Source Code
0110 0110 0000 0000	TSTFSZ REG1 ; is RAM location 0?
1100 0001 0010 0011	MOVFF REG1, REG2 ; Yes
1111 0100 0101 0110	; 2nd operand becomes NOP
0010 0100 0000 0000	ADDWF REG3 ; continue code

4.8 Look-up Tables

Look-up tables are implemented two ways. These are:

- Computed `GOTO`
- Table Reads

4.8.1 COMPUTED GOTO

A computed `GOTO` is accomplished by adding an offset to the program counter (`ADDWF PCL`).

A look-up table can be formed with an `ADDWF PCL` instruction and a group of `RETLW 0xnn` instructions. `WREG` is loaded with an offset into the table before executing a call to that table. The first instruction of the called routine is the `ADDWF PCL` instruction. The next instruction executed will be one of the `RETLW 0xnn` instructions, that returns the value `0xnn` to the calling function.

The offset value (value in `WREG`) specifies the number of bytes that the program counter should advance.

In this method, only one data byte may be stored in each instruction location and room on the return address stack is required.

4.8.2 TABLE READS/TABLE WRITES

A better method of storing data in program memory allows 2 bytes of data to be stored in each instruction location.

Look-up table data may be stored 2 bytes per program word by using table reads and writes. The Table Pointer (`TBLPTR`) specifies the byte address and the Table Latch (`TABLAT`) contains the data that is read from, or written to program memory. Data is transferred to/from program memory, one byte at a time.

A description of the table read/table write operation is shown in **Section 5.0 "Flash Program Memory"**.

4.9 Data Memory Organization

The data memory is implemented as static RAM. Each register in the data memory has a 12-bit address, allowing up to 4096 bytes of data memory. The data memory map is in turn divided into 16 banks of 256 bytes each. The lower 4 bits of the Bank Select Register (BSR<3:0>) select which bank will be accessed. The upper 4 bits of the BSR are not implemented.

The data memory space contains both Special Function Registers (SFR) and General Purpose Registers (GPR). The SFRs are used for control and status of the controller and peripheral functions, while GPRs are used for data storage and scratch pad operations in the user's application. The SFRs start at the last location of Bank 15 (0FFFh) and extend downwards. Any remaining space beyond the SFRs in the Bank may be implemented as GPRs. GPRs start at the first location of Bank 0 and grow upwards. Any read of an unimplemented location will read as '0's.

PIC18FX520 devices have 2048 bytes of data RAM, extending from Bank 0 to Bank 7 (000h through 7FFh). PIC18FX620 and PIC18FX720 devices have 3840 bytes of data RAM, extending from Bank 0 to Bank 14 (000h through EFFh). The organization of the data memory space for these devices is shown in Figure 4-6 and Figure 4-7.

The entire data memory may be accessed directly or indirectly. Direct addressing may require the use of the BSR register. Indirect addressing requires the use of a File Select Register (FSRn) and a corresponding Indirect File Operand (INDFn). Each FSR holds a 12-bit address value that can be used to access any location in the data memory map without banking.

The instruction set and architecture allow operations across all banks. This may be accomplished by indirect addressing, or by the use of the MOVFF instruction. The MOVFF instruction is a two-word/two-cycle instruction that moves a value from one register to another.

To ensure that commonly used registers (SFRs and select GPRs) can be accessed in a single cycle, regardless of the current BSR values, an Access Bank is implemented. A segment of Bank 0 and a segment of Bank 15 comprise the Access RAM. **Section 4.10 "Access Bank"** provides a detailed description of the Access RAM.

4.9.1 GENERAL PURPOSE REGISTER FILE

The register file can be accessed either directly or indirectly. Indirect addressing operates using a File Select Register and corresponding Indirect File Operand. The operation of indirect addressing is shown in **Section 4.12 "Indirect Addressing, INDF and FSR Registers"**.

Enhanced MCU devices may have banked memory in the GPR area. GPRs are not initialized by a Power-on Reset and are unchanged on all other Resets.

Data RAM is available for use as General Purpose Registers by all instructions. The top section of Bank 15 (F60h to FFFh) contains SFRs. All other banks of data memory contain GPR registers, starting with Bank 0.

4.9.2 SPECIAL FUNCTION REGISTERS

The Special Function Registers (SFRs) are registers used by the CPU and peripheral modules for controlling the desired operation of the device. These registers are implemented as static RAM. A list of these registers is given in Table 4-2 and Table 4-3.

The SFRs can be classified into two sets: those associated with the "core" function and those related to the peripheral functions. Those registers related to the "core" are described in this section, while those related to the operation of the peripheral features are described in the section of that peripheral feature. The SFRs are typically distributed among the peripherals whose functions they control.

The unused SFR locations are unimplemented and read as '0's. The addresses for the SFRs are listed in Table 4-2.

PIC18F6520/8520/6620/8620/6720/8720

FIGURE 4-6: DATA MEMORY MAP FOR PIC18FX520 DEVICES

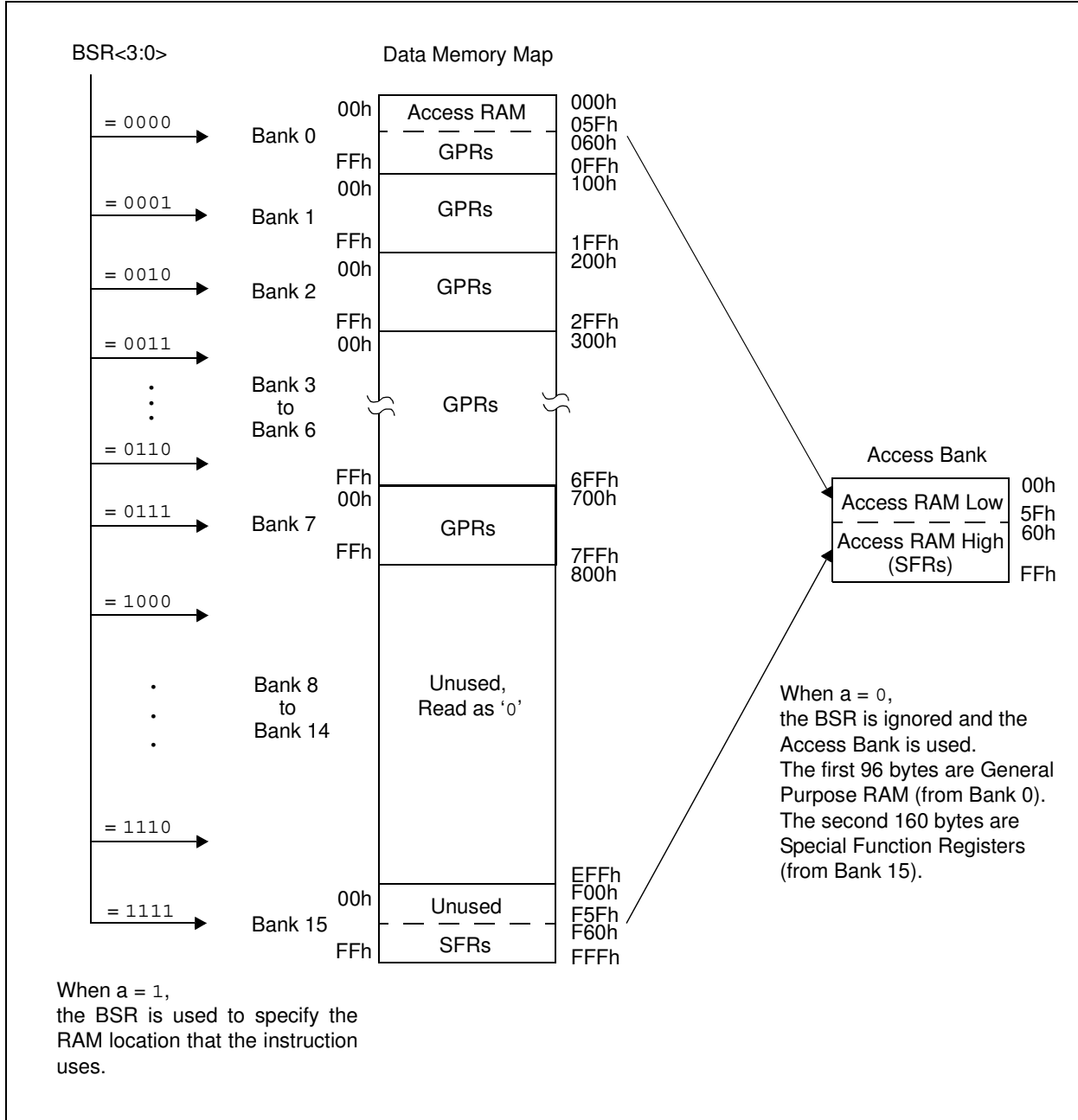

PIC18F6520/8520/6620/8620/6720/8720

FIGURE 4-7: DATA MEMORY MAP FOR PIC18FX620 AND PIC18FX720 DEVICES

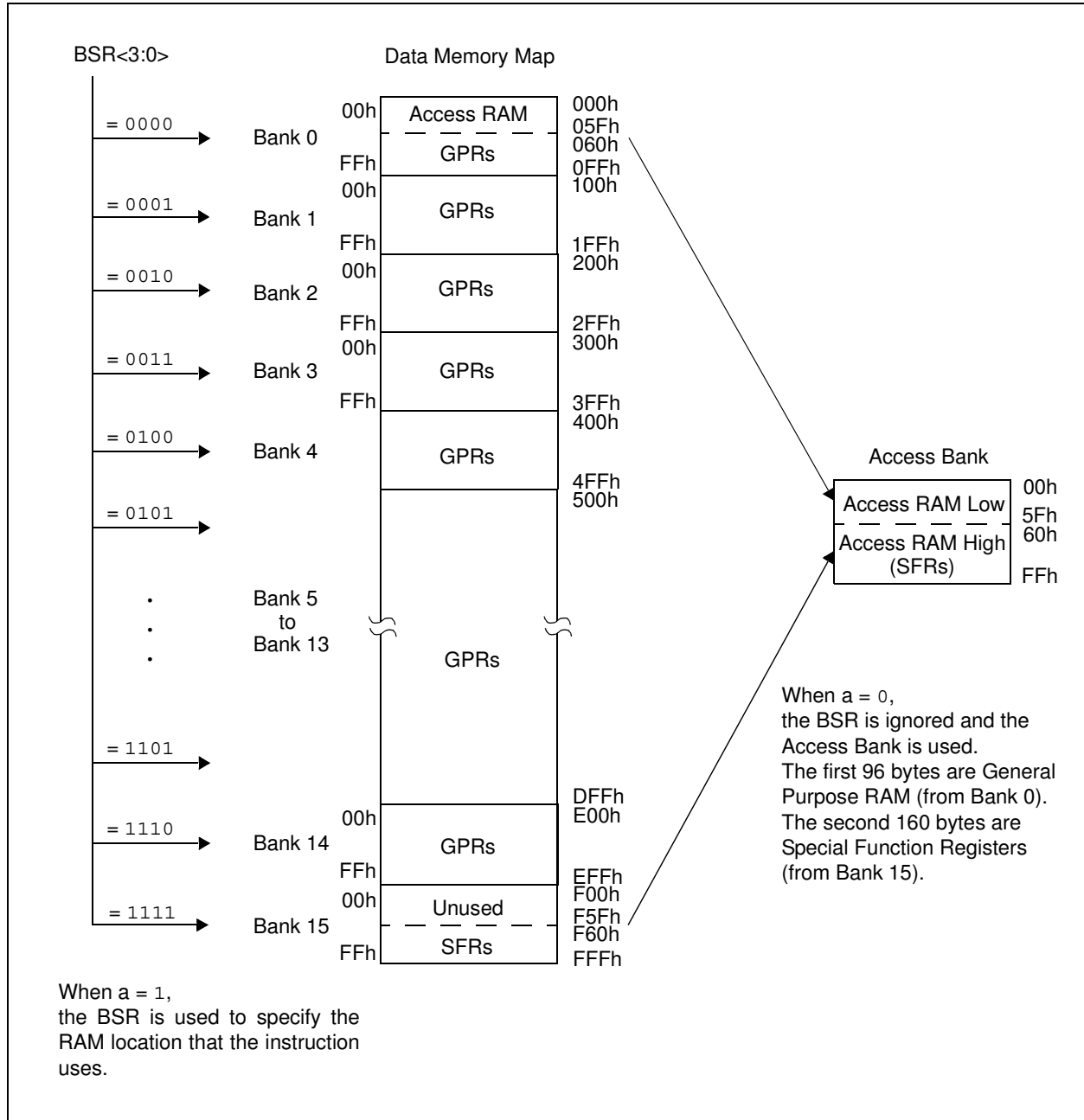

PIC18F6520/8520/6620/8620/6720/8720

TABLE 4-2: SPECIAL FUNCTION REGISTER MAP

Address	Name	Address	Name	Address	Name	Address	Name
FFFh	TOSU	FDFh	INDF2 ⁽³⁾	FBFh	CCPR1H	F9Fh	IPR1
FFEh	TOSH	FDEh	POSTINC2 ⁽³⁾	FBEh	CCPR1L	F9Eh	PIR1
FFDh	TOSL	FDDh	POSTDEC2 ⁽³⁾	FBDh	CCP1CON	F9Dh	PIE1
FFCh	STKPTR	FDCh	PREINC2 ⁽³⁾	FBCh	CCPR2H	F9Ch	MEMCON ⁽²⁾
FFBh	PCLATU	FDBh	PLUSW2 ⁽³⁾	FBHh	CCPR2L	F9Bh	— ⁽¹⁾
FFAh	PCLATH	FDAh	FSR2H	FBAh	CCP2CON	F9Ah	TRISJ
FF9h	PCL	FD9h	FSR2L	FB9h	CCPR3H	F99h	TRISH
FF8h	TBLPTRU	FD8h	STATUS	FB8h	CCPR3L	F98h	TRISG
FF7h	TBLPTRH	FD7h	TMR0H	FB7h	CCP3CON	F97h	TRISF
FF6h	TBLPTRL	FD6h	TMR0L	FB6h	— ⁽¹⁾	F96h	TRISE
FF5h	TABLAT	FD5h	T0CON	FB5h	CVRCON	F95h	TRISD
FF4h	PRODH	FD4h	— ⁽¹⁾	FB4h	CMCON	F94h	TRISC
FF3h	PRODL	FD3h	OSCCON	FB3h	TMR3H	F93h	TRISB
FF2h	INTCON	FD2h	LVDCON	FB2h	TMR3L	F92h	TRISA
FF1h	INTCON2	FD1h	WDTCON	FB1h	T3CON	F91h	LATJ
FF0h	INTCON3	FD0h	RCON	FB0h	PSPCON	F90h	LATH
FEFh	INDF0 ⁽³⁾	FCFh	TMR1H	FAFh	SPBRG1	F8Fh	LATG
FEeh	POSTINC0 ⁽³⁾	FCEh	TMR1L	FAEh	RCREG1	F8Eh	LATF
FEDh	POSTDEC0 ⁽³⁾	FCDh	T1CON	FADh	TXREG1	F8Dh	LATE
FECh	PREINC0 ⁽³⁾	FCCh	TMR2	FACH	TXSTA1	F8Ch	LATD
FEbh	PLUSW0 ⁽³⁾	FCBh	PR2	FABh	RCSTA1	F8Bh	LATC
FEAh	FSR0H	FCAh	T2CON	FAAh	EEADRH	F8Ah	LATB
FE9h	FSR0L	FC9h	SSPBUF	FA9h	EEADR	F89h	LATA
FE8h	WREG	FC8h	SSPADD	FA8h	EEDATA	F88h	PORTJ
FE7h	INDF1 ⁽³⁾	FC7h	SSPSTAT	FA7h	EECON2	F87h	PORTH
FE6h	POSTINC1 ⁽³⁾	FC6h	SSPCON1	FA6h	EECON1	F86h	PORTG
FE5h	POSTDEC1 ⁽³⁾	FC5h	SSPCON2	FA5h	IPR3	F85h	PORTF
FE4h	PREINC1 ⁽³⁾	FC4h	ADRESH	FA4h	PIR3	F84h	PORTE
FE3h	PLUSW1 ⁽³⁾	FC3h	ADRESL	FA3h	PIE3	F83h	PORTD
FE2h	FSR1H	FC2h	ADCON0	FA2h	IPR2	F82h	PORTC
FE1h	FSR1L	FC1h	ADCON1	FA1h	PIR2	F81h	PORTB
FE0h	BSR	FC0h	ADCON2	FA0h	PIE2	F80h	PORTA

Note 1: Unimplemented registers are read as '0'.

Note 2: This register is unused on PIC18F6X20 devices. Always maintain this register clear.

Note 3: This is not a physical register.

PIC18F6520/8520/6620/8620/6720/8720

TABLE 4-2: SPECIAL FUNCTION REGISTER MAP (CONTINUED)

Address	Name	Address	Name	Address	Name	Address	Name
F7Fh	— ⁽¹⁾	F5Fh	— ⁽¹⁾	F3Fh	— ⁽¹⁾	F1Fh	— ⁽¹⁾
F7Eh	— ⁽¹⁾	F5Eh	— ⁽¹⁾	F3Eh	— ⁽¹⁾	F1Eh	— ⁽¹⁾
F7Dh	— ⁽¹⁾	F5Dh	— ⁽¹⁾	F3Dh	— ⁽¹⁾	F1Dh	— ⁽¹⁾
F7Ch	— ⁽¹⁾	F5Ch	— ⁽¹⁾	F3Ch	— ⁽¹⁾	F1Ch	— ⁽¹⁾
F7Bh	— ⁽¹⁾	F5Bh	— ⁽¹⁾	F3Bh	— ⁽¹⁾	F1Bh	— ⁽¹⁾
F7Ah	— ⁽¹⁾	F5Ah	— ⁽¹⁾	F3Ah	— ⁽¹⁾	F1Ah	— ⁽¹⁾
F79h	— ⁽¹⁾	F59h	— ⁽¹⁾	F39h	— ⁽¹⁾	F19h	— ⁽¹⁾
F78h	TMR4	F58h	— ⁽¹⁾	F38h	— ⁽¹⁾	F18h	— ⁽¹⁾
F77h	PR4	F57h	— ⁽¹⁾	F37h	— ⁽¹⁾	F17h	— ⁽¹⁾
F76h	T4CON	F56h	— ⁽¹⁾	F36h	— ⁽¹⁾	F16h	— ⁽¹⁾
F75h	CCPR4H	F55h	— ⁽¹⁾	F35h	— ⁽¹⁾	F15h	— ⁽¹⁾
F74h	CCPR4L	F54h	— ⁽¹⁾	F34h	— ⁽¹⁾	F14h	— ⁽¹⁾
F73h	CCP4CON	F53h	— ⁽¹⁾	F33h	— ⁽¹⁾	F13h	— ⁽¹⁾
F72h	CCPR5H	F52h	— ⁽¹⁾	F32h	— ⁽¹⁾	F12h	— ⁽¹⁾
F71h	CCPR5L	F51h	— ⁽¹⁾	F31h	— ⁽¹⁾	F11h	— ⁽¹⁾
F70h	CCP5CON	F50h	— ⁽¹⁾	F30h	— ⁽¹⁾	F10h	— ⁽¹⁾
F6Fh	SPBRG2	F4Fh	— ⁽¹⁾	F2Fh	— ⁽¹⁾	F0Fh	— ⁽¹⁾
F6Eh	RCREG2	F4Eh	— ⁽¹⁾	F2Eh	— ⁽¹⁾	F0Eh	— ⁽¹⁾
F6Dh	TXREG2	F4Dh	— ⁽¹⁾	F2Dh	— ⁽¹⁾	F0Dh	— ⁽¹⁾
F6Ch	TXSTA2	F4Ch	— ⁽¹⁾	F2Ch	— ⁽¹⁾	F0Ch	— ⁽¹⁾
F6Bh	RCSTA2	F4Bh	— ⁽¹⁾	F2Bh	— ⁽¹⁾	F0Bh	— ⁽¹⁾
F6Ah	— ⁽¹⁾	F4Ah	— ⁽¹⁾	F2Ah	— ⁽¹⁾	F0Ah	— ⁽¹⁾
F69h	— ⁽¹⁾	F49h	— ⁽¹⁾	F29h	— ⁽¹⁾	F09h	— ⁽¹⁾
F68h	— ⁽¹⁾	F48h	— ⁽¹⁾	F28h	— ⁽¹⁾	F08h	— ⁽¹⁾
F67h	— ⁽¹⁾	F47h	— ⁽¹⁾	F27h	— ⁽¹⁾	F07h	— ⁽¹⁾
F66h	— ⁽¹⁾	F46h	— ⁽¹⁾	F26h	— ⁽¹⁾	F06h	— ⁽¹⁾
F65h	— ⁽¹⁾	F45h	— ⁽¹⁾	F25h	— ⁽¹⁾	F05h	— ⁽¹⁾
F64h	— ⁽¹⁾	F44h	— ⁽¹⁾	F24h	— ⁽¹⁾	F04h	— ⁽¹⁾
F63h	— ⁽¹⁾	F43h	— ⁽¹⁾	F23h	— ⁽¹⁾	F03h	— ⁽¹⁾
F62h	— ⁽¹⁾	F42h	— ⁽¹⁾	F22h	— ⁽¹⁾	F02h	— ⁽¹⁾
F61h	— ⁽¹⁾	F41h	— ⁽¹⁾	F21h	— ⁽¹⁾	F01h	— ⁽¹⁾
F60h	— ⁽¹⁾	F40h	— ⁽¹⁾	F20h	— ⁽¹⁾	F00h	— ⁽¹⁾

- Note 1:** Unimplemented registers are read as '0'.
Note 2: This register is not available on PIC18F6X20 devices.
Note 3: This is not a physical register.

PIC18F6520/8520/6620/8620/6720/8720

TABLE 4-3: REGISTER FILE SUMMARY

File Name	Bit 7	Bit 6	Bit 5	Bit 4	Bit 3	Bit 2	Bit 1	Bit 0	Value on POR, BOR	Details on page:		
TOSU	—	—	—	Top-of-Stack Upper Byte (TOS<20:16>)					---0 0000	32, 42		
TOSH	Top-of-Stack High Byte (TOS<15:8>)								0000 0000	32, 42		
TOSL	Top-of-Stack Low Byte (TOS<7:0>)								0000 0000	32, 42		
STKPTR	STKFUL	STKUNF	—	Return Stack Pointer					00-0 0000	32, 43		
PCLATU	—	—	bit 21	Holding Register for PC<20:16>							--10 0000	32, 44
PCLATH	Holding Register for PC<15:8>								0000 0000	32, 44		
PCL	PC Low Byte (PC<7:0>)								0000 0000	32, 44		
TBLPTRU	—	—	bit 21 ⁽²⁾	Program Memory Table Pointer Upper Byte (TBLPTR<20:16>)							--00 0000	32, 64
TBLPTRH	Program Memory Table Pointer High Byte (TBLPTR<15:8>)								0000 0000	32, 64		
TBLPTRL	Program Memory Table Pointer Low Byte (TBLPTR<7:0>)								0000 0000	32, 64		
TABLAT	Program Memory Table Latch								0000 0000	32, 64		
PRODH	Product Register High Byte								xxxx xxxx	32, 85		
PRODL	Product Register Low Byte								xxxx xxxx	32, 85		
INTCON	GIE/GIEH	PEIE/GIEL	TMR0IE	INT0IE	RBIE	TMR0IF	INT0IF	RBIF	0000 0000	32, 89		
INTCON2	RBPU	INTEDG0	INTEDG1	INTEDG2	INTEDG3	TMR0IP	INT3IP	RBIP	1111 1111	32, 90		
INTCON3	INT2IP	INT1IP	INT3IE	INT2IE	INT1IE	INT3IF	INT2IF	INT1IF	1100 0000	32, 91		
INDF0	Uses contents of FSR0 to address data memory – value of FSR0 not changed (not a physical register)								n/a	57		
POSTINC0	Uses contents of FSR0 to address data memory – value of FSR0 post-incremented (not a physical register)								n/a	57		
POSTDEC0	Uses contents of FSR0 to address data memory – value of FSR0 post-decremented (not a physical register)								n/a	57		
PREINC0	Uses contents of FSR0 to address data memory – value of FSR0 pre-incremented (not a physical register)								n/a	57		
PLUSW0	Uses contents of FSR0 to address data memory – value of FSR0 pre-incremented (not a physical register) – value of FSR0 offset by value in WREG								n/a	57		
FSR0H	—	—	—	—	Indirect Data Memory Address Pointer 0 High Byte				---- 0000	32, 57		
FSR0L	Indirect Data Memory Address Pointer 0 Low Byte								xxxx xxxx	32, 57		
WREG	Working Register								xxxx xxxx	32		
INDF1	Uses contents of FSR1 to address data memory – value of FSR1 not changed (not a physical register)								n/a	57		
POSTINC1	Uses contents of FSR1 to address data memory – value of FSR1 post-incremented (not a physical register)								n/a	57		
POSTDEC1	Uses contents of FSR1 to address data memory – value of FSR1 post-decremented (not a physical register)								n/a	57		
PREINC1	Uses contents of FSR1 to address data memory – value of FSR1 pre-incremented (not a physical register)								n/a	57		
PLUSW1	Uses contents of FSR1 to address data memory – value of FSR1 pre-incremented (not a physical register) – value of FSR1 offset by value in WREG								n/a	57		
FSR1H	—	—	—	—	Indirect Data Memory Address Pointer 1 High Byte				---- 0000	33, 57		
FSR1L	Indirect Data Memory Address Pointer 1 Low Byte								xxxx xxxx	33, 57		
BSR	—	—	—	—	Bank Select Register				---- 0000	33, 56		
INDF2	Uses contents of FSR2 to address data memory – value of FSR2 not changed (not a physical register)								n/a	57		
POSTINC2	Uses contents of FSR2 to address data memory – value of FSR2 post-incremented (not a physical register)								n/a	57		
POSTDEC2	Uses contents of FSR2 to address data memory – value of FSR2 post-decremented (not a physical register)								n/a	57		

Legend: x = unknown, u = unchanged, – = unimplemented, □ = value depends on condition

Note 1: RA6 and associated bits are configured as port pins in RCIO and ECIO Oscillator modes only and read '0' in all other oscillator modes.

2: Bit 21 of the TBLPTRU allows access to the device configuration bits.

3: These registers are unused on PIC18F6X20 devices; always maintain these clear.

PIC18F6520/8520/6620/8620/6720/8720

TABLE 4-3: REGISTER FILE SUMMARY (CONTINUED)

File Name	Bit 7	Bit 6	Bit 5	Bit 4	Bit 3	Bit 2	Bit 1	Bit 0	Value on POR, BOR	Details on page:
PREINC2	Uses contents of FSR2 to address data memory – value of FSR2 pre-incremented (not a physical register)								n/a	57
PLUSW2	Uses contents of FSR2 to address data memory – value of FSR2 pre-incremented (not a physical register) – value of FSR2 offset by value in WREG								n/a	57
FSR2H	—	—	—	—	Indirect Data Memory Address Pointer 2 High Byte				---- 0000	33, 57
FSR2L	Indirect Data Memory Address Pointer 2 Low Byte								xxxx xxxx	33, 57
STATUS	—	—	—	N	OV	Z	DC	C	--x xxxx	33, 59
TMR0H	Timer0 Register High Byte								0000 0000	33, 133
TMR0L	Timer0 Register Low Byte								xxxx xxxx	33, 133
T0CON	TMR0ON	T08BIT	T0CS	T0SE	PSA	T0PS2	T0PS1	T0PS0	1111 1111	33, 131
OSCCON	—	—	—	—	—	—	—	SCS	---- --0	25, 33
LVDCON	—	—	IRVST	LVDEN	LVDL3	LVDL2	LVDL1	LVDL0	--00 0101	33, 235
WDTCON	—	—	—	—	—	—	—	SWDTE	---- --0	33, 250
RCON	IPEN	—	—	RI	TO	PD	POR	BOR	0--1 11qq	33, 60, 101
TMR1H	Timer1 Register High Byte								xxxx xxxx	33, 135
TMR1L	Timer1 Register Low Byte								xxxx xxxx	33, 135
T1CON	RD16	—	T1CKPS1	T1CKPS0	T1OSCEN	T1SYN \bar{C}	TMR1CS	TMR1ON	0-00 0000	33, 135
TMR2	Timer2 Register								0000 0000	33, 141
PR2	Timer2 Period Register								1111 1111	33, 142
T2CON	—	T2OUTPS3	T2OUTPS2	T2OUTPS1	T2OUTPS0	TMR2ON	T2CKPS1	T2CKPS0	-000 0000	33, 141
SSPBUF	SSP Receive Buffer/Transmit Register								xxxx xxxx	33, 157
SSPADD	SSP Address Register in I ² C Slave mode. SSP Baud Rate Reload Register in I ² C Master mode.								0000 0000	33, 166
SSPSTAT	SMP	CKE	D/A	P	S	R/W	UA	BF	0000 0000	33, 158
SSPCON1	WCOL	SSPOV	SSPEN	CKP	SSPM3	SSPM2	SSPM1	SSPM0	0000 0000	33, 168
SSPCON2	GCEN	ACKSTAT	ACKDT	ACKEN	RCEN	PEN	RSEN	SEN	0000 0000	33, 169
ADRESH	A/D Result Register High Byte								xxxx xxxx	34, 215
ADRESL	A/D Result Register Low Byte								xxxx xxxx	34, 215
ADCON0	—	—	CHS3	CHS2	CHS1	CHS0	GO/DONE	ADON	--00 0000	34, 213
ADCON1	—	—	VCFG1	VCFG0	PCFG3	PCFG2	PCFG1	PCFG0	--00 0000	34, 214
ADCON2	ADFM	—	—	—	—	ADCS2	ADCS1	ADCS0	0--- -000	34, 215
CCPR1H	Capture/Compare/PWM Register 1 High Byte								xxxx xxxx	34, 151, 152
CCPR1L	Capture/Compare/PWM Register 1 Low Byte								xxxx xxxx	34, 151, 152
CCP1CON	—	—	DC1B1	DC1B0	CCP1M3	CCP1M2	CCP1M1	CCP1M0	--00 0000	34, 149
CCPR2H	Capture/Compare/PWM Register 2 High Byte								xxxx xxxx	34, 151, 152
CCPR2L	Capture/Compare/PWM Register 2 Low Byte								xxxx xxxx	34, 151, 152
CCP2CON	—	—	DC2B1	DC2B0	CCP2M3	CCP2M2	CCP2M1	CCP2M0	--00 0000	34, 149

Legend: x = unknown, u = unchanged, — = unimplemented, q = value depends on condition

Note 1: RA6 and associated bits are configured as port pins in RCIO and ECIO Oscillator modes only and read '0' in all other oscillator modes.

2: Bit 21 of the TBLPTRU allows access to the device configuration bits.

3: These registers are unused on PIC18F6X20 devices; always maintain these clear.

PIC18F6520/8520/6620/8620/6720/8720

TABLE 4-3: REGISTER FILE SUMMARY (CONTINUED)

File Name	Bit 7	Bit 6	Bit 5	Bit 4	Bit 3	Bit 2	Bit 1	Bit 0	Value on POR, BOR	Details on page:
CCPR3H	Capture/Compare/PWM Register 3 High Byte								xxxx xxxx	34, 151, 152
CCPR3L	Capture/Compare/PWM Register 3 Low Byte								xxxx xxxx	34, 151, 152
CCP3CON	—	—	DC3B1	DC3B0	CCP3M3	CCP3M2	CCP3M1	CCP3M0	--00 0000	34, 149
CVRCON	CVREN	CVROE	CVRR	CVRSS	CVR3	CVR2	CVR1	CVR0	0000 0000	34, 229
CMCON	C2OUT	C1OUT	C2INV	C1INV	CIS	CM2	CM1	CM0	0000 0000	34, 223
TMR3H	Timer3 Register High Byte								xxxx xxxx	34, 143
TMR3L	Timer3 Register Low Byte								xxxx xxxx	34, 143
T3CON	RD16	T3CCP2	T3CKPS1	T3CKPS0	T3CCP1	T3SYN \bar{C}	TMR3CS	TMR3ON	0000 0000	34, 143
PSPCON	IBF	OBF	IBOV	PSPMODE	—	—	—	—	0000 ----	34, 129
SPBRG1	USART1 Baud Rate Generator								0000 0000	34, 205
RCREG1	USART1 Receive Register								0000 0000	34, 206
TXREG1	USART1 Transmit Register								0000 0000	34, 204
TXSTA1	CSRC	TX9	TXEN	SYNC	—	BRGH	TRMT	TX9D	0000 -010	34, 198
RCSTA1	SPEN	RX9	SREN	CREN	ADDEN	FERR	OERR	RX9D	0000 000x	34, 199
EEADRH	—	—	—	—	—	—	EE Adr Register High		---- --00	34, 79
EEADR	Data EEPROM Address Register								0000 0000	34, 79
EEDATA	Data EEPROM Data Register								0000 0000	34, 79
EECON2	Data EEPROM Control Register 2 (not a physical register)								---- ----	34, 79
EECON1	EEPGD	CFGS	—	FREE	WRERR	WREN	WR	RD	xx-0 x000	34, 80
IPR3	—	—	RC2IP	TX2IP	TMR4IP	CCP5IP	CCP4IP	CCP3IP	--11 1111	35, 100
PIR3	—	—	RC2IF	TX2IF	TMR4IF	CCP5IF	CCP4IF	CCP3IF	--00 0000	35, 94
PIE3	—	—	RC2IE	TX2IE	TMR4IE	CCP5IE	CCP4IE	CCP3IE	--00 0000	35, 97
IPR2	—	CMIP	—	EEIP	BCLIP	LVDIP	TMR3IP	CCP2IP	-1-1 1111	35, 99
PIR2	—	CMIF	—	EEIF	BCLIF	LVDIF	TMR3IF	CCP2IF	-0-0 0000	35, 93
PIE2	—	CMIE	—	EEIE	BCLIE	LVDIE	TMR3IE	CCP2IE	-0-0 0000	35, 96
IPR1	PSPIP	ADIP	RCIP	TXIP	SSPIP	CCP1IP	TMR2IP	TMR1IP	0111 1111	35, 98
PIR1	PSPIF	ADIF	RCIF	TXIF	SSPIF	CCP1IF	TMR2IF	TMR1IF	0000 0000	35, 92
PIE1	PSPIE	ADIE	RCIE	TXIE	SSPIE	CCP1IE	TMR2IE	TMR1IE	0000 0000	35, 95
MEMCON ⁽³⁾	EBDIS	—	WAIT1	WAIT0	—	—	WM1	WM0	0-00 --00	35, 71
TRISJ ⁽³⁾	Data Direction Control Register for PORTJ								1111 1111	35, 125
TRISH ⁽³⁾	Data Direction Control Register for PORTH								1111 1111	35, 122
TRISG	—	—	—	Data Direction Control Register for PORTG				---	1111	35, 120
TRISF	Data Direction Control Register for PORTF								1111 1111	35, 117
TRISE	Data Direction Control Register for PORTE								1111 1111	35, 114
TRISD	Data Direction Control Register for PORTD								1111 1111	35, 111
TRISC	Data Direction Control Register for PORTC								1111 1111	35, 109
TRISB	Data Direction Control Register for PORTB								1111 1111	35, 106
TRISA	—	TRISA6 ⁽¹⁾	Data Direction Control Register for PORTA					-111	1111	35, 103

Legend: x = unknown, u = unchanged, — = unimplemented, \bar{c} = value depends on condition

Note 1: RA6 and associated bits are configured as port pins in RCIO and ECIO Oscillator modes only and read '0' in all other oscillator modes.

2: Bit 21 of the TBLPTRU allows access to the device configuration bits.

3: These registers are unused on PIC18F6X20 devices; always maintain these clear.

PIC18F6520/8520/6620/8620/6720/8720

TABLE 4-3: REGISTER FILE SUMMARY (CONTINUED)

File Name	Bit 7	Bit 6	Bit 5	Bit 4	Bit 3	Bit 2	Bit 1	Bit 0	Value on POR, BOR	Details on page:
LATJ ⁽³⁾	Read PORTJ Data Latch, Write PORTJ Data Latch								xxxx xxxx	35, 125
LATH ⁽³⁾	Read PORTH Data Latch, Write PORTH Data Latch								xxxx xxxx	35, 122
LATG	—	—	—	Read PORTG Data Latch, Write PORTG Data Latch				---x xxxx	35, 120	
LATF	Read PORTF Data Latch, Write PORTF Data Latch								xxxx xxxx	35, 117
LATE	Read PORTE Data Latch, Write PORTE Data Latch								xxxx xxxx	35, 114
LATD	Read PORTD Data Latch, Write PORTD Data Latch								xxxx xxxx	35, 111
LATC	Read PORTC Data Latch, Write PORTC Data Latch								xxxx xxxx	35, 109
LATB	Read PORTB Data Latch, Write PORTB Data Latch								xxxx xxxx	35, 106
LATA	—	LATA6 ⁽¹⁾	Read PORTA Data Latch, Write PORTA Data Latch ⁽¹⁾						-xxx xxxx	35, 103
PORTJ ⁽³⁾	Read PORTJ pins, Write PORTJ Data Latch								xxxx xxxx	36, 125
PORTH ⁽³⁾	Read PORTH pins, Write PORTH Data Latch								xxxx xxxx	36, 122
PORTG	—	—	—	Read PORTG pins, Write PORTG Data Latch				---x xxxx	36, 120	
PORTF	Read PORTF pins, Write PORTF Data Latch								xxxx xxxx	36, 117
PORTE	Read PORTE pins, Write PORTE Data Latch								xxxx xxxx	36, 114
PORTD	Read PORTD pins, Write PORTD Data Latch								xxxx xxxx	36, 111
PORTC	Read PORTC pins, Write PORTC Data Latch								xxxx xxxx	36, 109
PORTB	Read PORTB pins, Write PORTB Data Latch								xxxx xxxx	36, 106
PORTA	—	RA6 ⁽¹⁾	Read PORTA pins, Write PORTA Data Latch ⁽¹⁾						-x0x 0000	36, 103
TMR4	Timer4 Register								0000 0000	36, 148
PR4	Timer4 Period Register								1111 1111	36, 148
T4CON	—	T4OUTPS3	T4OUTPS2	T4OUTPS1	T4OUTPS0	TMR4ON	T4CKPS1	T4CKPS0	-000 0000	36, 147
CCPR4H	Capture/Compare/PWM Register 4 High Byte								xxxx xxxx	36, 151, 152
CCPR4L	Capture/Compare/PWM Register 4 Low Byte								xxxx xxxx	36, 151, 152
CCP4CON	—	—	DC4B1	DC4B0	CCP4M3	CCP4M2	CCP4M1	CCP4M0	0000 0000	36, 149
CCPR5H	Capture/Compare/PWM Register 5 High Byte								xxxx xxxx	36, 151, 152
CCPR5L	Capture/Compare/PWM Register 5 Low Byte								xxxx xxxx	36, 151, 152
CCP5CON	—	—	DC5B1	DC5B0	CCP5M3	CCP5M2	CCP5M1	CCP5M0	0000 0000	36, 149
SPBRG2	USART2 Baud Rate Generator								0000 0000	36, 205
RCREG2	USART2 Receive Register								0000 0000	36, 206
TXREG2	USART2 Transmit Register								0000 0000	36, 204
TXSTA2	CSRC	TX9	TXEN	SYNC	—	BRGH	TRMT	TX9D	0000 -010	36, 198
RCSTA2	SPEN	RX9	SREN	CREN	ADDEN	FERR	OERR	RX9D	0000 000x	36, 199

Legend: x = unknown, u = unchanged, — = unimplemented, q = value depends on condition

Note 1: RA6 and associated bits are configured as port pins in RCIO and ECIO Oscillator modes only and read '0' in all other oscillator modes.

2: Bit 21 of the TBLPTRU allows access to the device configuration bits.

3: These registers are unused on PIC18F6X20 devices; always maintain these clear.

PIC18F6520/8520/6620/8620/6720/8720

4.10 Access Bank

The Access Bank is an architectural enhancement, which is very useful for C compiler code optimization. The techniques used by the C compiler may also be useful for programs written in assembly.

This data memory region can be used for:

- Intermediate computational values
- Local variables of subroutines
- Faster context saving/switching of variables
- Common variables
- Faster evaluation/control of SFRs (no banking)

The Access Bank is comprised of the upper 160 bytes in Bank 15 (SFRs) and the lower 96 bytes in Bank 0. These two sections will be referred to as Access RAM High and Access RAM Low, respectively. Figure 4-7 indicates the Access RAM areas.

A bit in the instruction word specifies if the operation is to occur in the bank specified by the BSR register or in the Access Bank. This bit is denoted by the 'a' bit (for access bit).

When forced in the Access Bank ($a = 0$), the last address in Access RAM Low is followed by the first address in Access RAM High. Access RAM High maps the Special Function Registers, so that these registers can be accessed without any software overhead. This is useful for testing status flags and modifying control bits.

4.11 Bank Select Register (BSR)

The need for a large general purpose memory space dictates a RAM banking scheme. The data memory is partitioned into sixteen banks. When using direct addressing, the BSR should be configured for the desired bank.

BSR<3:0> holds the upper 4 bits of the 12-bit RAM address. The BSR<7:4> bits will always read '0's and writes will have no effect.

A `MOVLB` instruction has been provided in the instruction set to assist in selecting banks.

If the currently selected bank is not implemented, any read will return all '0's and all writes are ignored. The Status register bits will be set/cleared as appropriate for the instruction performed.

Each Bank extends up to FFh (256 bytes). All data memory is implemented as static RAM.

A `MOVFF` instruction ignores the BSR, since the 12-bit addresses are embedded into the instruction word.

Section 4.12 "Indirect Addressing, INDF and FSR Registers" provides a description of indirect addressing, which allows linear addressing of the entire RAM space.

FIGURE 4-8: DIRECT ADDRESSING

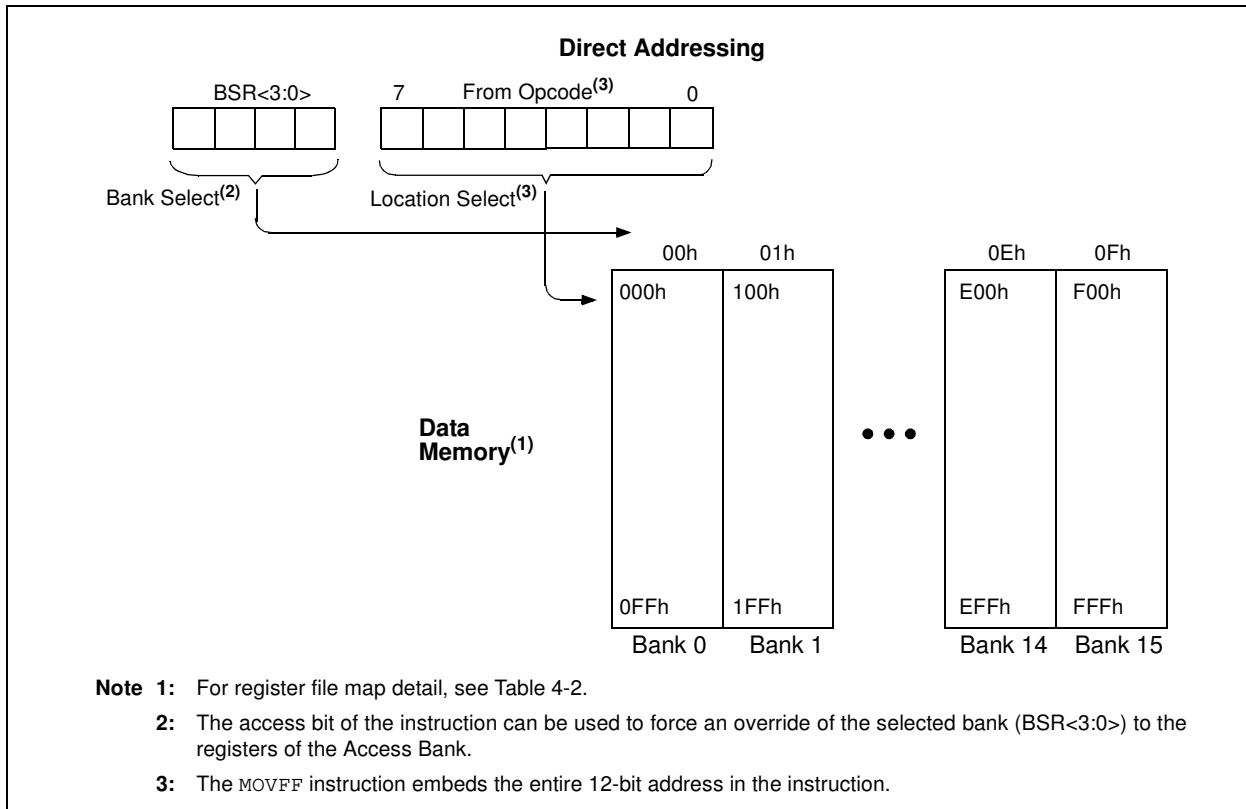

4.12 Indirect Addressing, INDF and FSR Registers

Indirect addressing is a mode of addressing data memory, where the data memory address in the instruction is not fixed. An FSR register is used as a pointer to the data memory location that is to be read or written. Since this pointer is in RAM, the contents can be modified by the program. This can be useful for data tables in the data memory and for software stacks. Figure 4-9 shows the operation of indirect addressing. This shows the moving of the value to the data memory address, specified by the value of the FSR register.

Indirect addressing is possible by using one of the INDF registers. Any instruction using the INDF register actually accesses the register pointed to by the File Select Register, FSR. Reading the INDF register itself, indirectly (FSR = 0), will read 00h. Writing to the INDF register indirectly, results in a no operation. The FSR register contains a 12-bit address, which is shown in Figure 4-10.

The INDFn register is not a physical register. Addressing INDFn actually addresses the register whose address is contained in the FSRn register (FSRn is a pointer). This is indirect addressing.

Example 4-4 shows a simple use of indirect addressing to clear the RAM in Bank 1 (locations 100h-1FFh) in a minimum number of instructions.

EXAMPLE 4-4: HOW TO CLEAR RAM (BANK 1) USING INDIRECT ADDRESSING

```

        LFSR   FSR0, 0x100 ;
NEXT    CLRf   POSTINC0    ; Clear INDF
        ; register and
        ; inc pointer
        BTFSS FSR0H, 1    ; All done with
        ; Bank 1?
        GOTO  NEXT        ; NO, clear next
CONTINUE ; YES, continue
    
```

There are three indirect addressing registers. To address the entire data memory space (4096 bytes), these registers are 12 bits wide. To store the 12 bits of addressing information, two 8-bit registers are required. These indirect addressing registers are:

1. FSR0: composed of FSR0H:FSR0L
2. FSR1: composed of FSR1H:FSR1L
3. FSR2: composed of FSR2H:FSR2L

In addition, there are registers INDF0, INDF1 and INDF2, which are not physically implemented. Reading or writing to these registers activates indirect addressing, with the value in the corresponding FSR register being the address of the data. If an instruction writes a value to INDF0, the value will be written to the address pointed to by FSR0H:FSR0L. A read from INDF1 reads

the data from the address pointed to by FSR1H:FSR1L. INDFn can be used in code anywhere an operand can be used.

If INDF0, INDF1 or INDF2 are read indirectly via an FSR, all '0's are read (zero bit is set). Similarly, if INDF0, INDF1 or INDF2 are written to indirectly, the operation will be equivalent to a NOP instruction and the Status bits are not affected.

4.12.1 INDIRECT ADDRESSING OPERATION

Each FSR register has an INDF register associated with it, plus four additional register addresses. Performing an operation on one of these five registers determines how the FSR will be modified during indirect addressing.

When data access is done to one of the five INDFn locations, the address selected will configure the FSRn register to:

- Do nothing to FSRn after an indirect access (no change) – INDFn.
- Auto-decrement FSRn after an indirect access (post-decrement) – POSTDECn.
- Auto-increment FSRn after an indirect access (post-increment) – POSTINCn.
- Auto-increment FSRn before an indirect access (pre-increment) – PREINCn.
- Use the value in the WREG register as an offset to FSRn. Do not modify the value of the WREG or the FSRn register after an indirect access (no change) – PLUSWn.

When using the auto-increment or auto-decrement features, the effect on the FSR is not reflected in the Status register. For example, if the indirect address causes the FSR to equal '0', the Z bit will not be set.

Incrementing or decrementing an FSR affects all 12 bits. That is, when FSRnL overflows from an increment, FSRnH will be incremented automatically.

Adding these features allows the FSRn to be used as a stack pointer, in addition to its uses for table operations in data memory.

Each FSR has an address associated with it that performs an indexed indirect access. When a data access to this INDFn location (PLUSWn) occurs, the FSRn is configured to add the signed value in the WREG register and the value in FSR to form the address before an indirect access. The FSR value is not changed.

If an FSR register contains a value that points to one of the INDFn, an indirect read will read 00h (zero bit is set), while an indirect write will be equivalent to a NOP (Status bits are not affected).

If an indirect addressing operation is done where the target address is an FSRnH or FSRnL register, the write operation will dominate over the pre- or post-increment/decrement functions.

PIC18F6520/8520/6620/8620/6720/8720

FIGURE 4-9: INDIRECT ADDRESSING OPERATION

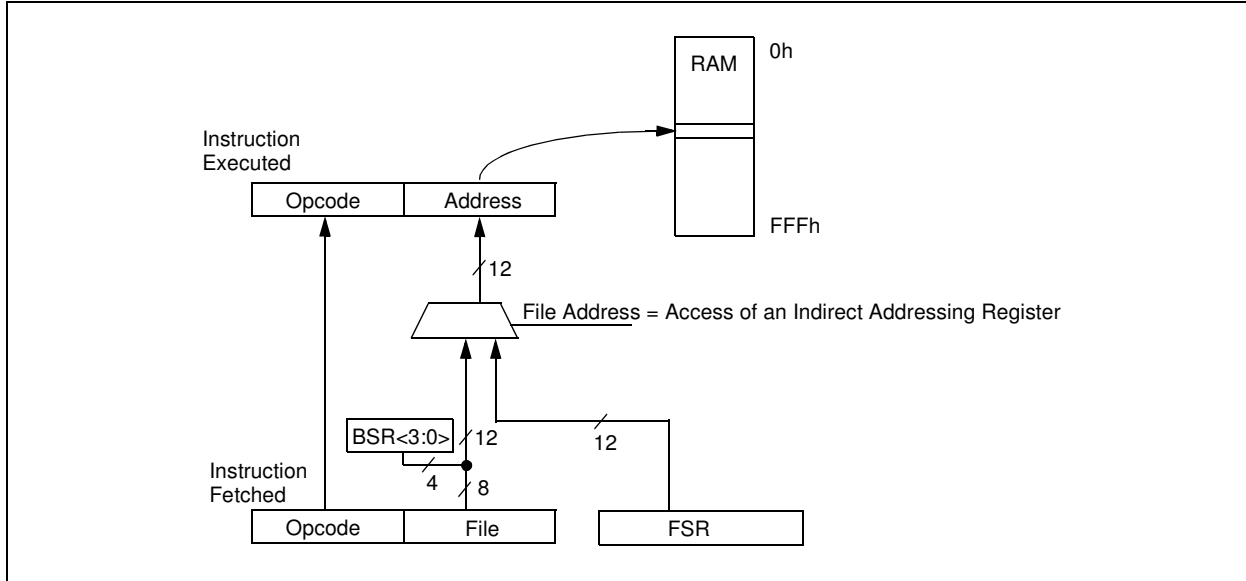
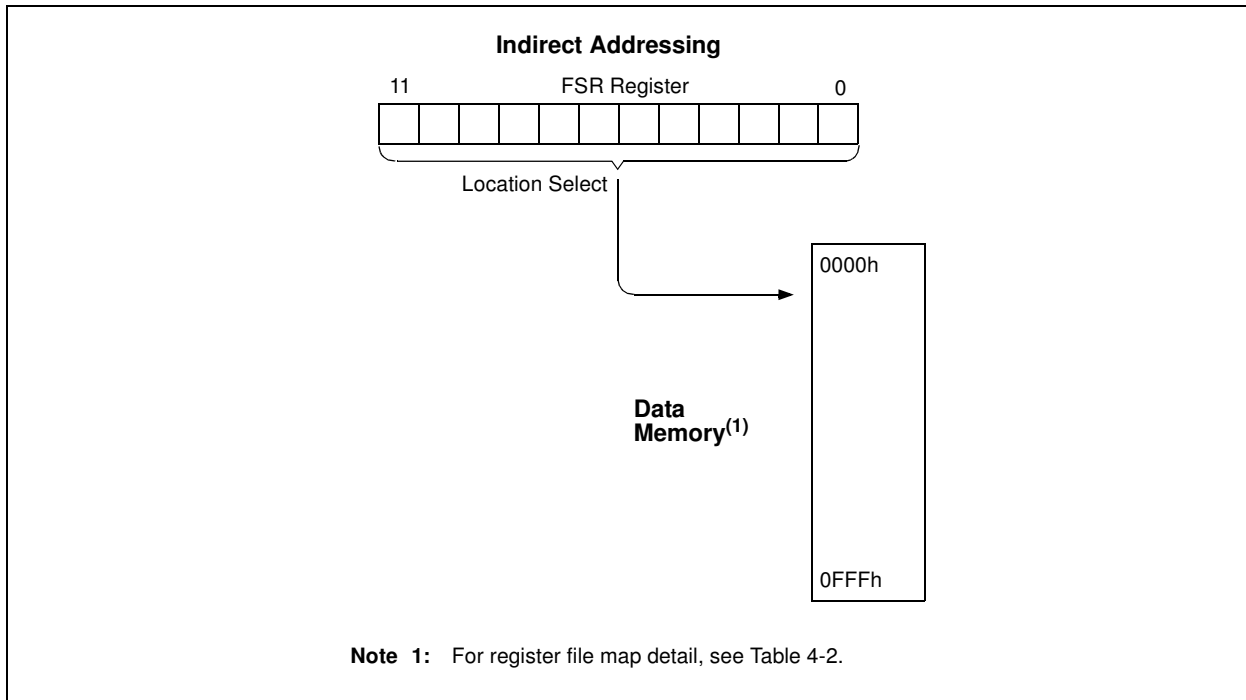

FIGURE 4-10: INDIRECT ADDRESSING



PIC18F6520/8520/6620/8620/6720/8720

4.13 Status Register

The Status register, shown in Register 4-3, contains the arithmetic status of the ALU. The Status register can be the destination for any instruction, as with any other register. If the Status register is the destination for an instruction that affects the Z, DC, C, OV or N bits, then the write to these five bits is disabled. These bits are set or cleared according to the device logic. Therefore, the result of an instruction with the Status register as destination may be different than intended.

For example, `CLRF STATUS` will clear the upper three bits and set the Z bit. This leaves the Status register as `000u u1uu` (where u = unchanged).

It is recommended, therefore, that only `BCF`, `BSF`, `SWAPF`, `MOVFF` and `MOVWF` instructions are used to alter the Status register, because these instructions do not affect the Z, C, DC, OV or N bits from the Status register. For other instructions not affecting any status bits, see Table 24-1.

Note: The C and DC bits operate as a borrow and digit borrow bit respectively, in subtraction.

REGISTER 4-3: STATUS REGISTER

U-0	U-0	U-0	R/W-x	R/W-x	R/W-x	R/W-x	R/W-x	
—	—	—	N	OV	Z	DC	C	
bit 7								bit 0

bit 7-5 **Unimplemented:** Read as '0'

bit 4 **N:** Negative bit

This bit is used for signed arithmetic (2's complement). It indicates whether the result was negative (ALU MSB = 1).

- 1 = Result was negative
- 0 = Result was positive

bit 3 **OV:** Overflow bit

This bit is used for signed arithmetic (2's complement). It indicates an overflow of the 7-bit magnitude, which causes the sign bit (bit 7) to change state.

- 1 = Overflow occurred for signed arithmetic (in this arithmetic operation)
- 0 = No overflow occurred

bit 2 **Z:** Zero bit

- 1 = The result of an arithmetic or logic operation is zero
- 0 = The result of an arithmetic or logic operation is not zero

bit 1 **DC:** Digit carry/borrow bit

For `ADDWF`, `ADDLW`, `SUBLW` and `SUBWF` instructions:

- 1 = A carry-out from the 4th low-order bit of the result occurred
- 0 = No carry-out from the 4th low-order bit of the result

Note: For borrow, the polarity is reversed. A subtraction is executed by adding the 2's complement of the second operand. For rotate (`RRF`, `RLF`) instructions, this bit is loaded with either bit 4 or bit 3 of the source register.

bit 0 **C:** Carry/borrow bit

For `ADDWF`, `ADDLW`, `SUBLW` and `SUBWF` instructions:

- 1 = A carry-out from the Most Significant bit of the result occurred
- 0 = No carry-out from the Most Significant bit of the result occurred

Note: For borrow, the polarity is reversed. A subtraction is executed by adding the 2's complement of the second operand. For rotate (`RRF`, `RLF`) instructions, this bit is loaded with either the high or low-order bit of the source register.

Legend:

R = Readable bit	W = Writable bit	U = Unimplemented bit, read as '0'
- n = Value at POR	'1' = Bit is set	'0' = Bit is cleared x = Bit is unknown

PIC18F6520/8520/6620/8620/6720/8720

4.14 RCON Register

The Reset Control (RCON) register contains flag bits that allow differentiation between the sources of a device Reset. These flags include the $\overline{\text{TO}}$, $\overline{\text{PD}}$, $\overline{\text{POR}}$, $\overline{\text{BOR}}$ and $\overline{\text{RI}}$ bits. This register is readable and writable.

Note 1: If the BOREN configuration bit is set (Brown-out Reset enabled), the $\overline{\text{BOR}}$ bit is '1' on a Power-on Reset. After a Brown-out Reset has occurred, the BOR bit will be cleared and must be set by firmware to indicate the occurrence of the next Brown-out Reset.

2: It is recommended that the $\overline{\text{POR}}$ bit be set after a Power-on Reset has been detected, so that subsequent Power-on Resets may be detected.

REGISTER 4-4: RCON REGISTER

R/W-0	U-0	U-0	R/W-1	R/W-1	R/W-1	R/W-0	R/W-0
IPEN	—	—	$\overline{\text{RI}}$	$\overline{\text{TO}}$	$\overline{\text{PD}}$	$\overline{\text{POR}}$	$\overline{\text{BOR}}$
bit 7							bit 0

- bit 7 **IPEN:** Interrupt Priority Enable bit
 1 = Enable priority levels on interrupts
 0 = Disable priority levels on interrupts (PIC16CXXX Compatibility mode)
- bit 6-5 **Unimplemented:** Read as '0'
- bit 4 **RI:** RESET Instruction Flag bit
 1 = The RESET instruction was not executed
 0 = The RESET instruction was executed causing a device Reset (must be set in software after a Brown-out Reset occurs)
- bit 3 **TO:** Watchdog Time-out Flag bit
 1 = After power-up, CLRWDT instruction, or SLEEP instruction
 0 = A WDT time-out occurred
- bit 2 **PD:** Power-down Detection Flag bit
 1 = After power-up or by the CLRWDT instruction
 0 = By execution of the SLEEP instruction
- bit 1 **POR:** Power-on Reset Status bit
 1 = A Power-on Reset has not occurred
 0 = A Power-on Reset occurred (must be set in software after a Power-on Reset occurs)
- bit 0 **BOR:** Brown-out Reset Status bit
 1 = A Brown-out Reset has not occurred
 0 = A Brown-out Reset occurred (must be set in software after a Brown-out Reset occurs)

Legend:

R = Readable bit W = Writable bit U = Unimplemented bit, read as '0'
 - n = Value at POR '1' = Bit is set '0' = Bit is cleared x = Bit is unknown

5.0 FLASH PROGRAM MEMORY

The Flash program memory is readable, writable and erasable, during normal operation over the entire VDD range.

A read from program memory is executed on one byte at a time. A write to program memory is executed on blocks of 8 bytes at a time. Program memory is erased in blocks of 64 bytes at a time. A bulk erase operation may not be issued from user code.

Writing or erasing program memory will cease instruction fetches until the operation is complete. The program memory cannot be accessed during the write or erase, therefore, code cannot execute. An internal programming timer terminates program memory writes and erases.

A value written to program memory does not need to be a valid instruction. Executing a program memory location that forms an invalid instruction results in a NOP.

5.1 Table Reads and Table Writes

In order to read and write program memory, there are two operations that allow the processor to move bytes between the program memory space and the data RAM:

- Table Read (TBLRD)
- Table Write (TBLWT)

The program memory space is 16 bits wide, while the data RAM space is 8 bits wide. Table reads and table writes move data between these two memory spaces through an 8-bit register (TABLAT).

Table read operations retrieve data from program memory and place it into the data RAM space. Figure 5-1 shows the operation of a table read with program memory and data RAM.

Table write operations store data from the data memory space into holding registers in program memory. The procedure to write the contents of the holding registers into program memory is detailed in **Section 5.5 “Writing to Flash Program Memory”**. Figure 5-2 shows the operation of a table write with program memory and data RAM.

Table operations work with byte entities. A table block containing data, rather than program instructions, is not required to be word aligned. Therefore, a table block can start and end at any byte address. If a table write is being used to write executable code into program memory, program instructions will need to be word aligned.

FIGURE 5-1: TABLE READ OPERATION

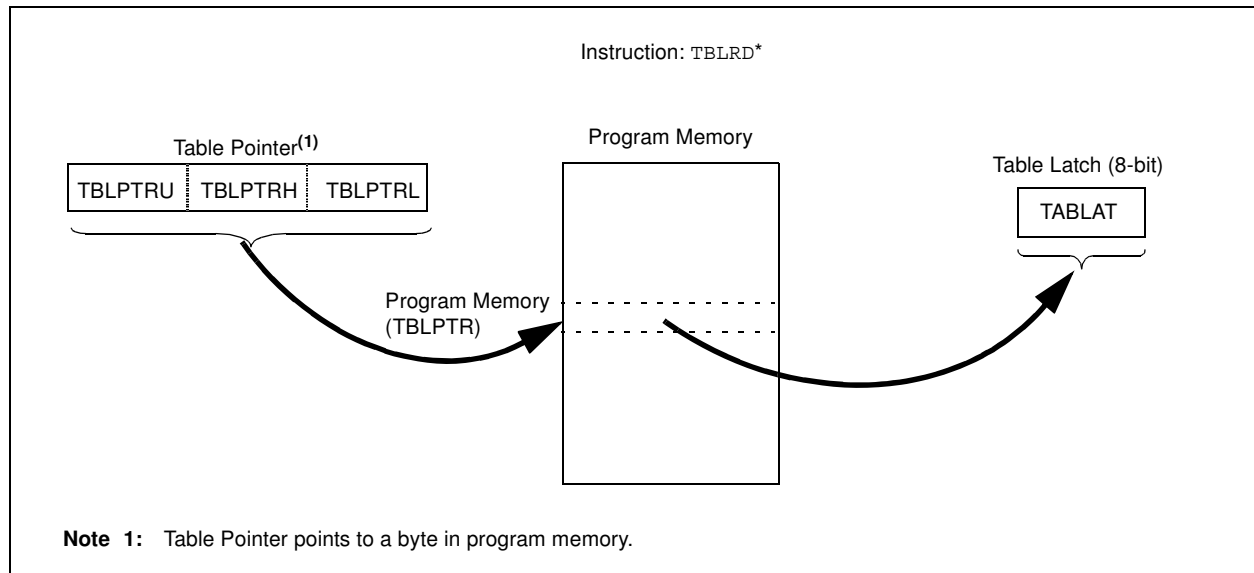

PIC18F6520/8520/6620/8620/6720/8720

FIGURE 5-2: TABLE WRITE OPERATION

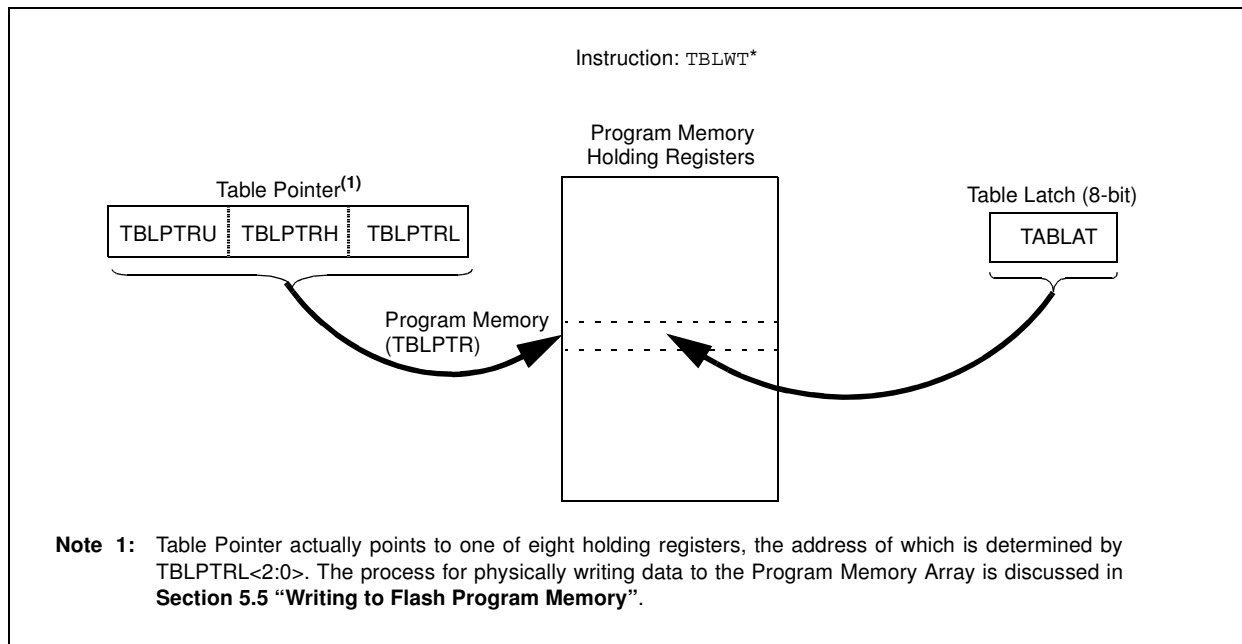

5.2 Control Registers

Several control registers are used in conjunction with the TBLRD and TBLWT instructions. These include the:

- EECON1 register
- EECON2 register
- TABLAT register
- TBLPTR registers

5.2.1 EECON1 AND EECON2 REGISTERS

EECON1 is the control register for memory accesses.

EECON2 is not a physical register. Reading EECON2 will read all '0's. The EECON2 register is used exclusively in the memory write and erase sequences.

Control bit EEPGD determines if the access will be a program or data EEPROM memory access. When clear, any subsequent operations will operate on the data EEPROM memory. When set, any subsequent operations will operate on the program memory.

Control bit CFGS determines if the access will be to the configuration/calibration registers, or to program memory/data EEPROM memory. When set, subsequent operations will operate on configuration registers, regardless of EEPGD (see Section 23.0 “Special Features of the CPU”). When clear, memory selection access is determined by EEPGD.

The FREE bit, when set, will allow a program memory erase operation. When the FREE bit is set, the erase operation is initiated on the next WR command. When FREE is clear, only writes are enabled.

The WREN bit, when set, will allow a write operation. On power-up, the WREN bit is clear. The WRERR bit is set when a write operation is interrupted by a MCLR Reset, or a WDT Time-out Reset during normal operation. In these situations, the user can check the WRERR bit and rewrite the location. It is necessary to reload the data and address registers (EEDATA and EEADR), due to Reset values of zero.

The WR control bit, initiates write operations. The bit cannot be cleared, only set, in software; it is cleared in hardware at the completion of the write operation. The inability to clear the WR bit in software prevents the accidental or premature termination of a write operation.

Note: Interrupt flag bit, EEIF in the PIR2 register, is set when the write is complete. It must be cleared in software.

PIC18F6520/8520/6620/8620/6720/8720

REGISTER 5-1: EECON1 REGISTER (ADDRESS FA6h)

R/W-x	R/W-x	U-0	R/W-0	R/W-x	R/W-0	R/S-0	R/S-0
EEPGD	CFGS	—	FREE	WRERR	WREN	WR	RD
bit 7						bit 0	

- bit 7 **EEPGD:** Flash Program or Data EEPROM Memory Select bit
 1 = Access Flash program memory
 0 = Access data EEPROM memory
- bit 6 **CFGS:** Flash Program/Data EEPROM or Configuration Select bit
 1 = Access configuration registers
 0 = Access Flash program or data EEPROM memory
- bit 5 **Unimplemented:** Read as '0'
- bit 4 **FREE:** Flash Row Erase Enable bit
 1 = Erase the program memory row addressed by TBLPTR on the next WR command (cleared by completion of erase operation)
 0 = Perform write only
- bit 3 **WRERR:** Flash Program/Data EEPROM Error Flag bit
 1 = A write operation is prematurely terminated (any Reset during self-timed programming in normal operation)
 0 = The write operation completed
- Note:** When a WRERR occurs, the EEPGD and CFGS bits are not cleared. This allows tracing of the error condition.
- bit 2 **WREN:** Flash Program/Data EEPROM Write Enable bit
 1 = Allows write cycles to Flash program/data EEPROM
 0 = Inhibits write cycles to Flash program/data EEPROM
- bit 1 **WR:** Write Control bit
 1 = Initiates a data EEPROM erase/write cycle or a program memory erase cycle or write cycle. (The operation is self-timed and the bit is cleared by hardware once write is complete. The WR bit can only be set (not cleared) in software.)
 0 = Write cycle to the EEPROM is complete
- bit 0 **RD:** Read Control bit
 1 = Initiates an EEPROM read (Read takes one cycle. RD is cleared in hardware. The RD bit can only be set (not cleared) in software. RD bit cannot be set when EEPGD = 1.)
 0 = Does not initiate an EEPROM read

Legend:

R = Readable bit	W = Writable bit	U = Unimplemented bit, read as '0'
- n = Value at POR	'1' = Bit is set	'0' = Bit is cleared x = Bit is unknown

PIC18F6520/8520/6620/8620/6720/8720

5.2.2 TABLAT – TABLE LATCH REGISTER

The Table Latch (TABLAT) is an 8-bit register mapped into the SFR space. The Table Latch is used to hold 8-bit data during data transfers between program memory and data RAM.

5.2.3 TBLPTR – TABLE POINTER REGISTER

The Table Pointer (TBLPTR) addresses a byte within the program memory. The TBLPTR is comprised of three SFR registers: Table Pointer Upper Byte, Table Pointer High Byte and Table Pointer Low Byte (TBLPTRU:TBLPTRH:TBLPTRL). These three registers join to form a 22-bit wide pointer. The low-order 21 bits allow the device to address up to 2 Mbytes of program memory space. The 22nd bit allows access to the Device ID, the User ID and the configuration bits.

The Table Pointer, TBLPTR, is used by the TBLRD and TBLWT instructions. These instructions can update the TBLPTR in one of four ways, based on the table operation. These operations are shown in Table 5-1. These operations on the TBLPTR only affect the low-order 21 bits.

5.2.4 TABLE POINTER BOUNDARIES

TBLPTR is used in reads, writes and erases of the Flash program memory.

When a TBLRD is executed, all 22 bits of the Table Pointer determine which byte is read from program memory into TABLAT.

When a TBLWT is executed, the three LSbs of the Table Pointer (TBLPTR<2:0>) determine which of the eight program memory holding registers is written to. When the timed write to program memory (long write) begins, the 19 MSBs of the Table Pointer, TBLPTR (TBLPTR<21:3>), will determine which program memory block of 8 bytes is written to. For more detail, see **Section 5.5 “Writing to Flash Program Memory”**.

When an erase of program memory is executed, the 16 MSBs of the Table Pointer (TBLPTR<21:6>) point to the 64-byte block that will be erased. The Least Significant bits (TBLPTR<5:0>) are ignored.

Figure 5-3 describes the relevant boundaries of TBLPTR based on Flash program memory operations.

TABLE 5-1: TABLE POINTER OPERATIONS WITH TBLRD AND TBLWT INSTRUCTIONS

Example	Operation on Table Pointer
TBLRD* TBLWT*	TBLPTR is not modified
TBLRD** TBLWT**	TBLPTR is incremented after the read/write
TBLRD*- TBLWT*-	TBLPTR is decremented after the read/write
TBLRD+* TBLWT+*	TBLPTR is incremented before the read/write

FIGURE 5-3: TABLE POINTER BOUNDARIES BASED ON OPERATION

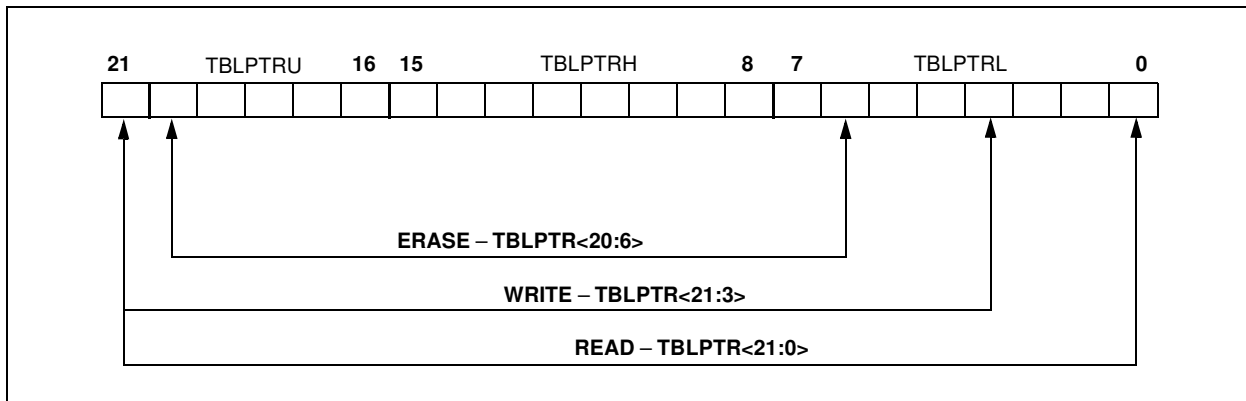

PIC18F6520/8520/6620/8620/6720/8720

5.3 Reading the Flash Program Memory

The `TBLRD` instruction is used to retrieve data from program memory and places it into data RAM. Table reads from program memory are performed one byte at a time.

`TBLPTR` points to a byte address in program space. Executing `TBLRD` places the byte pointed to into `TABLAT`. In addition, `TBLPTR` can be modified automatically for the next table read operation.

The internal program memory is typically organized by words. The Least Significant bit of the address selects between the high and low bytes of the word. Figure 5-4 shows the interface between the internal program memory and the `TABLAT`.

FIGURE 5-4: READS FROM FLASH PROGRAM MEMORY

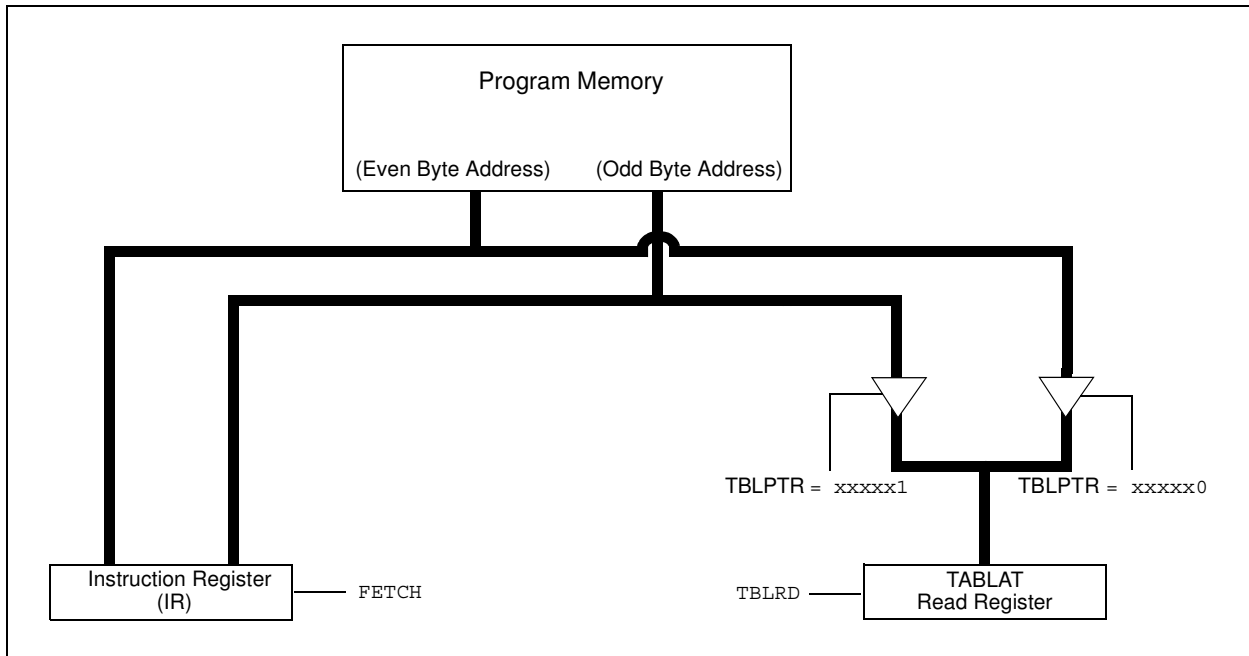

EXAMPLE 5-1: READING A FLASH PROGRAM MEMORY WORD

```
        MOVLW  CODE_ADDR_UPPER           ; Load TBLPTR with the base
        MOVWF  TBLPTRU                    ; address of the word
        MOVLW  CODE_ADDR_HIGH
        MOVWF  TBLPTRH
        MOVLW  CODE_ADDR_LOW
        MOVWF  TBLPTRL

READ_WORD
        TBLRD*+                          ; read into TABLAT and increment
        MOVF   TABLAT, W                  ; get data
        MOVWF  WORD_EVEN
        TBLRD*+                          ; read into TABLAT and increment
        MOVFW  TABLAT, W                  ; get data
        MOVWF  WORD_ODD
```

PIC18F6520/8520/6620/8620/6720/8720

5.4 Erasing Flash Program Memory

The minimum erase block is 32 words or 64 bytes. Only through the use of an external programmer, or through ICSP control, can larger blocks of program memory be bulk erased. Word erase in the Flash array is not supported.

When initiating an erase sequence from the microcontroller itself, a block of 64 bytes of program memory is erased. The Most Significant 16 bits of the TBLPTR<21:6> point to the block being erased. TBLPTR<5:0> are ignored.

The EECON1 register commands the erase operation. The EEPGD bit must be set to point to the Flash program memory. The WREN bit must be set to enable write operations. The FREE bit is set to select an erase operation.

For protection, the write initiate sequence for EECON2 must be used.

A long write is necessary for erasing the internal Flash. Instruction execution is halted while in a long write cycle. The long write will be terminated by the internal programming timer.

5.4.1 FLASH PROGRAM MEMORY ERASE SEQUENCE

The sequence of events for erasing a block of internal program memory location is:

1. Load Table Pointer with address of row being erased.
2. Set the EECON1 register for the erase operation:
 - set EEPGD bit to point to program memory;
 - clear the CFGS bit to access program memory;
 - set WREN bit to enable writes;
 - set FREE bit to enable the erase.
3. Disable interrupts.
4. Write 55h to EECON2.
5. Write AAh to EECON2.
6. Set the WR bit. This will begin the row erase cycle.
7. The CPU will stall for duration of the erase (about 2 ms using internal timer).
8. Execute a NOP.
9. Re-enable interrupts.

EXAMPLE 5-2: ERASING A FLASH PROGRAM MEMORY ROW

	MOVLW	CODE_ADDR_UPPER	; load TBLPTR with the base
	MOVWF	TBLPTRU	; address of the memory block
	MOVLW	CODE_ADDR_HIGH	
	MOVWF	TBLPTRH	
	MOVLW	CODE_ADDR_LOW	
	MOVWF	TBLPTRL	
ERASE_ROW			
	BSF	EECON1, EEPGD	; point to Flash program memory
	BCF	EECON1, CFGS	; access Flash program memory
	BSF	EECON1, WREN	; enable write to memory
	BSF	EECON1, FREE	; enable Row Erase operation
	BCF	INTCON, GIE	; disable interrupts
	MOVLW	55h	
	MOVWF	EECON2	; write 55H
Required	MOVLW	AAh	
Sequence	MOVWF	EECON2	; write AAH
	BSF	EECON1, WR	; start erase (CPU stall)
	NOP		
	BSF	INTCON, GIE	; re-enable interrupts

PIC18F6520/8520/6620/8620/6720/8720

5.5 Writing to Flash Program Memory

The minimum programming block is 4 words or 8 bytes. Word or byte programming is not supported.

Table writes are used internally to load the holding registers needed to program the Flash memory. There are 8 holding registers used by the table writes for programming.

Since the Table Latch (TABLAT) is only a single byte, the TBLWT instruction has to be executed 8 times for each programming operation. All of the table write operations will essentially be short writes, because only

the holding registers are written. At the end of updating 8 registers, the EECON1 register must be written to, to start the programming operation with a long write.

The long write is necessary for programming the internal Flash. Instruction execution is halted while in a long write cycle. The long write will be terminated by the internal programming timer.

The EEPROM on-chip timer controls the write time. The write/erase voltages are generated by an on-chip charge pump, rated to operate over the voltage range of the device for byte or word operations.

FIGURE 5-5: TABLE WRITES TO FLASH PROGRAM MEMORY

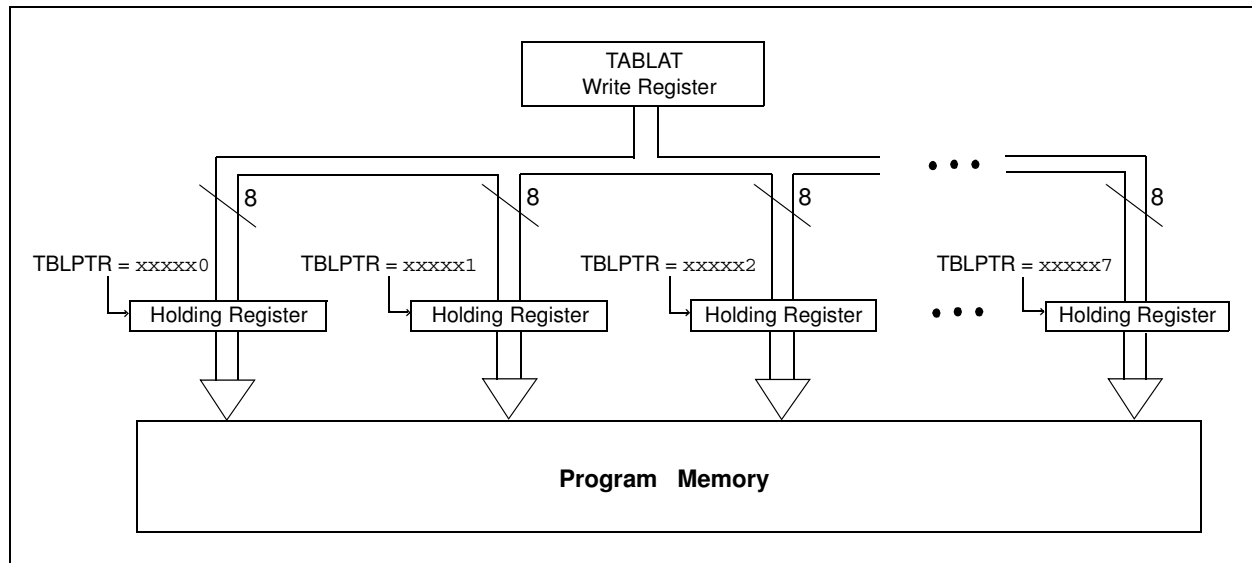

5.5.1 FLASH PROGRAM MEMORY WRITE SEQUENCE

The sequence of events for programming an internal program memory location should be:

1. Read 64 bytes into RAM.
2. Update data values in RAM as necessary.
3. Load Table Pointer with address being erased.
4. Do the row erase procedure.
5. Load Table Pointer with address of first byte being written.
6. Write the first 8 bytes into the holding registers with auto-increment.
7. Set the EECON1 register for the write operation:
 - set EEPGD bit to point to program memory
 - clear the CFGS bit to access program memory
 - set WREN to enable byte writes
8. Disable interrupts.

9. Write 55h to EECON2.
10. Write AAh to EECON2.
11. Set the WR bit. This will begin the write cycle.
12. The CPU will stall for duration of the write (about 2 ms using internal timer).
13. Execute a NOP.
14. Re-enable interrupts.
15. Repeat steps 6-14 seven times, to write 64 bytes.
16. Verify the memory (table read).

This procedure will require about 18 ms to update one row of 64 bytes of memory. An example of the required code is given in Example 5-3.

Note: Before setting the WR bit, the Table Pointer address needs to be within the intended address range of the eight bytes in the holding register.

PIC18F6520/8520/6620/8620/6720/8720

EXAMPLE 5-3: WRITING TO FLASH PROGRAM MEMORY

```
        MOVLW    D'64                ; number of bytes in erase block
        MOVWF    COUNTER
        MOVLW    BUFFER_ADDR_HIGH    ; point to buffer
        MOVWF    FSR0H
        MOVLW    BUFFER_ADDR_LOW
        MOVWF    FSR0L
        MOVLW    CODE_ADDR_UPPER     ; Load TBLPTR with the base
        MOVWF    TBLPTRU             ; address of the memory block
        MOVLW    CODE_ADDR_HIGH
        MOVWF    TBLPTRH
        MOVLW    CODE_ADDR_LOW
        MOVWF    TBLPTRL

READ_BLOCK
        TBLRD*+                       ; read into TABLAT, and inc
        MOVF     TABLAT, W            ; get data
        MOVWF    POSTINC0            ; store data
        DECFSZ   COUNTER             ; done?
        BRA     READ_BLOCK           ; repeat

MODIFY_WORD
        MOVLW    DATA_ADDR_HIGH     ; point to buffer
        MOVWF    FSR0H
        MOVLW    DATA_ADDR_LOW
        MOVWF    FSR0L
        MOVLW    NEW_DATA_LOW        ; update buffer word
        MOVWF    POSTINC0
        MOVLW    NEW_DATA_HIGH
        MOVWF    INDF0

ERASE_BLOCK
        MOVLW    CODE_ADDR_UPPER     ; load TBLPTR with the base
        MOVWF    TBLPTRU             ; address of the memory block
        MOVLW    CODE_ADDR_HIGH
        MOVWF    TBLPTRH
        MOVLW    CODE_ADDR_LOW
        MOVWF    TBLPTRL
        BSF     EECON1, EEPGD        ; point to Flash program memory
        BCF     EECON1, CFGS         ; access Flash program memory
        BSF     EECON1, WREN         ; enable write to memory
        BSF     EECON1, FREE         ; enable Row Erase operation
        BCF     INTCON, GIE          ; disable interrupts

        MOVLW    55h
        MOVWF    EECON2              ; write 55H
Required
Sequence
        MOVLW    AAh
        MOVWF    EECON2              ; write AAH
        BSF     EECON1, WR           ; start erase (CPU stall)
        NOP
        BSF     INTCON, GIE          ; re-enable interrupts
        TBLRD*-                       ; dummy read decrement

WRITE_BUFFER_BACK
        MOVLW    8                   ; number of write buffer groups of 8 bytes
        MOVWF    COUNTER_HI
        MOVLW    BUFFER_ADDR_HIGH    ; point to buffer
        MOVWF    FSR0H
        MOVLW    BUFFER_ADDR_LOW
        MOVWF    FSR0L

PROGRAM_LOOP
        MOVLW    8                   ; number of bytes in holding register
        MOVWF    COUNTER

WRITE_WORD_TO_HREGS
        MOVFF   POSTINC0, WREG       ; get low byte of buffer data
        ; present data to table latch
        TBLWT*+                       ; write data, perform a short write
        ; to internal TBLWT holding register.
        DECFSZ   COUNTER             ; loop until buffers are full
        BRA     WRITE_WORD_TO_HREGS
```

PIC18F6520/8520/6620/8620/6720/8720

EXAMPLE 5-3: WRITING TO FLASH PROGRAM MEMORY (CONTINUED)

PROGRAM_MEMORY				
	BSF	EECON1, EEPGD		; point to Flash program memory
	BCF	EECON1, CFGS		; access Flash program memory
	BSF	EECON1, WREN		; enable write to memory
	BCF	INTCON, GIE		; disable interrupts
	MOVLW	55h		
	MOVWF	EECON2		; write 55H
Required Sequence	MOVLW	AAh		
	MOVWF	EECON2		; write AAH
	BSF	EECON1, WR		; start program (CPU stall)
	NOP			
	BSF	INTCON, GIE		; re-enable interrupts
	DECFSZ	COUNTER_HI		; loop until done
	BRA	PROGRAM_LOOP		
	BCF	EECON1, WREN		; disable write to memory

5.5.2 WRITE VERIFY

Depending on the application, good programming practice may dictate that the value written to the memory should be verified against the original value. This should be used in applications where excessive writes can stress bits near the specification limit.

5.5.3 UNEXPECTED TERMINATION OF WRITE OPERATION

If a write is terminated by an unplanned event, such as loss of power or an unexpected Reset, the memory location just programmed should be verified and reprogrammed if needed. The WRERR bit is set when a write operation is interrupted by a MCLR Reset, or a WDT Time-out Reset during normal operation. In these situations, users can check the WRERR bit and rewrite the location.

5.5.4 PROTECTION AGAINST SPURIOUS WRITES

To protect against spurious writes to Flash program memory, the write initiate sequence must also be followed. See **Section 23.0 “Special Features of the CPU”** for more detail.

5.6 Flash Program Operation During Code Protection

See **Section 23.0 “Special Features of the CPU”** for details on code protection of Flash program memory.

TABLE 5-2: REGISTERS ASSOCIATED WITH PROGRAM FLASH MEMORY

Name	Bit 7	Bit 6	Bit 5	Bit 4	Bit 3	Bit 2	Bit 1	Bit 0	Value on POR, BOR	Value on all other Resets
TBLPTRU	—	—	bit 21	Program Memory Table Pointer Upper Byte (TBLPTR<20:16>)					--00 0000	--00 0000
TBPLTRH	Program Memory Table Pointer High Byte (TBLPTR<15:8>)								0000 0000	0000 0000
TBLPTRL	Program Memory Table Pointer High Byte (TBLPTR<7:0>)								0000 0000	0000 0000
TABLAT	Program Memory Table Latch								0000 0000	0000 0000
INTCON	GIE/GIEH	PEIE/GIEL	TMR0IE	INTE	RBIE	TMR0IF	INTF	RBIF	0000 0000	0000 0000
EECON2	EEPROM Control Register 2 (not a physical register)								—	—
EECON1	EEPGD	CFGFS	—	FREE	WRERR	WREN	WR	RD	xx-0 x000	uu-0 u000
IPR2	—	CMIP	—	EEIP	BCLIP	LVDIP	TMR3IP	CCP2IP	---1 1111	---1 1111
PIR2	—	CMIF	—	EEIF	BCLIF	LVDIF	TMR3IF	CCP2IF	---0 0000	---0 0000
PIE2	—	CMIE	—	EEIE	BCLIE	LVDIE	TMR3IE	CCP2IE	---0 0000	---0 0000

Legend: x = unknown, u = unchanged, r = reserved, - = unimplemented, read as '0'.
Shaded cells are not used during Flash/EEPROM access.

PIC18F6520/8520/6620/8620/6720/8720

NOTES:

PIC18F6520/8520/6620/8620/6720/8720

6.0 EXTERNAL MEMORY INTERFACE

Note: The External Memory Interface is not implemented on PIC18F6X20 (64-pin) devices.

The External Memory Interface is a feature of the PIC18F8X20 devices that allows the controller to access external memory devices (such as Flash, EPROM, SRAM, etc.) as program or data memory.

The physical implementation of the interface uses 27 pins. These pins are reserved for external address/data bus functions; they are multiplexed with I/O port pins on four ports. Three I/O ports are multiplexed with the address/data bus, while the fourth port is multiplexed with the bus control signals. The I/O port functions are enabled when the EBDIS bit in the MEMCON register is set (see Register 6-1). A list of the multiplexed pins and their functions is provided in Table 6-1.

As implemented in the PIC18F8X20 devices, the interface operates in a similar manner to the external memory interface introduced on PIC18C601/801 microcontrollers. The most notable difference is that the interface on PIC18F8X20 devices only operates in 16-bit modes. The 8-bit mode is not supported.

For a more complete discussion of the operating modes that use the external memory interface, refer to **Section 4.1.1 “PIC18F8X20 Program Memory Modes”**.

6.1 Program Memory Modes and the External Memory Interface

As previously noted, PIC18F8X20 controllers are capable of operating in any one of four program memory modes, using combinations of on-chip and external program memory. The functions of the multiplexed port pins depend on the program memory mode selected, as well as the setting of the EBDIS bit.

In **Microprocessor Mode**, the external bus is always active and the port pins have only the external bus function.

In **Microcontroller Mode**, the bus is not active and the pins have their port functions only. Writes to the MEMCOM register are not permitted.

In **Microprocessor with Boot Block** or **Extended Microcontroller Mode**, the external program memory bus shares I/O port functions on the pins. When the device is fetching or doing table read/table write operations on the external program memory space, the pins will have the external bus function. If the device is fetching and accessing internal program memory locations only, the EBDIS control bit will change the pins from external memory to I/O port functions. When EBDIS = 0, the pins function as the external bus. When EBDIS = 1, the pins function as I/O ports.

Note: Maximum FOSC for the PIC18FX520 is limited to 25 MHz when using the external memory interface.

REGISTER 6-1: MEMCON REGISTER

R/W-0	U-0	R/W-0	R/W-0	U-0	U-0	R/W-0	R/W-0
EBDIS	—	WAIT1	WAIT0	—	—	WM1	WM0
bit7						bit0	

- bit 7 **EBDIS:** External Bus Disable bit
 1 = External system bus disabled, all external bus drivers are mapped as I/O ports
 0 = External system bus enabled and I/O ports are disabled
- bit 6 **Unimplemented:** Read as '0'
- bit 5-4 **WAIT<1:0>:** Table Reads and Writes Bus Cycle Wait Count bits
 11 = Table reads and writes will wait 0 T_{CY}
 10 = Table reads and writes will wait 1 T_{CY}
 01 = Table reads and writes will wait 2 T_{CY}
 00 = Table reads and writes will wait 3 T_{CY}
- bit 3-2 **Unimplemented:** Read as '0'
- bit 1-0 **WM<1:0>:** TBLWRT Operation with 16-bit Bus bits
 1x = Word Write mode: TABLAT<0> and TABLAT<1> word output, \overline{WRH} active when TABLAT<1> written
 01 = Byte Select mode: TABLAT data copied on both MSB and LSB, \overline{WRH} and (\overline{UB} or \overline{LB}) will activate
 00 = Byte Write mode: TABLAT data copied on both MSB and LSB, \overline{WRH} or \overline{WRL} will activate

Legend:

R = Readable bit W = Writable bit U = Unimplemented bit, read as '0'
 - n = Value at POR '1' = Bit is set '0' = Bit is cleared x = Bit is unknown

PIC18F6520/8520/6620/8620/6720/8720

If the device fetches or accesses external memory while $EBDIS = 1$, the pins will switch to external bus. If the $EBDIS$ bit is set by a program executing from external memory, the action of setting the bit will be delayed until the program branches into the internal memory. At that time, the pins will change from external bus to I/O ports.

When the device is executing out of internal memory ($EBDIS = 0$) in Microprocessor with Boot Block mode, or Extended Microcontroller mode, the control signals will NOT be active. They will go to a state where the $AD_{<15:0>}$ and $A_{<19:16>}$ are tri-state; the \overline{CE} , \overline{OE} , \overline{WRH} , \overline{WRL} , \overline{UB} and \overline{LB} signals are '1' and ALE and $BA0$ are '0'.

TABLE 6-1: PIC18F8X20 EXTERNAL BUS – I/O PORT FUNCTIONS

Name	Port	Bit	Function
RD0/AD0	PORTD	bit 0	Input/Output or System Bus Address bit 0 or Data bit 0.
RD1/AD1	PORTD	bit 1	Input/Output or System Bus Address bit 1 or Data bit 1.
RD2/AD2	PORTD	bit 2	Input/Output or System Bus Address bit 2 or Data bit 2.
RD3/AD3	PORTD	bit 3	Input/Output or System Bus Address bit 3 or Data bit 3.
RD4/AD4	PORTD	bit 4	Input/Output or System Bus Address bit 4 or Data bit 4.
RD5/AD5	PORTD	bit 5	Input/Output or System Bus Address bit 5 or Data bit 5.
RD6/AD6	PORTD	bit 6	Input/Output or System Bus Address bit 6 or Data bit 6.
RD7/AD7	PORTD	bit 7	Input/Output or System Bus Address bit 7 or Data bit 7.
RE0/AD8	PORTE	bit 0	Input/Output or System Bus Address bit 8 or Data bit 8.
RE1/AD9	PORTE	bit 1	Input/Output or System Bus Address bit 9 or Data bit 9.
RE2/AD10	PORTE	bit 2	Input/Output or System Bus Address bit 10 or Data bit 10.
RE3/AD11	PORTE	bit 3	Input/Output or System Bus Address bit 11 or Data bit 11.
RE4/AD12	PORTE	bit 4	Input/Output or System Bus Address bit 12 or Data bit 12.
RE5/AD13	PORTE	bit 5	Input/Output or System Bus Address bit 13 or Data bit 13.
RE6/AD14	PORTE	bit 6	Input/Output or System Bus Address bit 14 or Data bit 14.
RE7/AD15	PORTE	bit 7	Input/Output or System Bus Address bit 15 or Data bit 15.
RH0/A16	PORTH	bit 0	Input/Output or System Bus Address bit 16.
RH1/A17	PORTH	bit 1	Input/Output or System Bus Address bit 17.
RH2/A18	PORTH	bit 2	Input/Output or System Bus Address bit 18.
RH3/A19	PORTH	bit 3	Input/Output or System Bus Address bit 19.
RJ0/ALE	PORTJ	bit 0	Input/Output or System Bus Address Latch Enable (ALE) Control pin.
RJ1/ \overline{OE}	PORTJ	bit 1	Input/Output or System Bus Output Enable (\overline{OE}) Control pin.
RJ2/ \overline{WRL}	PORTJ	bit 2	Input/Output or System Bus Write Low (\overline{WRL}) Control pin.
RJ3/ \overline{WRH}	PORTJ	bit 3	Input/Output or System Bus Write High (\overline{WRH}) Control pin.
RJ4/BA0	PORTJ	bit 4	Input/Output or System Bus Byte Address bit 0.
RJ5/ \overline{CE}	PORTJ	bit 5	Input/Output or System Bus Chip Enable (\overline{CE}) Control pin.
RJ6/ \overline{LB}	PORTJ	bit 6	Input/Output or System Bus Lower Byte Enable (\overline{LB}) Control pin.
RJ7/ \overline{UB}	PORTJ	bit 7	Input/Output or System Bus Upper Byte Enable (\overline{UB}) Control pin.

PIC18F6520/8520/6620/8620/6720/8720

6.2 16-bit Mode

The External Memory Interface implemented in PIC18F8X20 devices operates only in 16-bit mode. The mode selection is not software configurable, but is programmed via the configuration bits.

The WM<1:0> bits in the MEMCON register determine three types of connections in 16-bit mode. They are referred to as:

- 16-bit Byte Write
- 16-bit Word Write
- 16-bit Byte Select

These three different configurations allow the designer maximum flexibility in using 8-bit and 16-bit memory devices.

For all 16-bit modes, the Address Latch Enable (ALE) pin indicates that the address bits A<15:0> are available on the External Memory Interface bus. Following the address latch, the Output Enable signal (\overline{OE}) will enable both bytes of program memory at once to form a 16-bit instruction word. The Chip Enable signal (\overline{CE}) is active at any time that the microcontroller accesses external memory, whether reading or writing; it is inactive (asserted high) whenever the device is in Sleep mode.

In Byte Select mode, JEDEC standard Flash memories will require BA0 for the byte address line and one I/O line to select between Byte and Word mode. The other 16-bit modes do not need BA0. JEDEC standard static RAM memories will use the UB or LB signals for byte selection.

6.2.1 16-BIT BYTE WRITE MODE

Figure 6-1 shows an example of 16-bit Byte Write mode for PIC18F8X20 devices. This mode is used for two separate 8-bit memories connected for 16-bit operation. This generally includes basic EPROM and Flash devices. It allows table writes to byte-wide external memories.

During a TBLWT instruction cycle, the TABLAT data is presented on the upper and lower bytes of the AD15:AD0 bus. The appropriate \overline{WRH} or \overline{WRL} control line is strobed on the LSB of the TBLPTR.

FIGURE 6-1: 16-BIT BYTE WRITE MODE EXAMPLE

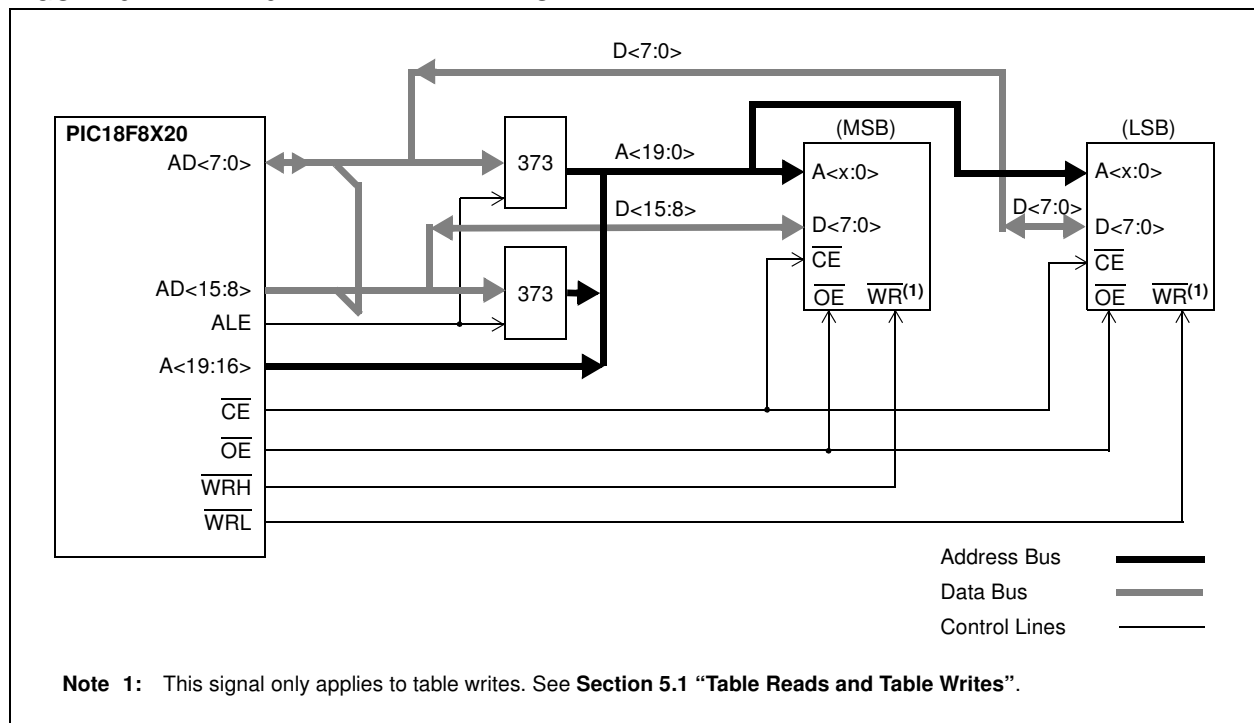

PIC18F6520/8520/6620/8620/6720/8720

6.2.2 16-BIT WORD WRITE MODE

Figure 6-2 shows an example of 16-bit Word Write mode for PIC18F8X20 devices. This mode is used for word-wide memories, which includes some of the EPROM and Flash type memories. This mode allows opcode fetches and table reads from all forms of 16-bit memory and table writes to any type of word-wide external memories. This method makes a distinction between TBLWT cycles to even or odd addresses.

During a TBLWT cycle to an even address (TBLPTR<0> = 0), the TABLAT data is transferred to a holding latch and the external address data bus is tri-stated for the data portion of the bus cycle. No write signals are activated.

During a TBLWT cycle to an odd address (TBLPTR<0> = 1), the TABLAT data is presented on the upper byte of the AD15:AD0 bus. The contents of the holding latch are presented on the lower byte of the AD15:AD0 bus.

The WRH signal is strobed for each write cycle; the WRL pin is unused. The signal on the BA0 pin indicates the LSB of TBLPTR, but it is left unconnected. Instead, the UB and LB signals are active to select both bytes. The obvious limitation to this method is that the table write must be done in pairs on a specific word boundary to correctly write a word location.

FIGURE 6-2: 16-BIT WORD WRITE MODE EXAMPLE

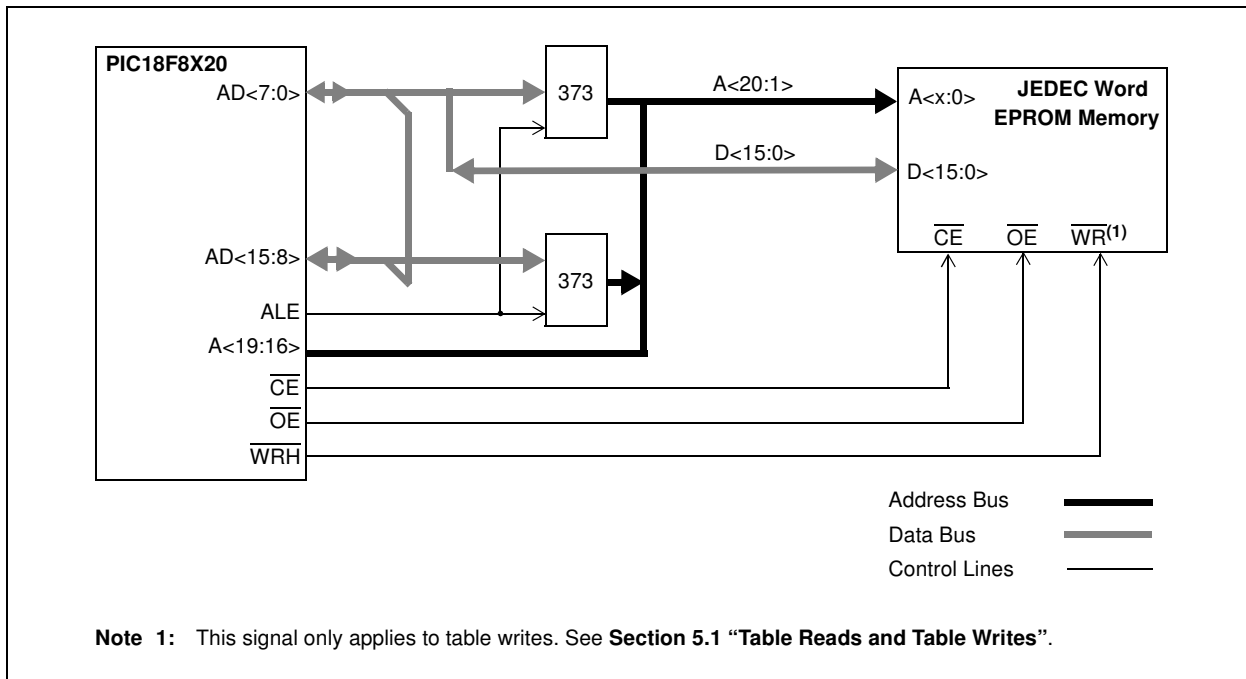

PIC18F6520/8520/6620/8620/6720/8720

6.2.3 16-BIT BYTE SELECT MODE

Figure 6-3 shows an example of 16-bit Byte Select mode for PIC18F8X20 devices. This mode allows table write operations to word-wide external memories with byte selection capability. This generally includes both word-wide Flash and SRAM devices.

During a TBLWT cycle, the TABLAT data is presented on the upper and lower byte of the AD15:AD0 bus. The WRH signal is strobed for each write cycle; the WRL pin is not used. The BA0 or $\overline{UB}/\overline{LB}$ signals are used to select the byte to be written, based on the Least Significant bit of the TBLPTR register.

Flash and SRAM devices use different control signal combinations to implement Byte Select mode. JEDEC standard Flash memories require that a controller I/O port pin be connected to the memory's BYTE/WORD pin to provide the select signal. They also use the BA0 signal from the controller as a byte address. JEDEC standard static RAM memories, on the other hand, use the \overline{UB} or \overline{LB} signals to select the byte.

FIGURE 6-3: 16-BIT BYTE SELECT MODE EXAMPLE

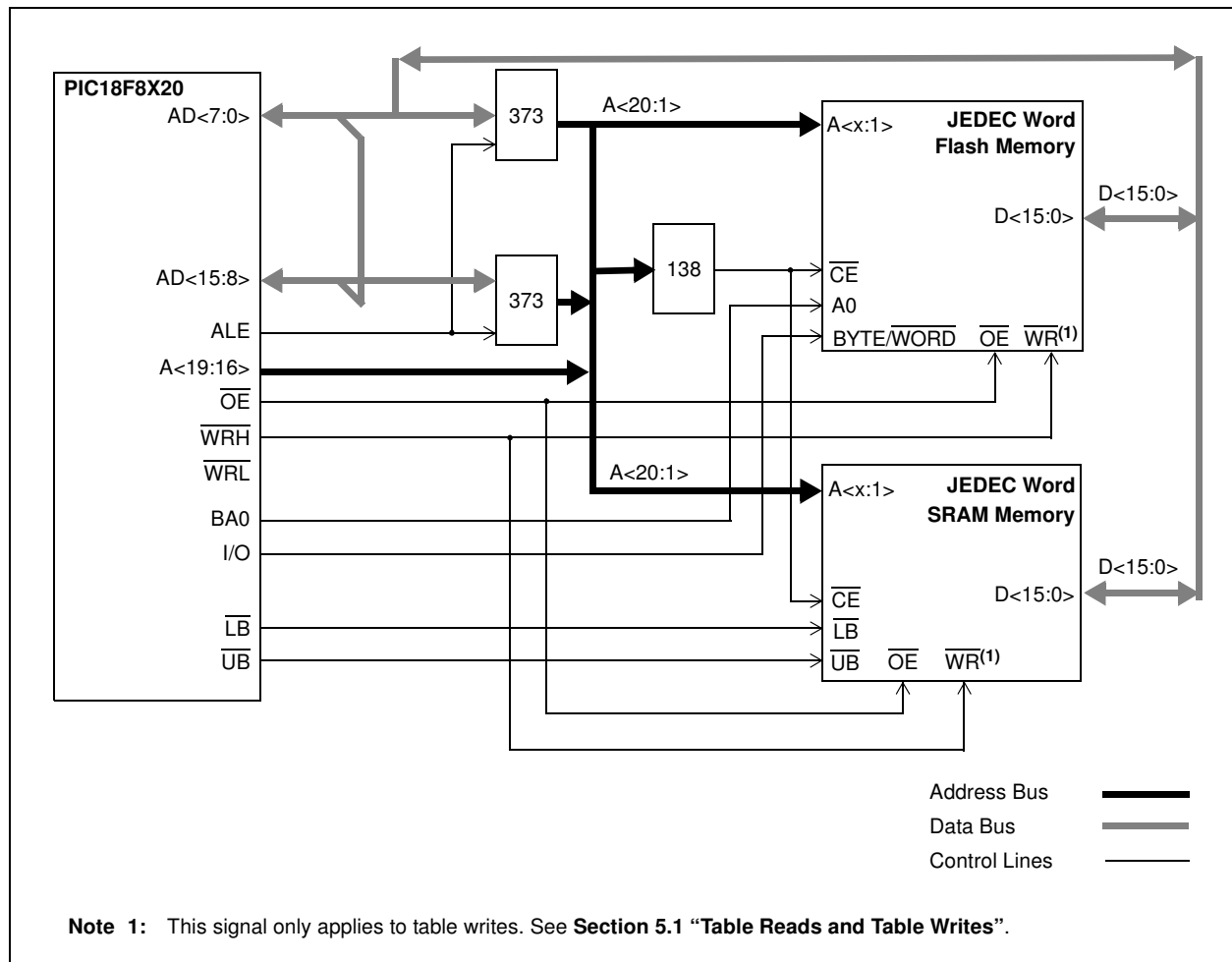

PIC18F6520/8520/6620/8620/6720/8720

6.2.4 16-BIT MODE TIMING

The presentation of control signals on the external memory bus is different for the various operating modes. Typical signal timing diagrams are shown in Figure 6-4 through Figure 6-6.

FIGURE 6-4: EXTERNAL MEMORY BUS TIMING FOR TBLRD (MICROPROCESSOR MODE)

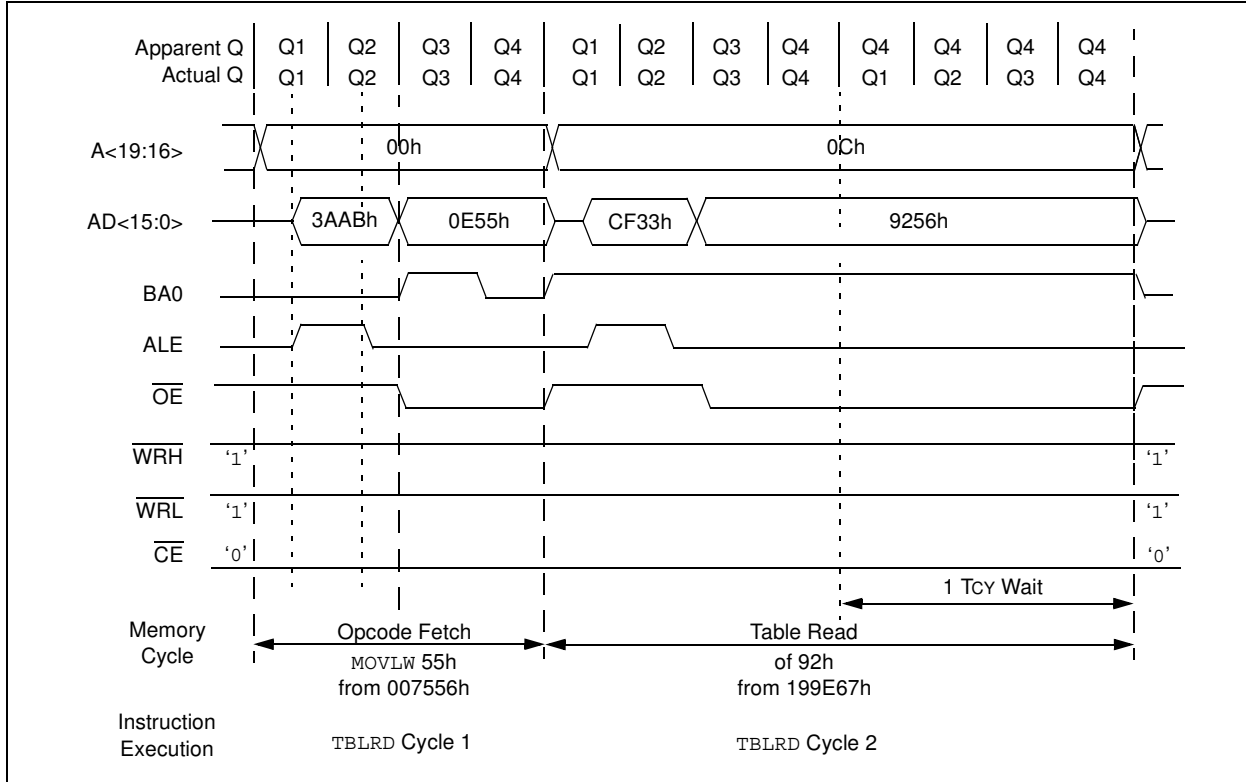
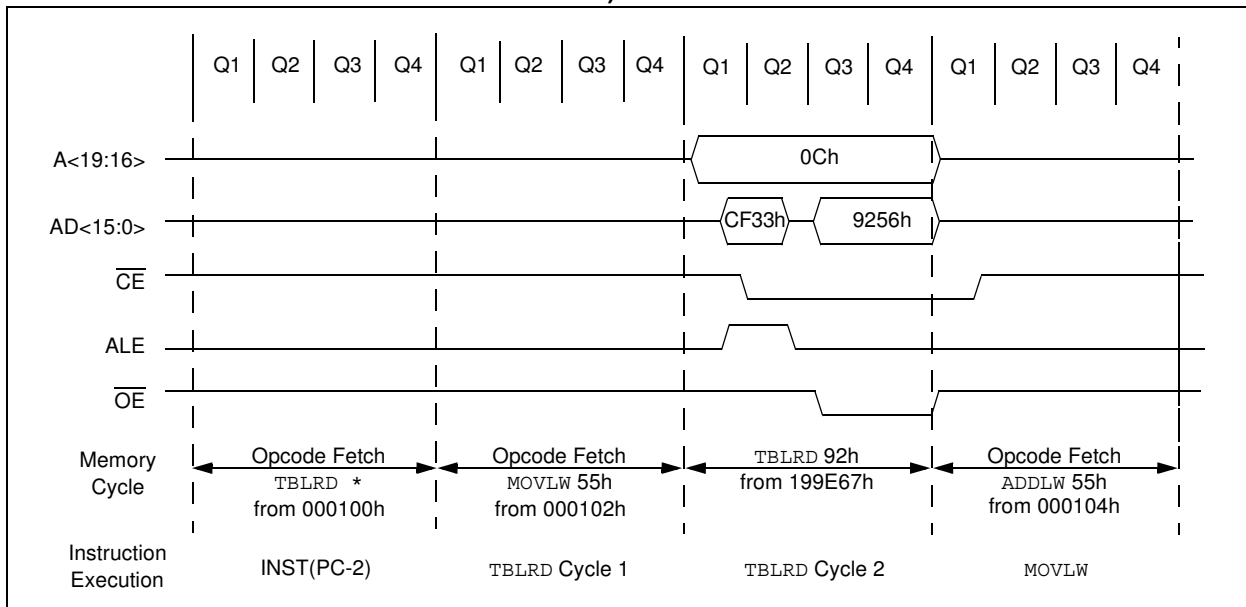
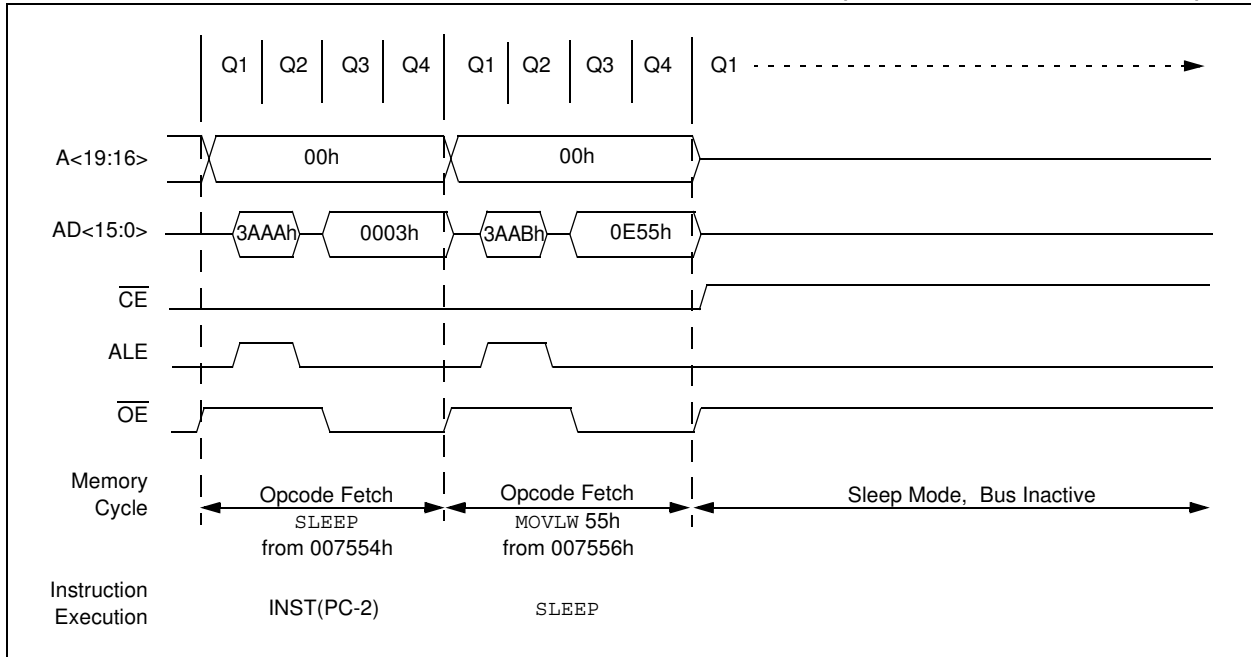

FIGURE 6-5: EXTERNAL MEMORY BUS TIMING FOR TBLRD (EXTENDED MICROCONTROLLER MODE)



PIC18F6520/8520/6620/8620/6720/8720

FIGURE 6-6: EXTERNAL MEMORY BUS TIMING FOR SLEEP (MICROPROCESSOR MODE)



PIC18F6520/8520/6620/8620/6720/8720

NOTES:

PIC18F6520/8520/6620/8620/6720/8720

7.0 DATA EEPROM MEMORY

The data EEPROM is readable and writable during normal operation over the entire V_{DD} range. The data memory is not directly mapped in the register file space. Instead, it is indirectly addressed through the Special Function Registers (SFR).

There are five SFRs used to read and write the program and data EEPROM memory. These registers are:

- EECON1
- EECON2
- EEDATA
- EEADRH
- EEADR

The EEPROM data memory allows byte read and write. When interfacing to the data memory block, EEDATA holds the 8-bit data for read/write. EEADR and EEADRH hold the address of the EEPROM location being accessed. These devices have 1024 bytes of data EEPROM with an address range from 00h to 3FFh.

The EEPROM data memory is rated for high erase/write cycles. A byte write automatically erases the location and writes the new data (erase-before-write). The write time is controlled by an on-chip timer. The write time will vary with voltage and temperature, as well as from chip to chip. Please refer to parameter D122 (see **Section 26.0 “Electrical Characteristics”**) for exact limits.

7.1 EEADR and EEADRH

The address register pair can address up to a maximum of 1024 bytes of data EEPROM. The two Most Significant bits of the address are stored in EEADRH, while the remaining eight Least Significant bits are stored in EEADR. The six Most Significant bits of EEADRH are unused and are read as ‘0’.

7.2 EECON1 and EECON2 Registers

EECON1 is the control register for EEPROM memory accesses.

EECON2 is not a physical register. Reading EECON2 will read all ‘0’s. The EECON2 register is used exclusively in the EEPROM write sequence.

Control bits, RD and WR, initiate read and write operations, respectively. These bits cannot be cleared, only set, in software. They are cleared in hardware at the completion of the read or write operation. The inability to clear the WR bit in software prevents the accidental or premature termination of a write operation.

The WREN bit, when set, will allow a write operation. On power-up, the WREN bit is clear. The WRERR bit is set when a write operation is interrupted by a MCLR Reset or a WDT Time-out Reset during normal operation. In these situations, the user can check the WRERR bit and rewrite the location. It is necessary to reload the data and address registers (EEDATA and EEADR) due to the Reset condition forcing the contents of the registers to zero.

Note: Interrupt flag bit, EEIF in the PIR2 register, is set when write is complete. It must be cleared in software.

PIC18F6520/8520/6620/8620/6720/8720

REGISTER 7-1: EECON1 REGISTER (ADDRESS FA6h)

R/W-x	R/W-x	U-0	R/W-0	R/W-x	R/W-0	R/S-0	R/S-0	
EEPGD	CFGS	—	FREE	WRERR	WREN	WR	RD	
bit 7								bit 0

- bit 7 **EEPGD:** Flash Program/Data EEPROM Memory Select bit
 1 = Access Flash program memory
 0 = Access data EEPROM memory
- bit 6 **CFGS:** Flash Program/Data EEPROM or Configuration Select bit
 1 = Access configuration or calibration registers
 0 = Access Flash program or data EEPROM memory
- bit 5 **Unimplemented:** Read as '0'
- bit 4 **FREE:** Flash Row Erase Enable bit
 1 = Erase the program memory row addressed by TBLPTR on the next WR command
 (cleared by completion of erase operation)
 0 = Perform write only
- bit 3 **WRERR:** Flash Program/Data EEPROM Error Flag bit
 1 = A write operation is prematurely terminated
 (any MCLR or any WDT Reset during self-timed programming in normal operation)
 0 = The write operation completed
Note: When a WRERR occurs, the EEPGD or FREE bits are not cleared. This allows tracing of the error condition.
- bit 2 **WREN:** Flash Program/Data EEPROM Write Enable bit
 1 = Allows write cycles to Flash program/data EEPROM
 0 = Inhibits write cycles to Flash program/data EEPROM
- bit 1 **WR:** Write Control bit
 1 = Initiates a data EEPROM erase/write cycle, or a program memory erase cycle or write cycle.
 (The operation is self-timed and the bit is cleared by hardware once write is complete. The WR bit can only be set (not cleared) in software.)
 0 = Write cycle to the EEPROM is complete
- bit 0 **RD:** Read Control bit
 1 = Initiates an EEPROM read. (Read takes one cycle. RD is cleared in hardware. The RD bit can only be set (not cleared) in software. RD bit cannot be set when EEPGD = 1.)
 0 = Does not initiate an EEPROM read

Legend:

R = Readable bit	W = Writable bit	U = Unimplemented bit, read as '0'
- n = Value at POR	'1' = Bit is set	'0' = Bit is cleared x = Bit is unknown

PIC18F6520/8520/6620/8620/6720/8720

7.3 Reading the Data EEPROM Memory

To read a data memory location, the user must write the address to the EEADRH:EEADR register pair, clear the EEPGD control bit (EECON1<7>), clear the CFGS

control bit (EECON1<6>) and then set the RD control bit (EECON1<0>). The data is available for the very next instruction cycle; therefore, the EEDATA register can be read by the next instruction. EEDATA will hold this value until another read operation, or until it is written to by the user (during a write operation).

EXAMPLE 7-1: DATA EEPROM READ

```
MOVLW DATA_EE_ADDRH ;
MOVWF EEADRH ; Upper bits of Data Memory Address to read
MOVLW DATA_EE_ADDR ;
MOVWF EEADR ; Lower bits of Data Memory Address to read
BCF EECON1, EEPGD ; Point to DATA memory
BCF EECON1, CFGS ; Access EEPROM
BSF EECON1, RD ; EEPROM Read
MOVF EEDATA, W ; W = EEDATA
```

7.4 Writing to the Data EEPROM Memory

To write an EEPROM data location, the address must first be written to the EEADRH:EEADR register pair and the data written to the EEDATA register. Then the sequence in Example 7-2 must be followed to initiate the write cycle.

The write will not initiate if the above sequence is not exactly followed (write 55h to EECON2, write AAh to EECON2, then set WR bit) for each byte. It is strongly recommended that interrupts be disabled during this code segment.

Additionally, the WREN bit in EECON1 must be set to enable writes. This mechanism prevents accidental writes to data EEPROM due to unexpected code execution (i.e., runaway programs). The WREN bit

should be kept clear at all times, except when updating the EEPROM. The WREN bit is not cleared by hardware

After a write sequence has been initiated, EECON1, EEADRH, EEADR and EEDATA cannot be modified. The WR bit will be inhibited from being set unless the WREN bit is set. Both WR and WREN cannot be set with the same instruction.

At the completion of the write cycle, the WR bit is cleared in hardware and the EEPROM Write Complete Interrupt Flag bit (EEIF) is set. The user may either enable this interrupt, or poll this bit. EEIF must be cleared by software.

EXAMPLE 7-2: DATA EEPROM WRITE

```
MOVLW DATA_EE_ADDRH ;
MOVWF EEADRH ; Upper bits of Data Memory Address to write
MOVLW DATA_EE_ADDR ;
MOVWF EEADR ; Lower bits of Data Memory Address to write
MOVLW DATA_EE_DATA ;
MOVWF EEDATA ; Data Memory Value to write
BCF EECON1, EEPGD ; Point to DATA memory
BCF EECON1, CFGS ; Access EEPROM
BSF EECON1, WREN ; Enable writes

BCF INTCON, GIE ; Disable Interrupts
MOVLW 55h ;
Required MOVWF EECON2 ; Write 55h
Sequence MOVLW AAh ;
MOVWF EECON2 ; Write AAh
BSF EECON1, WR ; Set WR bit to begin write
BSF INTCON, GIE ; Enable Interrupts

; User code execution
BCF EECON1, WREN ; Disable writes on write complete (EEIF set)
```

PIC18F6520/8520/6620/8620/6720/8720

7.5 Write Verify

Depending on the application, good programming practice may dictate that the value written to the memory should be verified against the original value. This should be used in applications where excessive writes can stress bits near the specification limit.

7.6 Protection Against Spurious Write

There are conditions when the user may not want to write to the data EEPROM memory. To protect against spurious EEPROM writes, various mechanisms have been built-in. On power-up, the WREN bit is cleared. Also, the Power-up Timer (72 ms duration) prevents EEPROM write.

The write initiate sequence and the WREN bit together help prevent an accidental write during brown-out, power glitch, or software malfunction.

7.7 Operation During Code-Protect

Data EEPROM memory has its own code-protect mechanism. External read and write operations are disabled if either of these mechanisms are enabled.

The microcontroller itself can both read and write to the internal data EEPROM, regardless of the state of the code-protect configuration bit. Refer to **Section 23.0 “Special Features of the CPU”** for additional information.

7.8 Using the Data EEPROM

The data EEPROM is a high endurance, byte addressable array that has been optimized for the storage of frequently changing information (e.g., program variables or other data that are updated often). Frequently changing values will typically be updated more often than specification D124. If this is not the case, an array refresh must be performed. For this reason, variables that change infrequently (such as constants, IDs, calibration, etc.) should be stored in Flash program memory.

A simple data EEPROM refresh routine is shown in Example 7-3.

Note: If data EEPROM is only used to store constants and/or data that changes rarely, an array refresh is likely not required. See specification D124.

EXAMPLE 7-3: DATA EEPROM REFRESH ROUTINE

```
CLRF    EEADR           ; Start at address 0
CLRF    EEADRH          ;
BCF     EECON1, CFGS    ; Set for memory
BCF     EECON1, EEPGD   ; Set for Data EEPROM
BCF     INTCON, GIE     ; Disable interrupts
BSF     EECON1, WREN    ; Enable writes
Loop    ; Loop to refresh array
        BSF     EECON1, RD      ; Read current address
        MOVLW  55h             ;
        MOVWF  EECON2          ; Write 55h
        MOVLW  AAh             ;
        MOVWF  EECON2          ; Write AAh
        BSF     EECON1, WR     ; Set WR bit to begin write
        BTFSC  EECON1, WR     ; Wait for write to complete
        BRA    $-2
        INCFSZ EEADR, F       ; Increment address
        BRA    Loop           ; Not zero, do it again
        INCFSZ EEADRH, F     ; Increment the high address
        BRA    Loop           ; Not zero, do it again

        BCF     EECON1, WREN   ; Disable writes
        BSF     INTCON, GIE    ; Enable interrupts
```

PIC18F6520/8520/6620/8620/6720/8720

TABLE 7-1: REGISTERS ASSOCIATED WITH DATA EEPROM MEMORY

Name	Bit 7	Bit 6	Bit 5	Bit 4	Bit 3	Bit 2	Bit 1	Bit 0	Value on POR, BOR	Value on all other Resets
INTCON	GIE/GIEH	PEIE/GIEL	TMR0IE	INT0IE	RBIE	TMR0IF	INT0IF	RBIF	0000 0000	0000 0000
EEADRH	—	—	—	—	—	—	EE Addr Register High		---- --00	---- --00
EEADR	EEPROM Address Register								0000 0000	0000 0000
EEDATA	EEPROM Data Register								0000 0000	0000 0000
EECON2	EEPROM Control Register 2 (not a physical register)								---- ----	---- ----
EECON1	EEPGD	CFGS	—	FREE	WRERR	WREN	WR	RD	xx-0 x000	uu-0 u000
IPR2	—	CMIP	—	EEIP	BCLIP	LVDIP	TMR3IP	CCP2IP	---1 1111	---1 1111
PIR2	—	CMIF	—	EEIF	BCLIF	LVDIF	TMR3IF	CCP2IF	---0 0000	---0 0000
PIE2	—	CMIE	—	EEIE	BCLIE	LVDIE	TMR3IE	CCP2IE	---0 0000	---0 0000

Legend: x = unknown, u = unchanged, r = reserved, — = unimplemented, read as '0'.
Shaded cells are not used during Flash/EEPROM access.

PIC18F6520/8520/6620/8620/6720/8720

NOTES:

PIC18F6520/8520/6620/8620/6720/8720

8.0 8 X 8 HARDWARE MULTIPLIER

8.1 Introduction

An 8 x 8 hardware multiplier is included in the ALU of the PIC18FXX20 devices. By making the multiply a hardware operation, it completes in a single instruction cycle. This is an unsigned multiply that gives a 16-bit result. The result is stored in the 16-bit product register pair (PRODH:PRODL). The multiplier does not affect any flags in the ALUSTA register.

Making the 8 x 8 multiplier execute in a single cycle gives the following advantages:

- Higher computational throughput
- Reduces code size requirements for multiply algorithms

The performance increase allows the device to be used in applications previously reserved for Digital Signal Processors.

Table 8-1 shows a performance comparison between enhanced devices using the single-cycle hardware multiply and performing the same function without the hardware multiply.

8.2 Operation

Example 8-1 shows the sequence to do an 8 x 8 unsigned multiply. Only one instruction is required when one argument of the multiply is already loaded in the WREG register.

Example 8-2 shows the sequence to do an 8 x 8 signed multiply. To account for the sign bits of the arguments, each argument's Most Significant bit (MSb) is tested and the appropriate subtractions are done.

EXAMPLE 8-1: 8 x 8 UNSIGNED MULTIPLY ROUTINE

```
MOVWF ARG1, W ;
MULWF ARG2 ; ARG1 * ARG2 ->
; PRODH:PRODL
```

EXAMPLE 8-2: 8 x 8 SIGNED MULTIPLY ROUTINE

```
MOVWF ARG1, W ;
MULWF ARG2 ; ARG1 * ARG2 ->
; PRODH:PRODL
BTFSC ARG2, SB ; Test Sign Bit
SUBWF PRODH, F ; PRODH = PRODH
; - ARG1
MOVWF ARG2, W ;
BTFSC ARG1, SB ; Test Sign Bit
SUBWF PRODH, F ; PRODH = PRODH
; - ARG2
```

TABLE 8-1: PERFORMANCE COMPARISON

Routine	Multiply Method	Program Memory (Words)	Cycles (Max)	Time		
				@ 40 MHz	@ 10 MHz	@ 4 MHz
8 x 8 unsigned	Without hardware multiply	13	69	6.9 μs	27.6 μs	69 μs
	Hardware multiply	1	1	100 ns	400 ns	1 μs
8 x 8 signed	Without hardware multiply	33	91	9.1 μs	36.4 μs	91 μs
	Hardware multiply	6	6	600 ns	2.4 μs	6 μs
16 x 16 unsigned	Without hardware multiply	21	242	24.2 μs	96.8 μs	242 μs
	Hardware multiply	28	28	2.8 μs	11.2 μs	28 μs
16 x 16 signed	Without hardware multiply	52	254	25.4 μs	102.6 μs	254 μs
	Hardware multiply	35	40	4.0 μs	16.0 μs	40 μs

PIC18F6520/8520/6620/8620/6720/8720

Example 8-3 shows the sequence to do a 16 x 16 unsigned multiply. Equation 8-1 shows the algorithm that is used. The 32-bit result is stored in four registers, RES3:RES0.

EQUATION 8-1: 16 x 16 UNSIGNED MULTIPLICATION ALGORITHM

$$\begin{aligned} \text{RES3:RES0} &= \text{ARG1H:ARG1L} \cdot \text{ARG2H:ARG2L} \\ &= (\text{ARG1H} \cdot \text{ARG2H} \cdot 2^{16}) + \\ &\quad (\text{ARG1H} \cdot \text{ARG2L} \cdot 2^8) + \\ &\quad (\text{ARG1L} \cdot \text{ARG2H} \cdot 2^8) + \\ &\quad (\text{ARG1L} \cdot \text{ARG2L}) \end{aligned}$$

EXAMPLE 8-3: 16 x 16 UNSIGNED MULTIPLY ROUTINE

```

MOVF ARG1L, W
MULWF ARG2L ; ARG1L * ARG2L ->
; PRODH:PRODL

MOVFF PRODH, RES1 ;
MOVFF PRODL, RES0 ;
;

MOVF ARG1H, W
MULWF ARG2H ; ARG1H * ARG2H ->
; PRODH:PRODL

MOVFF PRODH, RES3 ;
MOVFF PRODL, RES2 ;
;

MOVF ARG1L, W
MULWF ARG2H ; ARG1L * ARG2H ->
; PRODH:PRODL

MOVF PRODL, W ;
ADDWF RES1, F ; Add cross
MOVF PRODH, W ; products
ADDWFC RES2, F ;
CLRF WREG ;
ADDWFC RES3, F ;
;

MOVF ARG1H, W ;
MULWF ARG2L ; ARG1H * ARG2L ->
; PRODH:PRODL

MOVF PRODL, W ;
ADDWF RES1, F ; Add cross
MOVF PRODH, W ; products
ADDWFC RES2, F ;
CLRF WREG ;
ADDWFC RES3, F ;

```

Example 8-4 shows the sequence to do a 16 x 16 signed multiply. Equation 8-2 shows the algorithm used. The 32-bit result is stored in four registers, RES3:RES0. To account for the sign bits of the arguments, each argument pairs' Most Significant bit (MSb) is tested and the appropriate subtractions are done.

EQUATION 8-2: 16 x 16 SIGNED MULTIPLICATION ALGORITHM

$$\begin{aligned} \text{RES3:RES0} &= \text{ARG1H:ARG1L} \cdot \text{ARG2H:ARG2L} \\ &= (\text{ARG1H} \cdot \text{ARG2H} \cdot 2^{16}) + \\ &\quad (\text{ARG1H} \cdot \text{ARG2L} \cdot 2^8) + \\ &\quad (\text{ARG1L} \cdot \text{ARG2H} \cdot 2^8) + \\ &\quad (\text{ARG1L} \cdot \text{ARG2L}) + \\ &\quad (-1 \cdot \text{ARG2H} < 7 > \cdot \text{ARG1H:ARG1L} \cdot 2^{16}) + \\ &\quad (-1 \cdot \text{ARG1H} < 7 > \cdot \text{ARG2H:ARG2L} \cdot 2^{16}) \end{aligned}$$

EXAMPLE 8-4: 16 x 16 SIGNED MULTIPLY ROUTINE

```

MOVF ARG1L, W
MULWF ARG2L ; ARG1L * ARG2L ->
; PRODH:PRODL

MOVFF PRODH, RES1 ;
MOVFF PRODL, RES0 ;
;

MOVF ARG1H, W
MULWF ARG2H ; ARG1H * ARG2H ->
; PRODH:PRODL

MOVFF PRODH, RES3 ;
MOVFF PRODL, RES2 ;
;

MOVF ARG1L, W
MULWF ARG2H ; ARG1L * ARG2H ->
; PRODH:PRODL

MOVF PRODL, W ;
ADDWF RES1, F ; Add cross
MOVF PRODH, W ; products
ADDWFC RES2, F ;
CLRF WREG ;
ADDWFC RES3, F ;
;

MOVF ARG1H, W ;
MULWF ARG2L ; ARG1H * ARG2L ->
; PRODH:PRODL

MOVF PRODL, W ;
ADDWF RES1, F ; Add cross
MOVF PRODH, W ; products
ADDWFC RES2, F ;
CLRF WREG ;
ADDWFC RES3, F ;
;

BTFS ARG2H, 7 ; ARG2H:ARG2L neg?
BRA SIGN_ARG1 ; no, check ARG1
MOVF ARG1L, W ;
SUBWF RES2 ;
MOVF ARG1H, W ;
SUBWFB RES3 ;
;

SIGN_ARG1
BTFS ARG1H, 7 ; ARG1H:ARG1L neg?
BRA CONT_CODE ; no, done
MOVF ARG2L, W ;
SUBWF RES2 ;
MOVF ARG2H, W ;
SUBWFB RES3 ;
;

CONT_CODE
:

```

9.0 INTERRUPTS

The PIC18FXX20 devices have multiple interrupt sources and an interrupt priority feature that allows each interrupt source to be assigned a high or a low priority level. The high priority interrupt vector is at 000008h, while the low priority interrupt vector is at 000018h. High priority interrupt events will override any low priority interrupts that may be in progress.

There are thirteen registers which are used to control interrupt operation. They are:

- RCON
- INTCON
- INTCON2
- INTCON3
- PIR1, PIR2, PIR3
- PIE1, PIE2, PIE3
- IPR1, IPR2, IPR3

It is recommended that the Microchip header files, supplied with MPLAB® IDE, be used for the symbolic bit names in these registers. This allows the assembler/compiler to automatically take care of the placement of these bits within the specified register.

Each interrupt source has three bits to control its operation. The functions of these bits are:

- Flag bit to indicate that an interrupt event occurred
- Enable bit that allows program execution to branch to the interrupt vector address when the flag bit is set
- Priority bit to select high priority or low priority

The interrupt priority feature is enabled by setting the IPEN bit (RCON<7>). When interrupt priority is enabled, there are two bits which enable interrupts globally. Setting the GIEH bit (INTCON<7>) enables all interrupts that have the priority bit set. Setting the GIEL bit (INTCON<6>) enables all interrupts that have the priority bit cleared. When the interrupt flag, enable bit and appropriate global interrupt enable bit are set, the interrupt will vector immediately to address 000008h or 000018h, depending on the priority level. Individual interrupts can be disabled through their corresponding enable bits.

When the IPEN bit is cleared (default state), the interrupt priority feature is disabled and interrupts are compatible with PIC® mid-range devices. In Compatibility mode, the interrupt priority bits for each source have no effect. INTCON<6> is the PEIE bit, which enables/disables all peripheral interrupt sources. INTCON<7> is the GIE bit, which enables/disables all interrupt sources. All interrupts branch to address 000008h in Compatibility mode.

When an interrupt is responded to, the Global Interrupt Enable bit is cleared to disable further interrupts. If the IPEN bit is cleared, this is the GIE bit. If interrupt priority levels are used, this will be either the GIEH or GIEL bit. High priority interrupt sources can interrupt a low priority interrupt.

The return address is pushed onto the stack and the PC is loaded with the interrupt vector address (000008h or 000018h). Once in the Interrupt Service Routine, the source(s) of the interrupt can be determined by polling the interrupt flag bits. The interrupt flag bits must be cleared in software before re-enabling interrupts to avoid recursive interrupts.

The “return from interrupt” instruction, `RETFIE`, exits the interrupt routine and sets the GIE bit (GIEH or GIEL if priority levels are used), which re-enables interrupts.

For external interrupt events, such as the INT pins or the PORTB input change interrupt, the interrupt latency will be three to four instruction cycles. The exact latency is the same for one or two-cycle instructions. Individual interrupt flag bits are set, regardless of the status of their corresponding enable bit or the GIE bit.

PIC18F6520/8520/6620/8620/6720/8720

FIGURE 9-1: INTERRUPT LOGIC

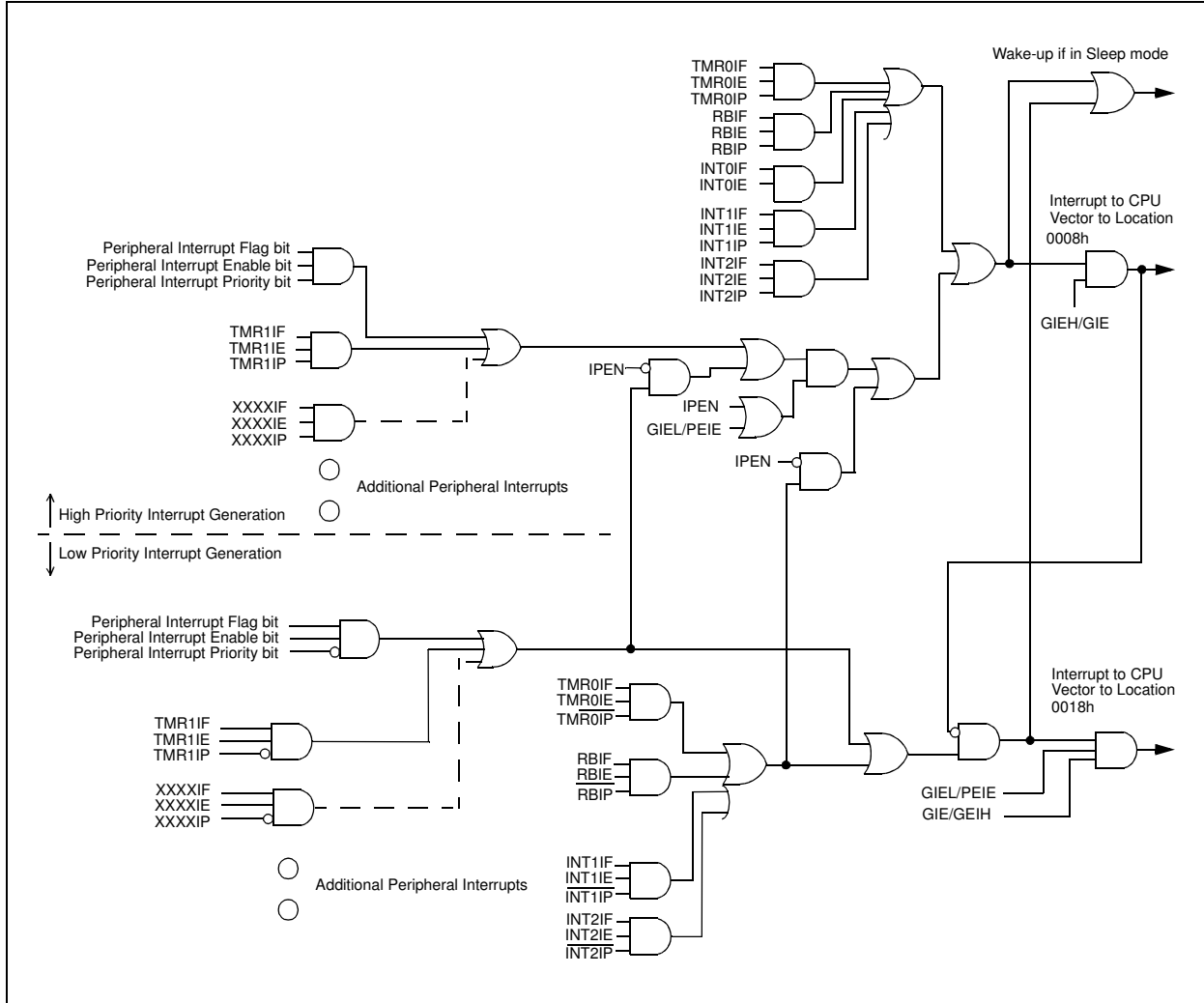

PIC18F6520/8520/6620/8620/6720/8720

9.1 INTCON Registers

The INTCON registers are readable and writable registers, which contain various enable, priority and flag bits.

Note: Interrupt flag bits are set when an interrupt condition occurs, regardless of the state of its corresponding enable bit or the global enable bit. User software should ensure the appropriate interrupt flag bits are clear prior to enabling an interrupt. This feature allows for software polling.

REGISTER 9-1: INTCON REGISTER

R/W-0	R/W-0	R/W-0	R/W-0	R/W-0	R/W-0	R/W-0	R/W-x
GIE/GIEH	PEIE/GIEL	TMR0IE	INT0IE	RBIE	TMR0IF	INT0IF	RBIF
							bit 0

- bit 7 **GIE/GIEH:** Global Interrupt Enable bit
When IPEN (RCON<7>) = 0:
 1 = Enables all unmasked interrupts
 0 = Disables all interrupts
When IPEN (RCON<7>) = 1:
 1 = Enables all high priority interrupts
 0 = Disables all interrupts
- bit 6 **PEIE/GIEL:** Peripheral Interrupt Enable bit
When IPEN (RCON<7>) = 0:
 1 = Enables all unmasked peripheral interrupts
 0 = Disables all peripheral interrupts
When IPEN (RCON<7>) = 1:
 1 = Enables all low priority peripheral interrupts
 0 = Disables all low priority peripheral interrupts
- bit 5 **TMR0IE:** TMR0 Overflow Interrupt Enable bit
 1 = Enables the TMR0 overflow interrupt
 0 = Disables the TMR0 overflow interrupt
- bit 4 **INT0IE:** INT0 External Interrupt Enable bit
 1 = Enables the INT0 external interrupt
 0 = Disables the INT0 external interrupt
- bit 3 **RBIE:** RB Port Change Interrupt Enable bit
 1 = Enables the RB port change interrupt
 0 = Disables the RB port change interrupt
- bit 2 **TMR0IF:** TMR0 Overflow Interrupt Flag bit
 1 = TMR0 register has overflowed (must be cleared in software)
 0 = TMR0 register did not overflow
- bit 1 **INT0IF:** INT0 External Interrupt Flag bit
 1 = The INT0 external interrupt occurred (must be cleared in software)
 0 = The INT0 external interrupt did not occur
- bit 0 **RBIF:** RB Port Change Interrupt Flag bit
 1 = At least one of the RB7:RB4 pins changed state (must be cleared in software)
 0 = None of the RB7:RB4 pins have changed state

Note: A mismatch condition will continue to set this bit. Reading PORTB will end the mismatch condition and allow the bit to be cleared.

Legend:

R = Readable bit	W = Writable bit	U = Unimplemented bit, read as '0'
- n = Value at POR	'1' = Bit is set	'0' = Bit is cleared x = Bit is unknown

PIC18F6520/8520/6620/8620/6720/8720

REGISTER 9-2: INTCON2 REGISTER

R/W-1	R/W-1	R/W-1	R/W-1	R/W-1	R/W-1	R/W-1	R/W-1
$\overline{\text{RBPU}}$	INTEDG0	INTEDG1	INTEDG2	INTEDG3	TMR0IP	INT3IP	RBIP
bit 7							bit 0

- bit 7 **$\overline{\text{RBPU}}$** : PORTB Pull-up Enable bit
 1 = All PORTB pull-ups are disabled
 0 = PORTB pull-ups are enabled by individual port latch values
- bit 6 **INTEDG0**: External Interrupt 0 Edge Select bit
 1 = Interrupt on rising edge
 0 = Interrupt on falling edge
- bit 5 **INTEDG1**: External Interrupt 1 Edge Select bit
 1 = Interrupt on rising edge
 0 = Interrupt on falling edge
- bit 4 **INTEDG2**: External Interrupt 2 Edge Select bit
 1 = Interrupt on rising edge
 0 = Interrupt on falling edge
- bit 3 **INTEDG3**: External Interrupt 3 Edge Select bit
 1 = Interrupt on rising edge
 0 = Interrupt on falling edge
- bit 2 **TMR0IP**: TMR0 Overflow Interrupt Priority bit
 1 = High priority
 0 = Low priority
- bit 1 **INT3IP**: INT3 External Interrupt Priority bit
 1 = High priority
 0 = Low priority
- bit 0 **RBIP**: RB Port Change Interrupt Priority bit
 1 = High priority
 0 = Low priority

Legend:

R = Readable bit W = Writable bit U = Unimplemented bit, read as '0'
 - n = Value at POR '1' = Bit is set '0' = Bit is cleared x = Bit is unknown

Note: Interrupt flag bits are set when an interrupt condition occurs, regardless of the state of its corresponding enable bit or the global enable bit. User software should ensure the appropriate interrupt flag bits are clear prior to enabling an interrupt. This feature allows for software polling.

PIC18F6520/8520/6620/8620/6720/8720

REGISTER 9-3: INTCON3 REGISTER

R/W-1	R/W-1	R/W-0	R/W-0	R/W-0	R/W-0	R/W-0	R/W-0
INT2IP	INT1IP	INT3IE	INT2IE	INT1IE	INT3IF	INT2IF	INT1IF

bit 7 bit 0

- bit 7 **INT2IP:** INT2 External Interrupt Priority bit
1 = High priority
0 = Low priority
- bit 6 **INT1IP:** INT1 External Interrupt Priority bit
1 = High priority
0 = Low priority
- bit 5 **INT3IE:** INT3 External Interrupt Enable bit
1 = Enables the INT3 external interrupt
0 = Disables the INT3 external interrupt
- bit 4 **INT2IE:** INT2 External Interrupt Enable bit
1 = Enables the INT2 external interrupt
0 = Disables the INT2 external interrupt
- bit 3 **INT1IE:** INT1 External Interrupt Enable bit
1 = Enables the INT1 external interrupt
0 = Disables the INT1 external interrupt
- bit 2 **INT3IF:** INT3 External Interrupt Flag bit
1 = The INT3 external interrupt occurred (must be cleared in software)
0 = The INT3 external interrupt did not occur
- bit 1 **INT2IF:** INT2 External Interrupt Flag bit
1 = The INT2 external interrupt occurred (must be cleared in software)
0 = The INT2 external interrupt did not occur
- bit 0 **INT1IF:** INT1 External Interrupt Flag bit
1 = The INT1 external interrupt occurred (must be cleared in software)
0 = The INT1 external interrupt did not occur

Legend:

R = Readable bit W = Writable bit U = Unimplemented bit, read as '0'
- n = Value at POR '1' = Bit is set '0' = Bit is cleared x = Bit is unknown

Note: Interrupt flag bits are set when an interrupt condition occurs, regardless of the state of its corresponding enable bit or the global enable bit. User software should ensure the appropriate interrupt flag bits are clear prior to enabling an interrupt. This feature allows for software polling.

PIC18F6520/8520/6620/8620/6720/8720

9.2 PIR Registers

The PIR registers contain the individual flag bits for the peripheral interrupts. Due to the number of peripheral interrupt sources, there are three Peripheral Interrupt Flag Registers (PIR1, PIR2 and PIR3).

Note 1: Interrupt flag bits are set when an interrupt condition occurs, regardless of the state of its corresponding enable bit or the global enable bit, GIE (INTCON<7>).

2: User software should ensure the appropriate interrupt flag bits are cleared prior to enabling an interrupt and after servicing that interrupt.

REGISTER 9-4: PIR1: PERIPHERAL INTERRUPT REQUEST (FLAG) REGISTER 1

R/W-0	R/W-0	R-0	R-0	R/W-0	R/W-0	R/W-0	R/W-0
PSPIF ⁽¹⁾	ADIF	RC1IF	TX1IF	SSPIF	CCP1IF	TMR2IF	TMR1IF
bit 7							bit 0

- bit 7 **PSPIF:** Parallel Slave Port Read/Write Interrupt Flag bit⁽¹⁾
1 = A read or a write operation has taken place (must be cleared in software)
0 = No read or write has occurred
- bit 6 **ADIF:** A/D Converter Interrupt Flag bit
1 = An A/D conversion completed (must be cleared in software)
0 = The A/D conversion is not complete
- bit 5 **RC1IF:** USART1 Receive Interrupt Flag bit
1 = The USART1 receive buffer, RCREG, is full (cleared when RCREG is read)
0 = The USART1 receive buffer is empty
- bit 4 **TX1IF:** USART Transmit Interrupt Flag bit
1 = The USART1 transmit buffer, TXREG, is empty (cleared when TXREG is written)
0 = The USART1 transmit buffer is full
- bit 3 **SSPIF:** Master Synchronous Serial Port Interrupt Flag bit
1 = The transmission/reception is complete (must be cleared in software)
0 = Waiting to transmit/receive
- bit 2 **CCP1IF:** CCP1 Interrupt Flag bit
Capture mode:
1 = A TMR1 register capture occurred (must be cleared in software)
0 = No TMR1 register capture occurred
Compare mode:
1 = A TMR1 register compare match occurred (must be cleared in software)
0 = No TMR1 register compare match occurred
PWM mode:
Unused in this mode.
- bit 1 **TMR2IF:** TMR2 to PR2 Match Interrupt Flag bit
1 = TMR2 to PR2 match occurred (must be cleared in software)
0 = No TMR2 to PR2 match occurred
- bit 0 **TMR1IF:** TMR1 Overflow Interrupt Flag bit
1 = TMR1 register overflowed (must be cleared in software)
0 = TMR1 register did not overflow

Note 1: Enabled only in Microcontroller mode for PIC18F8X20 devices.

Legend:

R = Readable bit W = Writable bit U = Unimplemented bit, read as '0'
- n = Value at POR '1' = Bit is set '0' = Bit is cleared x = Bit is unknown

PIC18F6520/8520/6620/8620/6720/8720

REGISTER 9-5: PIR2: PERIPHERAL INTERRUPT REQUEST (FLAG) REGISTER 2

U-0	R/W-0	U-0	R/W-0	R/W-0	R/W-0	R/W-0	R/W-0	
—	CMIF	—	EEIF	BCLIF	LVDIF	TMR3IF	CCP2IF	
bit 7								bit 0

- bit 7 **Unimplemented:** Read as '0'
- bit 6 **CMIF:** Comparator Interrupt Flag bit
 1 = The comparator input has changed (must be cleared in software)
 0 = The comparator input has not changed
- bit 5 **Unimplemented:** Read as '0'
- bit 4 **EEIF:** Data EEPROM/Flash Write Operation Interrupt Flag bit
 1 = The write operation is complete (must be cleared in software)
 0 = The write operation is not complete, or has not been started
- bit 3 **BCLIF:** Bus Collision Interrupt Flag bit
 1 = A bus collision occurred while the SSP module (configured in I²C Master mode) was transmitting (must be cleared in software)
 0 = No bus collision occurred
- bit 2 **LVDIF:** Low-Voltage Detect Interrupt Flag bit
 1 = A low-voltage condition occurred (must be cleared in software)
 0 = The device voltage is above the Low-Voltage Detect trip point
- bit 1 **TMR3IF:** TMR3 Overflow Interrupt Flag bit
 1 = TMR3 register overflowed (must be cleared in software)
 0 = TMR3 register did not overflow
- bit 0 **CCP2IF:** CCP2 Interrupt Flag bit
Capture mode:
 1 = A TMR1 or TMR3 register capture occurred (must be cleared in software)
 0 = No TMR1 or TMR3 register capture occurred
Compare mode:
 1 = A TMR1 or TMR3 register compare match occurred (must be cleared in software)
 0 = No TMR1 or TMR3 register compare match occurred
PWM mode:
 Unused in this mode.

Legend:

R = Readable bit	W = Writable bit	U = Unimplemented bit, read as '0'
- n = Value at POR	'1' = Bit is set	'0' = Bit is cleared x = Bit is unknown

PIC18F6520/8520/6620/8620/6720/8720

REGISTER 9-6: PIR3: PERIPHERAL INTERRUPT REQUEST (FLAG) REGISTER 3

U-0	U-0	R-0	R-0	R/W-0	R/W-0	R/W-0	R/W-0	
—	—	RC2IF	TX2IF	TMR4IF	CCP5IF	CCP4IF	CCP3IF	
bit 7								bit 0

- bit 7-6 **Unimplemented:** Read as '0'
- bit 5 **RC2IF:** USART2 Receive Interrupt Flag bit
 1 = The USART2 receive buffer, RCREG, is full (cleared when RCREG is read)
 0 = The USART2 receive buffer is empty
- bit 4 **TX2IF:** USART2 Transmit Interrupt Flag bit
 1 = The USART2 transmit buffer, TXREG, is empty (cleared when TXREG is written)
 0 = The USART2 transmit buffer is full
- bit 3 **TMR4IF:** TMR3 Overflow Interrupt Flag bit
 1 = TMR4 register overflowed (must be cleared in software)
 0 = TMR4 register did not overflow
- bit 2-0 **CCPxIF:** CCPx Interrupt Flag bit (CCP Modules 3, 4 and 5)
Capture mode:
 1 = A TMR1 or TMR3 register capture occurred (must be cleared in software)
 0 = No TMR1 or TMR3 register capture occurred
Compare mode:
 1 = A TMR1 or TMR3 register compare match occurred (must be cleared in software)
 0 = No TMR1 or TMR3 register compare match occurred
PWM mode:
 Unused in this mode.

Legend:

R = Readable bit	W = Writable bit	U = Unimplemented bit, read as '0'
- n = Value at POR	'1' = Bit is set	'0' = Bit is cleared x = Bit is unknown

PIC18F6520/8520/6620/8620/6720/8720

9.3 PIE Registers

The PIE registers contain the individual enable bits for the peripheral interrupts. Due to the number of peripheral interrupt sources, there are three Peripheral Interrupt Enable registers (PIE1, PIE2 and PIE3). When the IPEN bit (RCON<7>) is '0', the PEIE bit must be set to enable any of these peripheral interrupts.

REGISTER 9-7: PIE1: PERIPHERAL INTERRUPT ENABLE REGISTER 1

R/W-0	R/W-0	R/W-0	R/W-0	R/W-0	R/W-0	R/W-0	R/W-0
PSPIE ⁽¹⁾	ADIE	RC1IE	TX1IE	SSPIE	CCP1IE	TMR2IE	TMR1IE
bit 7							bit 0

bit 7 **PSPIE:** Parallel Slave Port Read/Write Interrupt Enable bit⁽¹⁾

1 = Enables the PSP read/write interrupt
0 = Disables the PSP read/write interrupt

bit 6 **ADIE:** A/D Converter Interrupt Enable bit

1 = Enables the A/D interrupt
0 = Disables the A/D interrupt

bit 5 **RC1IE:** USART1 Receive Interrupt Enable bit

1 = Enables the USART1 receive interrupt
0 = Disables the USART1 receive interrupt

bit 4 **TX1IE:** USART1 Transmit Interrupt Enable bit

1 = Enables the USART1 transmit interrupt
0 = Disables the USART1 transmit interrupt

bit 3 **SSPIE:** Master Synchronous Serial Port Interrupt Enable bit

1 = Enables the MSSP interrupt
0 = Disables the MSSP interrupt

bit 2 **CCP1IE:** CCP1 Interrupt Enable bit

1 = Enables the CCP1 interrupt
0 = Disables the CCP1 interrupt

bit 1 **TMR2IE:** TMR2 to PR2 Match Interrupt Enable bit

1 = Enables the TMR2 to PR2 match interrupt
0 = Disables the TMR2 to PR2 match interrupt

bit 0 **TMR1IE:** TMR1 Overflow Interrupt Enable bit

1 = Enables the TMR1 overflow interrupt
0 = Disables the TMR1 overflow interrupt

Note 1: Enabled only in Microcontroller mode for PIC18F8X20 devices.

Legend:

R = Readable bit	W = Writable bit	U = Unimplemented bit, read as '0'
- n = Value at POR	'1' = Bit is set	'0' = Bit is cleared x = Bit is unknown

PIC18F6520/8520/6620/8620/6720/8720

REGISTER 9-8: PIE2: PERIPHERAL INTERRUPT ENABLE REGISTER 2

U-0	R/W-0	U-0	R/W-0	R/W-0	R/W-0	R/W-0	R/W-0	
—	CMIE	—	EEIE	BCLIE	LVDIE	TMR3IE	CCP2IE	
bit 7								bit 0

- bit 7 **Unimplemented:** Read as '0'
- bit 6 **CMIE:** Comparator Interrupt Enable bit
1 = Enables the comparator interrupt
0 = Disables the comparator interrupt
- bit 5 **Unimplemented:** Read as '0'
- bit 4 **EEIE:** Data EEPROM/Flash Write Operation Interrupt Enable bit
1 = Enables the write operation interrupt
0 = Disables the write operation interrupt
- bit 3 **BCLIE:** Bus Collision Interrupt Enable bit
1 = Enables the bus collision interrupt
0 = Disables the bus collision interrupt
- bit 2 **LVDIE:** Low-Voltage Detect Interrupt Enable bit
1 = Enables the Low-Voltage Detect interrupt
0 = Disables the Low-Voltage Detect interrupt
- bit 1 **TMR3IE:** TMR3 Overflow Interrupt Enable bit
1 = Enables the TMR3 overflow interrupt
0 = Disables the TMR3 overflow interrupt
- bit 0 **CCP2IE:** CCP2 Interrupt Enable bit
1 = Enables the CCP2 interrupt
0 = Disables the CCP2 interrupt

Legend:

R = Readable bit	W = Writable bit	U = Unimplemented bit, read as '0'
- n = Value at POR	'1' = Bit is set	'0' = Bit is cleared x = Bit is unknown

PIC18F6520/8520/6620/8620/6720/8720

REGISTER 9-9: PIE3: PERIPHERAL INTERRUPT ENABLE REGISTER 3

U-0	U-0	R/W-0	R/W-0	R/W-0	R/W-0	R/W-0	R/W-0
—	—	RC2IE	TX2IE	TMR4IE	CCP5IE	CCP4IE	CCP3IE

bit 7 bit 0

- bit 7-6 **Unimplemented:** Read as '0'
- bit 5 **RC2IE:** USART2 Receive Interrupt Enable bit
1 = Enables the USART2 receive interrupt
0 = Disables the USART2 receive interrupt
- bit 4 **TX2IE:** USART2 Transmit Interrupt Enable bit
1 = Enables the USART2 transmit interrupt
0 = Disables the USART2 transmit interrupt
- bit 3 **TMR4IE:** TMR4 to PR4 Match Interrupt Enable bit
1 = Enables the TMR4 to PR4 match interrupt
0 = Disables the TMR4 to PR4 match interrupt
- bit 2-0 **CCPxIE:** CCPx Interrupt Enable bit (CCP Modules 3, 4 and 5)
1 = Enables the CCPx interrupt
0 = Disables the CCPx interrupt

Legend:

R = Readable bit	W = Writable bit	U = Unimplemented bit, read as '0'
- n = Value at POR	'1' = Bit is set	'0' = Bit is cleared x = Bit is unknown

PIC18F6520/8520/6620/8620/6720/8720

9.4 IPR Registers

The IPR registers contain the individual priority bits for the peripheral interrupts. Due to the number of peripheral interrupt sources, there are three Peripheral Interrupt Priority Registers (IPR1, IPR2 and IPR3). The operation of the priority bits requires that the Interrupt Priority Enable (IPEN) bit be set.

REGISTER 9-10: IPR1: PERIPHERAL INTERRUPT PRIORITY REGISTER 1

R/W-1	R/W-1	R/W-1	R/W-1	R/W-1	R/W-1	R/W-1	R/W-1
PSPIP ⁽¹⁾	ADIP	RC1IP	TX1IP	SSPIP	CCP1IP	TMR2IP	TMR1IP
bit 7							bit 0

- bit 7 **PSPIP:** Parallel Slave Port Read/Write Interrupt Priority bit⁽¹⁾
1 = High priority
0 = Low priority
- bit 6 **ADIP:** A/D Converter Interrupt Priority bit
1 = High priority
0 = Low priority
- bit 5 **RC1IP:** USART1 Receive Interrupt Priority bit
1 = High priority
0 = Low priority
- bit 4 **TX1IP:** USART1 Transmit Interrupt Priority bit
1 = High priority
0 = Low priority
- bit 3 **SSPIP:** Master Synchronous Serial Port Interrupt Priority bit
1 = High priority
0 = Low priority
- bit 2 **CCP1IP:** CCP1 Interrupt Priority bit
1 = High priority
0 = Low priority
- bit 1 **TMR2IP:** TMR2 to PR2 Match Interrupt Priority bit
1 = High priority
0 = Low priority
- bit 0 **TMR1IP:** TMR1 Overflow Interrupt Priority bit
1 = High priority
0 = Low priority

Note 1: Enabled only in Microcontroller mode for PIC18F8X20 devices.

Legend:			
R = Readable bit	W = Writable bit	U = Unimplemented bit, read as '0'	
- n = Value at POR	'1' = Bit is set	'0' = Bit is cleared	x = Bit is unknown

PIC18F6520/8520/6620/8620/6720/8720

REGISTER 9-11: IPR2: PERIPHERAL INTERRUPT PRIORITY REGISTER 2

U-0	R/W-1	U-0	R/W-1	R/W-1	R/W-1	R/W-1	R/W-1	
—	CMIP	—	EEIP	BCLIP	LVDIP	TMR3IP	CCP2IP	
bit 7								bit 0

- bit 7 **Unimplemented:** Read as '0'
- bit 6 **CMIP:** Comparator Interrupt Priority bit
1 = High priority
0 = Low priority
- bit 5 **Unimplemented:** Read as '0'
- bit 4 **EEIP:** Data EEPROM/Flash Write Operation Interrupt Priority bit
1 = High priority
0 = Low priority
- bit 3 **BCLIP:** Bus Collision Interrupt Priority bit
1 = High priority
0 = Low priority
- bit 2 **LVDIP:** Low-Voltage Detect Interrupt Priority bit
1 = High priority
0 = Low priority
- bit 1 **TMR3IP:** TMR3 Overflow Interrupt Priority bit
1 = High priority
0 = Low priority
- bit 0 **CCP2IP:** CCP2 Interrupt Priority bit
1 = High priority
0 = Low priority

Legend:			
R = Readable bit	W = Writable bit	U = Unimplemented bit, read as '0'	
- n = Value at POR	'1' = Bit is set	'0' = Bit is cleared	x = Bit is unknown

PIC18F6520/8520/6620/8620/6720/8720

REGISTER 9-12: IPR3: PERIPHERAL INTERRUPT PRIORITY REGISTER 3

U-0	U-0	R/W-1	R/W-1	R/W-1	R/W-1	R/W-1	R/W-1
—	—	RC2IP	TX2IP	TMR4IP	CCP5IP	CCP4IP	CCP3IP

bit 7 bit 0

- bit 7-6 **Unimplemented:** Read as '0'
- bit 5 **RC2IP:** USART2 Receive Interrupt Priority bit
1 = High priority
0 = Low priority
- bit 4 **TX2IP:** USART2 Transmit Interrupt Priority bit
1 = High priority
0 = Low priority
- bit 3 **TMR4IP:** TMR4 to PR4 Match Interrupt Priority bit
1 = High priority
0 = Low priority
- bit 2-0 **CCPxIP:** CCPx Interrupt Priority bit (CCP Modules 3, 4 and 5)
1 = High priority
0 = Low priority

Legend:

R = Readable bit	W = Writable bit	U = Unimplemented bit, read as '0'
- n = Value at POR	'1' = Bit is set	'0' = Bit is cleared x = Bit is unknown

PIC18F6520/8520/6620/8620/6720/8720

9.5 RCON Register

The RCON register contains the IPEN bit, which is used to enable prioritized interrupts. The functions of the other bits in this register are discussed in more detail in **Section 4.14 “RCON Register”**.

REGISTER 9-13: RCON REGISTER

R/W-0	U-0	U-0	R/W-1	R-1	R-1	R/W-0	R/W-0	
IPEN	—	—	\overline{RI}	\overline{TO}	\overline{PD}	\overline{POR}	\overline{BOR}	
bit 7								bit 0

- bit 7 **IPEN:** Interrupt Priority Enable bit
1 = Enable priority levels on interrupts
0 = Disable priority levels on interrupts (PIC16 Compatibility mode)
- bit 6-5 **Unimplemented:** Read as '0'
- bit 4 **\overline{RI} :** RESET Instruction Flag bit
For details of bit operation, see Register 4-4.
- bit 3 **\overline{TO} :** Watchdog Time-out Flag bit
For details of bit operation, see Register 4-4.
- bit 2 **\overline{PD} :** Power-Down Detection Flag bit
For details of bit operation, see Register 4-4.
- bit 1 **\overline{POR} :** Power-on Reset Status bit
For details of bit operation, see Register 4-4.
- bit 0 **\overline{BOR} :** Brown-out Reset Status bit
For details of bit operation, see Register 4-4.

Legend:

R = Readable bit	W = Writable bit	U = Unimplemented bit, read as '0'
- n = Value at POR	'1' = Bit is set	'0' = Bit is cleared x = Bit is unknown

PIC18F6520/8520/6620/8620/6720/8720

9.6 INT0 Interrupt

External interrupts on the RB0/INT0, RB1/INT1, RB2/INT2 and RB3/INT3 pins are edge-triggered: either rising, if the corresponding INTEDGx bit is set in the INTCON2 register, or falling, if the INTEDGx bit is clear. When a valid edge appears on the RBx/INTx pin, the corresponding flag bit, INTxF, is set. This interrupt can be disabled by clearing the corresponding enable bit, INTxE. Flag bit, INTxF, must be cleared in software in the Interrupt Service Routine before re-enabling the interrupt. All external interrupts (INT0, INT1, INT2 and INT3) can wake-up the processor from Sleep if bit INTxIE was set prior to going into Sleep. If the Global Interrupt Enable bit, GIE, is set, the processor will branch to the interrupt vector following wake-up.

The interrupt priority for INT, INT2 and INT3 is determined by the value contained in the interrupt priority bits: INT1IP (INTCON3<6>), INT2IP (INTCON3<7>) and INT3IP (INTCON2<1>). There is no priority bit associated with INT0; it is always a high priority interrupt source.

9.7 TMR0 Interrupt

In 8-bit mode (which is the default), an overflow in the TMR0 register (FFh → 00h) will set flag bit TMR0IF. In 16-bit mode, an overflow in the TMR0H:TMR0L registers (FFFFh → 0000h) will set flag bit TMR0IF. The interrupt can be enabled/disabled by setting/clearing enable bit, TMR0IE (INTCON<5>). Interrupt priority for Timer0 is determined by the value contained in the interrupt priority bit, TMR0IP (INTCON2<2>). See **Section 11.0 “Timer0 Module”** for further details on the Timer0 module.

9.8 PORTB Interrupt-on-Change

An input change on PORTB<7:4> sets flag bit, RBIF (INTCON<0>). The interrupt can be enabled/disabled by setting/clearing enable bit, RBIE (INTCON<3>). Interrupt priority for PORTB interrupt-on-change is determined by the value contained in the interrupt priority bit, RBIP (INTCON2<0>).

9.9 Context Saving During Interrupts

During an interrupt, the return PC value is saved on the stack. Additionally, the WREG, Status and BSR registers are saved on the fast return stack. If a fast return from interrupt is not used (see **Section 4.3 “Fast Register Stack”**), the user may need to save the WREG, Status and BSR registers in software. Depending on the user’s application, other registers may also need to be saved. Example 9-1 saves and restores the WREG, Status and BSR registers during an Interrupt Service Routine.

EXAMPLE 9-1: SAVING STATUS, WREG AND BSR REGISTERS IN RAM

```
MOVWF  W_TEMP                ; W_TEMP is in virtual bank
MOVFF  STATUS, STATUS_TEMP   ; STATUS_TEMP located anywhere
MOVFF  BSR, BSR_TEMP         ; BSR located anywhere
;
; USER ISR CODE
;
MOVFF  BSR_TEMP, BSR         ; Restore BSR
MOVF   W_TEMP, W             ; Restore WREG
MOVFF  STATUS_TEMP, STATUS   ; Restore STATUS
```

PIC18F6520/8520/6620/8620/6720/8720

10.0 I/O PORTS

Depending on the device selected, there are either seven or nine I/O ports available on PIC18FXX20 devices. Some of their pins are multiplexed with one or more alternate functions from the other peripheral features on the device. In general, when a peripheral is enabled, that pin may not be used as a general purpose I/O pin.

Each port has three registers for its operation. These registers are:

- TRIS register (data direction register)
- PORT register (reads the levels on the pins of the device)
- LAT register (output latch)

The Data Latch (LAT register) is useful for read-modify-write operations on the value that the I/O pins are driving.

A simplified version of a generic I/O port and its operation is shown in Figure 10-1.

FIGURE 10-1: SIMPLIFIED BLOCK DIAGRAM OF PORT/LAT/TRIS OPERATION

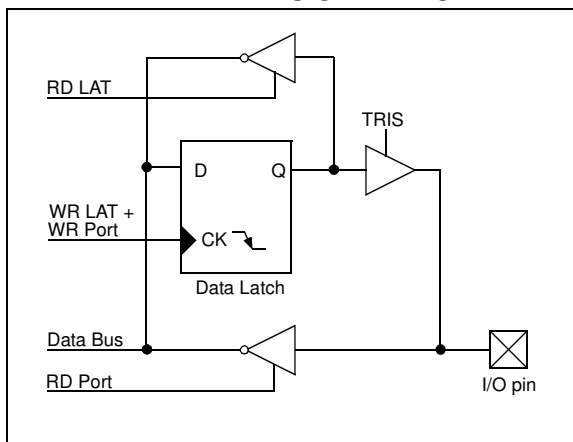

10.1 PORTA, TRISA and LATA Registers

PORTA is a 7-bit wide, bidirectional port. The corresponding data direction register is TRISA. Setting a TRISA bit (= 1) will make the corresponding PORTA pin an input (i.e., put the corresponding output driver in a high-impedance mode). Clearing a TRISA bit (= 0) will make the corresponding PORTA pin an output (i.e., put the contents of the output latch on the selected pin).

Reading the PORTA register reads the status of the pins, whereas writing to it will write to the port latch.

The Data Latch register (LATA) is also memory mapped. Read-modify-write operations on the LATA register, read and write the latched output value for PORTA.

The RA4 pin is multiplexed with the Timer0 module clock input to become the RA4/T0CKI pin. The RA4/T0CKI pin is a Schmitt Trigger input and an open-drain output. All other RA port pins have TTL input levels and full CMOS output drivers.

The RA6 pin is only enabled as a general I/O pin in ECIO and RCIO Oscillator modes.

The other PORTA pins are multiplexed with analog inputs and the analog VREF+ and VREF- inputs. The operation of each pin is selected by clearing/setting the control bits in the ADCON1 register (A/D Control Register 1).

Note: On a Power-on Reset, RA5 and RA3:RA0 are configured as analog inputs and read as '0'. RA6 and RA4 are configured as digital inputs.

The TRISA register controls the direction of the RA pins, even when they are being used as analog inputs. The user must ensure the bits in the TRISA register are maintained set when using them as analog inputs.

EXAMPLE 10-1: INITIALIZING PORTA

```
CLRF   PORTA   ; Initialize PORTA by
               ; clearing output
               ; data latches
CLRF   LATA    ; Alternate method
               ; to clear output
               ; data latches
MOVLW  0x0F   ; Configure A/D
MOVWF  ADCON1 ; for digital inputs
MOVLW  0xCF   ; Value used to
               ; initialize data
               ; direction
MOVWF  TRISA  ; Set RA<3:0> as inputs
               ; RA<5:4> as outputs
```

PIC18F6520/8520/6620/8620/6720/8720

FIGURE 10-2: BLOCK DIAGRAM OF RA3:RA0 AND RA5 PINS

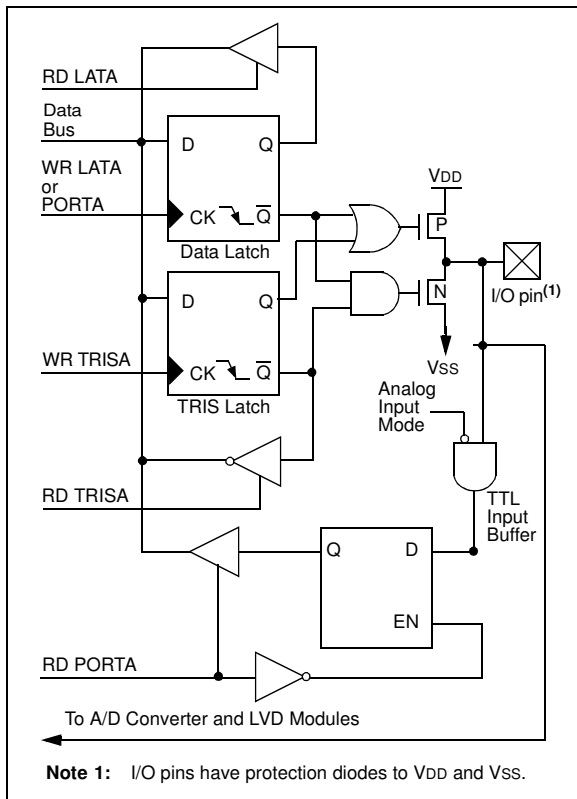

FIGURE 10-3: BLOCK DIAGRAM OF RA4/T0CKI PIN

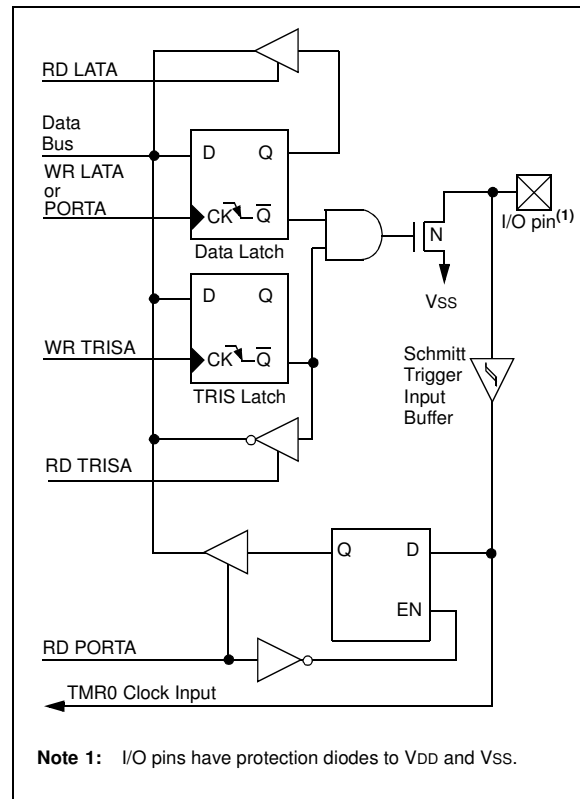
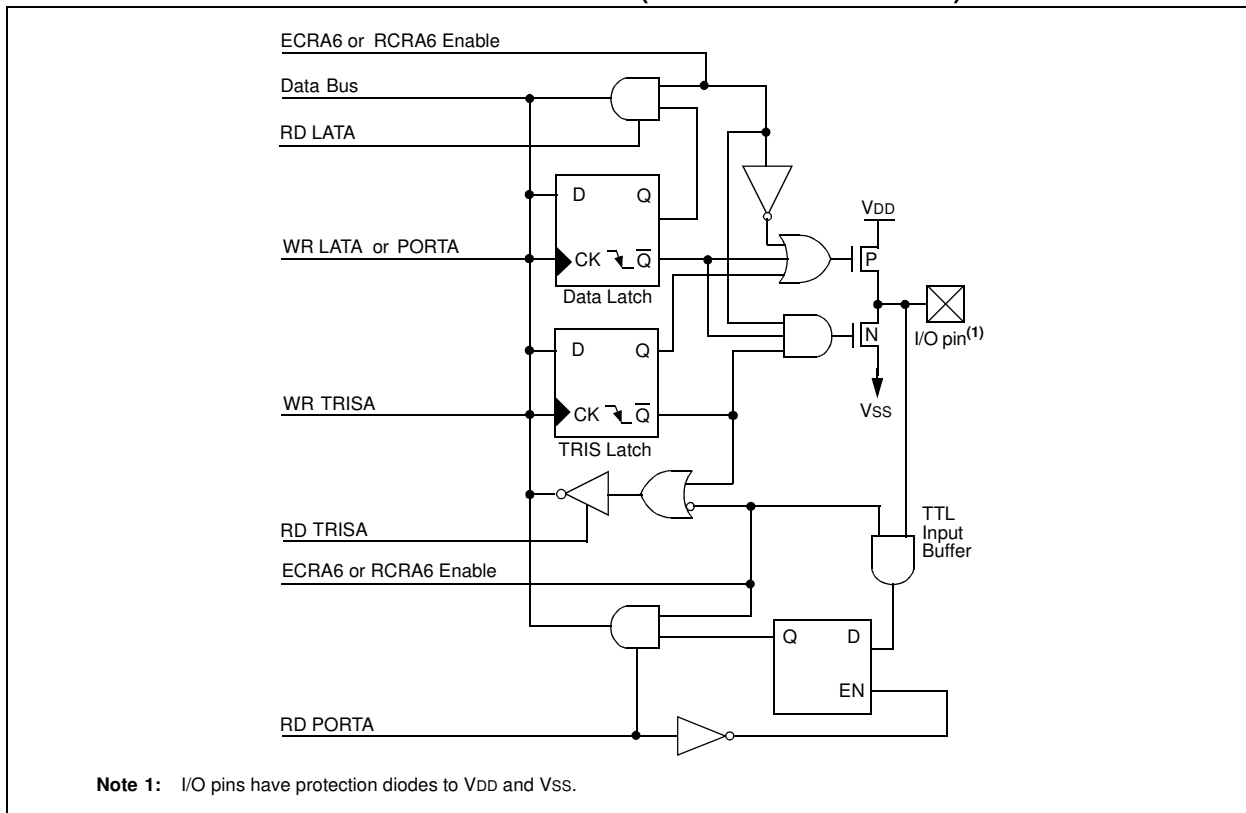

FIGURE 10-4: BLOCK DIAGRAM OF RA6 PIN (WHEN ENABLED AS I/O)



PIC18F6520/8520/6620/8620/6720/8720

TABLE 10-1: PORTA FUNCTIONS

Name	Bit#	Buffer	Function
RA0/AN0	bit 0	TTL	Input/output or analog input.
RA1/AN1	bit 1	TTL	Input/output or analog input.
RA2/AN2/VREF-	bit 2	TTL	Input/output or analog input or VREF-.
RA3/AN3/VREF+	bit 3	TTL	Input/output or analog input or VREF+.
RA4/T0CKI	bit 4	ST	Input/output or external clock input for Timer0. Output is open-drain type.
RA5/AN4/LVDIN	bit 5	TTL	Input/output or slave select input for synchronous serial port or analog input, or Low-Voltage Detect input.
OSC2/CLKO/RA6	bit 6	TTL	OSC2 or clock output, or I/O pin.

Legend: TTL = TTL input, ST = Schmitt Trigger input

TABLE 10-2: SUMMARY OF REGISTERS ASSOCIATED WITH PORTA

Name	Bit 7	Bit 6	Bit 5	Bit 4	Bit 3	Bit 2	Bit 1	Bit 0	Value on POR, BOR	Value on all other Resets
PORTA	—	RA6	RA5	RA4	RA3	RA2	RA1	RA0	-x0x 0000	-u0u 0000
LATA	—	LATA Data Output Register							-xxx xxxx	-uuu uuuu
TRISA	—	PORTA Data Direction Register							-111 1111	-111 1111
ADCON1	—	—	VCFG1	VCFG0	PCFG3	PCFG2	PCFG1	PCFG0	--00 0000	--00 0000

Legend: x = unknown, u = unchanged, - = unimplemented locations read as '0'.
Shaded cells are not used by PORTA.

PIC18F6520/8520/6620/8620/6720/8720

10.2 PORTB, TRISB and LATB Registers

PORTB is an 8-bit wide, bidirectional port. The corresponding data direction register is TRISB. Setting a TRISB bit (= 1) will make the corresponding PORTB pin an input (i.e., put the corresponding output driver in a high-impedance mode). Clearing a TRISB bit (= 0) will make the corresponding PORTB pin an output (i.e., put the contents of the output latch on the selected pin).

The Data Latch register (LATB) is also memory mapped. Read-modify-write operations on the LATB register, read and write the latched output value for PORTB.

EXAMPLE 10-2: INITIALIZING PORTB

```

CLRF  PORTB  ; Initialize PORTB by
           ; clearing output
           ; data latches
CLRF  LATB   ; Alternate method
           ; to clear output
           ; data latches
MOVLW 0xCF  ; Value used to
           ; initialize data
           ; direction
MOVWF TRISB ; Set RB<3:0> as inputs
           ; RB<5:4> as outputs
           ; RB<7:6> as inputs
    
```

Each of the PORTB pins has a weak internal pull-up. A single control bit can turn on all the pull-ups. This is performed by clearing bit $\overline{\text{RBPU}}$ (INTCON2<7>). The weak pull-up is automatically turned off when the port pin is configured as an output. The pull-ups are disabled on a Power-on Reset.

Note: On a Power-on Reset, these pins are configured as digital inputs.

Four of the PORTB pins (RB3:RB0) are the external interrupt pins, INT3 through INT0. In order to use these pins as external interrupts, the corresponding TRISB bit must be set to '1'.

The other four PORTB pins (RB7:RB4) have an interrupt-on-change feature. Only pins configured as inputs can cause this interrupt to occur (i.e., any RB7:RB4 pin configured as an output is excluded from the interrupt-on-change comparison). The input pins (of RB7:RB4) are compared with the old value latched on the last read of PORTB. The "mismatch" outputs of RB7:RB4 are OR'ed together to generate the RB Port Change Interrupt with Flag bit, RBIF (INTCON<0>).

This interrupt can wake the device from Sleep. The user, in the Interrupt Service Routine, can clear the interrupt in the following manner:

- a) Any read or write of PORTB (except with the MOVFF instruction). This will end the mismatch condition.
- b) Clear flag bit RBIF.

A mismatch condition will continue to set flag bit, RBIF. Reading PORTB will end the mismatch condition and allow flag bit RBIF to be cleared.

The interrupt-on-change feature is recommended for wake-up on key depression operation and operations where PORTB is only used for the interrupt-on-change feature. Polling of PORTB is not recommended while using the interrupt-on-change feature.

RB3 can be configured by the configuration bit CCP2MX, as the alternate peripheral pin for the CCP2 module. This is only available when the device is configured in Microprocessor, Microprocessor with Boot Block, or Extended Microcontroller operating modes.

The RB5 pin is used as the LVP programming pin. When the LVP configuration bit is programmed, this pin loses the I/O function and become a programming test function.

Note: When LVP is enabled, the weak pull-up on RB5 is disabled.

FIGURE 10-5: BLOCK DIAGRAM OF RB7:RB4 PINS

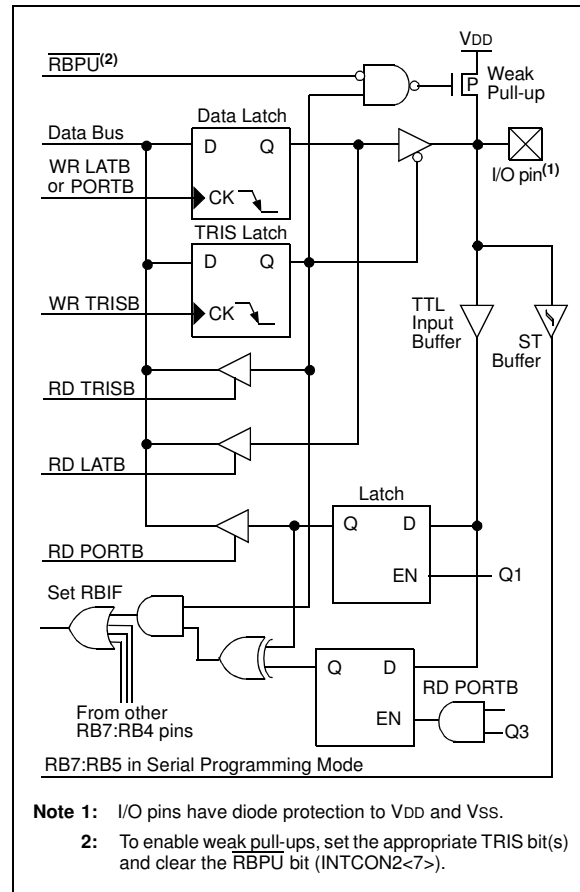

- Note 1:** I/O pins have diode protection to VDD and VSS.
- Note 2:** To enable weak pull-ups, set the appropriate TRIS bit(s) and clear the $\overline{\text{RBPU}}$ bit (INTCON2<7>).

PIC18F6520/8520/6620/8620/6720/8720

FIGURE 10-6: BLOCK DIAGRAM OF RB2:RB0 PINS

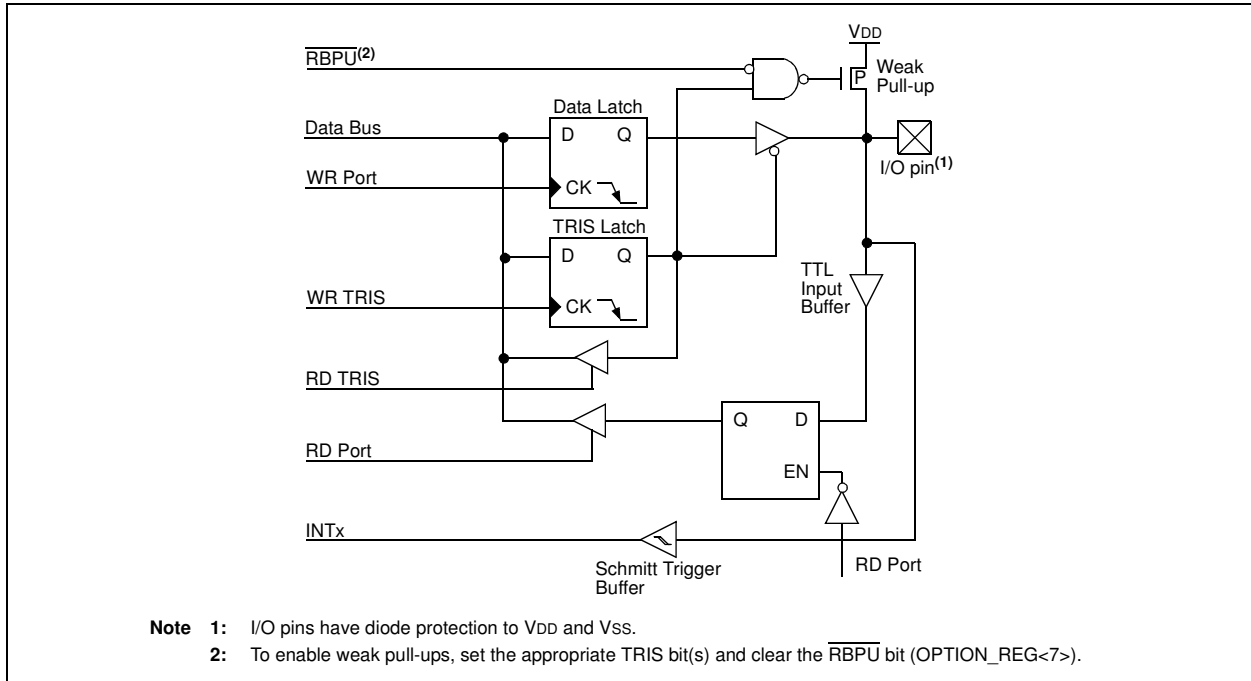
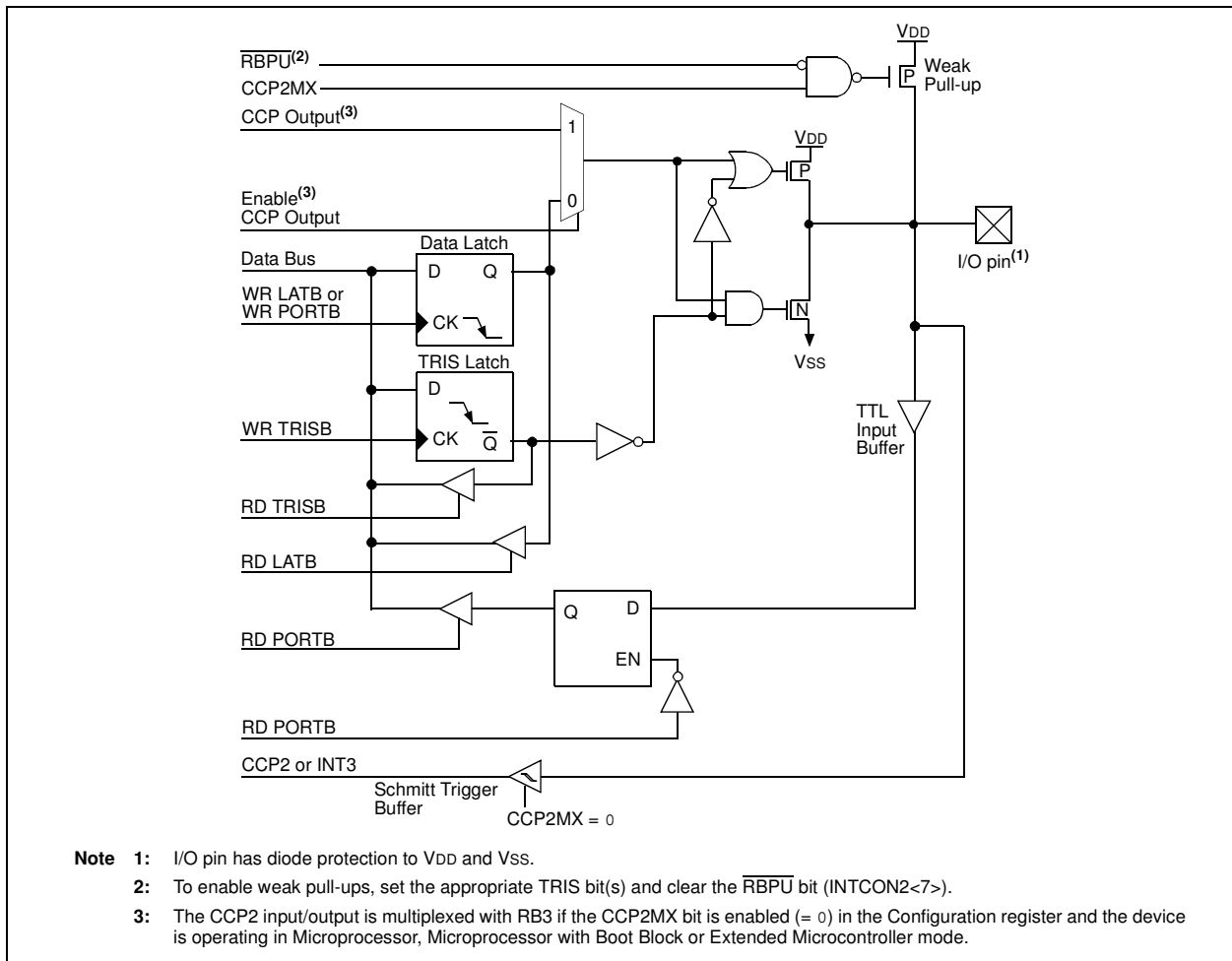

FIGURE 10-7: BLOCK DIAGRAM OF RB3 PIN



PIC18F6520/8520/6620/8620/6720/8720

TABLE 10-3: PORTB FUNCTIONS

Name	Bit#	Buffer	Function
RB0/INT0	bit 0	TTL/ST ⁽¹⁾	Input/output pin or external interrupt input 0. Internal software programmable weak pull-up.
RB1/INT1	bit 1	TTL/ST ⁽¹⁾	Input/output pin or external interrupt input 1. Internal software programmable weak pull-up.
RB2/INT2	bit 2	TTL/ST ⁽¹⁾	Input/output pin or external interrupt input 2. Internal software programmable weak pull-up.
RB3/INT3/CCP2 ⁽³⁾	bit 3	TTL/ST ⁽⁴⁾	Input/output pin or external interrupt input 3. Capture2 input/Compare2 output/PWM output (when CCP2MX configuration bit is enabled, all PIC18F8X20 operating modes except Microcontroller mode). Internal software programmable weak pull-up.
RB4/KBI0	bit 4	TTL	Input/output pin (with interrupt-on-change). Internal software programmable weak pull-up.
RB5/KBI1/PGM	bit 5	TTL/ST ⁽²⁾	Input/output pin (with interrupt-on-change). Internal software programmable weak pull-up. Low-voltage ICSP enable pin.
RB6/KBI2/PGC	bit 6	TTL/ST ⁽²⁾	Input/output pin (with interrupt-on-change). Internal software programmable weak pull-up. Serial programming clock.
RB7/KBI3/PGD	bit 7	TTL/ST ⁽²⁾	Input/output pin (with interrupt-on-change). Internal software programmable weak pull-up. Serial programming data.

Legend: TTL = TTL input, ST = Schmitt Trigger input

Note 1: This buffer is a Schmitt Trigger input when configured as the external interrupt.

2: This buffer is a Schmitt Trigger input when used in Serial Programming mode.

3: RC1 is the alternate assignment for CCP2 when CCP2MX is not set (all operating modes except Microcontroller mode).

4: This buffer is a Schmitt Trigger input when configured as the CCP2 input.

TABLE 10-4: SUMMARY OF REGISTERS ASSOCIATED WITH PORTB

Name	Bit 7	Bit 6	Bit 5	Bit 4	Bit 3	Bit 2	Bit 1	Bit 0	Value on POR, BOR	Value on all other Resets
PORTB	RB7	RB6	RB5	RB4	RB3	RB2	RB1	RB0	xxxx xxxx	uuuu uuuu
LATB	LATB Data Output Register								xxxx xxxx	uuuu uuuu
TRISB	PORTB Data Direction Register								1111 1111	1111 1111
INTCON	GIE/GIEH	PEIE/GIEL	TMR0IE	INT0IE	RBIE	TMR0IF	INT0IF	RBIF	0000 0000	0000 0000
INTCON2	RBPU	INTEDG0	INTEDG1	INTEDG2	INTEDG3	TMR0IP	INT3IP	RBIP	1111 1111	1111 1111
INTCON3	INT2IP	INT1IP	INT3IE	INT2IE	INT1IE	INT3IF	INT2IF	INT1IF	1100 0000	1100 0000

Legend: x = unknown, u = unchanged. Shaded cells are not used by PORTB.

PIC18F6520/8520/6620/8620/6720/8720

10.3 PORTC, TRISC and LATC Registers

PORTC is an 8-bit wide, bidirectional port. The corresponding data direction register is TRISC. Setting a TRISC bit (= 1) will make the corresponding PORTC pin an input (i.e., put the corresponding output driver in a high-impedance mode). Clearing a TRISC bit (= 0) will make the corresponding PORTC pin an output (i.e., put the contents of the output latch on the selected pin).

The Data Latch register (LATC) is also memory mapped. Read-modify-write operations on the LATC register, read and write the latched output value for PORTC.

PORTC is multiplexed with several peripheral functions (Table 10-5). PORTC pins have Schmitt Trigger input buffers.

When enabling peripheral functions, care should be taken in defining TRIS bits for each PORTC pin. Some peripherals override the TRIS bit to make a pin an output, while other peripherals override the TRIS bit to make a pin an input. The user should refer to the corresponding peripheral section for the correct TRIS bit settings.

Note: On a Power-on Reset, these pins are configured as digital inputs.

The pin override value is not loaded into the TRIS register. This allows read-modify-write of the TRIS register, without concern due to peripheral overrides.

RC1 is normally configured by configuration bit, CCP2MX, as the default peripheral pin of the CCP2 module (default/erased state, CCP2MX = 1).

EXAMPLE 10-3: INITIALIZING PORTC

```
CLRF   PORTC   ; Initialize PORTC by
              ; clearing output
              ; data latches
CLRF   LATC    ; Alternate method
              ; to clear output
              ; data latches
MOVLW  0xCF   ; Value used to
              ; initialize data
              ; direction
MOVWF  TRISC   ; Set RC<3:0> as inputs
              ; RC<5:4> as outputs
              ; RC<7:6> as inputs
```

FIGURE 10-8: PORTC BLOCK DIAGRAM (PERIPHERAL OUTPUT OVERRIDE)

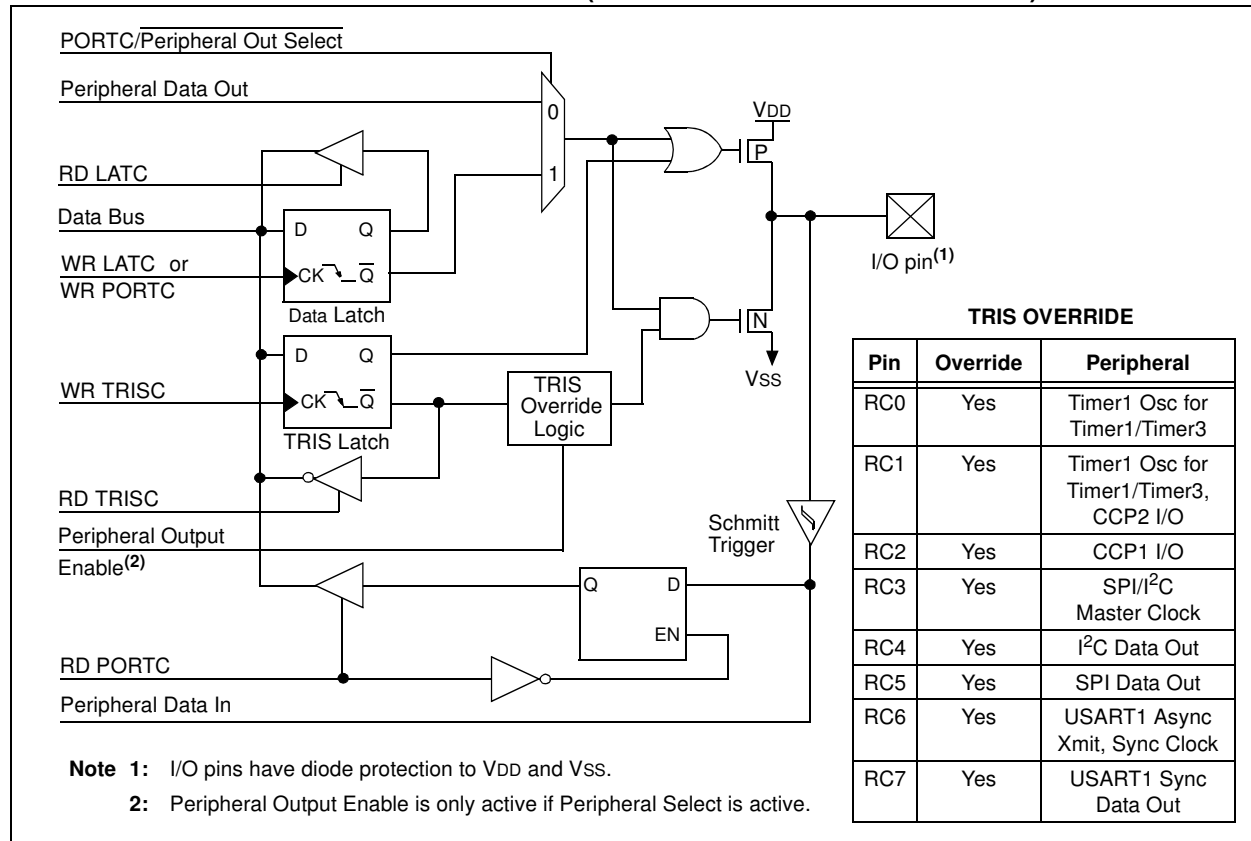

PIC18F6520/8520/6620/8620/6720/8720

TABLE 10-5: PORTC FUNCTIONS

Name	Bit#	Buffer Type	Function
RC0/T1OSO/T13CKI	bit 0	ST	Input/output port pin, Timer1 oscillator output or Timer1/Timer3 clock input.
RC1/T1OSI/CCP2 ⁽¹⁾	bit 1	ST	Input/output port pin, Timer1 oscillator input or Capture2 input/Compare2 output/PWM output (when CCP2MX configuration bit is disabled).
RC2/CCP1	bit 2	ST	Input/output port pin or Capture1 input/Compare1 output/PWM1 output.
RC3/SCK/SCL	bit 3	ST	RC3 can also be the synchronous serial clock for both SPI and I ² C modes.
RC4/SDI/SDA	bit 4	ST	RC4 can also be the SPI data in (SPI mode) or data I/O (I ² C mode).
RC5/SDO	bit 5	ST	Input/output port pin or synchronous serial port data output.
RC6/TX1/CK1	bit 6	ST	Input/output port pin, addressable USART1 asynchronous transmit or addressable USART1 synchronous clock.
RC7/RX1/DT1	bit 7	ST	Input/output port pin, addressable USART1 asynchronous receive or addressable USART1 synchronous data.

Legend: ST = Schmitt Trigger input

Note 1: RB3 is the alternate assignment for CCP2 when CCP2MX is set.

TABLE 10-6: SUMMARY OF REGISTERS ASSOCIATED WITH PORTC

Name	Bit 7	Bit 6	Bit 5	Bit 4	Bit 3	Bit 2	Bit 1	Bit 0	Value on POR, BOR	Value on all other Resets
PORTC	RC7	RC6	RC5	RC4	RC3	RC2	RC1	RC0	xxxx xxxx	uuuu uuuu
LATC	LATC Data Output Register								xxxx xxxx	uuuu uuuu
TRISC	PORTC Data Direction Register								1111 1111	1111 1111

Legend: x = unknown, u = unchanged

PIC18F6520/8520/6620/8620/6720/8720

10.4 PORTD, TRISD and LATD Registers

PORTD is an 8-bit wide, bidirectional port. The corresponding data direction register is TRISD. Setting a TRISD bit (= 1) will make the corresponding PORTD pin an input (i.e., put the corresponding output driver in a high-impedance mode). Clearing a TRISD bit (= 0) will make the corresponding PORTD pin an output (i.e., put the contents of the output latch on the selected pin).

The Data Latch register (LATD) is also memory mapped. Read-modify-write operations on the LATD register, read and write the latched output value for PORTD.

PORTD is an 8-bit port with Schmitt Trigger input buffers. Each pin is individually configurable as an input or output.

Note: On a Power-on Reset, these pins are configured as digital inputs.

PORTD is multiplexed with the system bus as the external memory interface; I/O port functions are only available when the system bus is disabled, by setting the EBDIS bit in the MEMCOM register (MEMCON<7>). When operating as the external memory interface, PORTD is the low-order byte of the multiplexed address/data bus (AD7:AD0).

PORTD can also be configured as an 8-bit wide micro-processor port (Parallel Slave Port) by setting control bit PSPMODE (TRISE<4>). In this mode, the input buffers are TTL. See **Section 10.10 "Parallel Slave Port"** for additional information on the Parallel Slave Port (PSP).

EXAMPLE 10-4: INITIALIZING PORTD

```
CLRF   PORTD   ; Initialize PORTD by
               ; clearing output
               ; data latches
CLRF   LATD    ; Alternate method
               ; to clear output
               ; data latches
MOVLW  0xCF   ; Value used to
               ; initialize data
               ; direction
MOVWF  TRISD   ; Set RD<3:0> as inputs
               ; RD<5:4> as outputs
               ; RD<7:6> as inputs
```

FIGURE 10-9: PORTD BLOCK DIAGRAM IN I/O PORT MODE

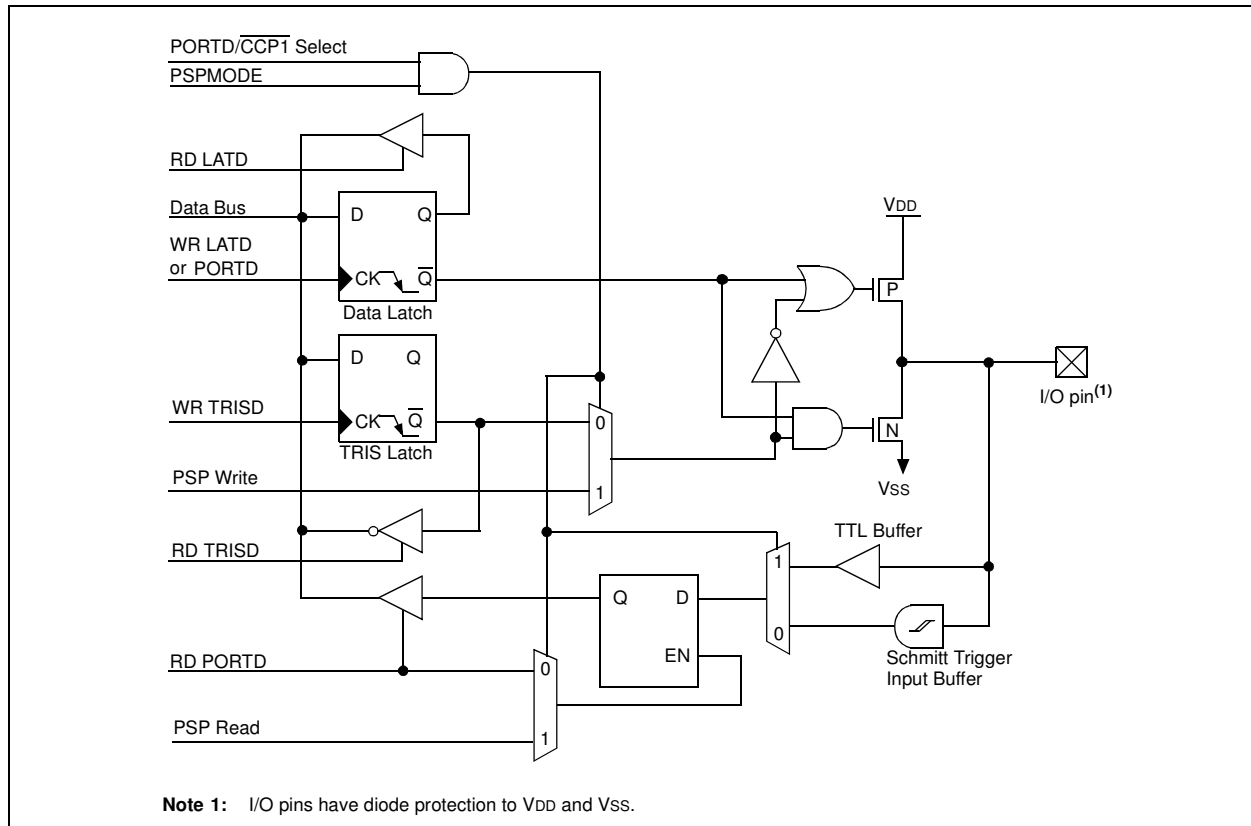

PIC18F6520/8520/6620/8620/6720/8720

FIGURE 10-10: PORTD BLOCK DIAGRAM IN SYSTEM BUS MODE

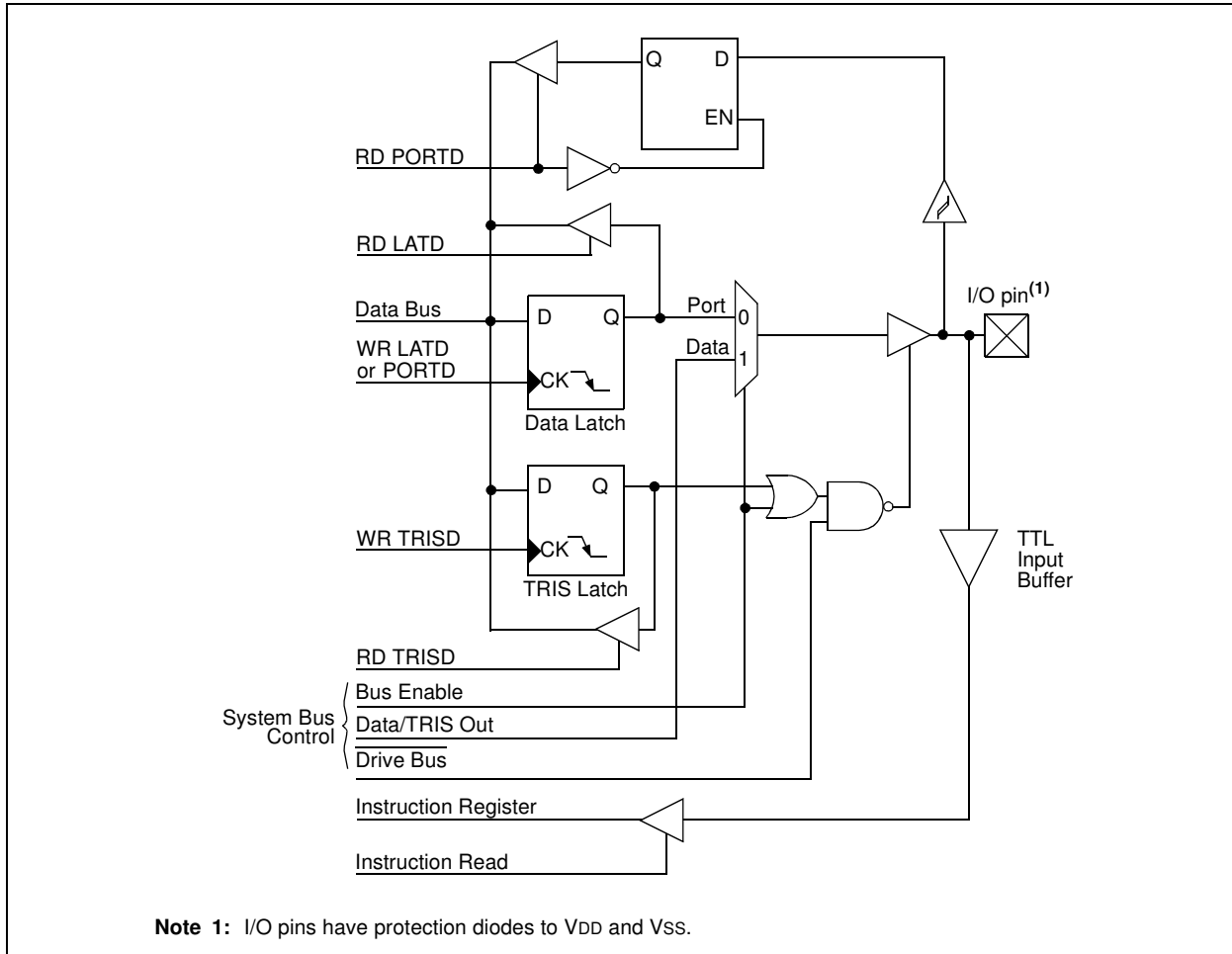

PIC18F6520/8520/6620/8620/6720/8720

TABLE 10-7: PORTD FUNCTIONS

Name	Bit#	Buffer Type	Function
RD0/PSP0/AD0	bit 0	ST/TTL ⁽¹⁾	Input/output port pin, Parallel Slave Port bit 0 or address/data bus bit 0.
RD1/PSP1/AD1	bit 1	ST/TTL ⁽¹⁾	Input/output port pin, Parallel Slave Port bit 1 or address/data bus bit 1.
RD2/PSP2/AD2	bit 2	ST/TTL ⁽¹⁾	Input/output port pin, Parallel Slave Port bit 2 or address/data bus bit 2.
RD3/PSP3/AD3	bit 3	ST/TTL ⁽¹⁾	Input/output port pin, Parallel Slave Port bit 3 or address/data bus bit 3.
RD4/PSP4/AD4	bit 4	ST/TTL ⁽¹⁾	Input/output port pin, Parallel Slave Port bit 4 or address/data bus bit 4.
RD5/PSP5/AD5	bit 5	ST/TTL ⁽¹⁾	Input/output port pin, Parallel Slave Port bit 5 or address/data bus bit 5.
RD6/PSP6/AD6	bit 6	ST/TTL ⁽¹⁾	Input/output port pin, Parallel Slave Port bit 6 or address/data bus bit 6.
RD7/PSP7/AD7	bit 7	ST/TTL ⁽¹⁾	Input/output port pin, Parallel Slave Port bit 7 or address/data bus bit 7.

Legend: ST = Schmitt Trigger input, TTL = TTL input

Note 1: Input buffers are Schmitt Triggers when in I/O mode and TTL buffers when in System Bus or Parallel Slave Port mode.

TABLE 10-8: SUMMARY OF REGISTERS ASSOCIATED WITH PORTD

Name	Bit 7	Bit 6	Bit 5	Bit 4	Bit 3	Bit 2	Bit 1	Bit 0	Value on POR, BOR	Value on all other Resets
PORTD	RD7	RD6	RD5	RD4	RD3	RD2	RD1	RD0	xxxx xxxx	uuuu uuuu
LATD	LATD Data Output Register								xxxx xxxx	uuuu uuuu
TRISD	PORTD Data Direction Register								1111 1111	1111 1111
PSPCON	IBF	OBF	IBOV	PSPMODE	—	—	—	—	0000 ----	0000 ----
MEMCON	EBDIS	—	WAIT1	WAIT0	—	—	WM1	WM0	0-00 --00	0-00 --00

Legend: x = unknown, u = unchanged, — = unimplemented, read as '0'. Shaded cells are not used by PORTD.

PIC18F6520/8520/6620/8620/6720/8720

10.5 PORTE, TRISE and LATE Registers

PORTE is an 8-bit wide, bidirectional port. The corresponding data direction register is TRISE. Setting a TRISE bit (= 1) will make the corresponding PORTE pin an input (i.e., put the corresponding output driver in a high-impedance mode). Clearing a TRISE bit (= 0) will make the corresponding PORTE pin an output (i.e., put the contents of the output latch on the selected pin).

Read-modify-write operations on the LATE register, read and write the latched output value for PORTE.

PORTE is an 8-bit port with Schmitt Trigger input buffers. Each pin is individually configurable as an input or output. PORTE is multiplexed with the CCP module (Table 10-9).

On PIC18F8X20 devices, PORTE is also multiplexed with the system bus as the external memory interface; the I/O bus is available only when the system bus is disabled, by setting the EBDIS bit in the MEMCON register (MEMCON<7>). If the device is configured in Microprocessor or Extended Microcontroller mode, then the PORTE<7:0> becomes the high byte of the address/data bus for the external program memory interface. In Microcontroller mode, the PORTE<2:0> pins become the control inputs for the Parallel Slave Port when bit PSPMODE (PSPCON<4>) is set. (Refer to **Section 4.1.1 “PIC18F8X20 Program Memory Modes”** for more information on program memory modes.)

When the Parallel Slave Port is active, three PORTE pins (RE0/RD/AD8, RE1/WR/AD9 and RE2/CS/AD10) function as its control inputs. This automatically occurs when the PSPMODE bit (PSPCON<4>) is set. Users must also make certain that bits TRISE<2:0> are set to configure the pins as digital inputs and the ADCON1 register is configured for digital I/O. The PORTE PSP control functions are summarized in Table 10-9.

Pin RE7 can be configured as the alternate peripheral pin for CCP module 2 when the device is operating in Microcontroller mode. This is done by clearing the configuration bit, CCP2MX, in configuration register, CONFIG3H (CONFIG3H<0>).

Note: For PIC18F8X20 (80-pin) devices operating in Extended Microcontroller mode, PORTE defaults to the system bus on Power-on Reset.

EXAMPLE 10-5: INITIALIZING PORTE

```
CLRF   PORTE   ; Initialize PORTE by
              ; clearing output
              ; data latches
CLRF   LATE    ; Alternate method
              ; to clear output
              ; data latches
MOVLW  0x03   ; Value used to
              ; initialize data
              ; direction
MOVWF  TRISE   ; Set RE1:RE0 as inputs
              ; RE7:RE2 as outputs
```

PIC18F6520/8520/6620/8620/6720/8720

FIGURE 10-11: PORTE BLOCK DIAGRAM IN I/O MODE

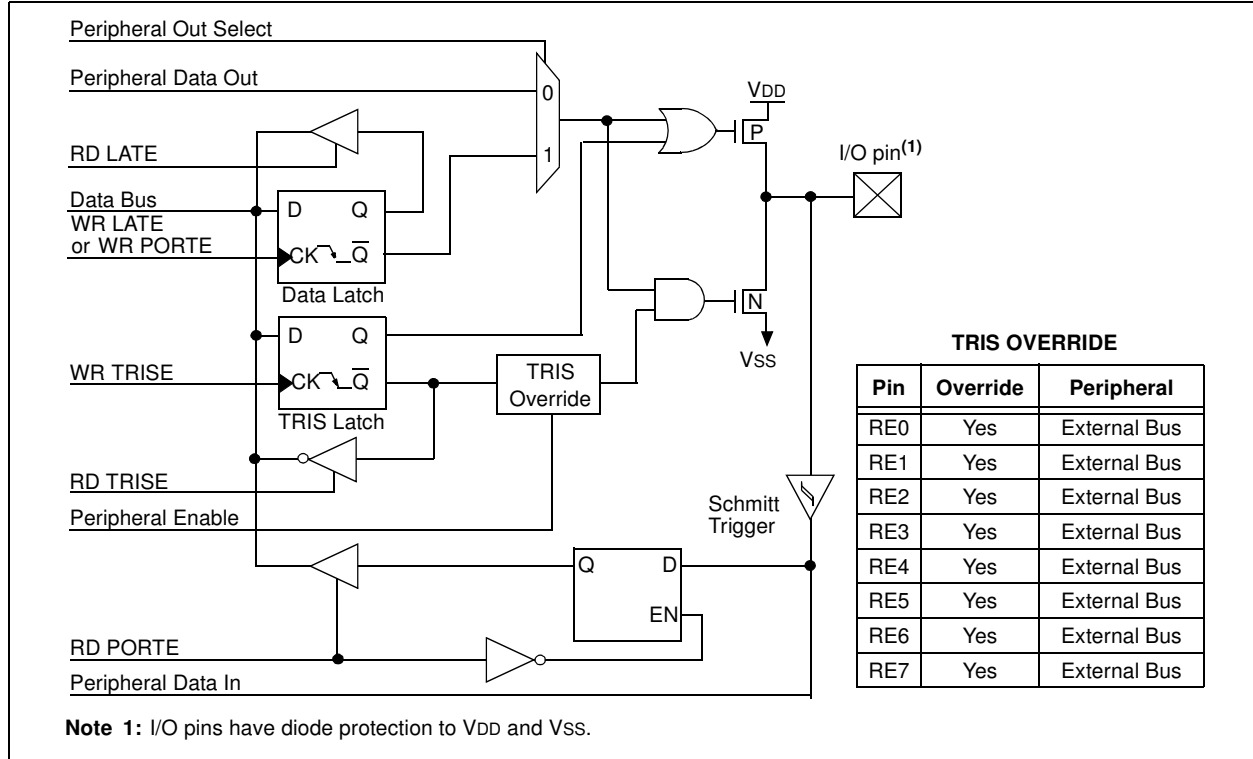
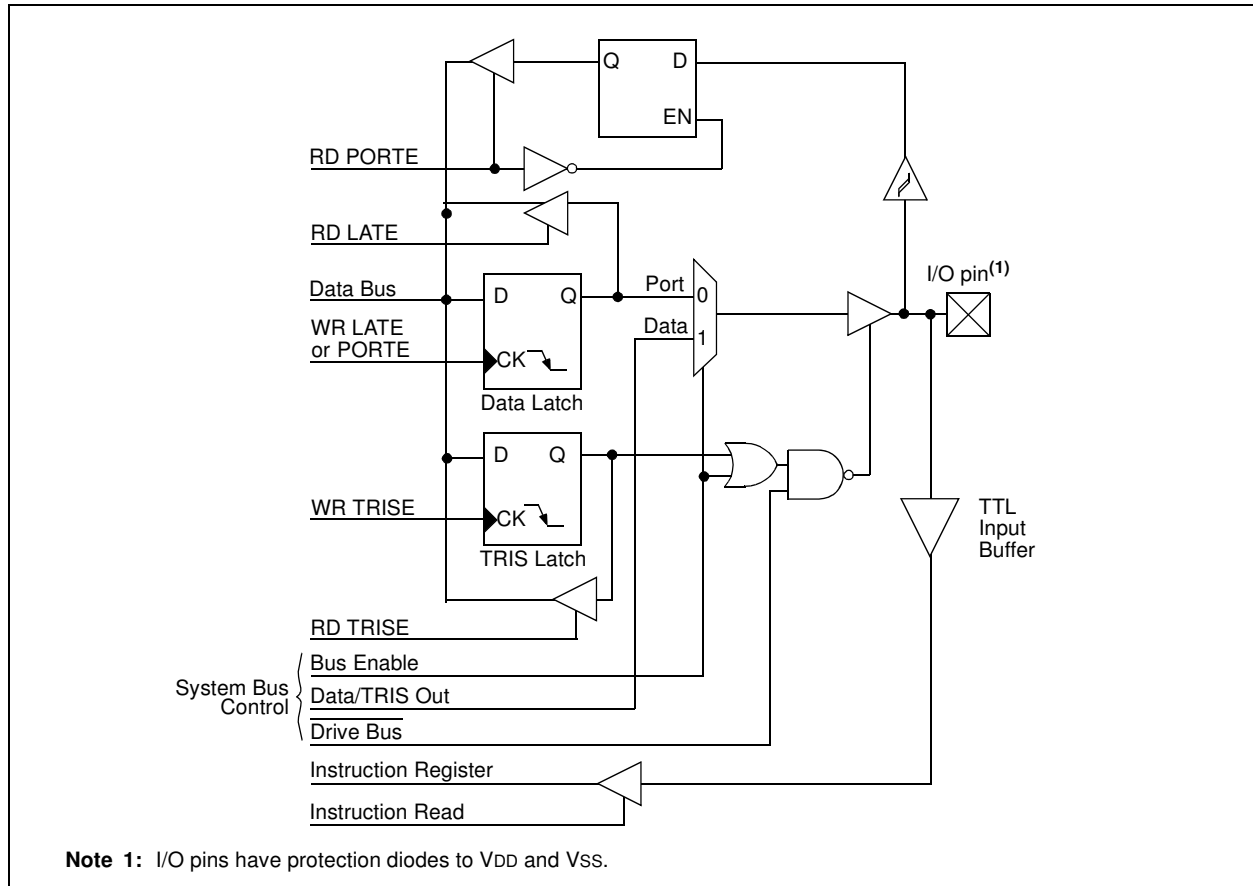

FIGURE 10-12: PORTE BLOCK DIAGRAM IN SYSTEM BUS MODE



PIC18F6520/8520/6620/8620/6720/8720

TABLE 10-9: PORTE FUNCTIONS

Name	Bit#	Buffer Type	Function
RE0/ \overline{RD} /AD8	bit 0	ST/TTL ⁽¹⁾	Input/output port pin, read control for Parallel Slave Port or address/data bit 8 For \overline{RD} (PSP Control mode): 1 = Not a read operation 0 = Read operation, reads PORTD register (if chip selected)
RE1/ \overline{WR} /AD9	bit 1	ST/TTL ⁽¹⁾	Input/output port pin, write control for Parallel Slave Port or address/data bit 9 For \overline{WR} (PSP Control mode): 1 = Not a write operation 0 = Write operation, writes PORTD register (if chip selected)
RE2/ \overline{CS} /AD10	bit 2	ST/TTL ⁽¹⁾	Input/output port pin, chip select control for Parallel Slave Port or address/data bit 10 For \overline{CS} (PSP Control mode): 1 = Device is not selected 0 = Device is selected
RE3/AD11	bit 3	ST/TTL ⁽¹⁾	Input/output port pin or address/data bit 11.
RE4/AD12	bit 4	ST/TTL ⁽¹⁾	Input/output port pin or address/data bit 12.
RE5/AD13	bit 5	ST/TTL ⁽¹⁾	Input/output port pin or address/data bit 13.
RE6/AD14	bit 6	ST/TTL ⁽¹⁾	Input/output port pin or address/data bit 14.
RE7/CCP2/AD15	bit 7	ST/TTL ⁽¹⁾	Input/output port pin, Capture2 input/Compare2 output/PWM output (PIC18F8X20 devices in Microcontroller mode only) or address/data bit 15.

Legend: ST = Schmitt Trigger input, TTL = TTL input

Note 1: Input buffers are Schmitt Triggers when in I/O or CCP mode and TTL buffers when in System Bus or PSP Control mode.

TABLE 10-10: SUMMARY OF REGISTERS ASSOCIATED WITH PORTE

Name	Bit 7	Bit 6	Bit 5	Bit 4	Bit 3	Bit 2	Bit 1	Bit 0	Value on POR, BOR	Value on all other Resets
TRISE	PORTE Data Direction Control Register								1111 1111	1111 1111
PORTE	Read PORTE pin/Write PORTE Data Latch								xxxx xxxx	uuuu uuuu
LATE	Read PORTE Data Latch/Write PORTE Data Latch								xxxx xxxx	uuuu uuuu
MEMCON	EBDIS	—	WAIT1	WAIT0	—	—	WM1	WM0	0-00 --00	0000 --00
PSPCON	IBF	OBF	IBOV	PSPMODE	—	—	—	—	0000 ----	0000 ----

Legend: x = unknown, u = unchanged. Shaded cells are not used by PORTE.

PIC18F6520/8520/6620/8620/6720/8720

10.6 PORTF, LATF and TRISF Registers

PORTF is an 8-bit wide, bidirectional port. The corresponding data direction register is TRISF. Setting a TRISF bit (= 1) will make the corresponding PORTF pin an input (i.e., put the corresponding output driver in a high-impedance mode). Clearing a TRISF bit (= 0) will make the corresponding PORTF pin an output (i.e., put the contents of the output latch on the selected pin).

Read-modify-write operations on the LATF register, read and write the latched output value for PORTF.

PORTF is multiplexed with several analog peripheral functions, including the A/D converter inputs and comparator inputs, outputs and voltage reference.

Note 1: On a Power-on Reset, the RF6:RF0 pins are configured as inputs and read as '0'.

2: To configure PORTF as digital I/O, turn off comparators and set ADCON1 value.

EXAMPLE 10-6: INITIALIZING PORTF

```

CLRF   PORTF   ; Initialize PORTF by
              ; clearing output
              ; data latches
CLRF   LATF    ; Alternate method
              ; to clear output
              ; data latches
MOVLW  0x07   ;
MOVWF  CMCON  ; Turn off comparators
MOVLW  0x0F   ;
MOVWF  ADCON1 ; Set PORTF as digital I/O
MOVLW  0xCF   ; Value used to
              ; initialize data
              ; direction
MOVWF  TRISF  ; Set RF3:RF0 as inputs
              ; RF5:RF4 as outputs
              ; RF7:RF6 as inputs
    
```

FIGURE 10-13: PORTF RF1/AN6/C2OUT, RF2/AN7/C1OUT PINS BLOCK DIAGRAM

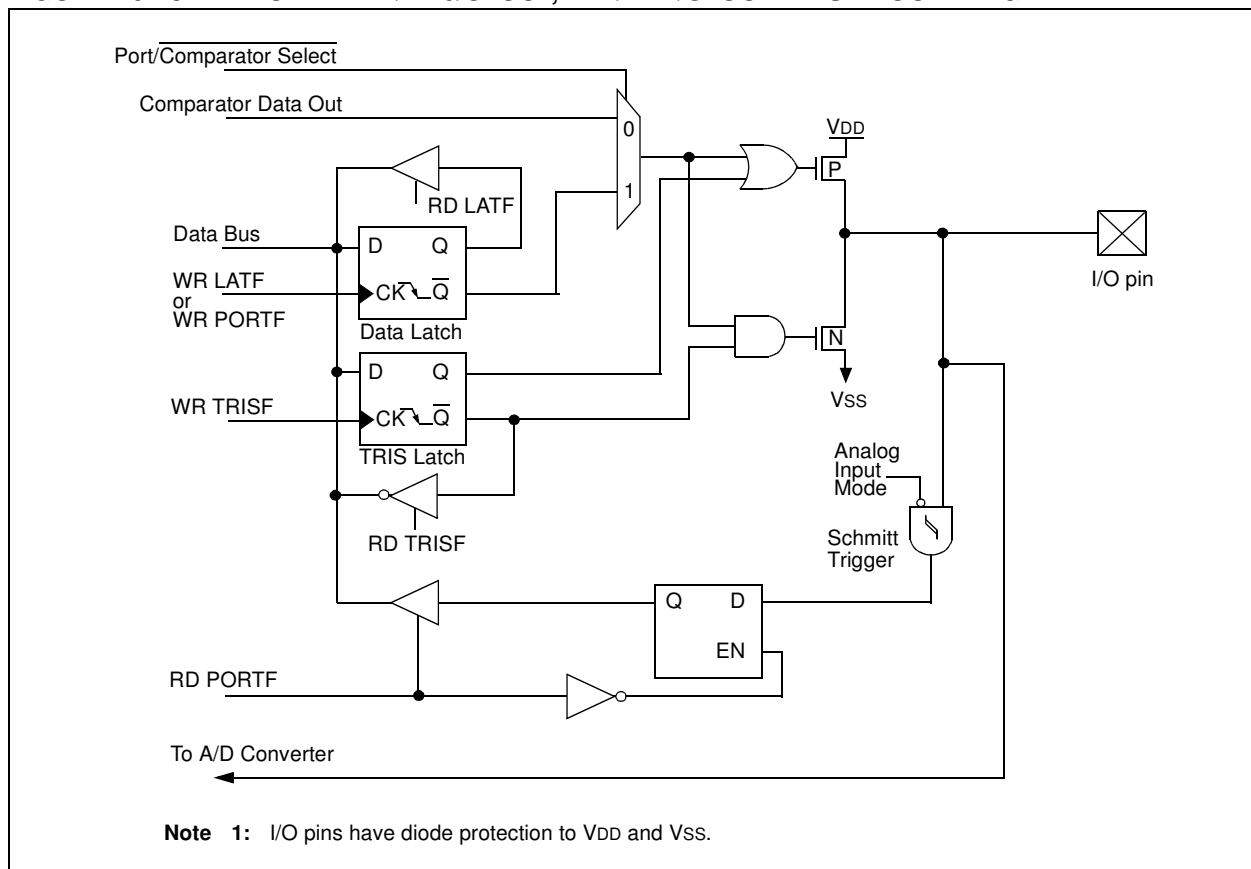

PIC18F6520/8520/6620/8620/6720/8720

FIGURE 10-14: RF6:RF3 AND RF0 PINS BLOCK DIAGRAM

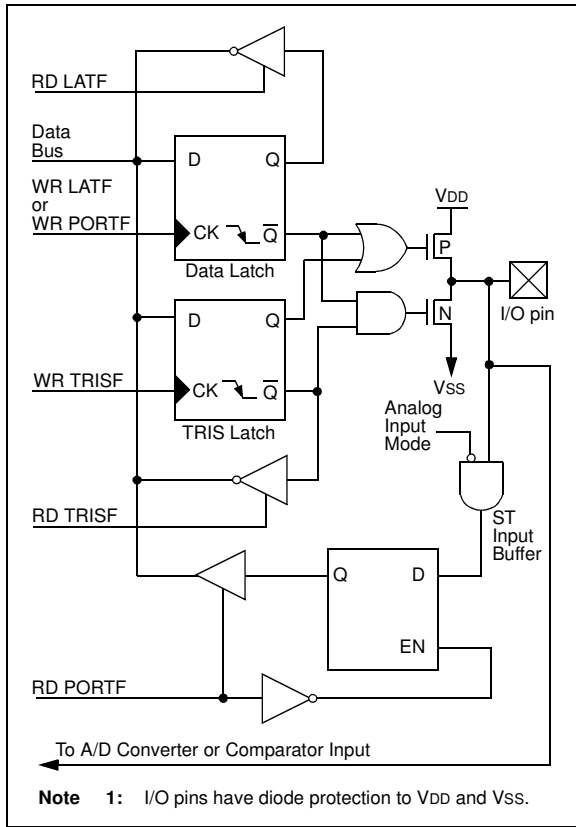
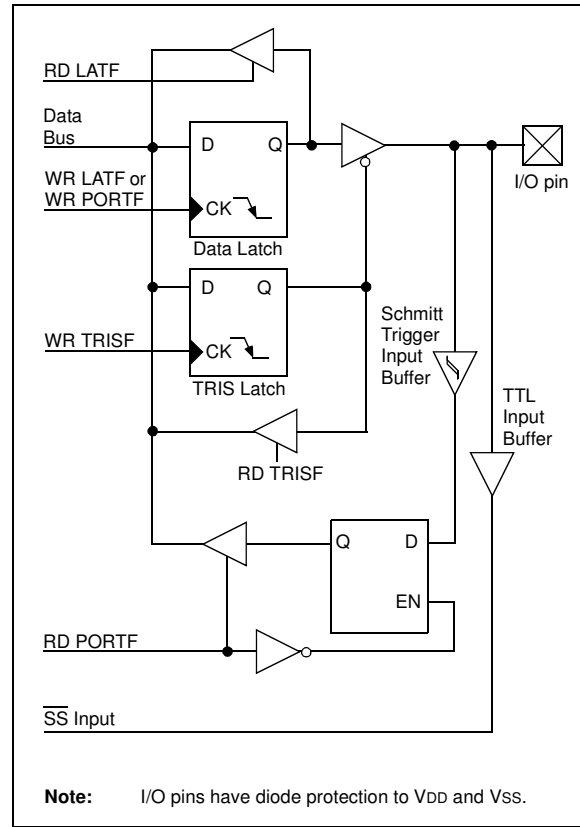

FIGURE 10-15: RF7 PIN BLOCK DIAGRAM



PIC18F6520/8520/6620/8620/6720/8720

TABLE 10-11: PORTF FUNCTIONS

Name	Bit#	Buffer Type	Function
RF0/AN5	bit 0	ST	Input/output port pin or analog input.
RF1/AN6/C2OUT	bit 1	ST	Input/output port pin, analog input or comparator 2 output.
RF2/AN7/C1OUT	bit 2	ST	Input/output port pin, analog input or comparator 1 output.
RF3/AN8	bit 3	ST	Input/output port pin or analog input/comparator input.
RF4/AN9	bit 4	ST	Input/output port pin or analog input/comparator input.
RF5/AN10/CVREF	bit 5	ST	Input/output port pin, analog input/comparator input or comparator reference output.
RF6/AN11	bit 6	ST	Input/output port pin or analog input/comparator input.
RF7/ \overline{SS}	bit 7	ST/TTL	Input/output port pin or slave select pin for synchronous serial port.

Legend: ST = Schmitt Trigger input, TTL = TTL input

TABLE 10-12: SUMMARY OF REGISTERS ASSOCIATED WITH PORTF

Name	Bit 7	Bit 6	Bit 5	Bit 4	Bit 3	Bit 2	Bit 1	Bit 0	Value on POR, BOR	Value on all other Resets
TRISF	PORTF Data Direction Control Register								1111 1111	1111 1111
PORTF	Read PORTF pin/Write PORTF Data Latch								xxxx xxxx	uuuu uuuu
LATF	Read PORTF Data Latch/Write PORTF Data Latch								0000 0000	uuuu uuuu
ADCON1	—	—	VCFG1	VCFG0	PCFG3	PCFG2	PCFG1	PCFG0	--00 0000	--00 0000
CMCON	C2OUT	C1OUT	C2INV	C1INV	CIS	CM2	CM1	CM0	0000 0000	0000 0000
CVRCON	CVREN	CVROE	CVRR	CVRSS	CVR3	CVR2	CVR1	CVR0	0000 0000	0000 0000

Legend: x = unknown, u = unchanged. Shaded cells are not used by PORTF.

PIC18F6520/8520/6620/8620/6720/8720

10.7 PORTG, TRISG and LATG Registers

PORTG is a 5-bit wide, bidirectional port. The corresponding data direction register is TRISG. Setting a TRISG bit (= 1) will make the corresponding PORTG pin an input (i.e., put the corresponding output driver in a high-impedance mode). Clearing a TRISG bit (= 0) will make the corresponding PORTG pin an output (i.e., put the contents of the output latch on the selected pin).

The Data Latch register (LATG) is also memory mapped. Read-modify-write operations on the LATG register, read and write the latched output value for PORTG.

PORTG is multiplexed with both CCP and USART functions (Table 10-13). PORTG pins have Schmitt Trigger input buffers.

When enabling peripheral functions, care should be taken in defining TRIS bits for each PORTG pin. Some peripherals override the TRIS bit to make a pin an output, while other peripherals override the TRIS bit to

make a pin an input. The user should refer to the corresponding peripheral section for the correct TRIS bit settings.

Note: On a Power-on Reset, these pins are configured as digital inputs.

The pin override value is not loaded into the TRIS register. This allows read-modify-write of the TRIS register, without concern due to peripheral overrides.

EXAMPLE 10-7: INITIALIZING PORTG

```
CLRF   PORTG   ; Initialize PORTG by
              ; clearing output
              ; data latches
CLRF   LATG    ; Alternate method
              ; to clear output
              ; data latches
MOVLW  0x04   ; Value used to
              ; initialize data
              ; direction
MOVWF  TRISG  ; Set RG1:RG0 as outputs
              ; RG2 as input
              ; RG4:RG3 as inputs
```

FIGURE 10-16: PORTG BLOCK DIAGRAM (PERIPHERAL OUTPUT OVERRIDE)

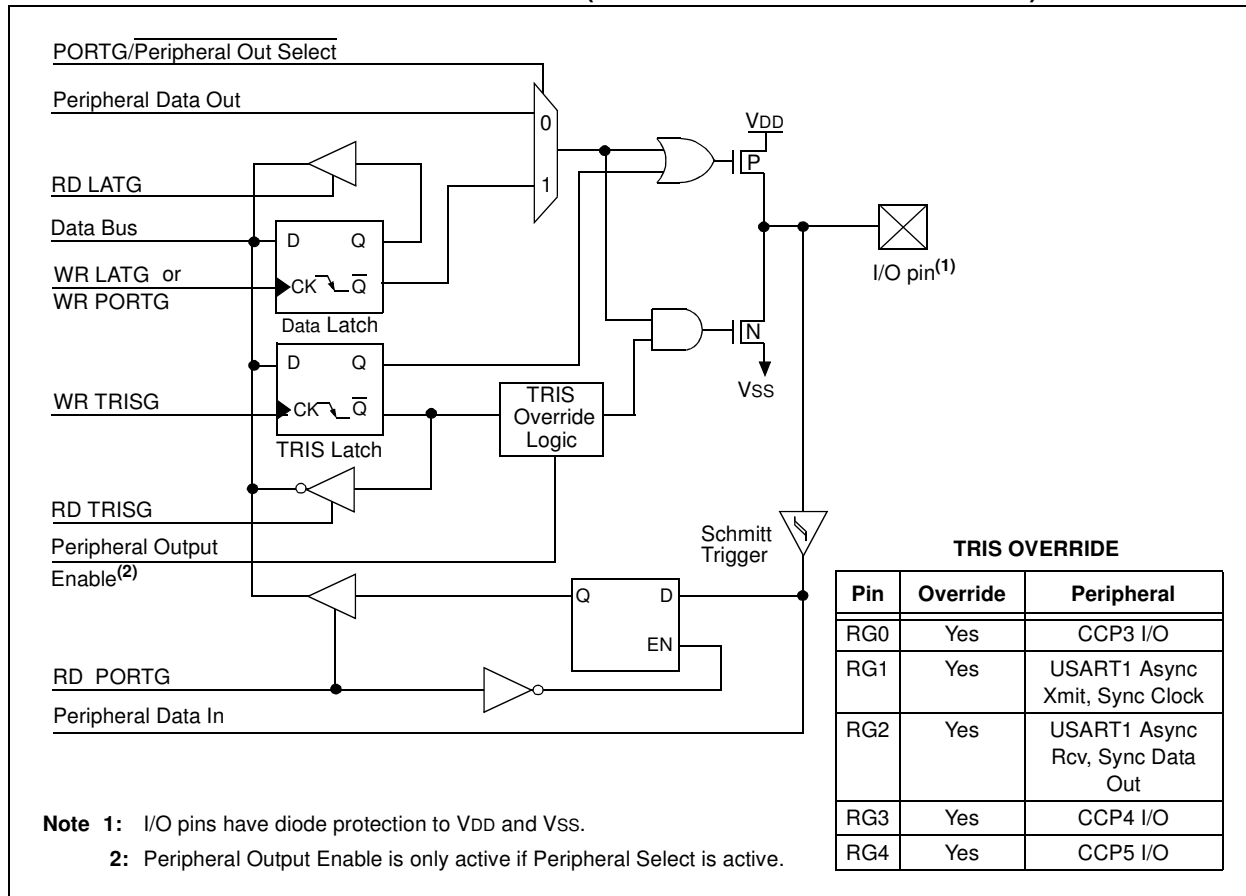

PIC18F6520/8520/6620/8620/6720/8720

TABLE 10-13: PORTG FUNCTIONS

Name	Bit#	Buffer Type	Function
RG0/CCP3	bit 0	ST	Input/output port pin or Capture3 input/Compare3 output/PWM3 output.
RG1/TX2/CK2	bit 1	ST	Input/output port pin, addressable USART2 asynchronous transmit or addressable USART2 synchronous clock.
RG2/RX2/DT2	bit 2	ST	Input/output port pin, addressable USART2 asynchronous receive or addressable USART2 synchronous data.
RG3/CCP4	bit 3	ST	Input/output port pin or Capture4 input/Compare4 output/PWM4 output.
RG4/CCP5	bit 4	ST	Input/output port pin or Capture5 input/Compare5 output/PWM5 output.

Legend: ST = Schmitt Trigger input

TABLE 10-14: SUMMARY OF REGISTERS ASSOCIATED WITH PORTG

Name	Bit 7	Bit 6	Bit 5	Bit 4	Bit 3	Bit 2	Bit 1	Bit 0	Value on POR, BOR	Value on all other Resets
PORTG	—	—	—	Read PORTF pin/Write PORTF Data Latch				---	x xxxx	---u uuuu
LATG	—	—	—	LATG Data Output Register				---	x xxxx	---u uuuu
TRISG	—	—	—	Data Direction Control Register for PORTG				---	1 1111	---1 1111

Legend: x = unknown, u = unchanged

PIC18F6520/8520/6620/8620/6720/8720

10.8 PORTH, LATH and TRISH Registers

Note: PORTH is available only on PIC18F8X20 devices.

PORTH is an 8-bit wide, bidirectional I/O port. The corresponding data direction register is TRISH. Setting a TRISH bit (= 1) will make the corresponding PORTH pin an input (i.e., put the corresponding output driver in a high-impedance mode). Clearing a TRISH bit (= 0) will make the corresponding PORTH pin an output (i.e., put the contents of the output latch on the selected pin).

Read-modify-write operations on the LATH register, read and write the latched output value for PORTH.

Pins RH7:RH4 are multiplexed with analog inputs AN15:AN12. Pins RH3:RH0 are multiplexed with the system bus as the external memory interface; they are the high-order address bits, A19:A16. By default, pins RH7:RH4 are enabled as A/D inputs and pins RH3:RH0 are enabled as the system address bus. Register ADCON1 configures RH7:RH4 as I/O or A/D inputs. Register MEMCON configures RH3:RH0 as I/O or system bus pins.

Note 1: On Power-on Reset, PORTH pins RH7:RH4 default to A/D inputs and read as '0'.

2: On Power-on Reset, PORTH pins RH3:RH0 default to system bus signals.

EXAMPLE 10-8: INITIALIZING PORTH

```

CLRF   PORTH   ; Initialize PORTH by
               ; clearing output
               ; data latches
CLRF   LATH     ; Alternate method
               ; to clear output
               ; data latches
MOVLW  0Fh     ;
MOVWF  ADCON1  ;
MOVLW  0CFh    ; Value used to
               ; initialize data
               ; direction
MOVWF  TRISH   ; Set RH3:RH0 as inputs
               ; RH5:RH4 as outputs
               ; RH7:RH6 as inputs
    
```

FIGURE 10-17: RH3:RH0 PINS BLOCK DIAGRAM IN I/O MODE

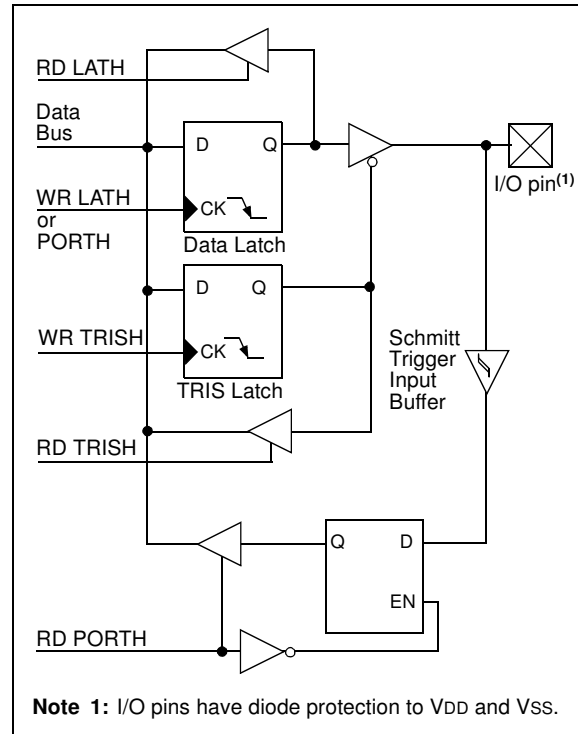
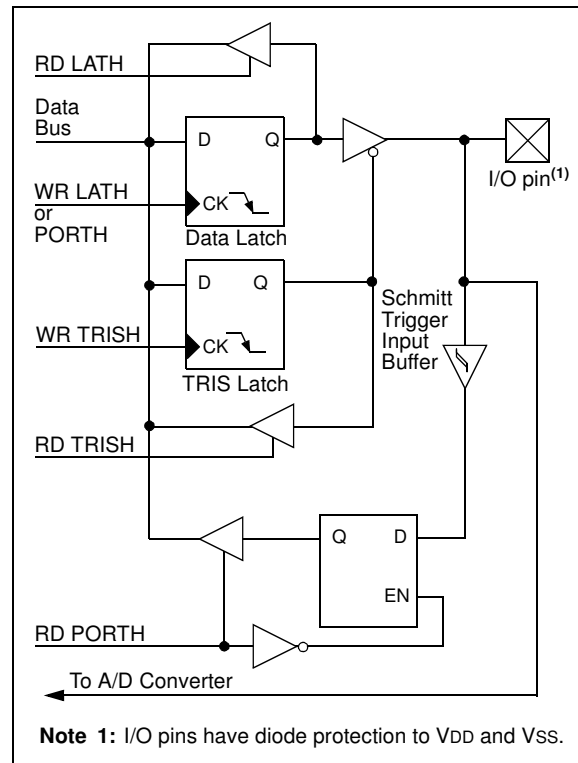
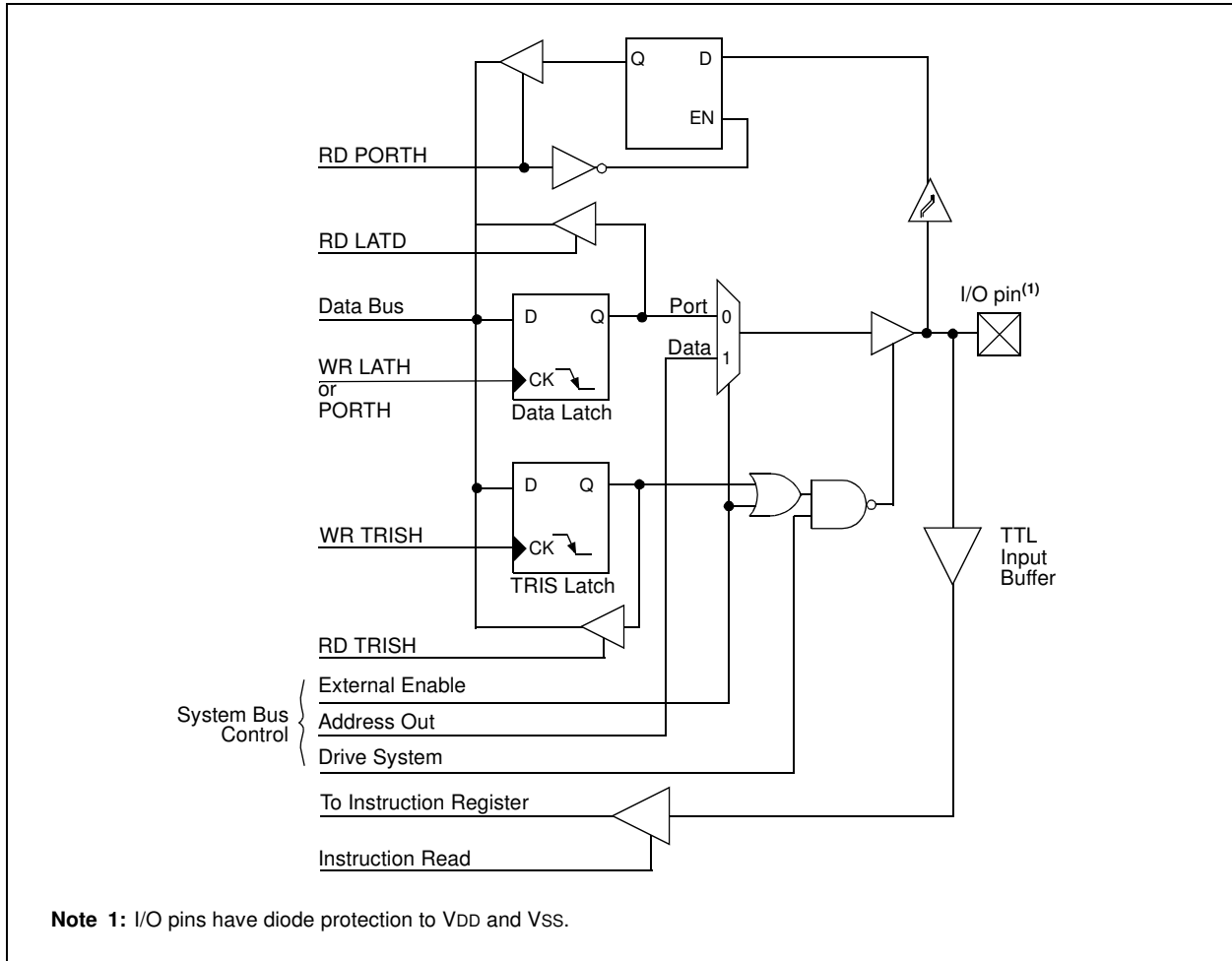

FIGURE 10-18: RH7:RH4 PINS BLOCK DIAGRAM IN I/O MODE



PIC18F6520/8520/6620/8620/6720/8720

FIGURE 10-19: RH3:RH0 PINS BLOCK DIAGRAM IN SYSTEM BUS MODE



PIC18F6520/8520/6620/8620/6720/8720

TABLE 10-15: PORTH FUNCTIONS

Name	Bit#	Buffer Type	Function
RH0/A16	bit 0	ST/TTL ⁽¹⁾	Input/output port pin or address bit 16 for external memory interface.
RH1/A17	bit 1	ST/TTL ⁽¹⁾	Input/output port pin or address bit 17 for external memory interface.
RH2/A18	bit 2	ST/TTL ⁽¹⁾	Input/output port pin or address bit 18 for external memory interface.
RH3/A19	bit 3	ST/TTL ⁽¹⁾	Input/output port pin or address bit 19 for external memory interface.
RH4/AN12	bit 4	ST	Input/output port pin or analog input channel 12.
RH5/AN13	bit 5	ST	Input/output port pin or analog input channel 13.
RH6/AN14	bit 6	ST	Input/output port pin or analog input channel 14.
RH7/AN15	bit 7	ST	Input/output port pin or analog input channel 15.

Legend: ST = Schmitt Trigger input, TTL = TTL input

Note 1: Input buffers are Schmitt Triggers when in I/O mode and TTL buffers when in System Bus or Parallel Slave Port mode.

TABLE 10-16: SUMMARY OF REGISTERS ASSOCIATED WITH PORTH

Name	Bit 7	Bit 6	Bit 5	Bit 4	Bit 3	Bit 2	Bit 1	Bit 0	Value on POR, BOR	Value on all other Resets
TRISH	PORTH Data Direction Control Register								1111 1111	1111 1111
PORTH	Read PORTH pin/Write PORTH Data Latch								xxxx xxxx	uuuu uuuu
LATH	Read PORTH Data Latch/Write PORTH Data Latch								xxxx xxxx	uuuu uuuu
ADCON1	—	—	VCFG1	VCFG0	PCFG3	PCFG2	PCFG1	PCFG0	--00 0000	--00 0000
MEMCON	EBDIS	—	WAIT1	WAIT0	—	—	WM1	WM0	0-00 --00	0-00 --00

Legend: x = unknown, u = unchanged, — = unimplemented. Shaded cells are not used by PORTH.

PIC18F6520/8520/6620/8620/6720/8720

10.9 PORTJ, TRISJ and LATJ Registers

Note: PORTJ is available only on PIC18F8X20 devices.

PORTJ is an 8-bit wide, bidirectional port. The corresponding data direction register is TRISJ. Setting a TRISJ bit (= 1) will make the corresponding PORTJ pin an input (i.e., put the corresponding output driver in a high-impedance mode). Clearing a TRISJ bit (= 0) will make the corresponding PORTJ pin an output (i.e., put the contents of the output latch on the selected pin).

The Data Latch register (LATJ) is also memory mapped. Read-modify-write operations on the LATJ register, read and write the latched output value for PORTJ.

PORTJ is multiplexed with the system bus as the external memory interface; I/O port functions are only available when the system bus is disabled. When operating as the external memory interface, PORTJ provides the control signal to external memory devices. The RJ5 pin is not multiplexed with any system bus functions.

When enabling peripheral functions, care should be taken in defining TRIS bits for each PORTJ pin. Some peripherals override the TRIS bit to make a pin an output, while other peripherals override the TRIS bit to make a pin an input. The user should refer to the corresponding peripheral section for the correct TRIS bit settings.

Note: On a Power-on Reset, these pins are configured as digital inputs.

The pin override value is not loaded into the TRIS register. This allows read-modify-write of the TRIS register, without concern due to peripheral overrides.

EXAMPLE 10-9: INITIALIZING PORTJ

```
CLRF   PORTJ   ; Initialize PORTJ by
               ; clearing output
               ; data latches
CLRF   LATJ    ; Alternate method
               ; to clear output
               ; data latches
MOVLW  0xCF    ; Value used to
               ; initialize data
               ; direction
MOVWF  TRISJ   ; Set RJ3:RJ0 as inputs
               ; RJ5:RJ4 as output
               ; RJ7:RJ6 as inputs
```

FIGURE 10-20: PORTJ BLOCK DIAGRAM IN I/O MODE

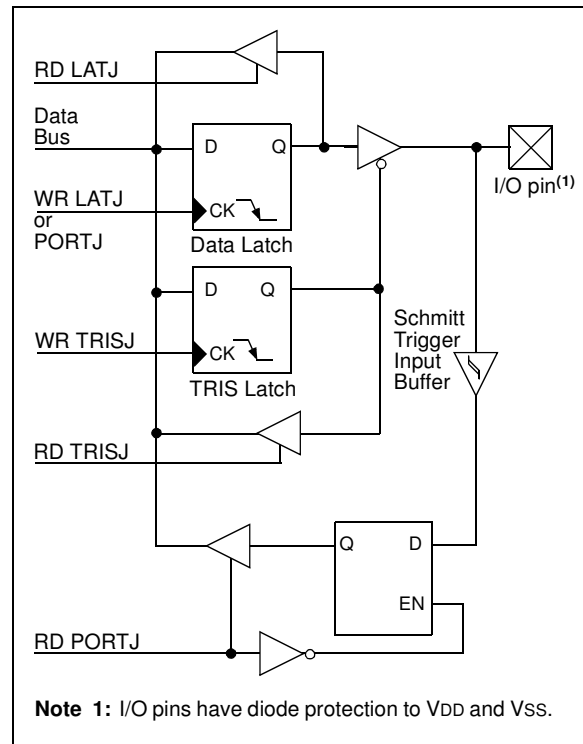

Note 1: I/O pins have diode protection to VDD and VSS.

PIC18F6520/8520/6620/8620/6720/8720

FIGURE 10-21: RJ4:RJ0 PINS BLOCK DIAGRAM IN SYSTEM BUS MODE

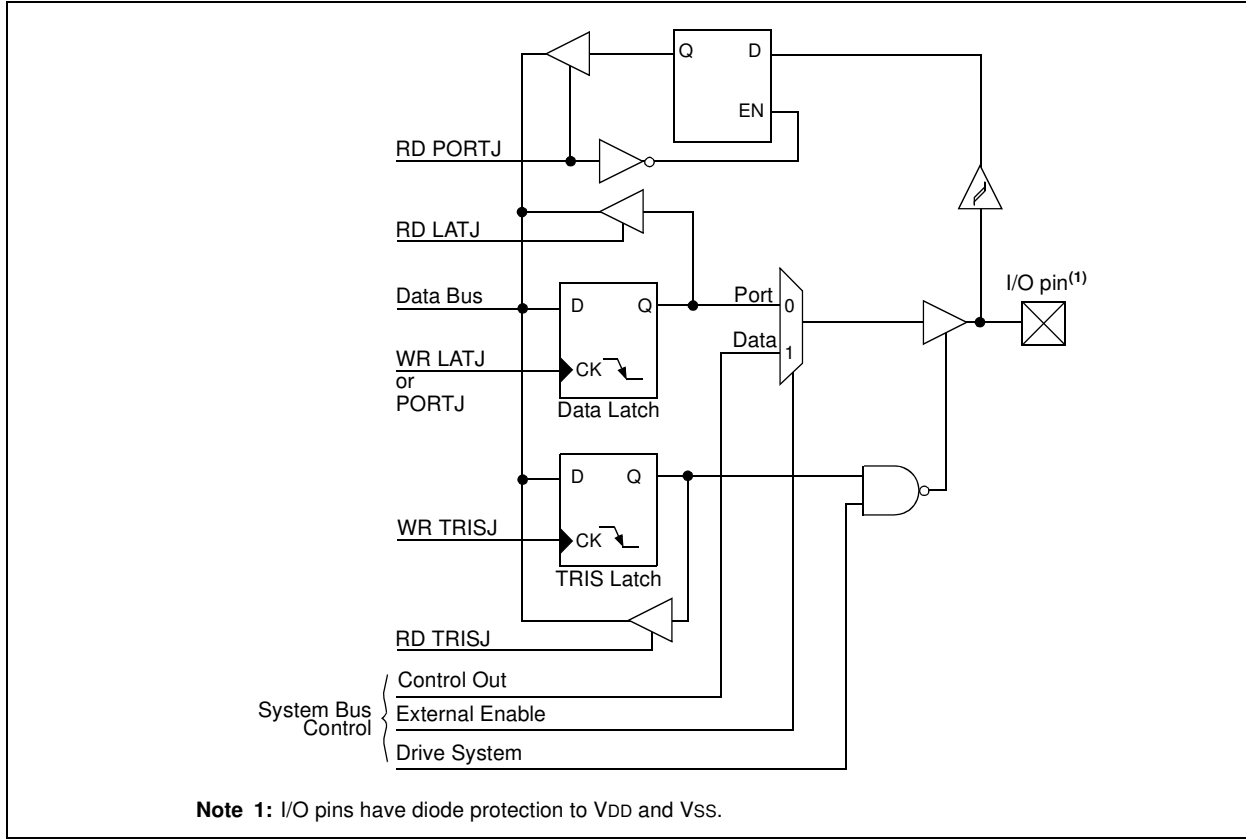
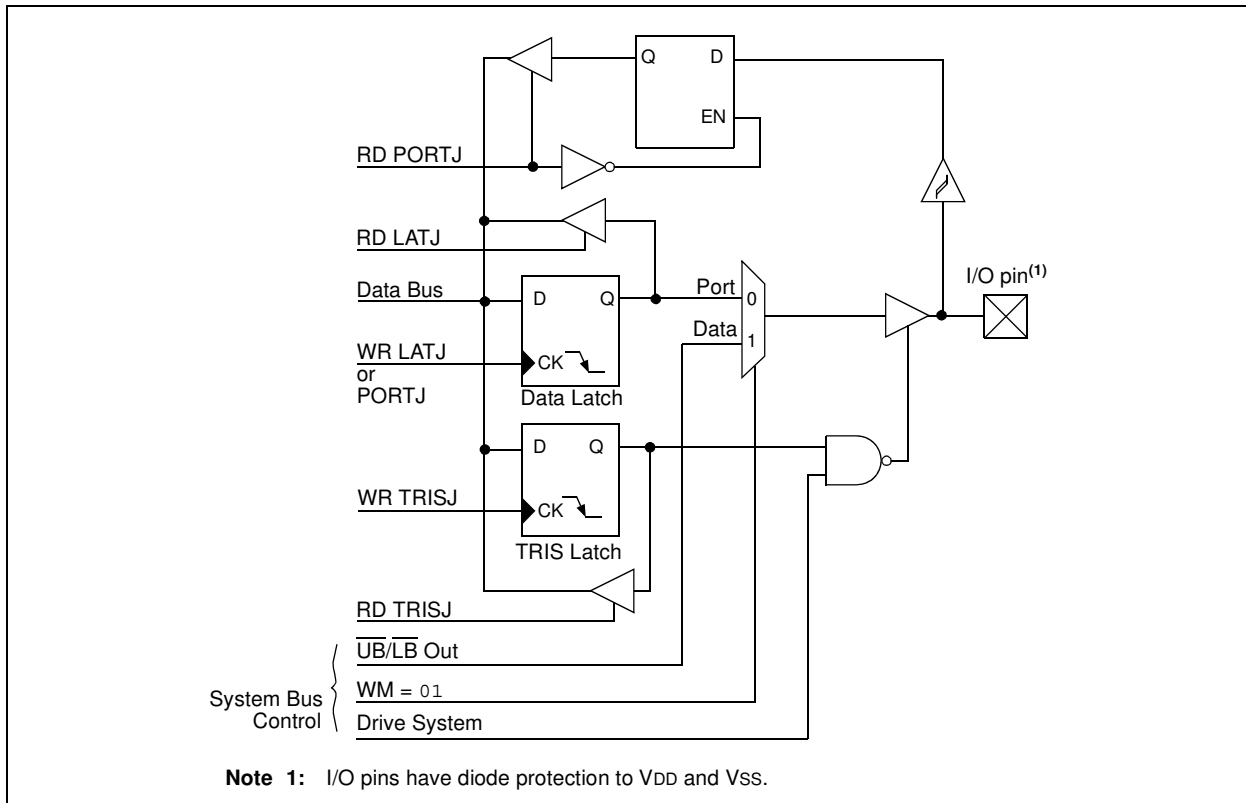

FIGURE 10-22: RJ7:RJ6 PINS BLOCK DIAGRAM IN SYSTEM BUS MODE



PIC18F6520/8520/6620/8620/6720/8720

TABLE 10-17: PORTJ FUNCTIONS

Name	Bit#	Buffer Type	Function
RJ0/ALE	bit 0	ST	Input/output port pin or address latch enable control for external memory interface.
RJ1/ \overline{OE}	bit 1	ST	Input/output port pin or output enable control for external memory interface.
RJ2/ \overline{WRL}	bit 2	ST	Input/output port pin or write low byte control for external memory interface.
RJ3/ \overline{WRH}	bit 3	ST	Input/output port pin or write high byte control for external memory interface.
RJ4/BA0	bit 4	ST	Input/output port pin or byte address 0 control for external memory interface.
RJ5/ \overline{CE}	bit 5	ST	Input/output port pin or chip enable control for external memory interface.
RJ6/ \overline{LB}	bit 6	ST	Input/output port pin or lower byte select control for external memory interface.
RJ7/ \overline{UB}	bit 7	ST	Input/output port pin or upper byte select control for external memory interface.

Legend: ST = Schmitt Trigger input

TABLE 10-18: SUMMARY OF REGISTERS ASSOCIATED WITH PORTJ

Name	Bit 7	Bit 6	Bit 5	Bit 4	Bit 3	Bit 2	Bit 1	Bit 0	Value on POR, BOR	Value on all other Resets
PORTJ	Read PORTJ pin/Write PORTJ Data Latch								xxxx xxxx	uuuu uuuu
LATJ	LATJ Data Output Register								xxxx xxxx	uuuu uuuu
TRISJ	Data Direction Control Register for PORTJ								1111 1111	1111 1111

Legend: x = unknown, u = unchanged

PIC18F6520/8520/6620/8620/6720/8720

10.10 Parallel Slave Port

PORTD also operates as an 8-bit wide Parallel Slave Port, or microprocessor port, when control bit PSPMODE (PSPCON<4>) is set. It is asynchronously readable and writable by the external world through the \overline{RD} control input pin, RE0/ \overline{RD} /AD8 and the \overline{WR} control input pin, RE1/ \overline{WR} /AD9.

Note: For PIC18F8X20 devices, the Parallel Slave Port is available only in Microcontroller mode.

The PSP can directly interface to an 8-bit microprocessor data bus. The external microprocessor can read or write the PORTD latch as an 8-bit latch. Setting bit PSPMODE enables port pin RE0/ \overline{RD} /AD8 to be the \overline{RD} input, RE1/ \overline{WR} /AD9 to be the \overline{WR} input and RE2/ \overline{CS} /AD10 to be the \overline{CS} (Chip Select) input. For this functionality, the corresponding data direction bits of the TRISE register (TRISE<2:0>) must be configured as inputs (set). The A/D port configuration bits, PCFG2:PCFG0 (ADCON1<2:0>), must be set which will configure pins RE2:RE0 as digital I/O.

A write to the PSP occurs when both the \overline{CS} and \overline{WR} lines are first detected low. A read from the PSP occurs when both the \overline{CS} and \overline{RD} lines are first detected low.

The PORTE I/O pins become control inputs for the microprocessor port when bit PSPMODE (PSPCON<4>) is set. In this mode, the user must make sure that the TRISE<2:0> bits are set (pins are configured as digital inputs) and the ADCON1 is configured for digital I/O. In this mode, the input buffers are TTL.

FIGURE 10-23: PORTD AND PORTE BLOCK DIAGRAM (PARALLEL SLAVE PORT)

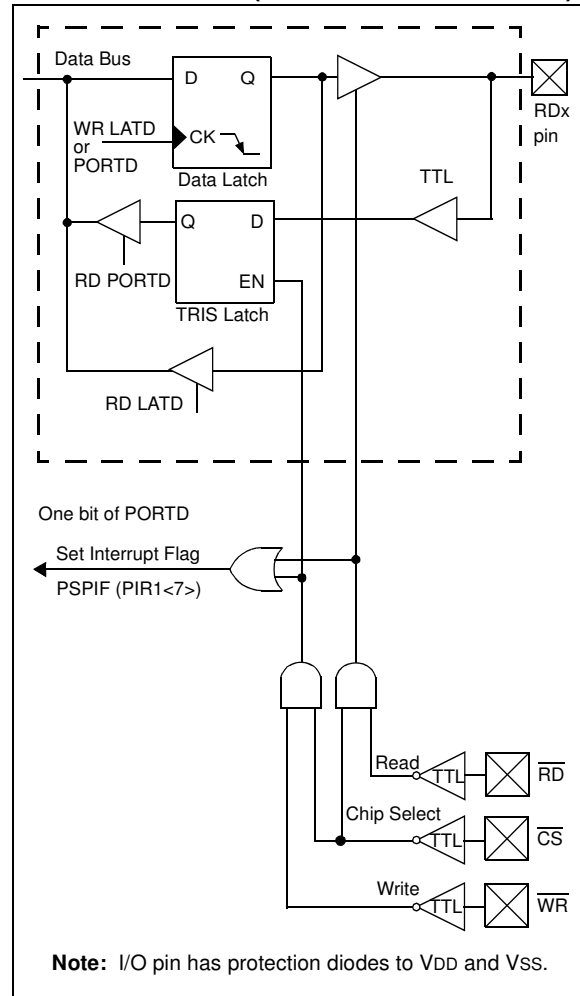

PIC18F6520/8520/6620/8620/6720/8720

REGISTER 10-1: PSPCON REGISTER

R-0	R-0	R/W-0	R/W-0	U-0	U-0	U-0	U-0
IBF	OBF	IBOV	PSPMODE	—	—	—	—
bit 7				bit 0			

- bit 7 **IBF:** Input Buffer Full Status bit
 1 = A word has been received and is waiting to be read by the CPU
 0 = No word has been received
- bit 6 **OBF:** Output Buffer Full Status bit
 1 = The output buffer still holds a previously written word
 0 = The output buffer has been read
- bit 5 **IBOV:** Input Buffer Overflow Detect bit
 1 = A write occurred when a previously input word has not been read
 (must be cleared in software)
 0 = No overflow occurred
- bit 4 **PSPMODE:** Parallel Slave Port Mode Select bit
 1 = Parallel Slave Port mode
 0 = General Purpose I/O mode
- bit 3-0 **Unimplemented:** Read as '0'

Legend:

R = Readable bit W = Writable bit U = Unimplemented bit, read as '0'
 - n = Value at POR '1' = Bit is set '0' = Bit is cleared x = Bit is unknown

FIGURE 10-24: PARALLEL SLAVE PORT WRITE WAVEFORMS

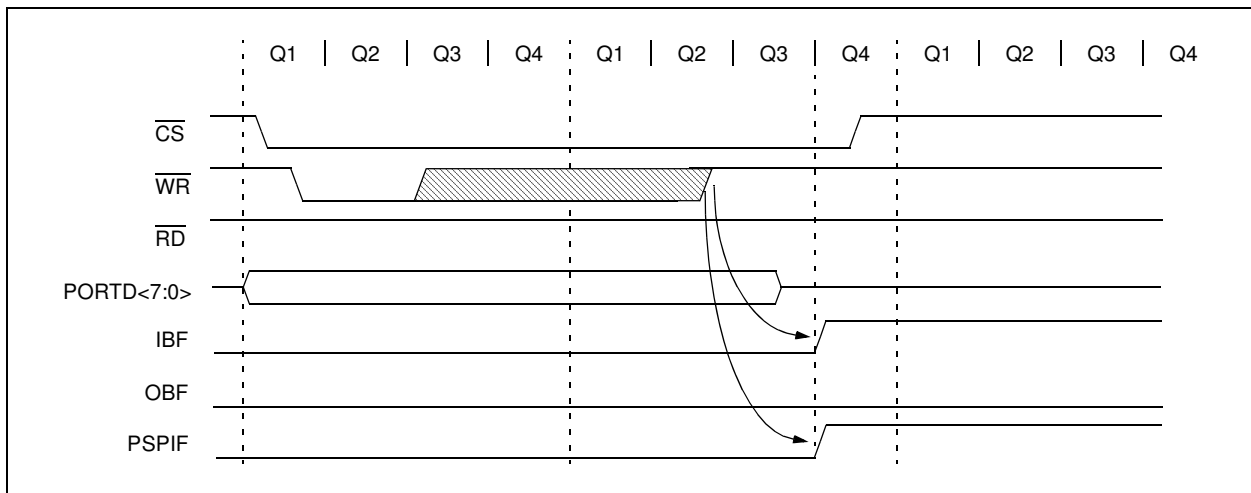

PIC18F6520/8520/6620/8620/6720/8720

FIGURE 10-25: PARALLEL SLAVE PORT READ WAVEFORMS

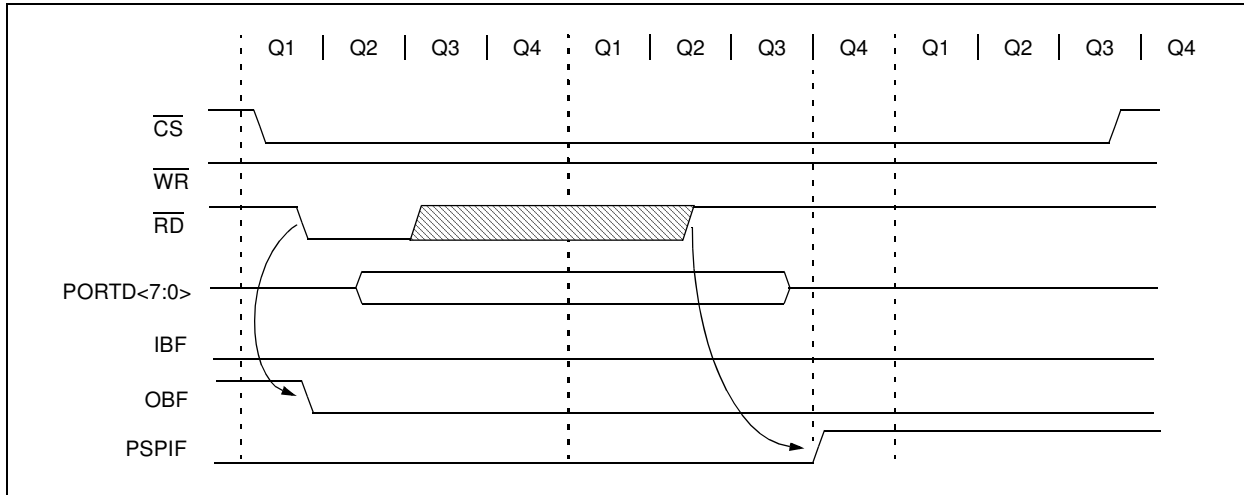

TABLE 10-19: REGISTERS ASSOCIATED WITH PARALLEL SLAVE PORT

Name	Bit 7	Bit 6	Bit 5	Bit 4	Bit 3	Bit 2	Bit 1	Bit 0	Value on POR, BOR	Value on all other Resets
PORTD	Port Data Latch when written; Port pins when read								xxxx xxxx	uuuu uuuu
LATD	LATD Data Output bits								xxxx xxxx	uuuu uuuu
TRISD	PORTD Data Direction bits								1111 1111	1111 1111
PORTE	—	—	—	—	—	Read PORTE pin/ Write PORTE Data Latch			0000 0000	0000 0000
LATE	—	—	—	—	—	LATE Data Output bits			xxxx xxxx	uuuu uuuu
TRISE	—	—	—	—	—	PORTE Data Direction bits			1111 1111	1111 1111
PSPCON	IBF	OBF	IBOV	PSPMODE	—	—	—	—	0000 ----	0000 ----
INTCON	GIE/ GIEH	PEIE/ GIEL	TMR0IF	INT0IE	RBIE	TMR0IF	INT0IF	RBIF	0000 0000	0000 0000
PIR1	PSPIF ⁽¹⁾	ADIF	RCIF	TXIF	SSPIF	CCP1IF	TMR2IF	TMR1IF	0000 0000	0000 0000
PIE1	PSPIE ⁽¹⁾	ADIE	RCIE	TXIE	SSPIE	CCP1IE	TMR2IE	TMR1IE	0000 0000	0000 0000
IPR1	PSPIP ⁽¹⁾	ADIP	RCIP	TXIP	SSPIP	CCP1IP	TMR2IP	TMR1IP	0111 1111	0111 1111

Legend: x = unknown, u = unchanged, — = unimplemented, read as '0'. Shaded cells are not used by the Parallel Slave Port.

Note 1: Enabled only in Microcontroller mode for PIC18F8X20 devices.

PIC18F6520/8520/6620/8620/6720/8720

11.0 TIMER0 MODULE

The Timer0 module has the following features:

- Software selectable as an 8-bit or 16-bit timer/counter
- Readable and writable
- Dedicated 8-bit software programmable prescaler
- Clock source selectable to be external or internal
- Interrupt-on-overflow from FFh to 00h in 8-bit mode and FFFFh to 0000h in 16-bit mode
- Edge select for external clock

Figure 11-1 shows a simplified block diagram of the Timer0 module in 8-bit mode and Figure 11-2 shows a simplified block diagram of the Timer0 module in 16-bit mode.

The T0CON register (Register 11-1) is a readable and writable register that controls all the aspects of Timer0, including the prescale selection.

REGISTER 11-1: T0CON: TIMER0 CONTROL REGISTER

R/W-1	R/W-1	R/W-1	R/W-1	R/W-1	R/W-1	R/W-1	R/W-1
TMR0ON	T08BIT	T0CS	T0SE	PSA	T0PS2	T0PS1	T0PS0
bit 7							bit 0

- bit 7 **TMR0ON:** Timer0 On/Off Control bit
 1 = Enables Timer0
 0 = Stops Timer0
- bit 6 **T08BIT:** Timer0 8-bit/16-bit Control bit
 1 = Timer0 is configured as an 8-bit timer/counter
 0 = Timer0 is configured as a 16-bit timer/counter
- bit 5 **T0CS:** Timer0 Clock Source Select bit
 1 = Transition on T0CKI pin
 0 = Internal instruction cycle clock (CLKO)
- bit 4 **T0SE:** Timer0 Source Edge Select bit
 1 = Increment on high-to-low transition on T0CKI pin
 0 = Increment on low-to-high transition on T0CKI pin
- bit 3 **PSA:** Timer0 Prescaler Assignment bit
 1 = Timer0 prescaler is NOT assigned. Timer0 clock input bypasses prescaler.
 0 = Timer0 prescaler is assigned. Timer0 clock input comes from prescaler output.
- bit 2-0 **T0PS2:T0PS0:** Timer0 Prescaler Select bits
 111 = 1:256 prescale value
 110 = 1:128 prescale value
 101 = 1:64 prescale value
 100 = 1:32 prescale value
 011 = 1:16 prescale value
 010 = 1:8 prescale value
 001 = 1:4 prescale value
 000 = 1:2 prescale value

Legend:

R = Readable bit	W = Writable bit	U = Unimplemented bit, read as '0'
- n = Value at POR	'1' = Bit is set	'0' = Bit is cleared x = Bit is unknown

PIC18F6520/8520/6620/8620/6720/8720

FIGURE 11-1: TIMER0 BLOCK DIAGRAM IN 8-BIT MODE

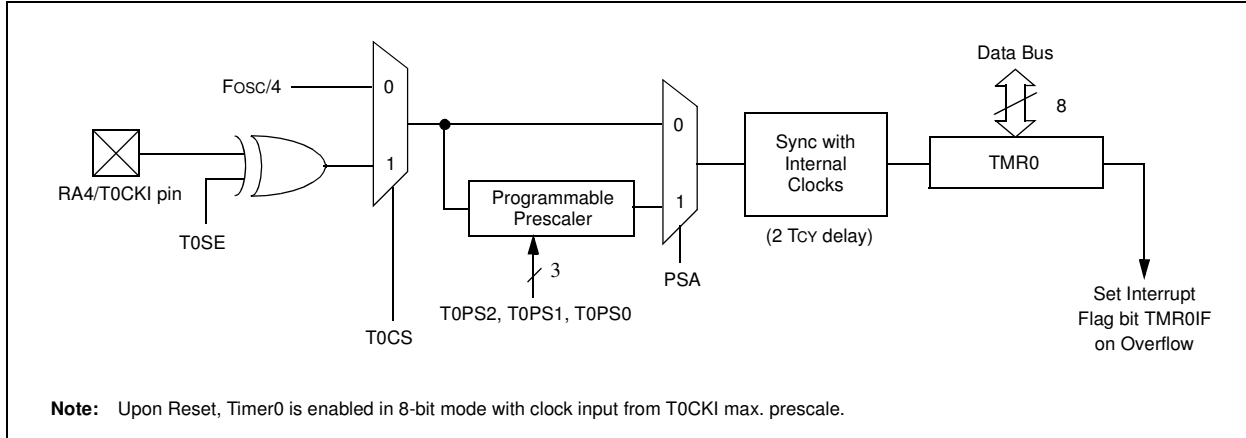
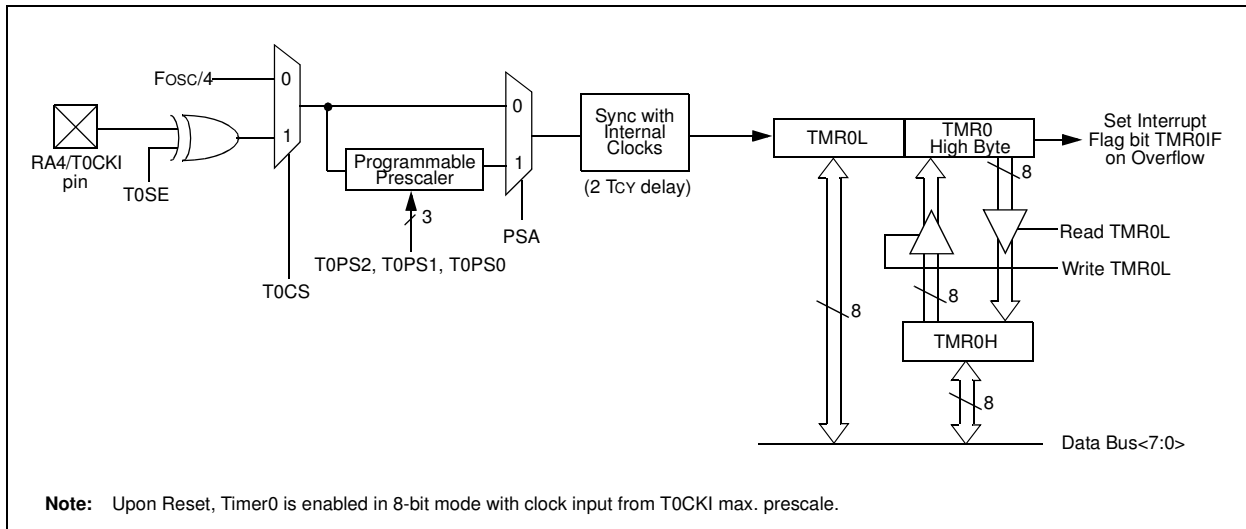

FIGURE 11-2: TIMER0 BLOCK DIAGRAM IN 16-BIT MODE



PIC18F6520/8520/6620/8620/6720/8720

11.1 Timer0 Operation

Timer0 can operate as a timer or as a counter.

Timer mode is selected by clearing the T0CS bit. In Timer mode, the Timer0 module will increment every instruction cycle (without prescaler). If the TMR0 register is written, the increment is inhibited for the following two instruction cycles. The user can work around this by writing an adjusted value to the TMR0 register.

Counter mode is selected by setting the T0CS bit. In Counter mode, Timer0 will increment, either on every rising or falling edge of pin RA4/T0CKI. The incrementing edge is determined by the Timer0 Source Edge Select bit (T0SE). Clearing the T0SE bit selects the rising edge. Restrictions on the external clock input are discussed below.

When an external clock input is used for Timer0, it must meet certain requirements. The requirements ensure the external clock can be synchronized with the internal phase clock (TOSC). Also, there is a delay in the actual incrementing of Timer0 after synchronization.

11.2 Prescaler

An 8-bit counter is available as a prescaler for the Timer0 module. The prescaler is not readable or writable.

The PSA and T0PS2:T0PS0 bits determine the prescaler assignment and prescale ratio.

Clearing bit PSA will assign the prescaler to the Timer0 module. When the prescaler is assigned to the Timer0 module, prescale values of 1:2, 1:4, ..., 1:256 are selectable.

When assigned to the Timer0 module, all instructions writing to the TMR0 register (e.g., CLRF TMR0, MOVWF TMR0, BSF TMR0, x, ..., etc.) will clear the prescaler count.

Note: Writing to TMR0 when the prescaler is assigned to Timer0, will clear the prescaler count, but will not change the prescaler assignment.

11.2.1 SWITCHING PRESCALER ASSIGNMENT

The prescaler assignment is fully under software control, (i.e., it can be changed “on-the-fly” during program execution).

11.3 Timer0 Interrupt

The TMR0 interrupt is generated when the TMR0 register overflows from FFh to 00h in 8-bit mode, or FFFFh to 0000h in 16-bit mode. This overflow sets the TMR0IF bit. The interrupt can be masked by clearing the TMR0IE bit. The TMR0IF bit must be cleared in software by the Timer0 module Interrupt Service Routine before re-enabling this interrupt. The TMR0 interrupt cannot awaken the processor from Sleep, since the timer is shut-off during Sleep.

11.4 16-Bit Mode Timer Reads and Writes

TMR0H is not the high byte of the timer/counter in 16-bit mode, but is actually a buffered version of the high byte of Timer0 (refer to Figure 11-2). The high byte of the Timer0 counter/timer is not directly readable nor writable. TMR0H is updated with the contents of the high byte of Timer0 during a read of TMR0L. This provides the ability to read all 16 bits of Timer0 without having to verify that the read of the high and low byte were valid, due to a rollover between successive reads of the high and low byte.

A write to the high byte of Timer0 must also take place through the TMR0H Buffer register. Timer0 high byte is updated with the contents of TMR0H when a write occurs to TMR0L. This allows all 16 bits of Timer0 to be updated at once.

TABLE 11-1: REGISTERS ASSOCIATED WITH TIMER0

Name	Bit 7	Bit 6	Bit 5	Bit 4	Bit 3	Bit 2	Bit 1	Bit 0	Value on POR, BOR	Value on all other Resets
TMR0L	Timer0 Module Low Byte Register								xxxx xxxx	uuuu uuuu
TMR0H	Timer0 Module High Byte Register								0000 0000	0000 0000
INTCON	GIE/GIEH	PEIE/GIEL	TMR0IE	INT0IE	RBIE	TMR0IF	INT0IF	RBIF	0000 0000	0000 0000
T0CON	TMR0ON	T08BIT	T0CS	T0SE	PSA	T0PS2	T0PS1	T0PS0	1111 1111	1111 1111
TRISA	—	PORTA Data Direction Register							-111 1111	-111 1111

Legend: x = unknown, u = unchanged, — = unimplemented locations, read as ‘0’.
Shaded cells are not used by Timer0.

PIC18F6520/8520/6620/8620/6720/8720

NOTES:

PIC18F6520/8520/6620/8620/6720/8720

12.0 TIMER1 MODULE

The Timer1 module timer/counter has the following features:

- 16-bit timer/counter (two 8-bit registers: TMR1H and TMR1L)
- Readable and writable (both registers)
- Internal or external clock select
- Interrupt-on-overflow from FFFFh to 0000h
- Reset from CCP module special event trigger

Figure 12-1 is a simplified block diagram of the Timer1 module.

Register 12-1 details the Timer1 Control register. This register controls the operating mode of the Timer1 module and contains the Timer1 Oscillator Enable bit (T1OSCEN). Timer1 can be enabled or disabled by setting or clearing control bit, TMR1ON (T1CON<0>).

Timer1 can also be used to provide Real-Time Clock (RTC) functionality to applications, with only a minimal addition of external components and code overhead.

REGISTER 12-1: T1CON: TIMER1 CONTROL REGISTER

R/W-0	U-0	R/W-0	R/W-0	R/W-0	R/W-0	R/W-0	R/W-0
RD16	—	T1CKPS1	T1CKPS0	T1OSCEN	T1SYNC	TMR1CS	TMR1ON
bit 7							bit 0

- bit 7 **RD16:** 16-bit Read/Write Mode Enable bit
 1 = Enables register read/write of Timer1 in one 16-bit operation
 0 = Enables register read/write of Timer1 in two 8-bit operations
- bit 6 **Unimplemented:** Read as '0'
- bit 5-4 **T1CKPS1:T1CKPS0:** Timer1 Input Clock Prescale Select bits
 11 = 1:8 Prescale value
 10 = 1:4 Prescale value
 01 = 1:2 Prescale value
 00 = 1:1 Prescale value
- bit 3 **T1OSCEN:** Timer1 Oscillator Enable bit
 1 = Timer1 oscillator is enabled
 0 = Timer1 oscillator is shut off
 The oscillator inverter and feedback resistor are turned off to eliminate power drain.
- bit 2 **T1SYNC:** Timer1 External Clock Input Synchronization Select bit
When TMR1CS = 1:
 1 = Do not synchronize external clock input
 0 = Synchronize external clock input
When TMR1CS = 0:
 This bit is ignored. Timer1 uses the internal clock when TMR1CS = 0.
- bit 1 **TMR1CS:** Timer1 Clock Source Select bit
 1 = External clock from pin RC0/T1OSO/T13CKI (on the rising edge)
 0 = Internal clock (FOSC/4)
- bit 0 **TMR1ON:** Timer1 On bit
 1 = Enables Timer1
 0 = Stops Timer1

Legend:

R = Readable bit	W = Writable bit	U = Unimplemented bit, read as '0'
- n = Value at POR	'1' = Bit is set	'0' = Bit is cleared x = Bit is unknown

PIC18F6520/8520/6620/8620/6720/8720

12.1 Timer1 Operation

Timer1 can operate in one of these modes:

- As a timer
- As a synchronous counter
- As an asynchronous counter

The operating mode is determined by the clock select bit, TMR1CS (T1CON<1>).

When TMR1CS = 0, Timer1 increments every instruction cycle. When TMR1CS = 1, Timer1 increments on every rising edge of the external clock input or the Timer1 oscillator, if enabled.

When the Timer1 oscillator is enabled (T1OSCEN is set), the RC1/T1OSI and RC0/T1OSO/T13CKI pins become inputs. That is, the TRISC<1:0> value is ignored and the pins are read as '0'.

Timer1 also has an internal "Reset input". This Reset can be generated by the CCP module (see Section 16.0 "Capture/Compare/PWM (CCP) Modules").

FIGURE 12-1: TIMER1 BLOCK DIAGRAM

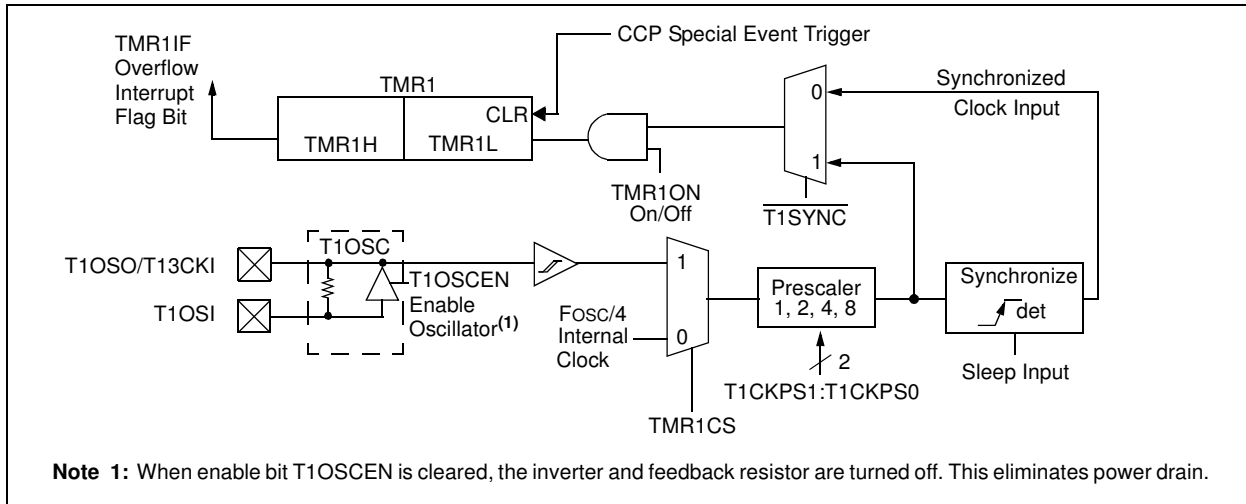
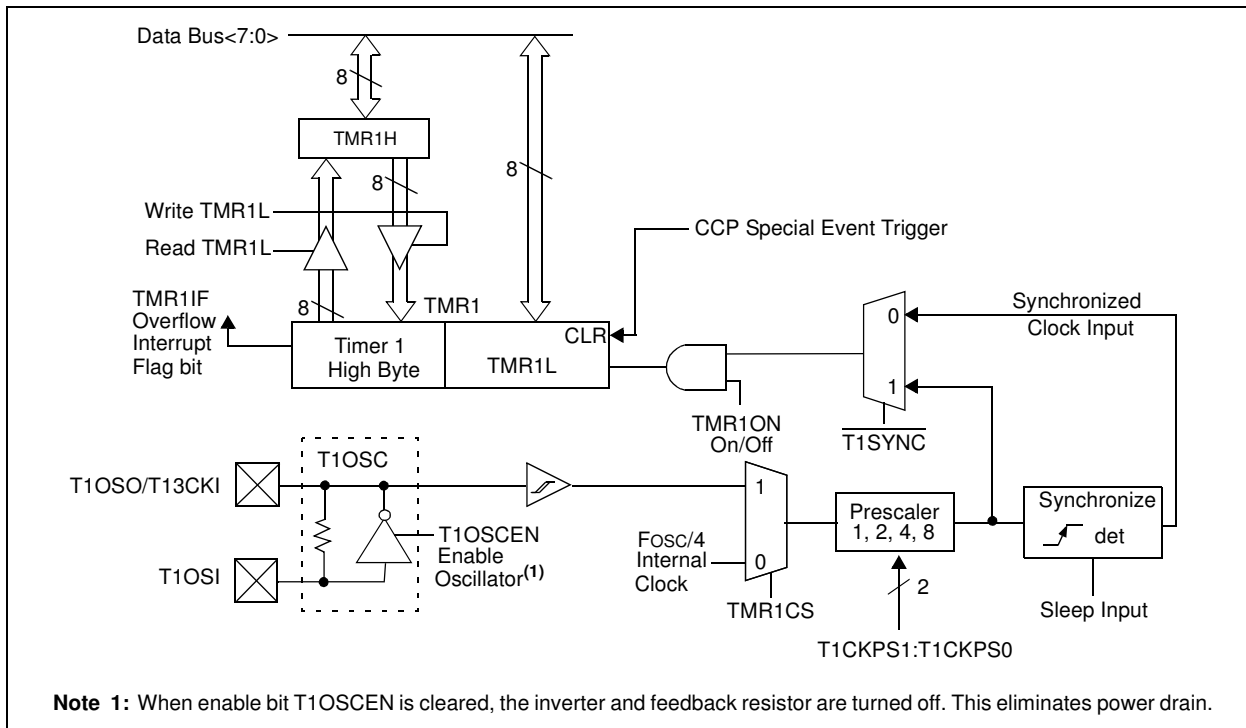

FIGURE 12-2: TIMER1 BLOCK DIAGRAM: 16-BIT READ/WRITE MODE



PIC18F6520/8520/6620/8620/6720/8720

12.2 Timer1 Oscillator

A crystal oscillator circuit is built-in between pins T1OSI (input) and T1OSO (amplifier output). It is enabled by setting control bit, T1OSCEN (T1CON<3>). The oscillator is a low-power oscillator, rated up to 200 kHz. It will continue to run during Sleep. It is primarily intended for a 32 kHz crystal. The circuit for a typical LP oscillator is shown in Figure 12-3. Table 12-1 shows the capacitor selection for the Timer1 oscillator.

The user must provide a software time delay to ensure proper start-up of the Timer1 oscillator

FIGURE 12-3: EXTERNAL COMPONENTS FOR THE TIMER1 LP OSCILLATOR

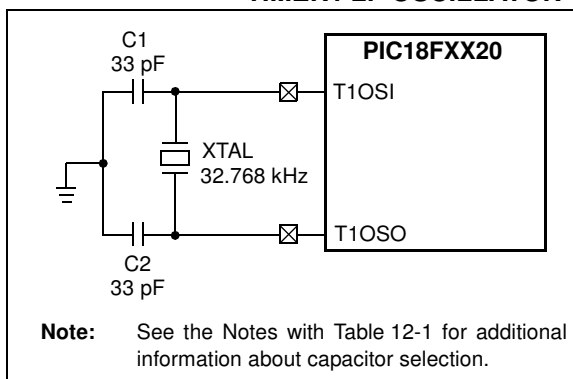

TABLE 12-1: CAPACITOR SELECTION FOR THE ALTERNATE OSCILLATOR

Osc Type	Freq	C1	C2
LP	32 kHz	TBD ⁽¹⁾	TBD ⁽¹⁾
Crystal to be Tested:			
32.768 kHz	Epson C-001R32.768K-A	± 20 PPM	

Note 1: Microchip suggests 33 pF as a starting point in validating the oscillator circuit.

- 2: Higher capacitance increases the stability of the oscillator, but also increases the start-up time.
- 3: Since each resonator/crystal has its own characteristics, the user should consult the resonator/crystal manufacturer for appropriate values of external components.
- 4: Capacitor values are for design guidance only.

12.2.1 LOW-POWER TIMER1 OPTION (PIC18FX520 DEVICES ONLY)

The Timer1 oscillator for PIC18LFX520 devices incorporates a low-power feature, which allows the oscillator to automatically reduce its power consumption when the microcontroller is in Sleep mode.

As high noise environments may cause excessive oscillator instability in Sleep mode, this option is best suited for low noise applications where power conservation is an important design consideration. Due to the low-power nature of the oscillator, it may also be sensitive to rapidly changing signals in close proximity.

The oscillator circuit, shown in Figure 12-3, should be located as close as possible to the microcontroller. There should be no circuits passing within the oscillator circuit boundaries other than Vss or VDD.

If a high-speed circuit must be located near the oscillator (such as the CCP1 pin in output compare or PWM mode, or the primary oscillator using the OSC2 pin), a grounded guard ring around the oscillator circuit, as shown in Figure 12-4, may be helpful when used on a single-sided PCB or in addition to a ground plane.

FIGURE 12-4: OSCILLATOR CIRCUIT WITH GROUNDED GUARD RING

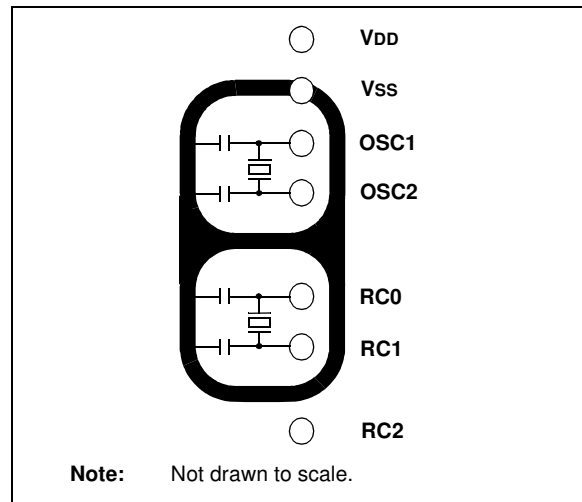

Note: PIC18FX620/X720 devices have the standard Timer1 oscillator permanently selected. PIC18LFX620/X720 devices have the low-power Timer1 oscillator permanently selected.

PIC18F6520/8520/6620/8620/6720/8720

12.3 Timer1 Interrupt

The TMR1 register pair (TMR1H:TMR1L) increments from 0000h to FFFFh and rolls over to 0000h. The TMR1 interrupt, if enabled, is generated on overflow, which is latched in interrupt flag bit, TMR1IF (PIR1<0>). This interrupt can be enabled/disabled by setting/clearing TMR1 Interrupt Enable bit, TMR1IE (PIE1<0>).

12.4 Resetting Timer1 Using a CCP Trigger Output

If the CCP module is configured in Compare mode to generate a “special event trigger” (CCP1M3:CCP1M0 = 1011), this signal will reset Timer1 and start an A/D conversion (if the A/D module is enabled).

Note: The special event triggers from the CCP1 module will not set interrupt flag bit TMR1IF (PIR1<0>).

Timer1 must be configured for either Timer or Synchronized Counter mode to take advantage of this feature. If Timer1 is running in Asynchronous Counter mode, this Reset operation may not work.

In the event that a write to Timer1 coincides with a special event trigger from CCP1, the write will take precedence.

In this mode of operation, the CCPR1H:CCPR1L register pair effectively becomes the period register for Timer1.

12.5 Timer1 16-Bit Read/Write Mode

Timer1 can be configured for 16-bit reads and writes (see Figure 12-2). When the RD16 control bit (T1CON<7>) is set, the address for TMR1H is mapped to a buffer register for the high byte of Timer1. A read from TMR1L will load the contents of the high byte of Timer1 into the Timer1 high byte buffer. This provides the user with the ability to accurately read all 16 bits of Timer1 without having to determine whether a read of the high byte, followed by a read of the low byte, is valid, due to a rollover between reads.

A write to the high byte of Timer1 must also take place through the TMR1H Buffer register. Timer1 high byte is updated with the contents of TMR1H when a write occurs to TMR1L. This allows a user to write all 16 bits to both the high and low bytes of Timer1 at once.

The high byte of Timer1 is not directly readable or writable in this mode. All reads and writes must take place through the Timer1 High Byte Buffer register. Writes to TMR1H do not clear the Timer1 prescaler. The prescaler is only cleared on writes to TMR1L.

12.6 Using Timer1 as a Real-Time Clock

Adding an external LP oscillator to Timer1 (such as the one described in **Section 12.2 “Timer1 Oscillator”**) gives users the option to include RTC functionality to their applications. This is accomplished with an inexpensive watch crystal to provide an accurate time base and several lines of application code to calculate the time. When operating in Sleep mode and using a battery or supercapacitor as a power source, it can completely eliminate the need for a separate RTC device and battery backup.

The application code routine, *RTCISR*, shown in Example 12-1, demonstrates a simple method to increment a counter at one-second intervals using an Interrupt Service Routine. Incrementing the TMR1 register pair to overflow, triggers the interrupt and calls the routine, which increments the seconds counter by one; additional counters for minutes and hours are incremented as the previous counter overflows.

Since the register pair is 16 bits wide, counting up to overflow the register directly from a 32.768 kHz clock would take 2 seconds. To force the overflow at the required one-second intervals, it is necessary to preload it; the simplest method is to set the MSb of TMR1H with a BSF instruction. Note that the TMR1L register is never preloaded or altered; doing so may introduce cumulative error over many cycles.

For this method to be accurate, Timer1 must operate in Asynchronous mode and the Timer1 overflow interrupt must be enabled (PIE1<0> = 1), as shown in the routine, *RTCinit*. The Timer1 oscillator must also be enabled and running at all times.

PIC18F6520/8520/6620/8620/6720/8720

EXAMPLE 12-1: IMPLEMENTING A REAL-TIME CLOCK USING A TIMER1 INTERRUPT SERVICE

```

RTCinit
    MOVLW    0x80          ; Preload TMR1 register pair
    MOVWF    TMR1H        ; for 1 second overflow
    CLRF     TMR1L
    MOVLW    b'00001111'  ; Configure for external clock,
    MOVWF    T1OSC        ; Asynchronous operation, external oscillator
    CLRF     secs         ; Initialize timekeeping registers
    CLRF     mins         ;
    MOVLW    .12
    MOVWF    hours
    BSF      PIE1, TMR1IE ; Enable Timer1 interrupt
    RETURN

RTCisr
    BSF      TMR1H, 7     ; Preload for 1 sec overflow
    BCF      PIR1, TMR1IF ; Clear interrupt flag
    INCF     secs, F      ; Increment seconds
    MOVLW    .59         ; 60 seconds elapsed?
    CPFSGT   secs
    RETURN    ; No, done
    CLRF     secs        ; Clear seconds
    INCF     mins, F     ; Increment minutes
    MOVLW    .59         ; 60 minutes elapsed?
    CPFSGT   mins
    RETURN    ; No, done
    CLRF     mins        ; clear minutes
    INCF     hours, F    ; Increment hours
    MOVLW    .23         ; 24 hours elapsed?
    CPFSGT   hours
    RETURN    ; No, done
    MOVLW    .01         ; Reset hours to 1
    MOVWF    hours
    RETURN    ; Done
    
```

TABLE 12-2: REGISTERS ASSOCIATED WITH TIMER1 AS A TIMER/COUNTER

Name	Bit 7	Bit 6	Bit 5	Bit 4	Bit 3	Bit 2	Bit 1	Bit 0	Value on POR, BOR	Value on all other Resets
INTCON	GIE/GIEH	PEIE/GIEL	TMR0IE	INT0IE	RBIE	TMR0IF	INT0IF	RBIF	0000 0000	0000 0000
PIR1	PSPIF	ADIF	RCIF	TXIF	SSPIF	CCP1IF	TMR2IF	TMR1IF	0000 0000	0000 0000
PIE1	PSPIE	ADIE	RCIE	TXIE	SSPIE	CCP1IE	TMR2IE	TMR1IE	0000 0000	0000 0000
IPR1	PSPIP	ADIP	RCIP	TXIP	SSPIP	CCP1IP	TMR2IP	TMR1IP	0111 1111	0111 1111
TMR1L	Holding Register for the Least Significant Byte of the 16-bit TMR1 Register								xxxx xxxx	uuuu uuuu
TMR1H	Holding Register for the Most Significant Byte of the 16-bit TMR1 Register								xxxx xxxx	uuuu uuuu
T1CON	RD16	—	T1CKPS1	T1CKPS0	T1OSCEN	T1SYNC	TMR1CS	TMR1ON	0-00 0000	u-uu uuuu

Legend: x = unknown, u = unchanged, — = unimplemented, read as '0'. Shaded cells are not used by the Timer1 module.

PIC18F6520/8520/6620/8620/6720/8720

NOTES:

PIC18F6520/8520/6620/8620/6720/8720

13.0 TIMER2 MODULE

The Timer2 module timer has the following features:

- 8-bit timer (TMR2 register)
- 8-bit period register (PR2)
- Readable and writable (both registers)
- Software programmable prescaler (1:1, 1:4, 1:16)
- Software programmable postscaler (1:1 to 1:16)
- Interrupt on TMR2 match of PR2
- SSP module optional use of TMR2 output to generate clock shift

Timer2 has a control register shown in Register 13-1. Timer2 can be shut-off by clearing control bit, TMR2ON (T2CON<2>), to minimize power consumption. Figure 13-1 is a simplified block diagram of the Timer2 module. Register 13-1 shows the Timer2 Control register. The prescaler and postscaler selection of Timer2 are controlled by this register.

13.1 Timer2 Operation

Timer2 can be used as the PWM time base for the PWM mode of the CCP module. The TMR2 register is readable and writable and is cleared on any device Reset. The input clock ($F_{OSC}/4$) has a prescale option of 1:1, 1:4 or 1:16, selected by control bits, T2CKPS1:T2CKPS0 (T2CON<1:0>). The match output of TMR2 goes through a 4-bit postscaler (which gives a 1:1 to 1:16 scaling inclusive) to generate a TMR2 interrupt (latched in flag bit, TMR2IF (PIR1<1>)).

The prescaler and postscaler counters are cleared when any of the following occurs:

- a write to the TMR2 register
- a write to the T2CON register
- any device Reset (Power-on Reset, \overline{MCLR} Reset, Watchdog Timer Reset or Brown-out Reset)

TMR2 is not cleared when T2CON is written.

REGISTER 13-1: T2CON: TIMER2 CONTROL REGISTER

U-0	R/W-0	R/W-0	R/W-0	R/W-0	R/W-0	R/W-0	R/W-0
—	T2OUTPS3	T2OUTPS2	T2OUTPS1	T2OUTPS0	TMR2ON	T2CKPS1	T2CKPS0
bit 7							bit 0

- bit 7 **Unimplemented:** Read as '0'
- bit 6-3 **T2OUTPS3:T2OUTPS0:** Timer2 Output Postscale Select bits
 0000 = 1:1 Postscale
 0001 = 1:2 Postscale
 •
 •
 •
 1111 = 1:16 Postscale
- bit 2 **TMR2ON:** Timer2 On bit
 1 = Timer2 is on
 0 = Timer2 is off
- bit 1-0 **T2CKPS1:T2CKPS0:** Timer2 Clock Prescale Select bits
 00 = Prescaler is 1
 01 = Prescaler is 4
 1x = Prescaler is 16

Legend:

R = Readable bit	W = Writable bit	U = Unimplemented bit, read as '0'
- n = Value at POR	'1' = Bit is set	'0' = Bit is cleared x = Bit is unknown

PIC18F6520/8520/6620/8620/6720/8720

13.2 Timer2 Interrupt

The Timer2 module has an 8-bit period register, PR2. Timer2 increments from 00h until it matches PR2 and then resets to 00h on the next increment cycle. PR2 is a readable and writable register. The PR2 register is initialized to FFh upon Reset.

13.3 Output of TMR2

The output of TMR2 (before the postscaler) is fed to the synchronous serial port module, which optionally uses it to generate the shift clock.

FIGURE 13-1: TIMER2 BLOCK DIAGRAM

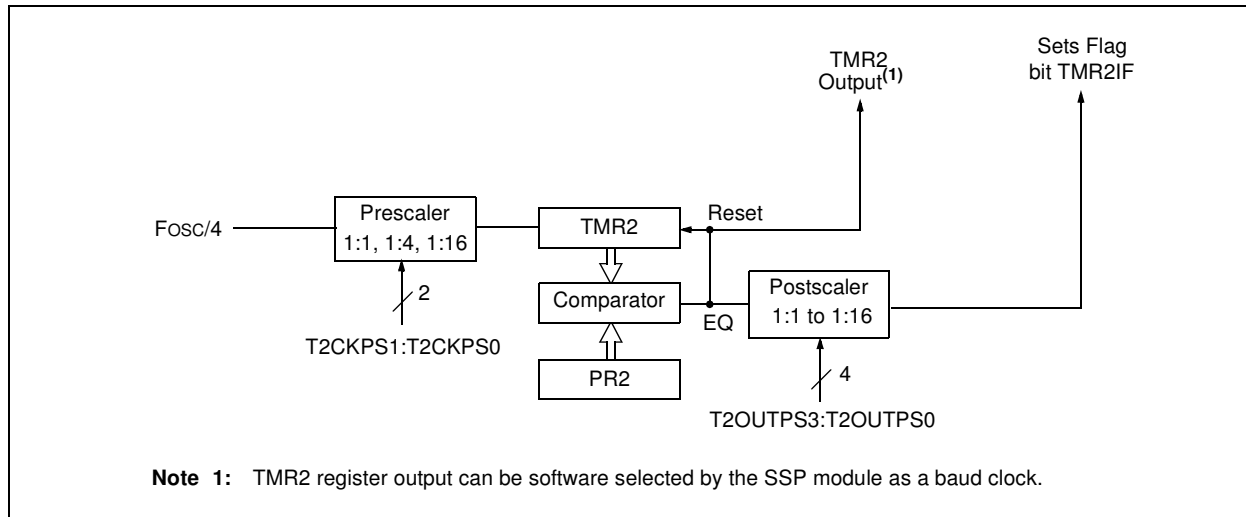

TABLE 13-1: REGISTERS ASSOCIATED WITH TIMER2 AS A TIMER/COUNTER

Name	Bit 7	Bit 6	Bit 5	Bit 4	Bit 3	Bit 2	Bit 1	Bit 0	Value on POR, BOR	Value on all other Resets
INTCON	GIE/GIEH	PEIE/GIEL	TMR0IE	INT0IE	RBIE	TMR0IF	INT0IF	RBIF	0000 0000	0000 0000
PIR1	PSPIF	ADIF	RCIF	TXIF	SSPIF	CCP1IF	TMR2IF	TMR1IF	0000 0000	0000 0000
PIE1	PSPIE	ADIE	RCIE	TXIE	SSPIE	CCP1IE	TMR2IE	TMR1IE	0000 0000	0000 0000
IPR1	PSPIP	ADIP	RCIP	TXIP	SSPIP	CCP1IP	TMR2IP	TMR1IP	0111 1111	0111 1111
TMR2	Timer2 Module Register								0000 0000	0000 0000
T2CON	—	T2OUTPS3	T2OUTPS2	T2OUTPS1	T2OUTPS0	TMR2ON	T2CKPS1	T2CKPS0	-000 0000	-000 0000
PR2	Timer2 Period Register								1111 1111	1111 1111

Legend: x = unknown, u = unchanged, - = unimplemented, read as '0'. Shaded cells are not used by the Timer2 module.

PIC18F6520/8520/6620/8620/6720/8720

14.0 TIMER3 MODULE

The Timer3 module timer/counter has the following features:

- 16-bit timer/counter (two 8-bit registers; TMR3H and TMR3L)
- Readable and writable (both registers)
- Internal or external clock select
- Interrupt-on-overflow from FFFFh to 0000h
- Reset from CCP module trigger

Figure 14-1 is a simplified block diagram of the Timer3 module.

Register 14-1 shows the Timer3 Control register. This register controls the operating mode of the Timer3 module and sets the CCP clock source.

Register 12-1 shows the Timer1 Control register. This register controls the operating mode of the Timer1 module, as well as contains the Timer1 Oscillator Enable bit (T1OSCEN), which can be a clock source for Timer3.

REGISTER 14-1: T3CON: TIMER3 CONTROL REGISTER

R/W-0	R/W-0	R/W-0	R/W-0	R/W-0	R/W-0	R/W-0	R/W-0
RD16	T3CCP2	T3CKPS1	T3CKPS0	T3CCP1	T3SYNC	TMR3CS	TMR3ON
bit 7							bit 0

- bit 7 **RD16:** 16-bit Read/Write Mode Enable bit
 1 = Enables register read/write of Timer3 in one 16-bit operation
 0 = Enables register read/write of Timer3 in two 8-bit operations
- bit 6, 3 **T3CCP2:T3CCP1:** Timer3 and Timer1 to CCPx Enable bits
 11 = Timer3 and Timer4 are the clock sources for CCP1 through CCP5
 10 = Timer3 and Timer4 are the clock sources for CCP3 through CCP5;
 Timer1 and Timer2 are the clock sources for CCP1 and CCP2
 01 = Timer3 and Timer4 are the clock sources for CCP2 through CCP5;
 Timer1 and Timer2 are the clock sources for CCP1
 00 = Timer1 and Timer2 are the clock sources for CCP1 through CCP5
- bit 5-4 **T3CKPS1:T3CKPS0:** Timer3 Input Clock Prescale Select bits
 11 = 1:8 Prescale value
 10 = 1:4 Prescale value
 01 = 1:2 Prescale value
 00 = 1:1 Prescale value
- bit 2 **T3SYNC:** Timer3 External Clock Input Synchronization Control bit
 (Not usable if the system clock comes from Timer1/Timer3.)
When TMR3CS = 1:
 1 = Do not synchronize external clock input
 0 = Synchronize external clock input
When TMR3CS = 0:
 This bit is ignored. Timer3 uses the internal clock when TMR3CS = 0.
- bit 1 **TMR3CS:** Timer3 Clock Source Select bit
 1 = External clock input from Timer1 oscillator or T13CKI (on the rising edge after the first falling edge)
 0 = Internal clock (Fosc/4)
- bit 0 **TMR3ON:** Timer3 On bit
 1 = Enables Timer3
 0 = Stops Timer3

Legend:

R = Readable bit	W = Writable bit	U = Unimplemented bit, read as '0'
- n = Value at POR	'1' = Bit is set	'0' = Bit is cleared x = Bit is unknown

PIC18F6520/8520/6620/8620/6720/8720

14.1 Timer3 Operation

Timer3 can operate in one of these modes:

- As a timer
- As a synchronous counter
- As an asynchronous counter

The operating mode is determined by the clock select bit, TMR3CS (T3CON<1>).

When TMR3CS = 0, Timer3 increments every instruction cycle. When TMR3CS = 1, Timer3 increments on every rising edge of the Timer1 external clock input or the Timer1 oscillator, if enabled.

When the Timer1 oscillator is enabled (T1OSCEN is set), the RC1/T1OSI and RC0/T1OSO/T13CKI pins become inputs. That is, the TRISC<1:0> value is ignored and the pins are read as '0'.

Timer3 also has an internal "Reset input". This Reset can be generated by the CCP module (see **Section 14.0 "Timer3 Module"**).

FIGURE 14-1: TIMER3 BLOCK DIAGRAM

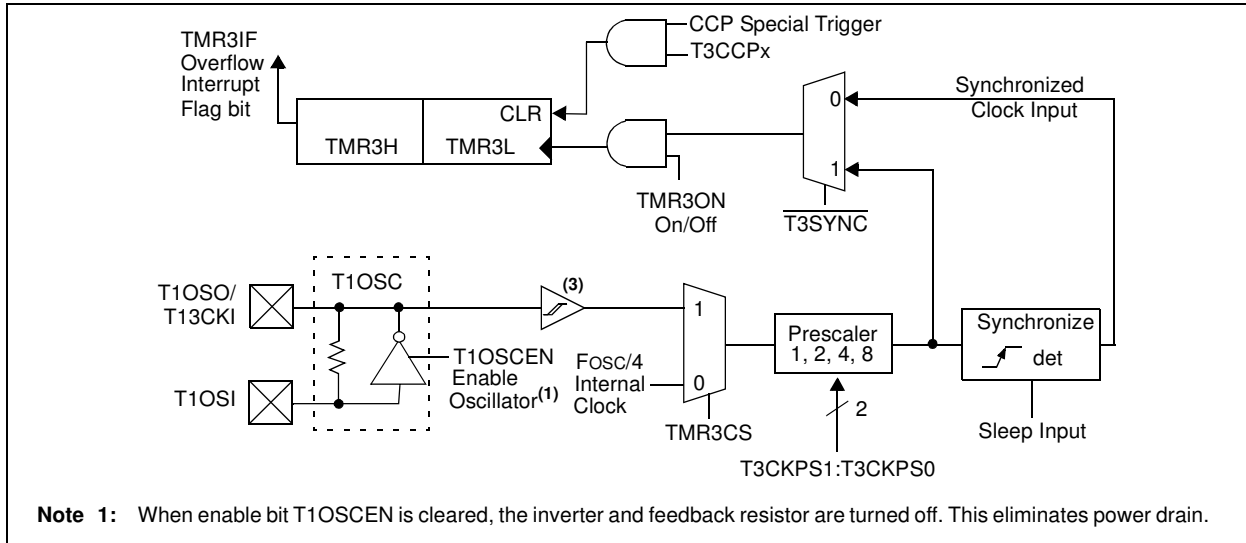
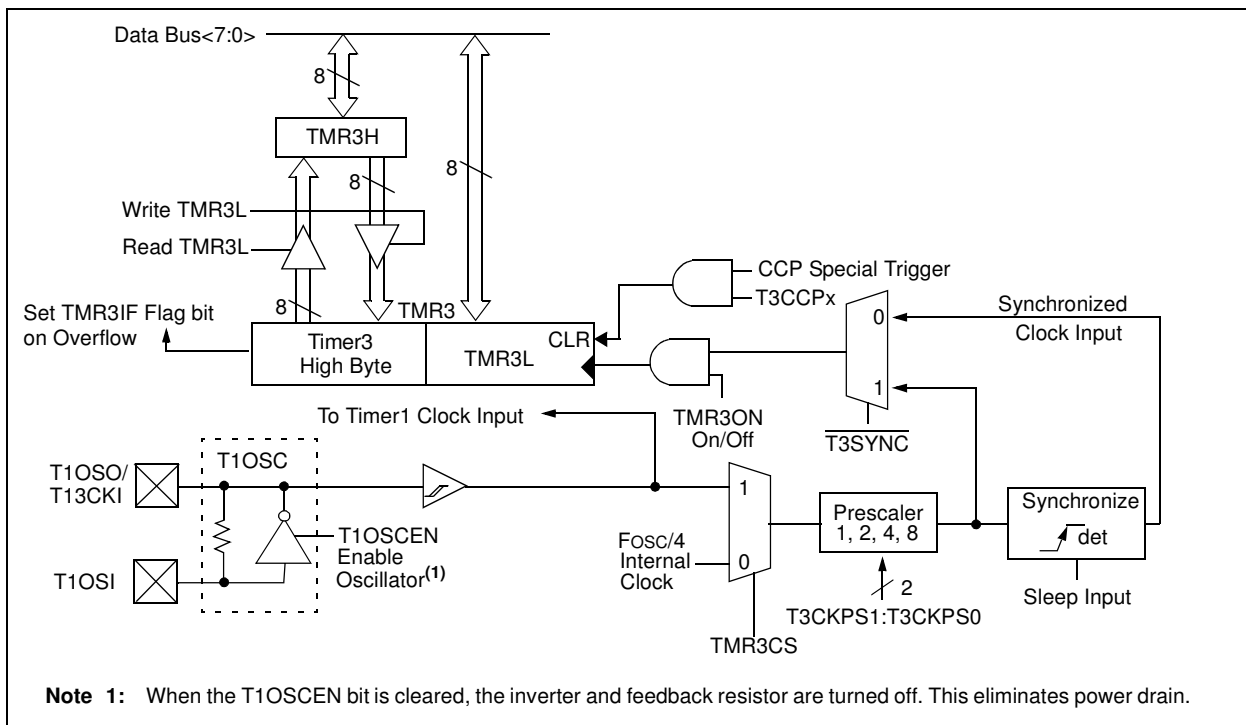

FIGURE 14-2: TIMER3 BLOCK DIAGRAM CONFIGURED IN 16-BIT READ/WRITE MODE



PIC18F6520/8520/6620/8620/6720/8720

14.2 Timer1 Oscillator

The Timer1 oscillator may be used as the clock source for Timer3. The Timer1 oscillator is enabled by setting the T1OSCEN (T1CON<3>) bit. The oscillator is a low-power oscillator rated up to 200 kHz. See **Section 12.0 “Timer1 Module”** for further details.

14.3 Timer3 Interrupt

The TMR3 register pair (TMR3H:TMR3L) increments from 0000h to FFFFh and rolls over to 0000h. The TMR3 interrupt, if enabled, is generated on overflow, which is latched in interrupt flag bit, TMR3IF (PIR2<1>). This interrupt can be enabled/disabled by setting/clearing TMR3 Interrupt Enable bit, TMR3IE (PIE2<1>).

14.4 Resetting Timer3 Using a CCP Trigger Output

If the CCP module is configured in Compare mode to generate a “special event trigger” (CCP1M3:CCP1M0 = 1011), this signal will reset Timer3.

Note: The special event triggers from the CCP module will not set interrupt flag bit, TMR3IF (PIR1<0>).

Timer3 must be configured for either Timer or Synchronized Counter mode to take advantage of this feature. If Timer3 is running in Asynchronous Counter mode, this Reset operation may not work. In the event that a write to Timer3 coincides with a special event trigger from CCP1, the write will take precedence. In this mode of operation, the CCPR1H:CCPR1L register pair effectively becomes the period register for Timer3.

TABLE 14-1: REGISTERS ASSOCIATED WITH TIMER3 AS A TIMER/COUNTER

Name	Bit 7	Bit 6	Bit 5	Bit 4	Bit 3	Bit 2	Bit 1	Bit 0	Value on POR, BOR	Value on all other Resets
INTCON	GIE/GIEH	PEIE/GIEL	TMR0IE	INT0IE	RBIE	TMR0IF	INT0IF	RBIF	0000 0000	0000 0000
PIR2	—	—	—	EEIF	BCLIF	LVDIF	TMR3IF	CCP2IF	---0 0000	---0 0000
PIE2	—	—	—	EEIE	BCLIE	LVDIE	TMR3IE	CCP2IE	---0 0000	---0 0000
IPR2	—	—	—	EEIP	BCLIP	LVDIP	TMR3IP	CCP2IP	---1 1111	---1 1111
TMR3L	Holding Register for the Least Significant Byte of the 16-bit TMR3 Register								xxxx xxxx	uuuu uuuu
TMR3H	Holding Register for the Most Significant Byte of the 16-bit TMR3 Register								xxxx xxxx	uuuu uuuu
T1CON	RD16	—	T1CKPS1	T1CKPS0	T1OSCEN	$\overline{T1SYN\overline{C}}$	TMR1CS	TMR1ON	0-00 0000	u-uu uuuu
T3CON	RD16	T3CCP2	T3CKPS1	T3CKPS0	T3CCP1	$\overline{T3SYN\overline{C}}$	TMR3CS	TMR3ON	0000 0000	uuuu uuuu

Legend: x = unknown, u = unchanged, - = unimplemented, read as '0'. Shaded cells are not used by the Timer3 module.

PIC18F6520/8520/6620/8620/6720/8720

NOTES:

PIC18F6520/8520/6620/8620/6720/8720

15.0 TIMER4 MODULE

The Timer4 module timer has the following features:

- 8-bit timer (TMR4 register)
- 8-bit period register (PR4)
- Readable and writable (both registers)
- Software programmable prescaler (1:1, 1:4, 1:16)
- Software programmable postscaler (1:1 to 1:16)
- Interrupt on TMR4 match of PR4

Timer4 has a control register shown in Register 15-1. Timer4 can be shut-off by clearing control bit, TMR4ON (T4CON<2>), to minimize power consumption. The prescaler and postscaler selection of Timer4 are also controlled by this register. Figure 15-1 is a simplified block diagram of the Timer4 module.

15.1 Timer4 Operation

Timer4 can be used as the PWM time base for the PWM mode of the CCP module. The TMR4 register is readable and writable and is cleared on any device Reset. The input clock (FOSC/4) has a prescale option of 1:1, 1:4 or 1:16, selected by control bits T4CKPS1:T4CKPS0 (T4CON<1:0>). The match output of TMR4 goes through a 4-bit postscaler (which gives a 1:1 to 1:16 scaling inclusive) to generate a TMR4 interrupt, latched in flag bit, TMR4IF (PIR3<3>).

The prescaler and postscaler counters are cleared when any of the following occurs:

- a write to the TMR4 register
- a write to the T4CON register
- any device Reset (Power-on Reset, $\overline{\text{MCLR}}$ Reset, Watchdog Timer Reset or Brown-out Reset)

TMR4 is not cleared when T4CON is written.

REGISTER 15-1: T4CON: TIMER4 CONTROL REGISTER

U-0	R/W-0	R/W-0	R/W-0	R/W-0	R/W-0	R/W-0	R/W-0
—	T4OUTPS3	T4OUTPS2	T4OUTPS1	T4OUTPS0	TMR4ON	T4CKPS1	T4CKPS0
bit 7							bit 0

bit 7 **Unimplemented:** Read as '0'

bit 6-3 **T4OUTPS3:T4OUTPS0:** Timer4 Output Postscale Select bits

0000 = 1:1 Postscale

0001 = 1:2 Postscale

•

•

•

1111 = 1:16 Postscale

bit 2 **TMR4ON:** Timer4 On bit

1 = Timer4 is on

0 = Timer4 is off

bit 1-0 **T4CKPS1:T4CKPS0:** Timer4 Clock Prescale Select bits

00 = Prescaler is 1

01 = Prescaler is 4

1x = Prescaler is 16

Legend:

R = Readable bit

W = Writable bit

U = Unimplemented bit, read as '0'

- n = Value at POR

'1' = Bit is set

'0' = Bit is cleared

x = Bit is unknown

PIC18F6520/8520/6620/8620/6720/8720

15.2 Timer4 Interrupt

The Timer4 module has an 8-bit period register, PR4, which is both readable and writable. Timer4 increments from 00h until it matches PR4 and then resets to 00h on the next increment cycle. The PR4 register is initialized to FFh upon Reset.

15.3 Output of TMR4

The output of TMR4 (before the postscaler) is used only as a PWM time base for the CCP modules. It is not used as a baud rate clock for the MSSP, as is the Timer2 output.

FIGURE 15-1: TIMER4 BLOCK DIAGRAM

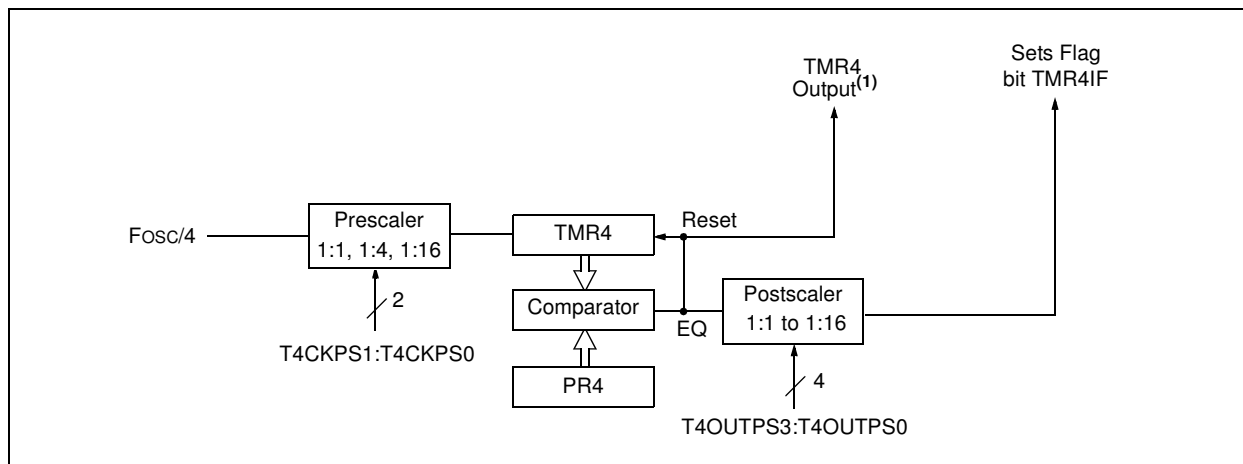

TABLE 15-1: REGISTERS ASSOCIATED WITH TIMER4 AS A TIMER/COUNTER

Name	Bit 7	Bit 6	Bit 5	Bit 4	Bit 3	Bit 2	Bit 1	Bit 0	Value on POR, BOR	Value on all other Resets
INTCON	GIE/GIEH	PEIE/GIEL	TMR0IE	INT0IE	RBIE	TMR0IF	INT0IF	RBIF	0000 0000	0000 0000
IPR3	—	—	RC2IP	TX2IP	TMR4IP	CCP5IP	CCP4IP	CCP3IP	--11 1111	--00 0000
PIR3	—	—	RC2IF	TX2IF	TMR4IF	CCP5IF	CCP4IF	CCP3IF	--00 0000	--00 0000
PIE3	—	—	RC2IE	TX2IE	TMR4IE	CCP5IE	CCP4IE	CCP3IE	--00 0000	--00 0000
TMR4	Timer4 Module Register								0000 0000	0000 0000
T4CON	—	T4OUTPS3	T4OUTPS2	T4OUTPS1	T4OUTPS0	TMR4ON	T4CKPS1	T4CKPS0	-000 0000	-000 0000
PR4	Timer4 Period Register								1111 1111	1111 1111

Legend: x = unknown, u = unchanged, - = unimplemented, read as '0'. Shaded cells are not used by the Timer4 module.

PIC18F6520/8520/6620/8620/6720/8720

16.0 CAPTURE/COMPARE/PWM (CCP) MODULES

The PIC18FXX20 devices all have five CCP (Capture/Compare/PWM) modules. Each module contains a 16-bit register, which can operate as a 16-bit Capture register, a 16-bit Compare register or a Pulse Width Modulation (PWM) Master/Slave Duty Cycle register. Table 16-1 shows the timer resources of the CCP module modes.

The operation of all CCP modules are identical, with the exception of the special event trigger present on CCP1 and CCP2.

For the sake of clarity, CCP module operation in the following sections is described with respect to CCP1. The descriptions can be applied (with the exception of the special event triggers) to any of the modules.

Note: Throughout this section, references to register and bit names that may be associated with a specific CCP module are referred to generically by the use of 'x' or 'y' in place of the specific module number. Thus, "CCPxCON" might refer to the control register for CCP1, CCP2, CCP3, CCP4 or CCP5.

REGISTER 16-1: CCPxCON REGISTER

	U-0	U-0	R/W-0	R/W-0	R/W-0	R/W-0	R/W-0	R/W-0
	—	—	DCxB1	DCxB0	CCPxM3	CCPxM2	CCPxM1	CCPxM0
bit 7								bit 0

bit 7-6 **Unimplemented:** Read as '0'

bit 5-4 **DCxB1:DCxB0:** PWM Duty Cycle bit 1 and bit 0 for CCP Module x

Capture mode:

Unused.

Compare mode:

Unused.

PWM mode:

These bits are the two Least Significant bits (bit 1 and bit 0) of the 10-bit PWM duty cycle. The eight Most Significant bits (DCx9:DCx2) of the duty cycle are found in CCPxL.

bit 3-0 **CCPxM3:CCPxM0:** CCP Module x Mode Select bits

0000 = Capture/Compare/PWM disabled (resets CCPx module)

0001 = Reserved

0010 = Compare mode, toggle output on match (CCPxIF bit is set)

0011 = Reserved

0100 = Capture mode, every falling edge

0101 = Capture mode, every rising edge

0110 = Capture mode, every 4th rising edge

0111 = Capture mode, every 16th rising edge

1000 = Compare mode, Initialize CCP pin Low; on compare match, force CCP pin High (CCPIF bit is set)

1001 = Compare mode, Initialize CCP pin High; on compare match, force CCP pin Low (CCPIF bit is set)

1010 = Compare mode, Generate software interrupt on compare match (CCPIF bit is set, CCP pin is unaffected)

1011 = Compare mode, trigger special event (CCPIF bit is set):

For CCP1 and CCP2:

Timer1 or Timer3 is reset on event.

For all other modules:

CCPx pin is unaffected and is configured as an I/O port (same as CCPxM<3:0> = 1010, above).

11xx = PWM mode

Legend:

R = Readable bit

W = Writable bit

U = Unimplemented bit, read as '0'

- n = Value at POR

'1' = Bit is set

'0' = Bit is cleared

x = Bit is unknown

PIC18F6520/8520/6620/8620/6720/8720

16.1 CCP Module Configuration

Each Capture/Compare/PWM module is associated with a control register (generally, CCPxCON) and a data register (CCPRx). The data register, in turn, is comprised of two 8-bit registers: CCPRxL (low byte) and CCPRxH (high byte). All registers are both readable and writable.

16.1.1 CCP MODULES AND TIMER RESOURCES

The CCP modules utilize Timers 1, 2, 3 or 4, depending on the mode selected. Timer1 and Timer3 are available to modules in Capture or Compare modes, while Timer2 and Timer4 are available for modules in PWM mode.

TABLE 16-1: CCP MODE – TIMER RESOURCE

CCP Mode	Timer Resource
Capture	Timer1 or Timer3
Compare	Timer1 or Timer3
PWM	Timer2 or Timer4

The assignment of a particular timer to a module is determined by the Timer-to-CCP Enable bits in the T3CON register (Register 14-1). Depending on the configuration selected, up to four timers may be active at once, with modules in the same configuration (Capture/Compare or PWM) sharing timer resources. The possible configurations are shown in Figure 16-1.

FIGURE 16-1: CCP AND TIMER INTERCONNECT CONFIGURATIONS

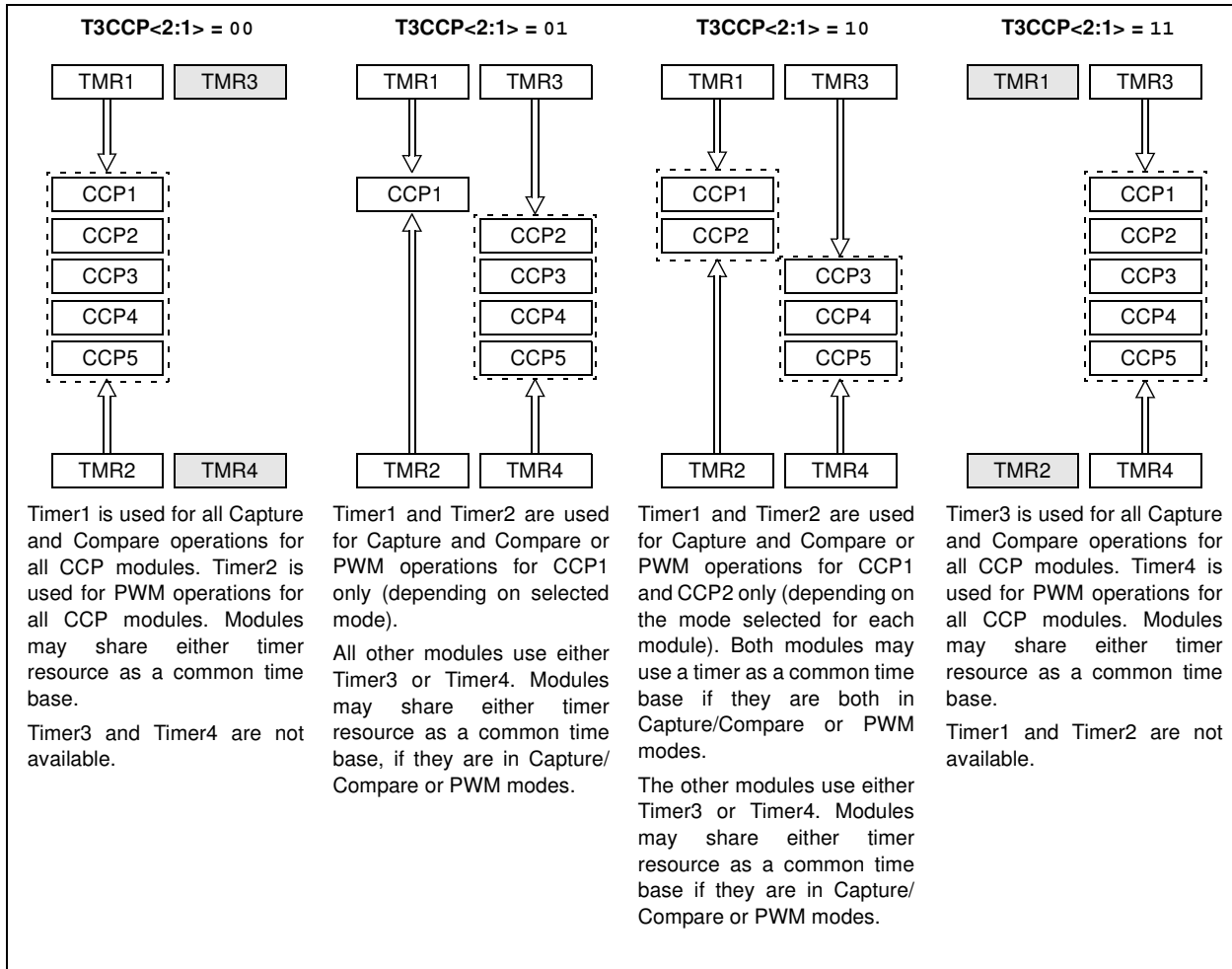

PIC18F6520/8520/6620/8620/6720/8720

16.2 Capture Mode

In Capture mode, CCP1H:CCP1L captures the 16-bit value of the TMR1 or TMR3 registers when an event occurs on pin RC2/CCP1. An event is defined as one of the following:

- every falling edge
- every rising edge
- every 4th rising edge
- every 16th rising edge

The event is selected by control bits, CCP1M3:CCP1M0 (CCP1CON<3:0>). When a capture is made, the interrupt request flag bit, CCP1IF (PIR1<2>), is set; it must be cleared in software. If another capture occurs before the value in register CCP1 is read, the old captured value is overwritten by the new captured value.

16.2.1 CCP PIN CONFIGURATION

In Capture mode, the RC2/CCP1 pin should be configured as an input by setting the TRISC<2> bit.

Note: If the RC2/CCP1 is configured as an output, a write to the port can cause a capture condition.

16.2.2 TIMER1/TIMER3 MODE SELECTION

The timers that are to be used with the capture feature (Timer1 and/or Timer3) must be running in Timer mode, or Synchronized Counter mode. In Asynchronous Counter mode, the capture operation may not work. The timer to be used with each CCP module is selected in the T3CON register (see **Section 16.1.1 “CCP Modules and Timer Resources”**).

16.2.3 SOFTWARE INTERRUPT

When the Capture mode is changed, a false capture interrupt may be generated. The user should keep bit CCP1IE (PIE1<2>) clear to avoid false interrupts and should clear the flag bit, CCP1IF, following any such change in operating mode.

16.2.4 CCP PRESCALER

There are four prescaler settings, specified by bits CCP1M3:CCP1M0. Whenever the CCP module is turned off or the CCP module is not in Capture mode, the prescaler counter is cleared. This means that any Reset will clear the prescaler counter.

Switching from one capture prescaler to another may generate an interrupt. Also, the prescaler counter will not be cleared, therefore, the first capture may be from a non-zero prescaler. Example 16-1 shows the recommended method for switching between capture prescalers. This example also clears the prescaler counter and will not generate the “false” interrupt.

EXAMPLE 16-1: CHANGING BETWEEN CAPTURE PRESCALERS

```
CLRF  CCP1CON, F ; Turn CCP module off
MOVLW NEW_CAPT_PS ; Load WREG with the
                    ; new prescaler mode
                    ; value and CCP ON
MOVWF  CCP1CON   ; Load CCP1CON with
                    ; this value
```

FIGURE 16-2: CAPTURE MODE OPERATION BLOCK DIAGRAM

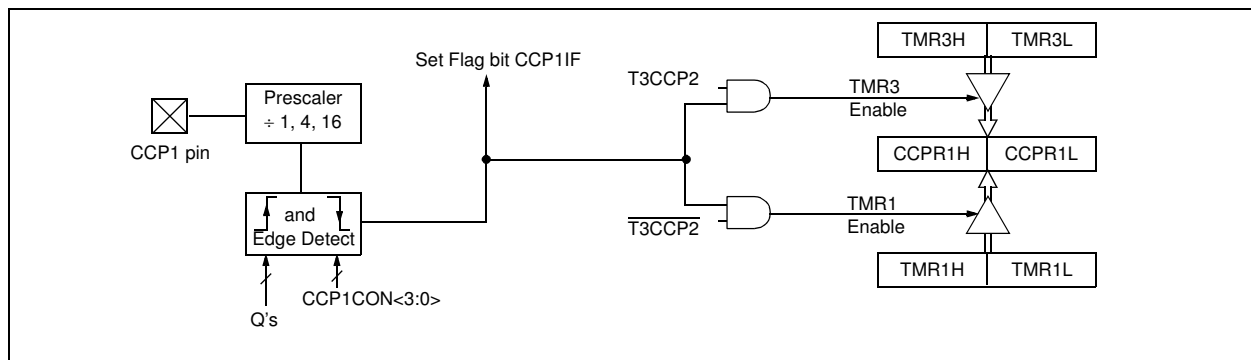

PIC18F6520/8520/6620/8620/6720/8720

16.3 Compare Mode

In Compare mode, the 16-bit CCPR1 register value is constantly compared against either the TMR1 register pair value or the TMR3 register pair value. When a match occurs, the CCP1 pin:

- is driven High
- is driven Low
- toggles output (high-to-low or low-to-high)
- remains unchanged

The action on the pin is based on the value of control bits, CCP1M3:CCP1M0. At the same time, interrupt flag bit CCP1IF (CCP2IF) is set.

16.3.1 CCP PIN CONFIGURATION

The user must configure the CCPx pin as an output by clearing the appropriate TRIS bit.

Note: Clearing the CCP1CON register will force the RC2/CCP1 compare output latch to the default low level. This is not the PORTC I/O data latch.

16.3.2 TIMER1/TIMER3 MODE SELECTION

Timer1 and/or Timer3 must be running in Timer mode, or Synchronized Counter mode, if the CCP module is using the compare feature. In Asynchronous Counter mode, the compare operation may not work.

16.3.3 SOFTWARE INTERRUPT MODE

When generate software interrupt is chosen, the CCP1 pin is not affected. Only a CCP interrupt is generated (if enabled).

16.3.4 SPECIAL EVENT TRIGGER

In this mode, an internal hardware trigger is generated, which may be used to initiate an action.

The special event trigger output of either CCP1 or CCP2, resets the TMR1 or TMR3 register pair, depending on which timer resource is currently selected. This allows the CCPR1 register to effectively be a 16-bit programmable period register for Timer1 or Timer3.

The CCP2 Special Event Trigger will also start an A/D conversion if the A/D module is enabled.

Note: The special event trigger from the CCP2 module will not set the Timer1 or Timer3 interrupt flag bits.

FIGURE 16-3: COMPARE MODE OPERATION BLOCK DIAGRAM

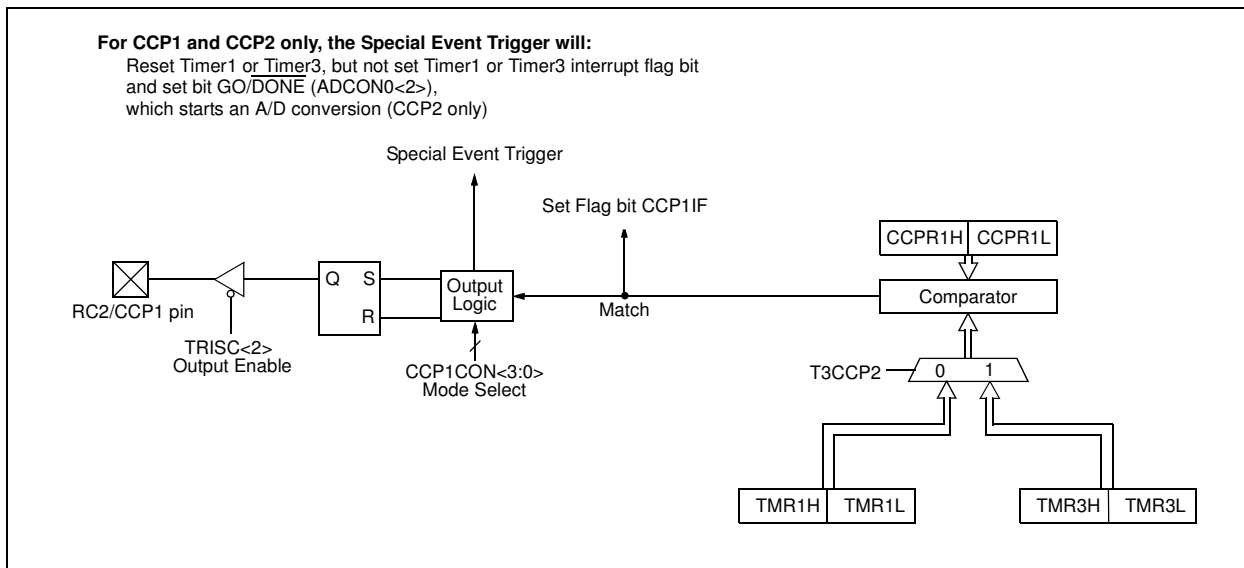

PIC18F6520/8520/6620/8620/6720/8720

TABLE 16-2: REGISTERS ASSOCIATED WITH CAPTURE, COMPARE, TIMER1 AND TIMER3

Name	Bit 7	Bit 6	Bit 5	Bit 4	Bit 3	Bit 2	Bit 1	Bit 0	Value on POR, BOR	Value on all other Resets
INTCON	GIE/GIEH	PEIE/GIEL	TMR0IE	INT0IE	RBIE	TMR0IF	INT0IF	RBIF	0000 0000	0000 0000
RCON	IPEN	—	—	\overline{RI}	\overline{TO}	\overline{PD}	\overline{POR}	\overline{BOR}	0--1 11qq	0--q qquu
PIR1	PSPIF	ADIF	RCIF	TXIF	SSPIF	CCP1IF	TMR2IF	TMR1IF	0000 0000	0000 0000
PIE1	PSPIE	ADIE	RCIE	TXIE	SSPIE	CCP1IE	TMR2IE	TMR1IE	0000 0000	0000 0000
IPR1	PSPIP	ADIP	RCIP	TXIP	SSPIP	CCP1IP	TMR2IP	TMR1IP	0111 1111	0111 1111
PIR2	—	CMIE	—	EEIE	BCLIF	LVDIF	TMR3IF	CCP2IF	-0-0 0000	---0 0000
PIE2	—	CMIE	—	EEIF	BCLIE	LVDIE	TMR3IE	CCP2IE	-0-0 0000	---0 0000
IPR2	—	CMIP	—	EEIP	BCLIP	LVDIP	TMR3IP	CCP2IP	-1-1 1111	---1 1111
PIR3	—	—	RC2IF	TX2IF	TMR4IF	CCP5IF	CCP4IF	CCP3IF	--00 0000	--00 0000
PIE3	—	—	RC2IE	TX2IE	TMR4IE	CCP5IE	CCP4IE	CCP3IE	--00 0000	--00 0000
IPR3	—	—	RC2IP	TX2IP	TMR4IP	CCP5IP	CCP4IP	CCP3IP	--11 1111	--11 1111
TRISC	PORTC Data Direction Register								1111 1111	1111 1111
TMR1L	Holding Register for the Least Significant Byte of the 16-bit TMR1 Register								xxxx xxxx	uuuu uuuu
TMR1H	Holding Register for the Most Significant Byte of the 16-bit TMR1 Register								xxxx xxxx	uuuu uuuu
T1CON	RD16	—	T1CKPS1	T1CKPS0	T1OSCEN	$\overline{T1SYNC}$	TMR1CS	TMR1ON	0-00 0000	u-uu uuuu
TMR3H	Timer3 Register High Byte								xxxx xxxx	uuuu uuuu
TMR3L	Timer3 Register Low Byte								xxxx xxxx	uuuu uuuu
T3CON	RD16	T3CCP2	T3CKPS1	T3CKPS0	T3CCP1	$\overline{T3SYNC}$	TMR3CS	TMR3ON	0000 0000	uuuu uuuu
CCPRxL ⁽¹⁾	Capture/Compare/PWM Register x (LSB)								xxxx xxxx	uuuu uuuu
CCPRxH ⁽¹⁾	Capture/Compare/PWM Register x (MSB)								xxxx xxxx	uuuu uuuu
CCPxCON ⁽¹⁾	—	—	DCxB1	DCxB0	CCPxM3	CCPxM2	CCPxM1	CCPxM0	--00 0000	--00 0000

Legend: x = unknown, u = unchanged, - = unimplemented, read as '0'.
Shaded cells are not used by Capture and Compare, Timer1 or Timer3.

Note 1: Generic term for all of the identical registers of this name for all CCP modules, where 'x' identifies the individual module (CCP1 through CCP5). Bit assignments and Reset values for all registers of the same generic name are identical.

PIC18F6520/8520/6620/8620/6720/8720

16.4 PWM Mode

In Pulse Width Modulation (PWM) mode, the CCP1 pin produces up to a 10-bit resolution PWM output. Since the CCP1 pin is multiplexed with the PORTC data latch, the TRISC<2> bit must be cleared to make the CCP1 pin an output.

Note: Clearing the CCP1CON register will force the CCP1 PWM output latch to the default low level. This is not the PORTC I/O data latch.

Figure 16-4 shows a simplified block diagram of the CCP module in PWM mode.

For a step-by-step procedure on how to set up the CCP module for PWM operation, see **Section 16.4.3 “Setup for PWM Operation”**.

FIGURE 16-4: SIMPLIFIED PWM BLOCK DIAGRAM

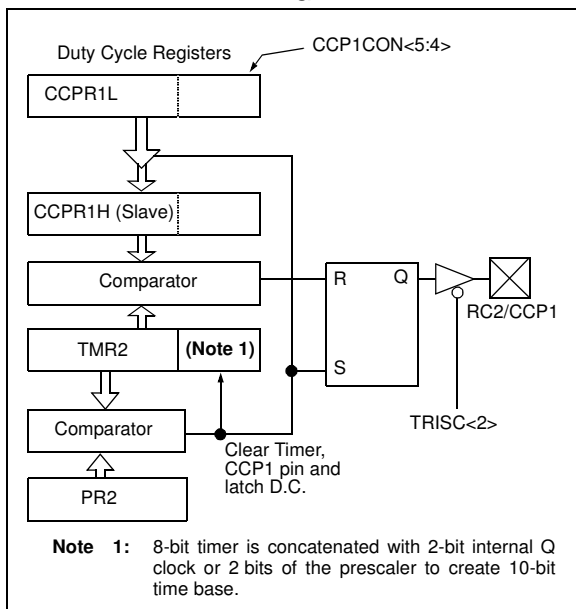

A PWM output (Figure 16-5) has a time base (period) and a time that the output stays high (duty cycle). The frequency of the PWM is the inverse of the period (1/period).

FIGURE 16-5: PWM OUTPUT

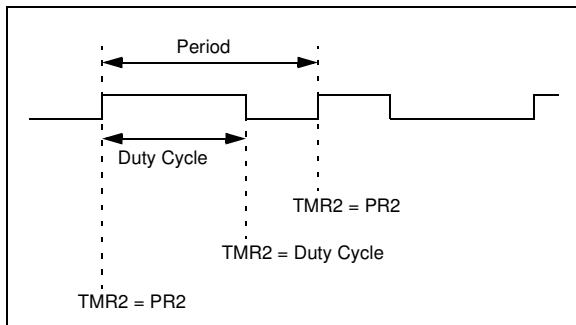

16.4.1 PWM PERIOD

The PWM period is specified by writing to the PR2 register. The PWM period can be calculated using the following formula:

EQUATION 16-1:

$$\text{PWM Period} = (\text{PR2} + 1) \cdot 4 \cdot \text{Tosc} \cdot (\text{TMR2 Prescale Value})$$

PWM frequency is defined as $1/[\text{PWM period}]$.

When TMR2 is equal to PR2, the following three events occur on the next increment cycle:

- TMR2 is cleared
- The CCP1 pin is set (exception: if PWM duty cycle = 0%, the CCP1 pin will not be set)
- The PWM duty cycle is latched from CCPR1L into CCPR1H

Note: The Timer2 and Timer4 postscalers (see **Section 13.0 “Timer2 Module”**) are not used in the determination of the PWM frequency. The postscaler could be used to have a servo update rate at a different frequency than the PWM output.

16.4.2 PWM DUTY CYCLE

The PWM duty cycle is specified by writing to the CCPR1L register and to the CCP1CON<5:4> bits. Up to 10-bit resolution is available. The CCPR1L contains the eight MSBs and the CCP1CON<5:4> contains the two LSBs. This 10-bit value is represented by CCPR1L:CCP1CON<5:4>. The following equation is used to calculate the PWM duty cycle in time:

EQUATION 16-2:

$$\text{PWM Duty Cycle} = (\text{CCPR1L:CCP1CON<5:4>}) \cdot \text{Tosc} \cdot (\text{TMR2 Prescale Value})$$

CCPR1L and CCP1CON<5:4> can be written to at any time, but the duty cycle value is not latched into CCPR1H until after a match between PR2 and TMR2 occurs (i.e., the period is complete). In PWM mode, CCPR1H is a read-only register.

The CCPR1H register and a 2-bit internal latch are used to double-buffer the PWM duty cycle. This doublebuffering is essential for glitchless PWM operation.

When the CCPR1H and 2-bit latch match TMR2, concatenated with an internal 2-bit Q clock or 2 bits of the TMR2 prescaler, the CCP1 pin is cleared.

PIC18F6520/8520/6620/8620/6720/8720

The maximum PWM resolution (bits) for a given PWM frequency is given by the equation:

EQUATION 16-3:

$$\text{PWM Resolution (max)} = \frac{\log\left(\frac{F_{\text{OSC}}}{F_{\text{PWM}}}\right)}{\log(2)} \text{ bits}$$

Note: If the PWM duty cycle value is longer than the PWM period, the CCP1 pin will not be cleared.

16.4.3 SETUP FOR PWM OPERATION

The following steps should be taken when configuring the CCP module for PWM operation:

1. Set the PWM period by writing to the PR2 register.
2. Set the PWM duty cycle by writing to the CCPR1L register and CCP1CON<5:4> bits.
3. Make the CCP1 pin an output by clearing the TRISC<2> bit.
4. Set the TMR2 prescale value and enable Timer2 by writing to T2CON.
5. Configure the CCP1 module for PWM operation.

TABLE 16-3: EXAMPLE PWM FREQUENCIES AND RESOLUTIONS AT 40 MHz

PWM Frequency	2.44 kHz	9.77 kHz	39.06 kHz	156.25 kHz	312.50 kHz	416.67 kHz
Timer Prescaler (1, 4, 16)	16	4	1	1	1	1
PR2 Value	FFh	FFh	FFh	3Fh	1Fh	17h
Maximum Resolution (bits)	14 → 10	12 → 10	10	8	7	6.58

TABLE 16-4: REGISTERS ASSOCIATED WITH PWM, TIMER2 AND TIMER4

Name	Bit 7	Bit 6	Bit 5	Bit 4	Bit 3	Bit 2	Bit 1	Bit 0	Value on POR, BOR	Value on all other Resets
INTCON	GIE/GIEH	PEIE/GIEL	TMR0IE	INT0IE	RBIE	TMR0IF	INT0IF	RBFIF	0000 0000	0000 0000
RCON	IPEN	—	—	RI	TO	PD	POR	BOR	0--1 11qq	0--q qquu
PIR1	PSPIF	ADIF	RCIF	TXIF	SSPIF	CCP1IF	TMR2IF	TMR1IF	0000 0000	0000 0000
PIE1	PSPIE	ADIE	RCIE	TXIE	SSPIE	CCP1IE	TMR2IE	TMR1IE	0000 0000	0000 0000
IPR1	PSPIP	ADIP	RCIP	TXIP	SSPIP	CCP1IP	TMR2IP	TMR1IP	0111 1111	0111 1111
PIR2	—	CMIE	—	EEIE	BCLIF	LVDIF	TMR3IF	CCP2IF	-0-0 0000	---0 0000
PIE2	—	CMIF	—	EEIF	BCLIE	LVDIE	TMR3IE	CCP2IE	-0-0 0000	---0 0000
IPR2	—	CMIP	—	EEIP	BCLIP	LVDIP	TMR3IP	CCP2IP	-1-1 1111	---1 1111
PIR3	—	—	RC2IF	TX2IF	TMR4IF	CCP5IF	CCP4IF	CCP3IF	--00 0000	--00 0000
PIE3	—	—	RC2IE	TX2IE	TMR4IE	CCP5IE	CCP4IE	CCP3IE	--00 0000	--00 0000
IPR3	—	—	RC2IP	TX2IP	TMR4IP	CCP5IP	CCP4IP	CCP3IP	--11 1111	--11 1111
TMR2	Timer2 Module Register								0000 0000	0000 0000
PR2	Timer2 Module Period Register								1111 1111	1111 1111
T2CON	—	T2OUTPS3	T2OUTPS2	T2OUTPS1	T2OUTPS0	TMR2ON	T2CKPS1	T2CKPS0	-000 0000	-000 0000
T3CON	RD16	T3CCP2	T3CKPS1	T3CKPS0	T3CCP1	T3SYNC	TMR3CS	TMR3ON	0000 0000	uuuu uuuu
TMR4	Timer4 Register								0000 0000	uuuu uuuu
PR4	Timer4 Period Register								1111 1111	uuuu uuuu
T4CON	—	T4OUTPS3	T4OUTPS2	T4OUTPS1	T4OUTPS0	TMR4ON	T4CKPS1	T4CKPS0	-000 0000	uuuu uuuu
CCPRxL ⁽¹⁾	Capture/Compare/PWM Register x (LSB)								xxxx xxxx	uuuu uuuu
CCPRxH ⁽¹⁾	Capture/Compare/PWM Register x (MSB)								xxxx xxxx	uuuu uuuu
CCPxCON ⁽¹⁾	—	—	DCxB1	DCxB0	CCPxM3	CCPxM2	CCPxM1	CCPxM0	--00 0000	--00 0000

Legend: x = unknown, u = unchanged, — = unimplemented, read as '0'. Shaded cells are not used by PWM, Timer2, or Timer4.

Note 1: Generic term for all of the identical registers of this name for all CCP modules, where 'x' identifies the individual module (CCP1 through CCP5). Bit assignments and Reset values for all registers of the same generic name are identical.

PIC18F6520/8520/6620/8620/6720/8720

NOTES:

PIC18F6520/8520/6620/8620/6720/8720

17.0 MASTER SYNCHRONOUS SERIAL PORT (MSSP) MODULE

17.1 Master SSP (MSSP) Module Overview

The Master Synchronous Serial Port (MSSP) module is a serial interface, useful for communicating with other peripheral or microcontroller devices. These peripheral devices may be serial EEPROMs, shift registers, display drivers, A/D converters, etc. The MSSP module can operate in one of two modes:

- Serial Peripheral Interface (SPI)
- Inter-Integrated Circuit (I²C)
 - Full Master mode
 - Slave mode (with general address call)

The I²C interface supports the following modes in hardware:

- Master mode
- Multi-Master mode
- Slave mode

17.2 Control Registers

The MSSP module has three associated registers. These include a status register (SSPSTAT) and two control registers (SSPCON1 and SSPCON2). The use of these registers and their individual configuration bits differ significantly, depending on whether the MSSP module is operated in SPI or I²C mode.

Additional details are provided under the individual sections.

17.3 SPI Mode

The SPI mode allows 8 bits of data to be synchronously transmitted and received simultaneously. All four modes of SPI are supported. To accomplish communication, typically three pins are used:

- Serial Data Out (SDO) – RC5/SDO
- Serial Data In (SDI) – RC4/SDI/SDA
- Serial Clock (SCK) – RC3/SCK/SCL

Additionally, a fourth pin may be used when in a Slave mode of operation:

- Slave Select (\overline{SS}) – RF7/ \overline{SS}

Figure 17-1 shows the block diagram of the MSSP module when operating in SPI mode.

FIGURE 17-1: MSSP BLOCK DIAGRAM (SPI MODE)

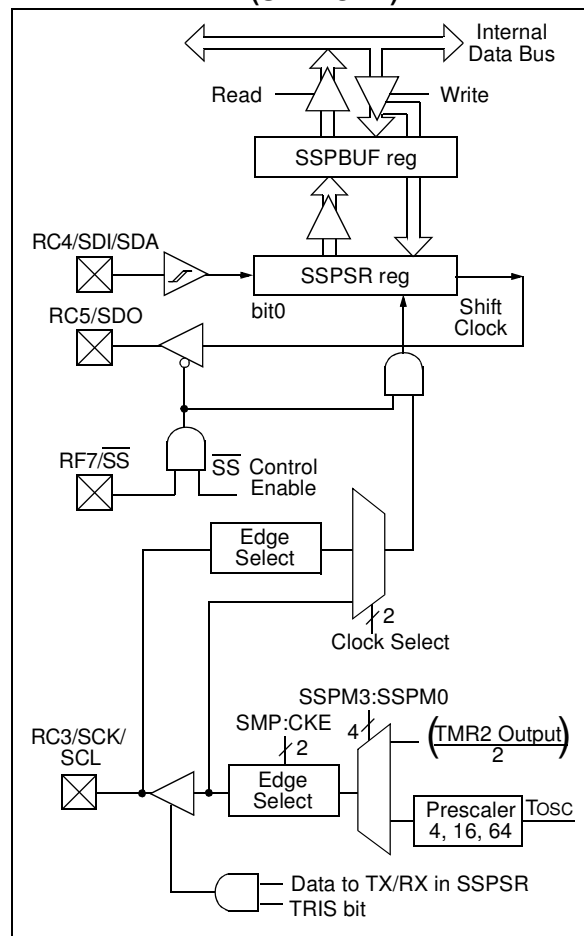

PIC18F6520/8520/6620/8620/6720/8720

17.3.1 REGISTERS

The MSSP module has four registers for SPI mode operation. These are:

- MSSP Control Register 1 (SSPCON1)
- MSSP Status Register (SSPSTAT)
- Serial Receive/Transmit Buffer (SSPBUF)
- MSSP Shift Register (SSPSR) – Not directly accessible

SSPCON1 and SSPSTAT are the control and status registers in SPI mode operation. The SSPCON1 register is readable and writable. The lower 6 bits of the SSPSTAT are read-only. The upper two bits of the SSPSTAT are read/write.

SSPSR is the shift register used for shifting data in or out. SSPBUF is the buffer register to which data bytes are written to or read from.

In receive operations, SSPSR and SSPBUF together create a double-buffered receiver. When SSPSR receives a complete byte, it is transferred to SSPBUF and the SSPIF interrupt is set.

During transmission, the SSPBUF is not double-buffered. A write to SSPBUF will write to both SSPBUF and SSPSR.

REGISTER 17-1: SSPSTAT: MSSP STATUS REGISTER (SPI MODE)

R/W-0	R/W-0	R-0	R-0	R-0	R-0	R-0	R-0
SMP	CKE	D/A	P	S	R/W	UA	BF
bit 7							bit 0

- bit 7 **SMP:** Sample bit
SPI Master mode:
 1 = Input data sampled at end of data output time
 0 = Input data sampled at middle of data output time
SPI Slave mode:
 SMP must be cleared when SPI is used in Slave mode.
- bit 6 **CKE:** SPI Clock Select bit
 1 = Transmit occurs on transition from active to Idle clock state
 0 = Transmit occurs on transition from Idle to active clock state
Note: Polarity of clock state is set by the CKP bit (SSPCON1<4>).
- bit 5 **D/A:** Data/Address bit
 Used in I²C mode only.
- bit 4 **P:** Stop bit
 Used in I²C mode only. This bit is cleared when the MSSP module is disabled, SSPEN is cleared.
- bit 3 **S:** Start bit
 Used in I²C mode only.
- bit 2 **R/W:** Read/Write bit information
 Used in I²C mode only.
- bit 1 **UA:** Update Address bit
 Used in I²C mode only.
- bit 0 **BF:** Buffer Full Status bit (Receive mode only)
 1 = Receive complete, SSPBUF is full
 0 = Receive not complete, SSPBUF is empty

Legend:

R = Readable bit	W = Writable bit	U = Unimplemented bit, read as '0'
- n = Value at POR	'1' = Bit is set	'0' = Bit is cleared x = Bit is unknown

PIC18F6520/8520/6620/8620/6720/8720

REGISTER 17-2: SSPCON1: MSSP CONTROL REGISTER1 (SPI MODE)

R/W-0	R/W-0	R/W-0	R/W-0	R/W-0	R/W-0	R/W-0	R/W-0
WCOL	SSPOV	SSPEN	CKP	SSPM3	SSPM2	SSPM1	SSPM0
bit 7							bit 0

bit 7 **WCOL:** Write Collision Detect bit (Transmit mode only)

- 1 = The SSPBUF register is written while it is still transmitting the previous word (must be cleared in software)
- 0 = No collision

bit 6 **SSPOV:** Receive Overflow Indicator bit

SPI Slave mode:

- 1 = A new byte is received while the SSPBUF register is still holding the previous data. In case of overflow, the data in SSPSR is lost. Overflow can only occur in Slave mode. The user must read the SSPBUF, even if only transmitting data, to avoid setting overflow (must be cleared in software).
- 0 = No overflow

Note: In Master mode, the overflow bit is not set, since each new reception (and transmission) is initiated by writing to the SSPBUF register.

bit 5 **SSPEN:** Synchronous Serial Port Enable bit

- 1 = Enables serial port and configures SCK, SDO, SDI and \overline{SS} as serial port pins
- 0 = Disables serial port and configures these pins as I/O port pins

Note: When enabled, these pins must be properly configured as input or output.

bit 4 **CKP:** Clock Polarity Select bit

- 1 = Idle state for clock is a high level
- 0 = Idle state for clock is a low level

bit 3-0 **SSPM3:SSPM0:** Synchronous Serial Port Mode Select bits

- 0101 = SPI Slave mode, clock = SCK pin, \overline{SS} pin control disabled, \overline{SS} can be used as I/O pin
- 0100 = SPI Slave mode, clock = SCK pin, \overline{SS} pin control enabled
- 0011 = SPI Master mode, clock = TMR2 output/2
- 0010 = SPI Master mode, clock = Fosc/64
- 0001 = SPI Master mode, clock = Fosc/16
- 0000 = SPI Master mode, clock = Fosc/4

Note: Bit combinations not specifically listed here are either reserved, or implemented in I²C mode only.

Legend:

R = Readable bit	W = Writable bit	U = Unimplemented bit, read as '0'
- n = Value at POR	'1' = Bit is set	'0' = Bit is cleared x = Bit is unknown

PIC18F6520/8520/6620/8620/6720/8720

17.3.2 OPERATION

When initializing the SPI, several options need to be specified. This is done by programming the appropriate control bits (SSPCON1<5:0> and SSPSTAT<7:6>). These control bits allow the following to be specified:

- Master mode (SCK is the clock output)
- Slave mode (SCK is the clock input)
- Clock Polarity (Idle state of SCK)
- Data input sample phase (middle or end of data output time)
- Clock edge (output data on rising/falling edge of SCK)
- Clock Rate (Master mode only)
- Slave Select mode (Slave mode only)

The MSSP consists of a Transmit/Receive Shift Register (SSPSR) and a Buffer register (SSPBUF). The SSPSR shifts the data in and out of the device, MSb first. The SSPBUF holds the data that was written to the SSPSR until the received data is ready. Once the 8 bits of data have been received, that byte is moved to the SSPBUF register. Then, the Buffer Full detect bit, BF (SSPSTAT<0>) and the interrupt flag bit, SSPIF, are set. This double-buffering of the received data (SSPBUF) allows the next byte to start reception before

reading the data that was just received. Any write to the SSPBUF register during transmission/reception of data will be ignored and the Write Collision detect bit, WCOL (SSPCON1<7>), will be set. User software must clear the WCOL bit so that it can be determined if the following write(s) to the SSPBUF register completed successfully.

When the application software is expecting to receive valid data, the SSPBUF should be read before the next byte of data to transfer is written to the SSPBUF. Buffer Full bit, BF (SSPSTAT<0>), indicates when SSPBUF has been loaded with the received data (transmission is complete). When the SSPBUF is read, the BF bit is cleared. This data may be irrelevant if the SPI is only a transmitter. Generally, the MSSP interrupt is used to determine when the transmission/reception has completed. The SSPBUF must be read and/or written. If the interrupt method is not going to be used, then software polling can be done to ensure that a write collision does not occur. Example 17-1 shows the loading of the SSPBUF (SSPSR) for data transmission.

The SSPSR is not directly readable or writable and can only be accessed by addressing the SSPBUF register. Additionally, the MSSP Status register (SSPSTAT) indicates the various status conditions.

EQUATION 17-1: LOADING THE SSPBUF (SSPSR) REGISTER

```
LOOP BTFSS SSPSTAT, BF ;Has data been received (transmit complete)?
    BRA LOOP ;No
    MOVF SSPBUF, W ;WREG reg = contents of SSPBUF
    MOVWF RXDATA ;Save in user RAM, if data is meaningful
    MOVF TXDATA, W ;W reg = contents of TXDATA
    MOVWF SSPBUF ;New data to transmit
```

PIC18F6520/8520/6620/8620/6720/8720

17.3.3 ENABLING SPI I/O

To enable the serial port, SSP Enable bit, SSPEN (SSPCON1<5>), must be set. To reset or reconfigure SPI mode, clear the SSPEN bit, reinitialize the SSPCON registers and then set the SSPEN bit. This configures the SDI, SDO, SCK and \overline{SS} pins as serial port pins. For the pins to behave as the serial port function, some must have their data direction bits (in the TRIS register) appropriately programmed as follows:

- SDI is automatically controlled by the SPI module
- SDO must have TRISC<5> bit cleared
- SCK (Master mode) must have TRISC<3> bit cleared
- SCK (Slave mode) must have TRISC<3> bit set
- \overline{SS} must have TRISF<7> bit set

Any serial port function that is not desired may be overridden by programming the corresponding data direction (TRIS) register to the opposite value.

17.3.4 TYPICAL CONNECTION

Figure 17-2 shows a typical connection between two microcontrollers. The master controller (Processor 1) initiates the data transfer by sending the SCK signal. Data is shifted out of both shift registers on their programmed clock edge and latched on the opposite edge of the clock. Both processors should be programmed to the same Clock Polarity (CKP), then both controllers would send and receive data at the same time. Whether the data is meaningful (or dummy data) depends on the application software. This leads to three scenarios for data transmission:

- Master sends data – Slave sends dummy data
- Master sends data – Slave sends data
- Master sends dummy data – Slave sends data

FIGURE 17-2: SPI MASTER/SLAVE CONNECTION

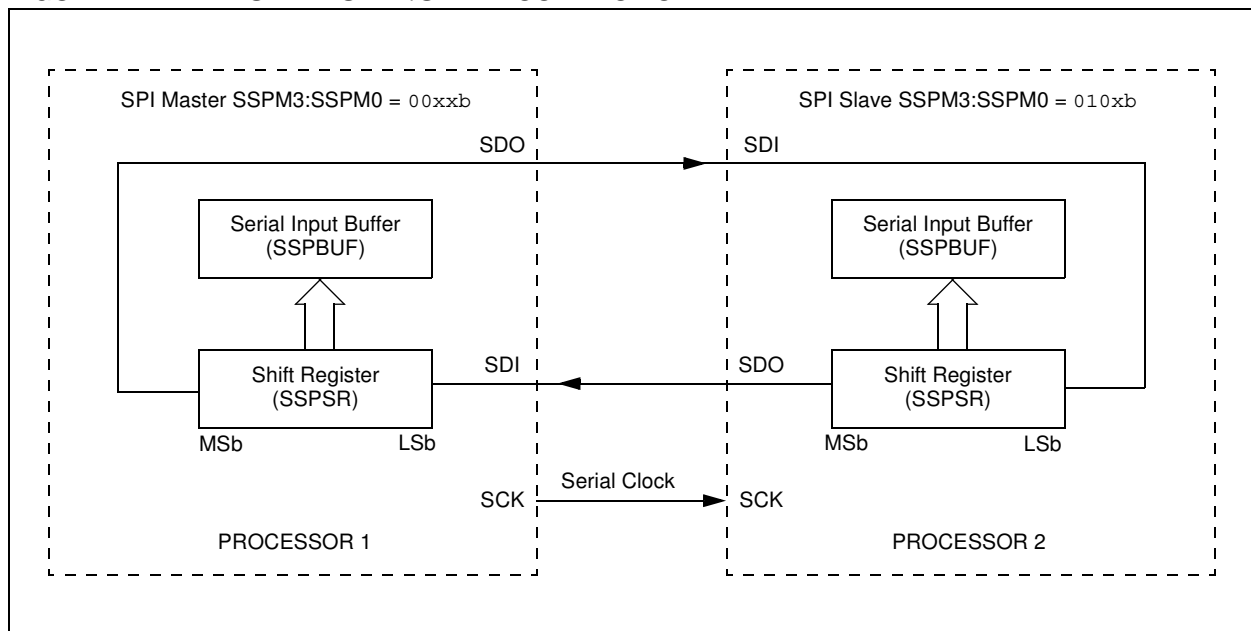

PIC18F6520/8520/6620/8620/6720/8720

17.3.5 MASTER MODE

The master can initiate the data transfer at any time because it controls the SCK. The master determines when the slave (Processor 2, Figure 17-2) is to broadcast data by the software protocol.

In Master mode, the data is transmitted/received as soon as the SSPBUF register is written to. If the SPI is only going to receive, the SDO output could be disabled (programmed as an input). The SSPSR register will continue to shift in the signal present on the SDI pin at the programmed clock rate. As each byte is received, it will be loaded into the SSPBUF register as if a normal received byte (interrupts and status bits appropriately set). This could be useful in receiver applications as a "Line Activity Monitor" mode.

The clock polarity is selected by appropriately programming the CKP bit (SSPCON1<4>). This then, would give waveforms for SPI communication, as shown in

Figure 17-3, Figure 17-5 and Figure 17-6, where the MSB is transmitted first. In Master mode, the SPI clock rate (bit rate) is user-programmable to be one of the following:

- $F_{OSC}/4$ (or T_{CY})
- $F_{OSC}/16$ (or $4 \cdot T_{CY}$)
- $F_{OSC}/64$ (or $16 \cdot T_{CY}$)
- $Timer2\ output/2$

This allows a maximum data rate (at 40 MHz) of 10.00 Mbps.

Figure 17-3 shows the waveforms for Master mode. When the CKE bit is set, the SDO data is valid before there is a clock edge on SCK. The change of the input sample is shown based on the state of the SMP bit. The time when the SSPBUF is loaded with the received data is shown.

FIGURE 17-3: SPI MODE WAVEFORM (MASTER MODE)

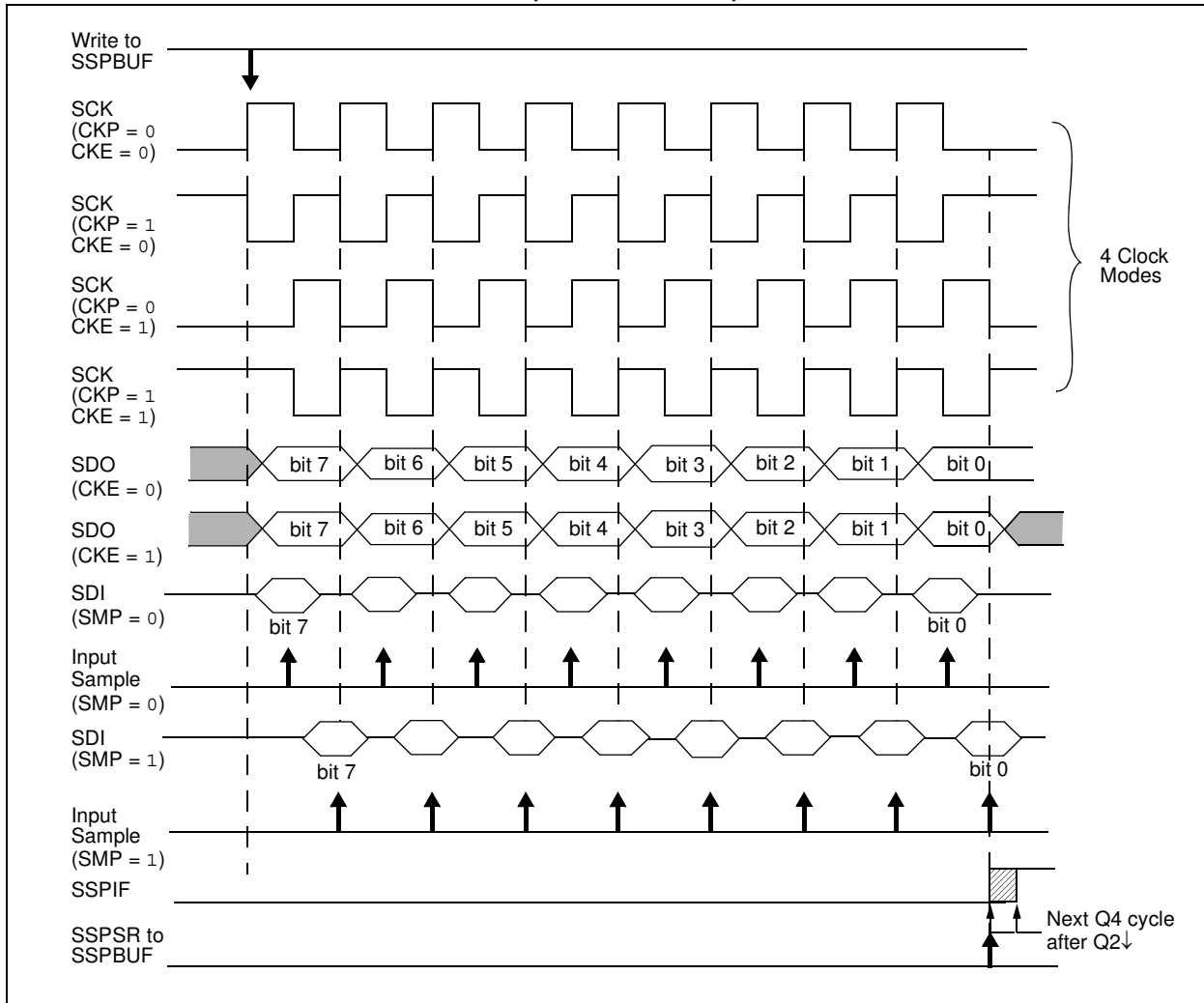

PIC18F6520/8520/6620/8620/6720/8720

17.3.6 SLAVE MODE

In Slave mode, the data is transmitted and received as the external clock pulses appear on SCK. When the last bit is latched, the SSPIF interrupt flag bit is set.

While in Slave mode, the external clock is supplied by the external clock source on the SCK pin. This external clock must meet the minimum high and low times as specified in the electrical specifications.

While in Sleep mode, the slave can transmit/receive data. When a byte is received, the device will wake-up from Sleep.

17.3.7 SLAVE SELECT SYNCHRONIZATION

The \overline{SS} pin allows a Synchronous Slave mode. The SPI must be in Slave mode with \overline{SS} pin control enabled ($SSPCON1\langle 3:0 \rangle = 04h$). The pin must not be driven low for the \overline{SS} pin to function as an input. The Data Latch must be high. When the \overline{SS} pin is low, transmission and reception are enabled and the SDO pin is driven. When the \overline{SS} pin goes high, the SDO pin is no

longer driven, even if in the middle of a transmitted byte and becomes a floating output. External pull-up/pull-down resistors may be desirable, depending on the application.

- Note 1:** When the SPI is in Slave mode with \overline{SS} pin control enabled ($SSPCON\langle 3:0 \rangle = 0100$), the SPI module will reset if the \overline{SS} pin is set to VDD.
- 2:** If the SPI is used in Slave mode with CKE set, then the \overline{SS} pin control must be enabled.

When the SPI module resets, the bit counter is forced to '0'. This can be done by either forcing the \overline{SS} pin to a high level or clearing the SSPEN bit.

To emulate two-wire communication, the SDO pin can be connected to the SDI pin. When the SPI needs to operate as a receiver, the SDO pin can be configured as an input. This disables transmissions from the SDO. The SDI can always be left as an input (SDI function), since it cannot create a bus conflict.

FIGURE 17-4: SLAVE SYNCHRONIZATION WAVEFORM

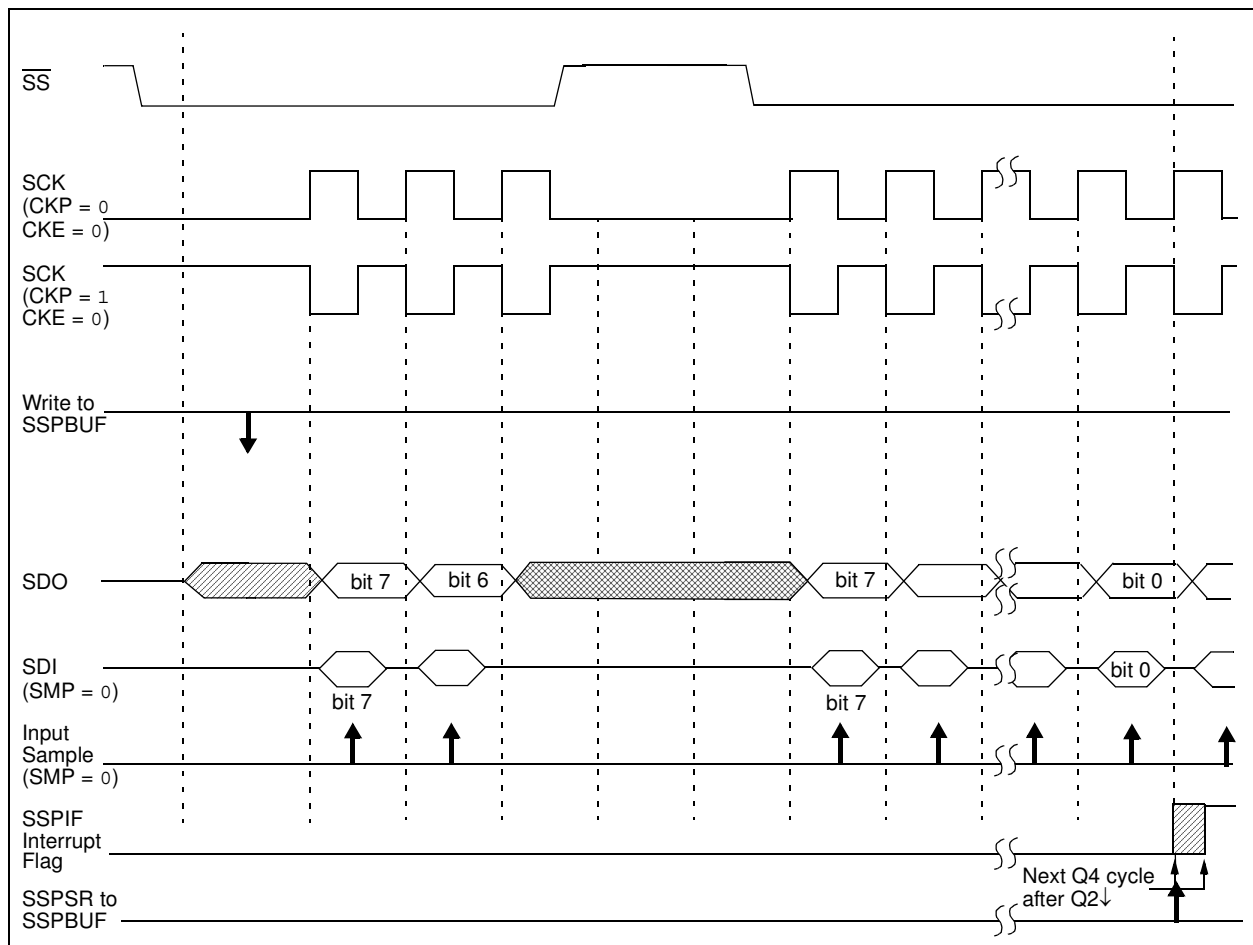

PIC18F6520/8520/6620/8620/6720/8720

FIGURE 17-5: SPI MODE WAVEFORM (SLAVE MODE WITH CKE = 0)

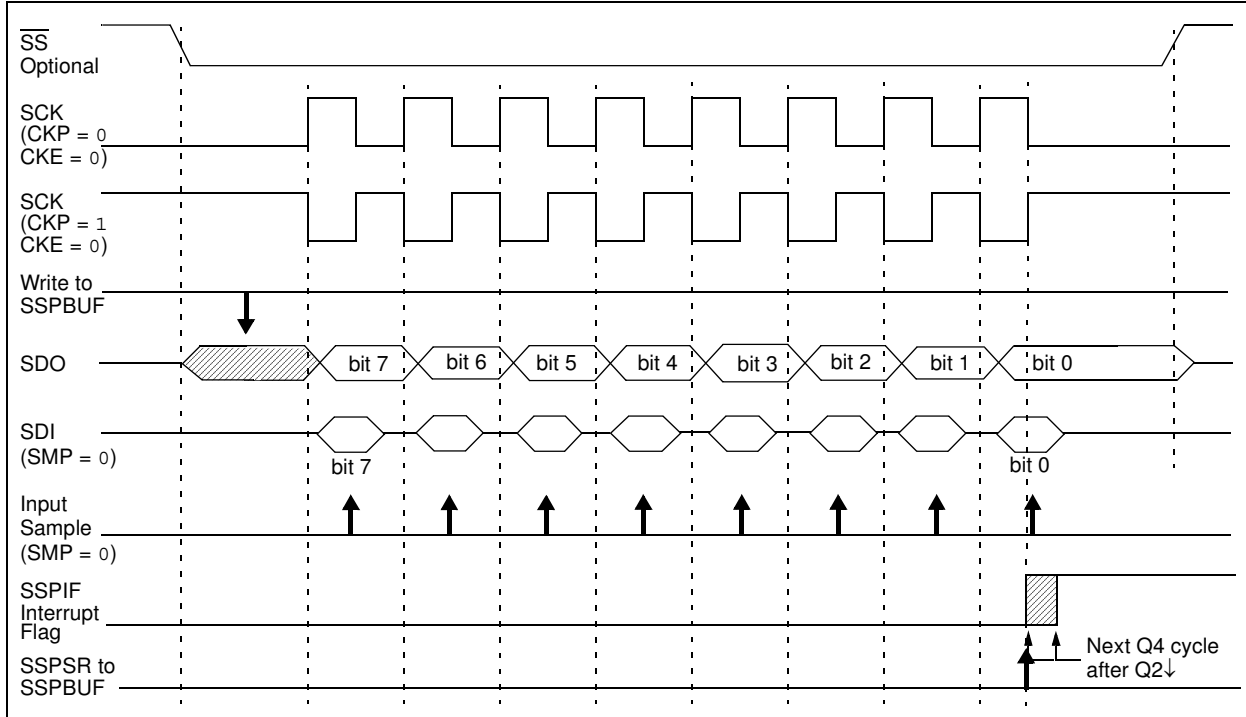
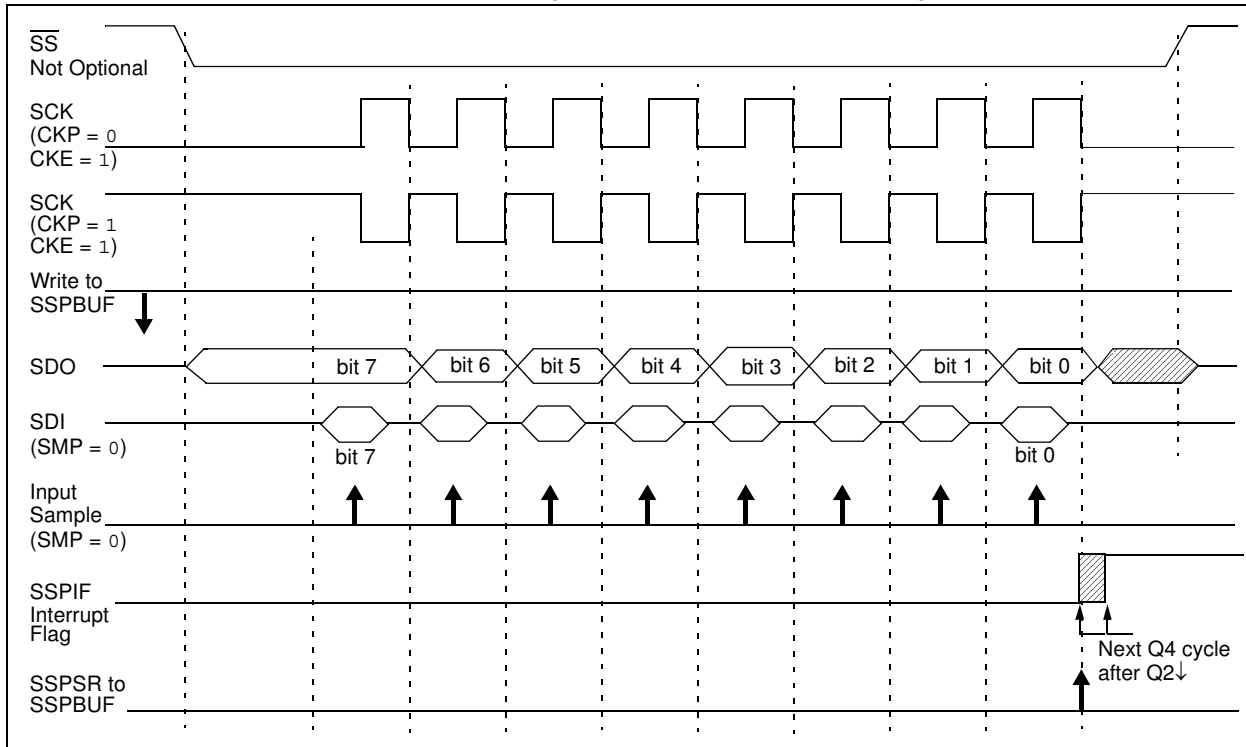

FIGURE 17-6: SPI MODE WAVEFORM (SLAVE MODE WITH CKE = 1)



PIC18F6520/8520/6620/8620/6720/8720

17.3.8 SLEEP OPERATION

In Master mode, all module clocks are halted and the transmission/reception will remain in that state until the device wakes from Sleep. After the device returns to normal mode, the module will continue to transmit/receive data.

In Slave mode, the SPI Transmit/Receive Shift register operates asynchronously to the device. This allows the device to be placed in Sleep mode and data to be shifted into the SPI Transmit/Receive Shift register. When all 8 bits have been received, the MSSP interrupt flag bit will be set and if enabled, will wake the device from Sleep.

17.3.9 EFFECTS OF A RESET

A Reset disables the MSSP module and terminates the current transfer.

17.3.10 BUS MODE COMPATIBILITY

Table 17-1 shows the compatibility between the standard SPI modes and the states of the CKP and CKE control bits.

TABLE 17-1: SPI BUS MODES

Standard SPI Mode Terminology	Control Bits State	
	CKP	CKE
0, 0	0	1
0, 1	0	0
1, 0	1	1
1, 1	1	0

There is also an SMP bit, which controls when the data is sampled.

TABLE 17-2: REGISTERS ASSOCIATED WITH SPI OPERATION

Name	Bit 7	Bit 6	Bit 5	Bit 4	Bit 3	Bit 2	Bit 1	Bit 0	Value on POR, BOR	Value on all other Resets
INTCON	GIE/GIEH	PEIE/GIEL	TMR0IE	INT0IE	RBIE	TMR0IF	INT0IF	RBIF	0000 0000	0000 0000
PIR1	PSPIF	ADIF	RCIF	TXIF	SSPIF	CCP1IF	TMR2IF	TMR1IF	0000 0000	0000 0000
PIE1	PSPIE	ADIE	RCIE	TXIE	SSPIE	CCP1IE	TMR2IE	TMR1IE	0000 0000	0000 0000
IPR1	PSPIP	ADIP	RCIP	TXIP	SSPIP	CCP1IP	TMR2IP	TMR1IP	0111 1111	0111 1111
TRISC	PORTC Data Direction Register								1111 1111	1111 1111
TRISF	TRISF7	TRISF6	TRISF5	TRISF4	TRISF3	TRISF2	TRISF1	TRISF0	1111 1111	uuuu uuuu
SSPBUF	Synchronous Serial Port Receive Buffer/Transmit Register								xxxx xxxx	uuuu uuuu
SSPCON	WCOL	SSPOV	SSPEN	CKP	SSPM3	SSPM2	SSPM1	SSPM0	0000 0000	0000 0000
SSPSTAT	SMP	CKE	D/ \bar{A}	P	S	R/ \bar{W}	UA	BF	0000 0000	0000 0000

Legend: x = unknown, u = unchanged, - = unimplemented, read as '0'. Shaded cells are not used by the MSSP in SPI mode.

PIC18F6520/8520/6620/8620/6720/8720

17.4 I²C Mode

The MSSP module in I²C mode fully implements all master and slave functions (including general call support) and provides interrupts on Start and Stop bits in hardware to determine a free bus (multi-master function). The MSSP module implements the standard mode specifications, as well as 7-bit and 10-bit addressing.

Two pins are used for data transfer:

- Serial clock (SCL) – RC3/SCK/SCL
- Serial data (SDA) – RC4/SDI/SDA

The user must configure these pins as inputs or outputs through the TRISC<4:3> bits.

FIGURE 17-7: MSSP BLOCK DIAGRAM (I²C MODE)

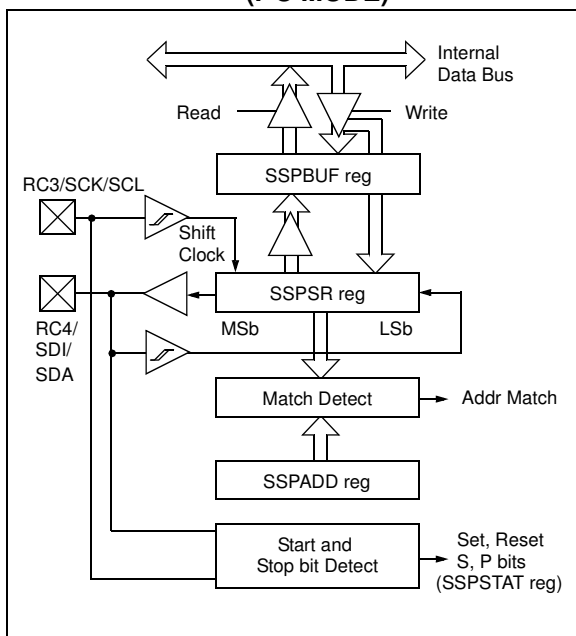

17.4.1 REGISTERS

The MSSP module has six registers for I²C operation. These are:

- MSSP Control Register 1 (SSPCON1)
- MSSP Control Register 2 (SSPCON2)
- MSSP Status Register (SSPSTAT)
- Serial Receive/Transmit Buffer (SSPBUF)
- MSSP Shift Register (SSPSR) – Not directly accessible
- MSSP Address Register (SSPADD)

SSPCON, SSPCON2 and SSPSTAT are the control and status registers in I²C mode operation. The SSPCON and SSPCON2 registers are readable and writable. The lower six bits of the SSPSTAT are read-only. The upper two bits of the SSPSTAT are read/write.

SSPSR is the shift register used for shifting data in or out. SSPBUF is the buffer register to which data bytes are written to or read from.

SSPADD register holds the slave device address when the SSP is configured in I²C Slave mode. When the SSP is configured in Master mode, the lower seven bits of SSPADD act as the Baud Rate Generator reload value.

In receive operations, SSPSR and SSPBUF together, create a double-buffered receiver. When SSPSR receives a complete byte, it is transferred to SSPBUF and the SSPIF interrupt is set.

During transmission, the SSPBUF is not double-buffered. A write to SSPBUF will write to both SSPBUF and SSPSR.

PIC18F6520/8520/6620/8620/6720/8720

REGISTER 17-3: SSPSTAT: MSSP STATUS REGISTER (I²C MODE)

R/W-0	R/W-0	R-0	R-0	R-0	R-0	R-0	R-0
SMP	CKE	D/A	P	S	R/W	UA	BF
bit 7						bit 0	

bit 7 **SMP:** Slew Rate Control bit

In Master or Slave mode:

1 = Slew rate control disabled for standard speed mode (100 kHz and 1 MHz)

0 = Slew rate control enabled for high-speed mode (400 kHz)

bit 6 **CKE:** SMBus Select bit

In Master or Slave mode:

1 = Enable SMBus specific inputs

0 = Disable SMBus specific inputs

bit 5 **D/A:** Data/Address bit

In Master mode:

Reserved.

In Slave mode:

1 = Indicates that the last byte received or transmitted was data

0 = Indicates that the last byte received or transmitted was address

bit 4 **P:** Stop bit

1 = Indicates that a Stop bit has been detected last

0 = Stop bit was not detected last

Note: This bit is cleared on Reset and when SSPEN is cleared.

bit 3 **S:** Start bit

1 = Indicates that a Start bit has been detected last

0 = Start bit was not detected last

Note: This bit is cleared on Reset and when SSPEN is cleared.

bit 2 **R/W:** Read/Write bit Information (I²C mode only)

In Slave mode:

1 = Read

0 = Write

Note: This bit holds the R/W bit information following the last address match. This bit is only valid from the address match to the next Start bit, Stop bit, or not ACK bit.

In Master mode:

1 = Transmit is in progress

0 = Transmit is not in progress

Note: ORing this bit with SEN, RSEN, PEN, RCEN or ACKEN will indicate if the MSSP is in active mode.

bit 1 **UA:** Update Address bit (10-bit Slave mode only)

1 = Indicates that the user needs to update the address in the SSPADD register

0 = Address does not need to be updated

bit 0 **BF:** Buffer Full Status bit

In Transmit mode:

1 = SSPBUF is full

0 = SSPBUF is empty

In Receive mode:

1 = SSPBUF is full (does not include the ACK and Stop bits)

0 = SSPBUF is empty (does not include the ACK and Stop bits)

Legend:

R = Readable bit

W = Writable bit

U = Unimplemented bit, read as '0'

- n = Value at POR

'1' = Bit is set

'0' = Bit is cleared

x = Bit is unknown

PIC18F6520/8520/6620/8620/6720/8720

REGISTER 17-4: SSPCON1: MSSP CONTROL REGISTER 1 (I²C MODE)

R/W-0	R/W-0	R/W-0	R/W-0	R/W-0	R/W-0	R/W-0	R/W-0
WCOL	SSPOV	SSPEN	CKP	SSPM3	SSPM2	SSPM1	SSPM0

bit 7

bit 0

bit 7 **WCOL:** Write Collision Detect bit

In Master Transmit mode:

1 = A write to the SSPBUF register was attempted while the I²C conditions were not valid for a transmission to be started (must be cleared in software)

0 = No collision

In Slave Transmit mode:

1 = The SSPBUF register is written while it is still transmitting the previous word (must be cleared in software)

0 = No collision

In Receive mode (Master or Slave modes):

This is a “don’t care” bit.

bit 6 **SSPOV:** Receive Overflow Indicator bit

In Receive mode:

1 = A byte is received while the SSPBUF register is still holding the previous byte (must be cleared in software)

0 = No overflow

In Transmit mode:

This is a “don’t care” bit in Transmit mode.

bit 5 **SSPEN:** Synchronous Serial Port Enable bit

1 = Enables the serial port and configures the SDA and SCL pins as the serial port pins

0 = Disables serial port and configures these pins as I/O port pins

Note: When enabled, the SDA and SCL pins must be properly configured as input or output.

bit 4 **CKP:** SCK Release Control bit

In Slave mode:

1 = Release clock

0 = Holds clock low (clock stretch), used to ensure data setup time

In Master mode:

Unused in this mode.

bit 3-0 **SSPM3:SSPM0:** Synchronous Serial Port Mode Select bits

1111 = I²C Slave mode, 10-bit address with Start and Stop bit interrupts enabled

1110 = I²C Slave mode, 7-bit address with Start and Stop bit interrupts enabled

1011 = I²C Firmware Controlled Master mode (Slave Idle)

1000 = I²C Master mode, clock = FOSC/(4 * (SSPADD + 1))

0111 = I²C Slave mode, 10-bit address

0110 = I²C Slave mode, 7-bit address

Note: Bit combinations not specifically listed here are either reserved or implemented in SPI mode only.

Legend:

R = Readable bit

W = Writable bit

U = Unimplemented bit, read as ‘0’

- n = Value at POR

‘1’ = Bit is set

‘0’ = Bit is cleared

x = Bit is unknown

PIC18F6520/8520/6620/8620/6720/8720

REGISTER 17-5: SSPCON2: MSSP CONTROL REGISTER 2 (I²C MODE)

R/W-0	R/W-0	R/W-0	R/W-0	R/W-0	R/W-0	R/W-0	R/W-0
GCEN	ACKSTAT	ACKDT	ACKEN	RCEN	PEN	RSEN	SEN
bit 7							bit 0

- bit 7 **GCEN:** General Call Enable bit (Slave mode only)
 1 = Enable interrupt when a general call address (0000h) is received in the SSPSR
 0 = General call address disabled
- bit 6 **ACKSTAT:** Acknowledge Status bit (Master Transmit mode only)
 1 = Acknowledge was not received from slave
 0 = Acknowledge was received from slave
- bit 5 **ACKDT:** Acknowledge Data bit (Master Receive mode only)
 1 = Not Acknowledge
 0 = Acknowledge
- Note:** Value that will be transmitted when the user initiates an Acknowledge sequence at the end of a receive.
- bit 4 **ACKEN:** Acknowledge Sequence Enable bit (Master Receive mode only)
 1 = Initiate Acknowledge sequence on SDA and SCL pins and transmit ACKDT data bit. Automatically cleared by hardware.
 0 = Acknowledge sequence Idle
- bit 3 **RCEN:** Receive Enable bit (Master mode only)
 1 = Enables Receive mode for I²C
 0 = Receive Idle
- bit 2 **PEN:** Stop Condition Enable bit (Master mode only)
 1 = Initiate Stop condition on SDA and SCL pins. Automatically cleared by hardware.
 0 = Stop condition Idle
- bit 1 **RSEN:** Repeated Start Condition Enabled bit (Master mode only)
 1 = Initiate Repeated Start condition on SDA and SCL pins. Automatically cleared by hardware.
 0 = Repeated Start condition Idle
- bit 0 **SEN:** Start Condition Enabled/Stretch Enabled bit
- In Master mode:
 1 = Initiate Start condition on SDA and SCL pins. Automatically cleared by hardware.
 0 = Start condition Idle
- In Slave mode:
 1 = Clock stretching is enabled for both Slave Transmit and Slave Receive (stretch enabled)
 0 = Clock stretching is disabled

Note: For bits ACKEN, RCEN, PEN, RSEN, SEN: If the I²C module is not in the Idle mode, this bit may not be set (no spooling) and the SSPBUF may not be written (or writes to the SSPBUF are disabled).

Legend:

R = Readable bit W = Writable bit U = Unimplemented bit, read as '0'
 - n = Value at POR '1' = Bit is set '0' = Bit is cleared x = Bit is unknown

PIC18F6520/8520/6620/8620/6720/8720

17.4.2 OPERATION

The MSSP module functions are enabled by setting MSSP Enable bit, SSPEN (SSPCON<5>).

The SSPCON1 register allows control of the I²C operation. Four mode selection bits (SSPCON<3:0>) allow one of the following I²C modes to be selected:

- I²C Master mode, clock = (Fosc/4) x (SSPADD + 1)
- I²C Slave mode (7-bit address)
- I²C Slave mode (10-bit address)
- I²C Slave mode (7-bit address), with Start and Stop bit interrupts enabled
- I²C Slave mode (10-bit address), with Start and Stop bit interrupts enabled
- I²C Firmware Controlled Master mode, slave is Idle

Selection of any I²C mode, with the SSPEN bit set, forces the SCL and SDA pins to be open-drain, provided these pins are programmed to inputs by setting the appropriate TRISC bits. To ensure proper operation of the module, pull-up resistors must be provided externally to the SCL and SDA pins.

17.4.3 SLAVE MODE

In Slave mode, the SCL and SDA pins must be configured as inputs (TRISC<4:3> set). The MSSP module will override the input state with the output data when required (slave-transmitter).

The I²C Slave mode hardware will always generate an interrupt on an address match. Through the mode select bits, the user can also choose to interrupt on Start and Stop bits

When an address is matched or the data transfer after an address match is received, the hardware automatically will generate the Acknowledge (\overline{ACK}) pulse and load the SSPBUF register with the received value currently in the SSPSR register.

Any combination of the following conditions will cause the MSSP module not to give this \overline{ACK} pulse:

- The Buffer Full bit BF (SSPSTAT<0>) was set before the transfer was received.
- The overflow bit SSPOV (SSPCON<6>) was set before the transfer was received.

In this case, the SSPSR register value is not loaded into the SSPBUF, but bit SSPIF (PIR1<3>) is set. The BF bit is cleared by reading the SSPBUF register, while bit SSPOV is cleared through software.

The SCL clock input must have a minimum high and low for proper operation. The high and low times of the I²C specification, as well as the requirement of the MSSP module, are shown in timing parameter #100 and parameter #101.

17.4.3.1 Addressing

Once the MSSP module has been enabled, it waits for a Start condition to occur. Following the Start condition, the 8 bits are shifted into the SSPSR register. All incoming bits are sampled with the rising edge of the clock (SCL) line. The value of register SSPSR<7:1> is compared to the value of the SSPADD register. The address is compared on the falling edge of the eighth clock (SCL) pulse. If the addresses match and the BF and SSPOV bits are clear, the following events occur:

1. The SSPSR register value is loaded into the SSPBUF register.
2. The Buffer Full bit BF is set.
3. An \overline{ACK} pulse is generated.
4. MSSP Interrupt Flag bit, SSPIF (PIR1<3>), is set (interrupt is generated, if enabled) on the falling edge of the ninth SCL pulse.

In 10-bit Address mode, two address bytes need to be received by the slave. The five Most Significant bits (MSBs) of the first address byte specify if this is a 10-bit address. Bit R/W (SSPSTAT<2>) must specify a write so the slave device will receive the second address byte. For a 10-bit address, the first byte would equal '11110 A9 A8 0', where 'A9' and 'A8' are the two MSBs of the address. The sequence of events for 10-bit address is as follows, with steps 7 through 9 for the slave-transmitter:

1. Receive first (high) byte of address (bits SSPIF, BF and bit UA (SSPSTAT<1>) are set).
2. Update the SSPADD register with second (low) byte of address (clears bit UA and releases the SCL line).
3. Read the SSPBUF register (clears bit BF) and clear flag bit SSPIF.
4. Receive second (low) byte of address (bits SSPIF, BF and UA are set).
5. Update the SSPADD register with the first (high) byte of address. If match releases SCL line, this will clear bit UA.
6. Read the SSPBUF register (clears bit BF) and clear flag bit SSPIF.
7. Receive Repeated Start condition.
8. Receive first (high) byte of address (bits SSPIF and BF are set).
9. Read the SSPBUF register (clears bit BF) and clear flag bit SSPIF.

PIC18F6520/8520/6620/8620/6720/8720

17.4.3.2 Reception

When the $\overline{R/W}$ bit of the address byte is clear and an address match occurs, the $\overline{R/W}$ bit of the SSPSTAT register is cleared. The received address is loaded into the SSPBUF register and the SDA line is held low (\overline{ACK}).

When the address byte overflow condition exists, then the no Acknowledge (\overline{ACK}) pulse is given. An overflow condition is defined as either bit BF (SSPSTAT<0>) is set, or bit SSPOV (SSPCON1<6>) is set.

An MSSP interrupt is generated for each data transfer byte. Flag bit SSPIF (PIR1<3>) must be cleared in software. The SSPSTAT register is used to determine the status of the byte.

If SEN is enabled (SSPCON1<0> = 1), RC3/SCK/SCL will be held low (clock stretch) following each data transfer. The clock must be released by setting bit CKP (SSPCON<4>). See **Section 17.4.4 “Clock Stretching”** for more detail.

17.4.3.3 Transmission

When the $\overline{R/W}$ bit of the incoming address byte is set and an address match occurs, the $\overline{R/W}$ bit of the SSPSTAT register is set. The received address is loaded into the SSPBUF register. The \overline{ACK} pulse will be sent on the ninth bit and pin RC3/SCK/SCL is held low, regardless of SEN (see **Section 17.4.4 “Clock Stretching”**, for more detail). By stretching the clock, the master will be unable to assert another clock pulse until the slave is done preparing the transmit data. The transmit data must be loaded into the SSPBUF register, which also loads the SSPSR register. Then pin RC3/SCK/SCL should be enabled by setting bit CKP (SSPCON1<4>). The eight data bits are shifted out on the falling edge of the SCL input. This ensures that the SDA signal is valid during the SCL high time (Figure 17-9).

The \overline{ACK} pulse from the master-receiver is latched on the rising edge of the ninth SCL input pulse. If the SDA line is high (not \overline{ACK}), then the data transfer is complete. In this case, when the \overline{ACK} is latched by the slave, the slave logic is reset (resets SSPSTAT register) and the slave monitors for another occurrence of the Start bit. If the SDA line was low (\overline{ACK}), the next transmit data must be loaded into the SSPBUF register. Again, pin RC3/SCK/SCL must be enabled by setting bit CKP.

An MSSP interrupt is generated for each data transfer byte. The SSPIF bit must be cleared in software and the SSPSTAT register is used to determine the status of the byte. The SSPIF bit is set on the falling edge of the ninth clock pulse.

FIGURE 17-8: I²C SLAVE MODE TIMING WITH SEN = 0 (RECEPTION, 7-BIT ADDRESS)

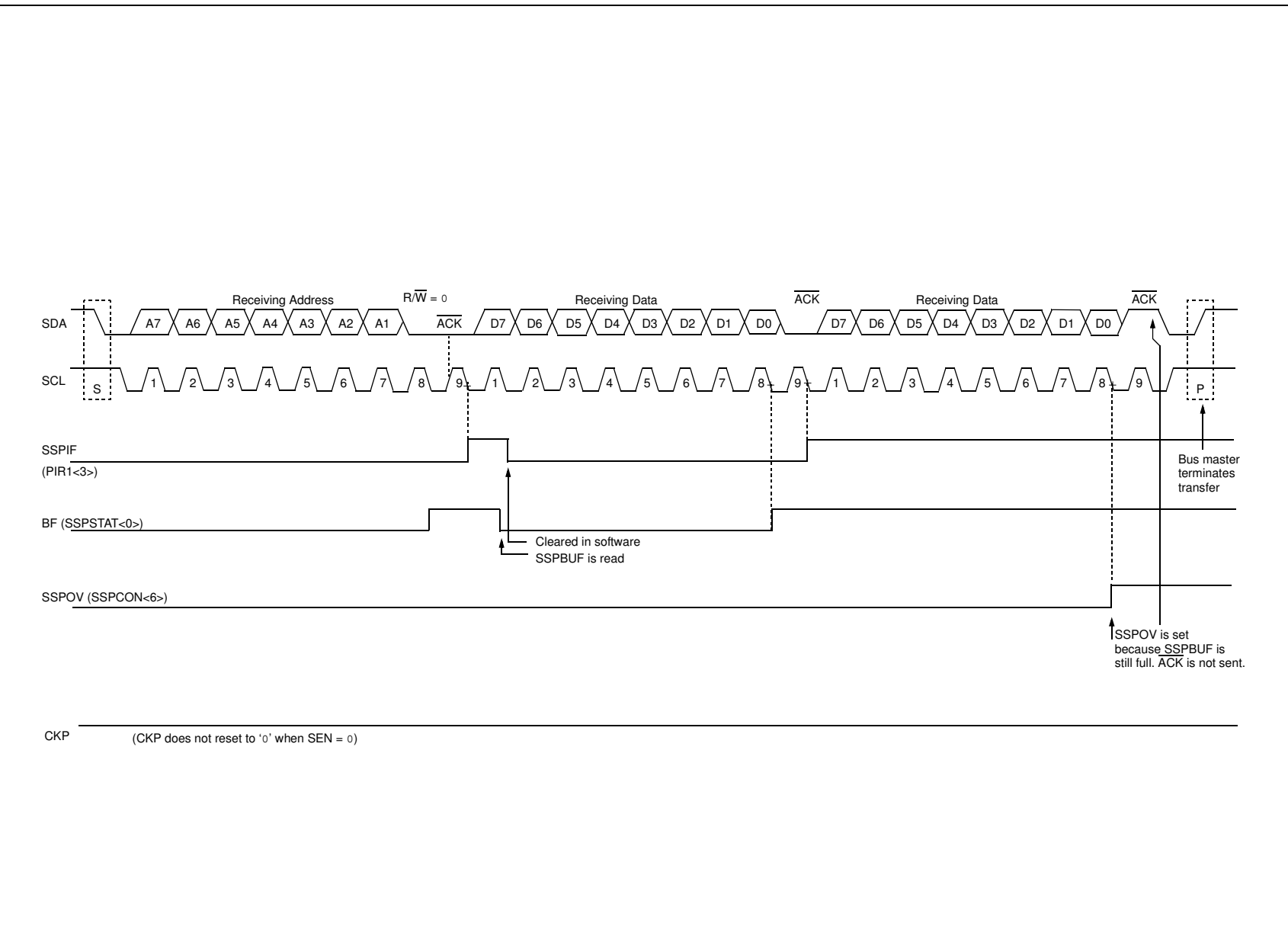

FIGURE 17-9: I²C SLAVE MODE TIMING (TRANSMISSION, 7-BIT ADDRESS)

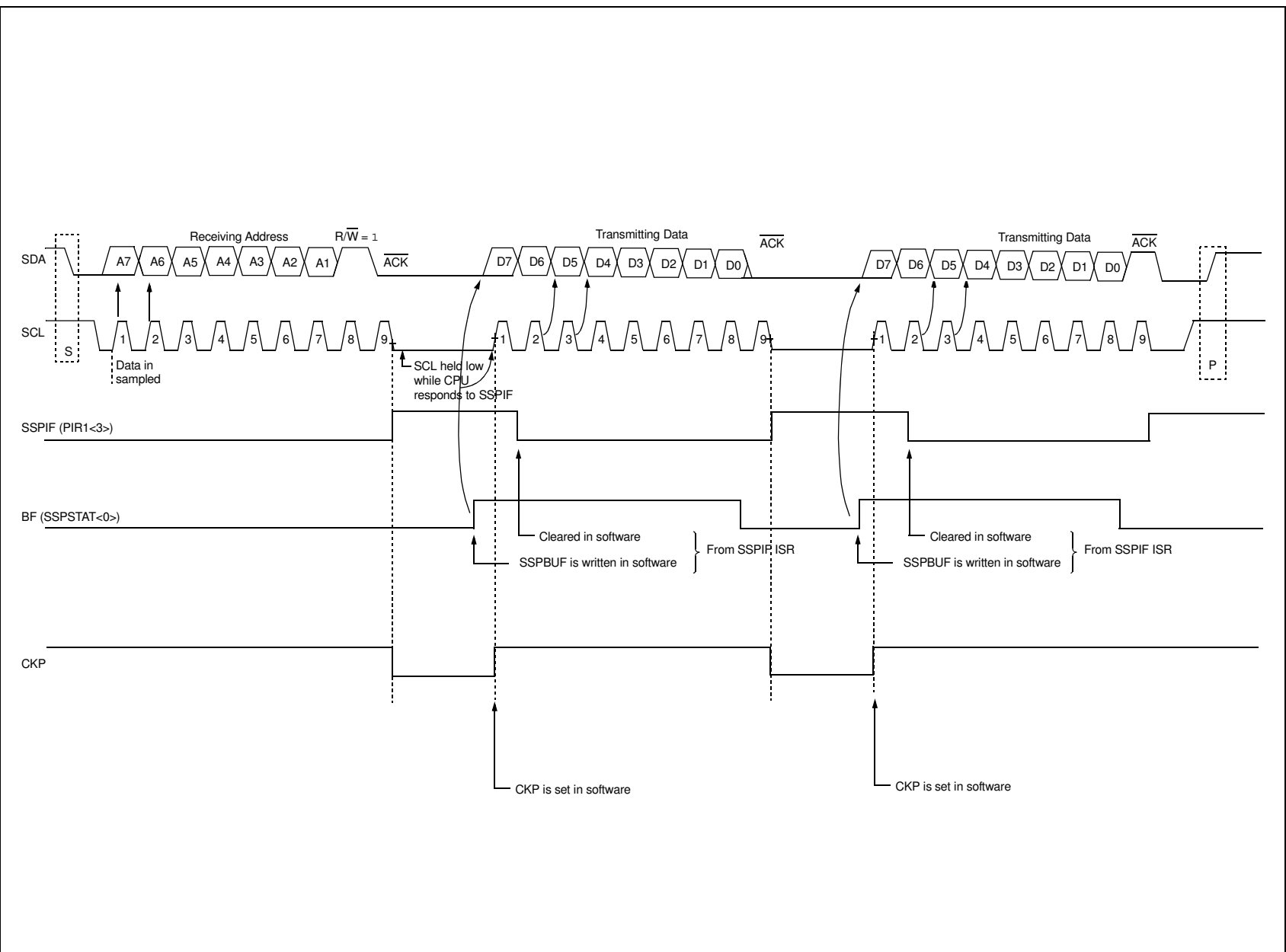

FIGURE 17-10: I²C SLAVE MODE TIMING WITH SEN = 0 (RECEPTION, 10-BIT ADDRESS)

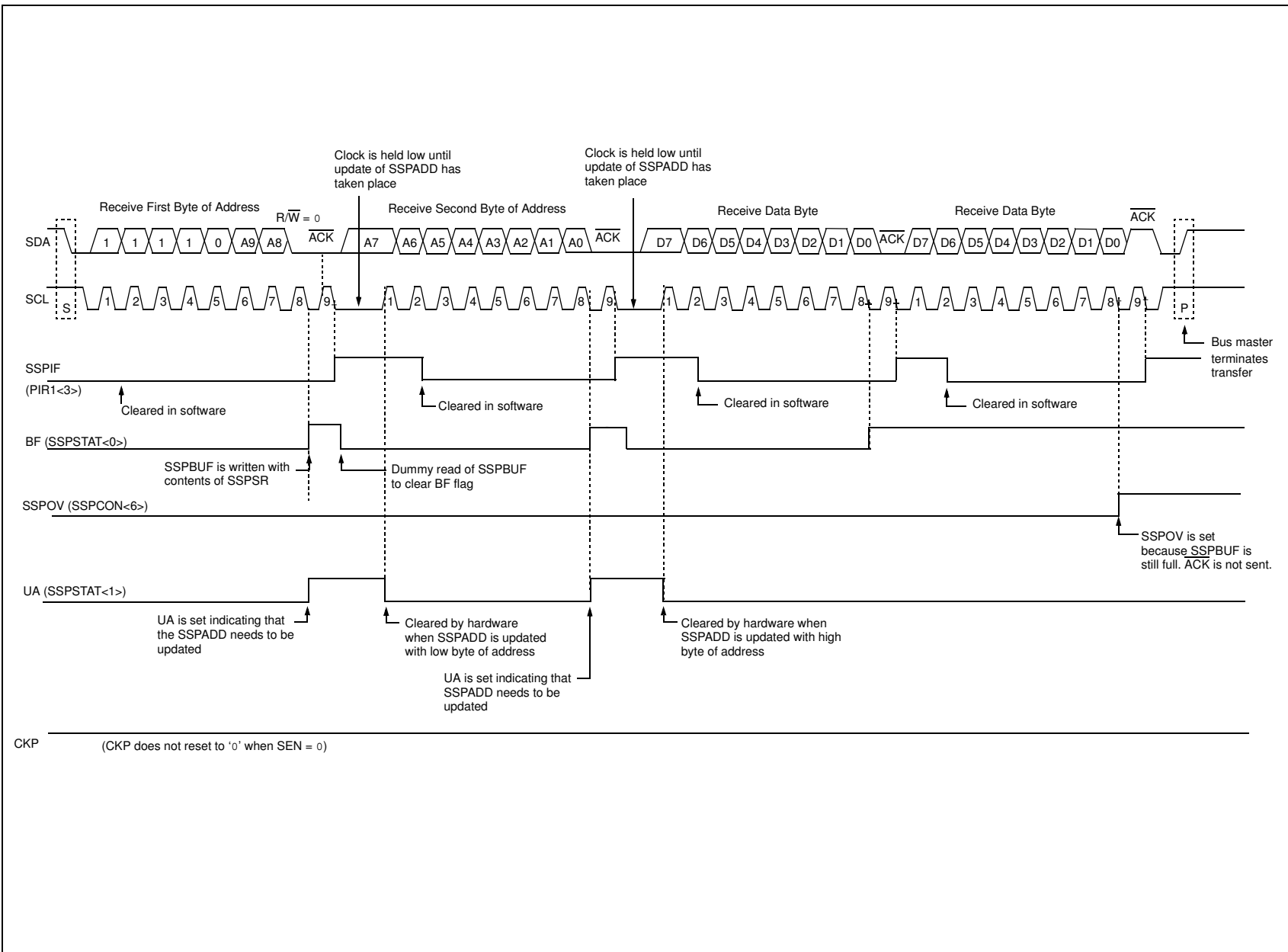
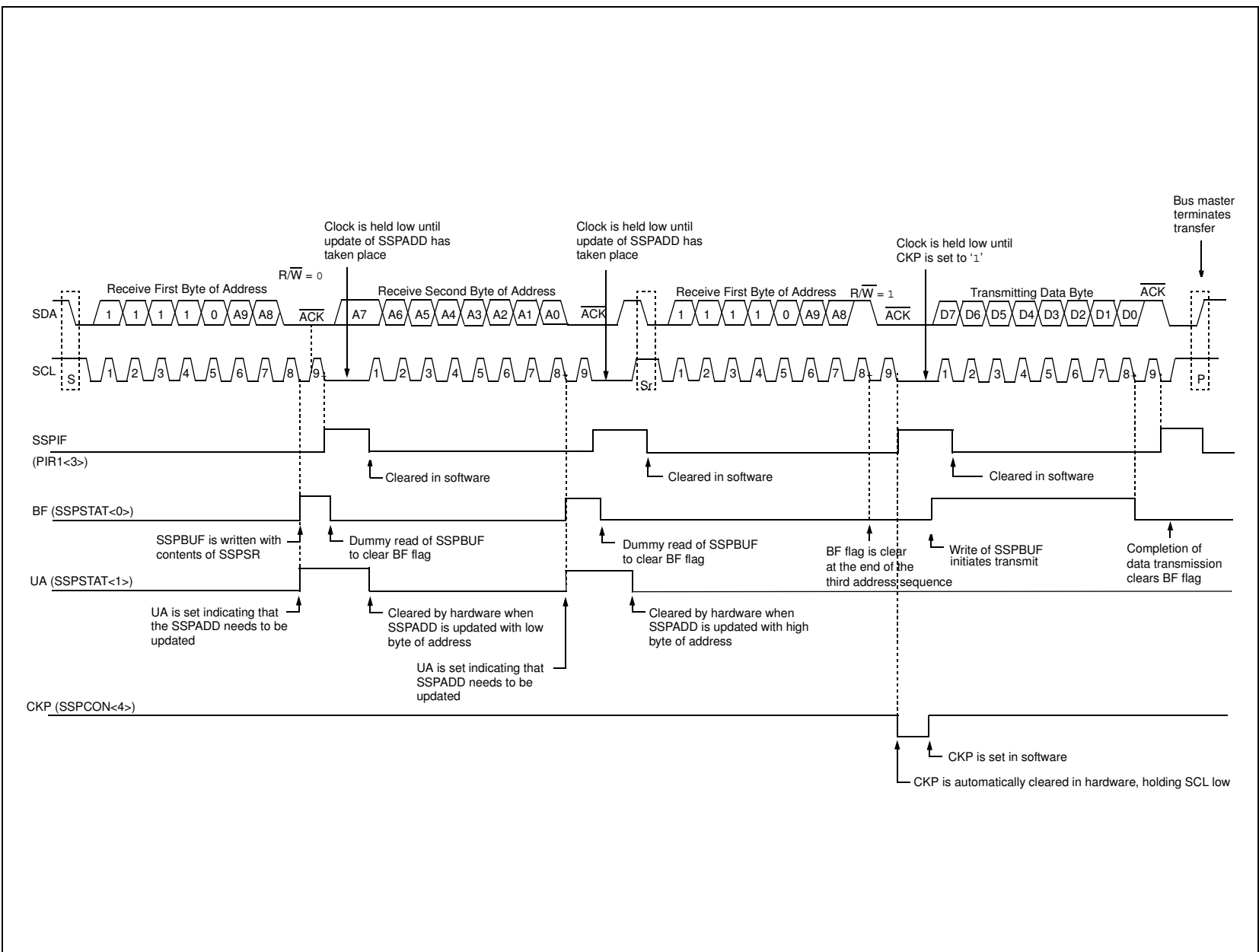

FIGURE 17-11: I²C SLAVE MODE TIMING (TRANSMISSION, 10-BIT ADDRESS)



PIC18F6520/8520/6620/8620/6720/8720

17.4.4 CLOCK STRETCHING

Both 7- and 10-bit Slave modes implement automatic clock stretching during a transmit sequence.

The SEN bit (SSPCON2<0>) allows clock stretching to be enabled during receives. Setting SEN will cause the SCL pin to be held low at the end of each data receive sequence.

17.4.4.1 Clock Stretching for 7-bit Slave Receive Mode (SEN = 1)

In 7-bit Slave Receive mode, on the falling edge of the ninth clock at the end of the ACK sequence, if the BF bit is set, the CKP bit in the SSPCON1 register is automatically cleared, forcing the SCL output to be held low. The CKP being cleared to '0' will assert the SCL line low. The CKP bit must be set in the user's ISR before reception is allowed to continue. By holding the SCL line low, the user has time to service the ISR and read the contents of the SSPBUF before the master device can initiate another receive sequence. This will prevent buffer overruns from occurring (see Figure 17-13).

Note 1: If the user reads the contents of the SSPBUF before the falling edge of the ninth clock, thus clearing the BF bit, the CKP bit will not be cleared and clock stretching will not occur.

2: The CKP bit can be set in software, regardless of the state of the BF bit. The user should be careful to clear the BF bit in the ISR before the next receive sequence, in order to prevent an overflow condition.

17.4.4.2 Clock Stretching for 10-bit Slave Receive Mode (SEN = 1)

In 10-bit Slave Receive mode, during the address sequence, clock stretching automatically takes place but CKP is not cleared. During this time, if the UA bit is set after the ninth clock, clock stretching is initiated. The UA bit is set after receiving the upper byte of the 10-bit address and following the receive of the second byte of the 10-bit address with the R/W bit cleared to '0'. The release of the clock line occurs upon updating SSPADD. Clock stretching will occur on each data receive sequence, as described in 7-bit mode.

Note: If the user polls the UA bit and clears it by updating the SSPADD register before the falling edge of the ninth clock occurs and if the user hasn't cleared the BF bit by reading the SSPBUF register before that time, then the CKP bit will still NOT be asserted low. Clock stretching on the basis of the state of the BF bit only occurs during a data sequence, not an address sequence.

17.4.4.3 Clock Stretching for 7-bit Slave Transmit Mode

7-bit Slave Transmit mode implements clock stretching by clearing the CKP bit after the falling edge of the ninth clock, if the BF bit is clear. This occurs, regardless of the state of the SEN bit.

The user's ISR must set the CKP bit before transmission is allowed to continue. By holding the SCL line low, the user has time to service the ISR and load the contents of the SSPBUF before the master device can initiate another transmit sequence (see Figure 17-9).

Note 1: If the user loads the contents of SSPBUF, setting the BF bit before the falling edge of the ninth clock, the CKP bit will not be cleared and clock stretching will not occur.

2: The CKP bit can be set in software, regardless of the state of the BF bit.

17.4.4.4 Clock Stretching for 10-bit Slave Transmit Mode

In 10-bit Slave Transmit mode, clock stretching is controlled during the first two address sequences by the state of the UA bit, just as it is in 10-bit Slave Receive mode. The first two addresses are followed by a third address sequence, which contains the high-order bits of the 10-bit address and the R/W bit set to '1'. After the third address sequence is performed, the UA bit is not set, the module is now configured in Transmit mode and clock stretching is controlled as in 7-bit Slave Transmit mode (see Figure 17-11).

PIC18F6520/8520/6620/8620/6720/8720

17.4.4.5 Clock Synchronization and the CKP bit

When the CKP bit is cleared, the SCL output is forced to '0'. However, clearing the CKP bit will not assert the SCL output low until the SCL output is already sampled low. Therefore, the CKP bit will not assert the SCL line until an external I²C master device has

already asserted the SCL line. The SCL output will remain low until the CKP bit is set and all other devices on the I²C bus have deasserted SCL. This ensures that a write to the CKP bit will not violate the minimum high time requirement for SCL (see Figure 17-12).

FIGURE 17-12: CLOCK SYNCHRONIZATION TIMING

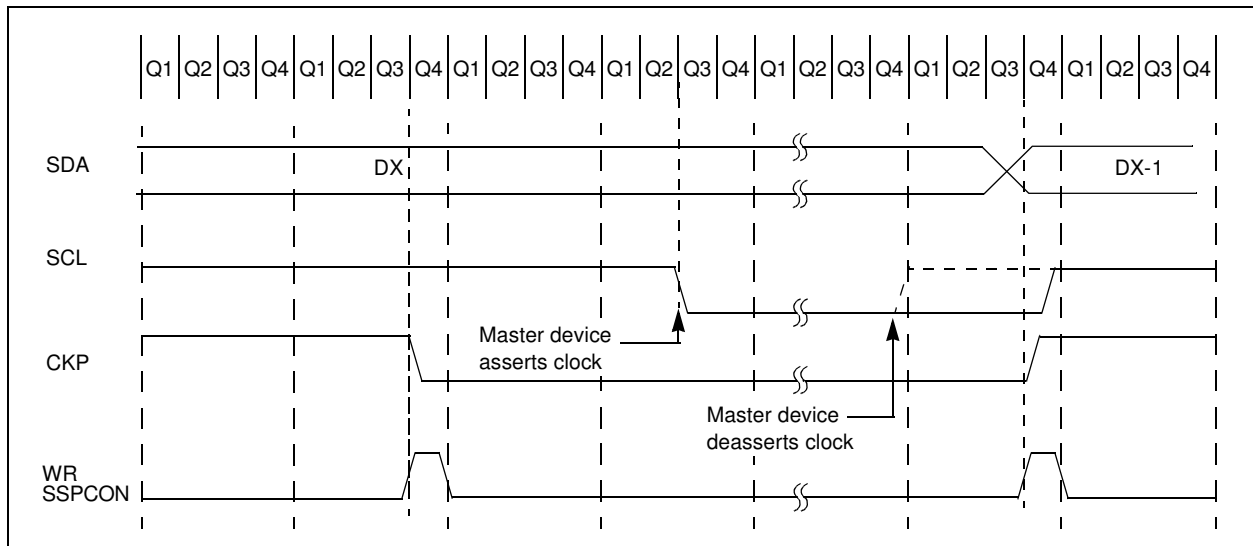

FIGURE 17-13: I²C SLAVE MODE TIMING WITH SEN = 1 (RECEPTION, 7-BIT ADDRESS)

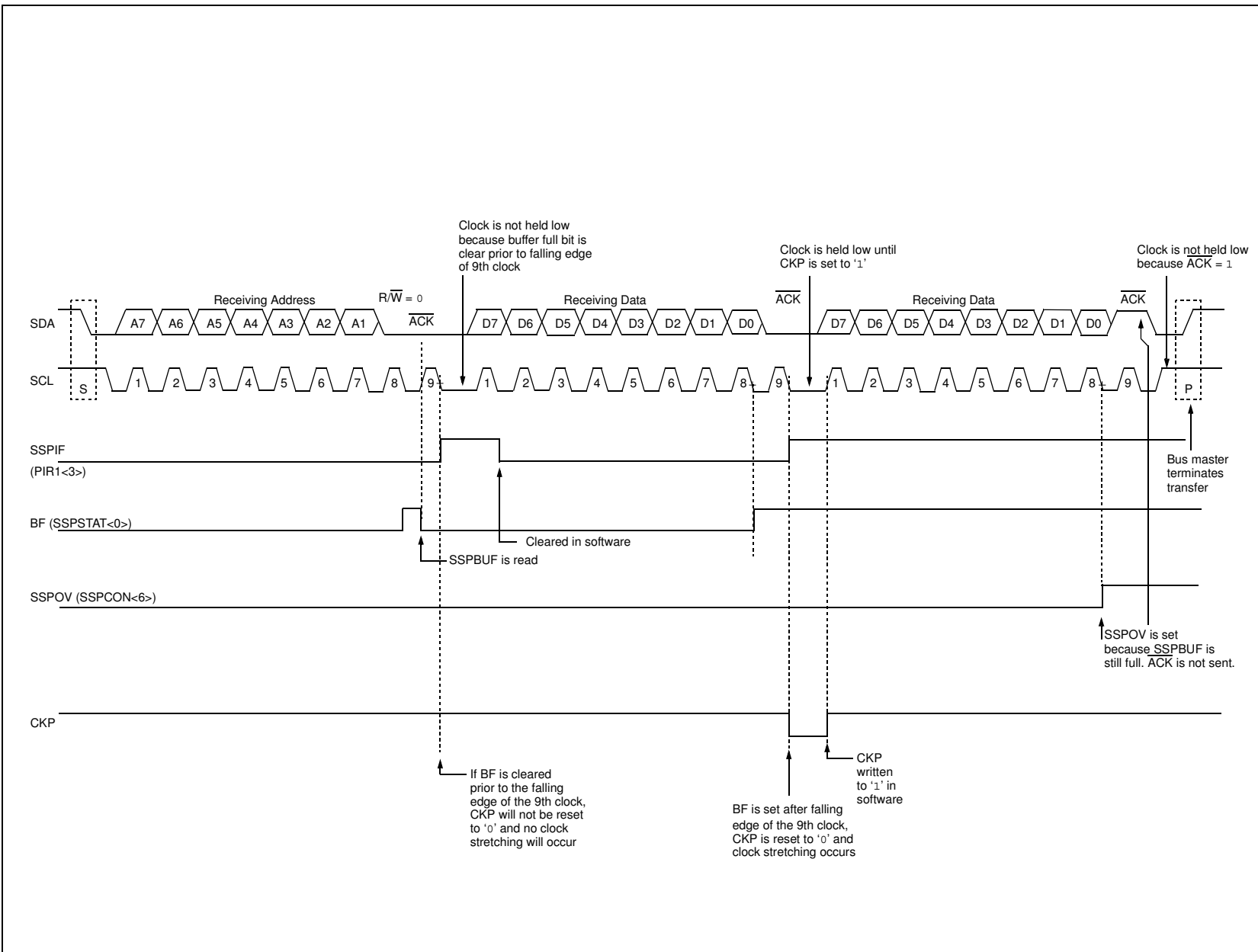
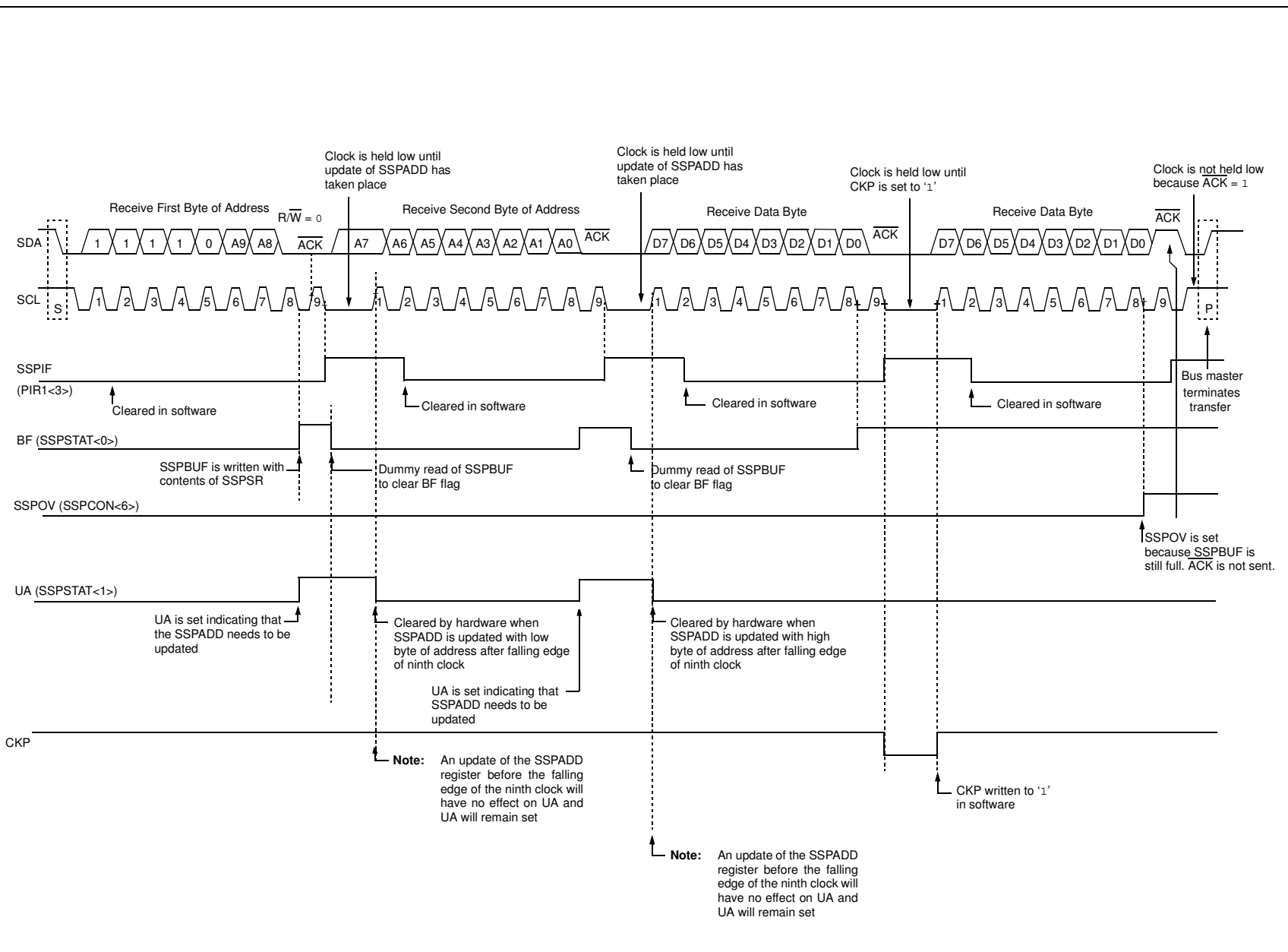

FIGURE 17-14: I²C SLAVE MODE TIMING SEN = 1 (RECEPTION, 10-BIT ADDRESS)



PIC18F6520/8520/6620/8620/6720/8720

17.4.5 GENERAL CALL ADDRESS SUPPORT

The addressing procedure for the I²C bus is such that the first byte after the Start condition usually determines which device will be the slave addressed by the master. The exception is the general call address, which can address all devices. When this address is used, all devices should, in theory, respond with an Acknowledge.

The general call address is one of eight addresses reserved for specific purposes by the I²C protocol. It consists of all '0's with R/W = 0.

The general call address is recognized when the General Call Enable bit (GCEN) is enabled (SSPCON2<7> set). Following a Start bit detect, 8 bits are shifted into the SSPSR and the address is compared against the SSPADD. It is also compared to the general call address and fixed in hardware.

If the general call address matches, the SSPSR is transferred to the SSPBUF, the BF flag bit is set (eighth bit) and on the falling edge of the ninth bit ($\overline{\text{ACK}}$ bit), the SSPIF interrupt flag bit is set.

When the interrupt is serviced, the source for the interrupt can be checked by reading the contents of the SSPBUF. The value can be used to determine if the address was device specific or a general call address.

In 10-bit mode, the SSPADD is required to be updated for the second half of the address to match and the UA bit is set (SSPSTAT<1>). If the general call address is sampled when the GCEN bit is set, while the slave is configured in 10-bit Address mode, then the second half of the address is not necessary, the UA bit will not be set and the slave will begin receiving data after the Acknowledge (Figure 17-15).

FIGURE 17-15: SLAVE MODE GENERAL CALL ADDRESS SEQUENCE (7 OR 10-BIT ADDRESS MODE)

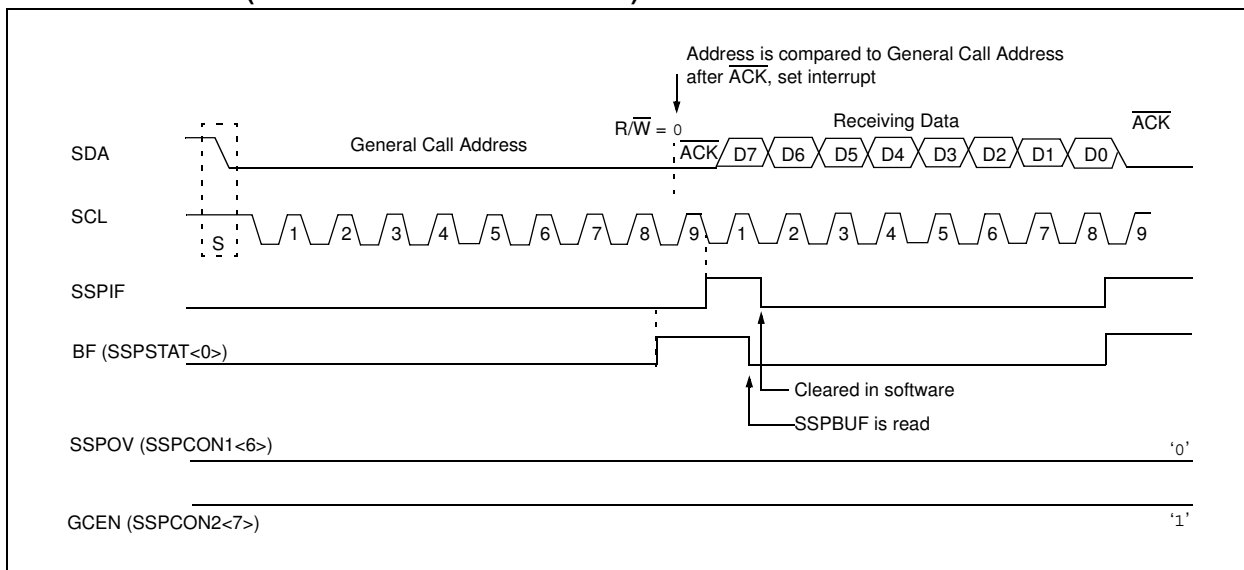

PIC18F6520/8520/6620/8620/6720/8720

17.4.6 MASTER MODE

Master mode is enabled by setting and clearing the appropriate SSPM bits in SSPCON1 and by setting the SSPEN bit. In Master mode, the SCL and SDA lines are manipulated by the MSSP hardware.

Master mode of operation is supported by interrupt generation on the detection of the Start and Stop conditions. The Stop (P) and Start (S) bits are cleared from a Reset, or when the MSSP module is disabled. Control of the I²C bus may be taken when the P bit is set or the bus is Idle, with both the S and P bits clear.

In Firmware Controlled Master mode, user code conducts all I²C bus operations based on Start and Stop bit conditions.

Once Master mode is enabled, the user has six options.

1. Assert a Start condition on SDA and SCL.
2. Assert a Repeated Start condition on SDA and SCL.
3. Write to the SSPBUF register initiating transmission of data/address.
4. Configure the I²C port to receive data.
5. Generate an Acknowledge condition at the end of a received byte of data.
6. Generate a Stop condition on SDA and SCL.

Note: The MSSP module, when configured in I²C Master mode, does not allow queuing of events. For instance, the user is not allowed to initiate a Start condition and immediately write the SSPBUF register to initiate transmission before the Start condition is complete. In this case, the SSPBUF will not be written to and the WCOL bit will be set, indicating that a write to the SSPBUF did not occur.

The following events will cause SSP Interrupt Flag bit, SSPIF, to be set (SSP interrupt if enabled):

- Start Condition
- Stop Condition
- Data Transfer Byte Transmitted/received
- Acknowledge Transmit
- Repeated Start

FIGURE 17-16: MSSP BLOCK DIAGRAM (I²C MASTER MODE)

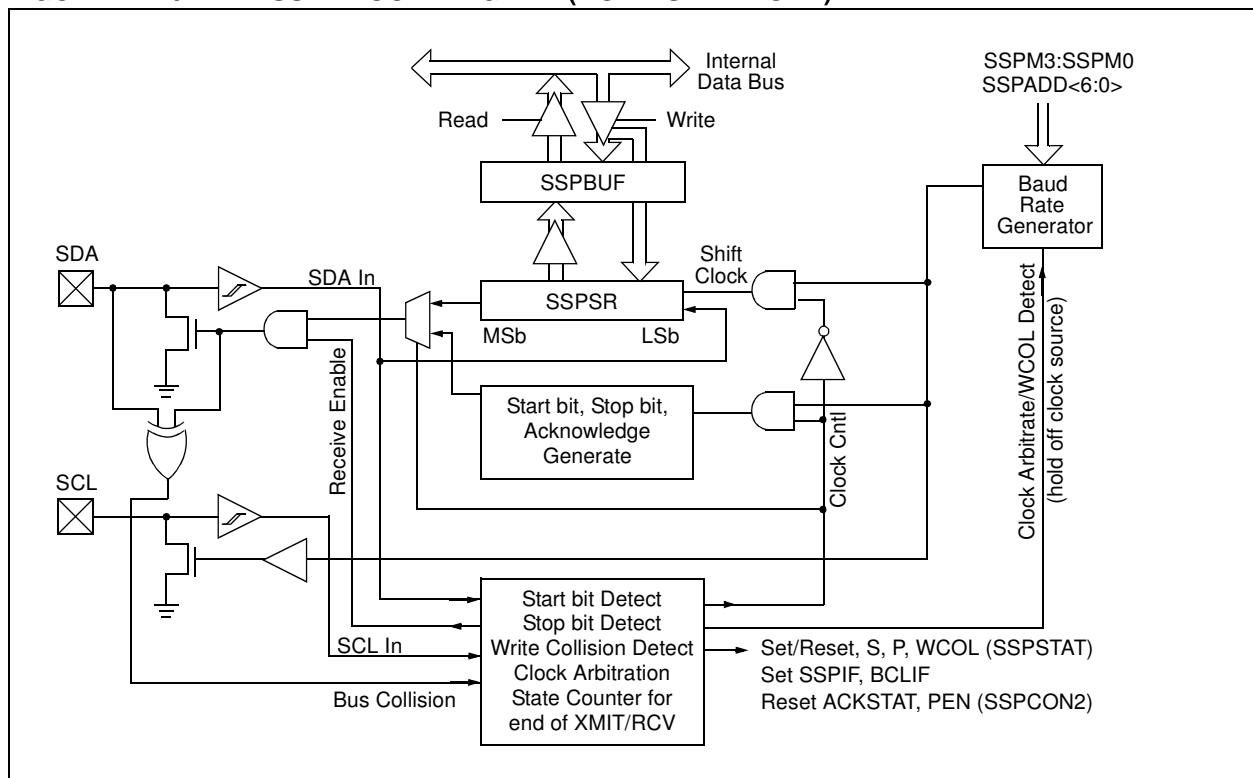

PIC18F6520/8520/6620/8620/6720/8720

17.4.6.1 I²C Master Mode Operation

The master device generates all of the serial clock pulses and the Start and Stop conditions. A transfer is ended with a Stop condition or with a Repeated Start condition. Since the Repeated Start condition is also the beginning of the next serial transfer, the I²C bus will not be released.

In Master Transmitter mode, serial data is output through SDA, while SCL outputs the serial clock. The first byte transmitted contains the slave address of the receiving device (7 bits) and the Read/Write (R/W) bit. In this case, the R/W bit will be logic '0'. Serial data is transmitted 8 bits at a time. After each byte is transmitted, an Acknowledge bit is received. Start and Stop conditions are output to indicate the beginning and the end of a serial transfer.

In Master Receive mode, the first byte transmitted contains the slave address of the transmitting device (7 bits) and the R/W bit. In this case, the R/W bit will be logic '1'. Thus, the first byte transmitted is a 7-bit slave address followed by a '1' to indicate receive bit. Serial data is received via SDA, while SCL outputs the serial clock. Serial data is received 8 bits at a time. After each byte is received, an Acknowledge bit is transmitted. Start and Stop conditions indicate the beginning and end of transmission.

The Baud Rate Generator used for the SPI mode operation is used to set the SCL clock frequency for either 100 kHz, 400 kHz or 1 MHz I²C operation. See **Section 17.4.7 "Baud Rate Generator"**, for more information.

A typical transmit sequence would go as follows:

1. The user generates a Start condition by setting the Start enable bit, SEN (SSPCON2<0>).
2. SSPIF is set. The MSSP module will wait the required start time before any other operation takes place.
3. The user loads the SSPBUF with the slave address to transmit.
4. Address is shifted out the SDA pin until all 8 bits are transmitted.
5. The MSSP module shifts in the ACK bit from the slave device and writes its value into the SSPCON2 register (SSPCON2<6>).
6. The MSSP module generates an interrupt at the end of the ninth clock cycle by setting the SSPIF bit.
7. The user loads the SSPBUF with eight bits of data.
8. Data is shifted out the SDA pin until all 8 bits are transmitted.
9. The MSSP module shifts in the ACK bit from the slave device and writes its value into the SSPCON2 register (SSPCON2<6>).
10. The MSSP module generates an interrupt at the end of the ninth clock cycle by setting the SSPIF bit.
11. The user generates a Stop condition by setting the Stop enable bit PEN (SSPCON2<2>).
12. Interrupt is generated once the Stop condition is complete.

PIC18F6520/8520/6620/8620/6720/8720

17.4.7 BAUD RATE GENERATOR

In I²C Master mode, the Baud Rate Generator (BRG) reload value is placed in the lower 7 bits of the SSPADD register (Figure 17-17). When a write occurs to SSPBUF, the Baud Rate Generator will automatically begin counting. The BRG counts down to '0' and stops until another reload has taken place. The BRG count is decremented twice per instruction cycle (TCY) on the Q2 and Q4 clocks. In I²C Master mode, the BRG is reloaded automatically.

Once the given operation is complete (i.e., transmission of the last data bit is followed by ACK), the internal clock will automatically stop counting and the SCL pin will remain in its last state.

Table 15-3 demonstrates clock rates based on instruction cycles and the BRG value loaded into SSPADD.

FIGURE 17-17: BAUD RATE GENERATOR BLOCK DIAGRAM

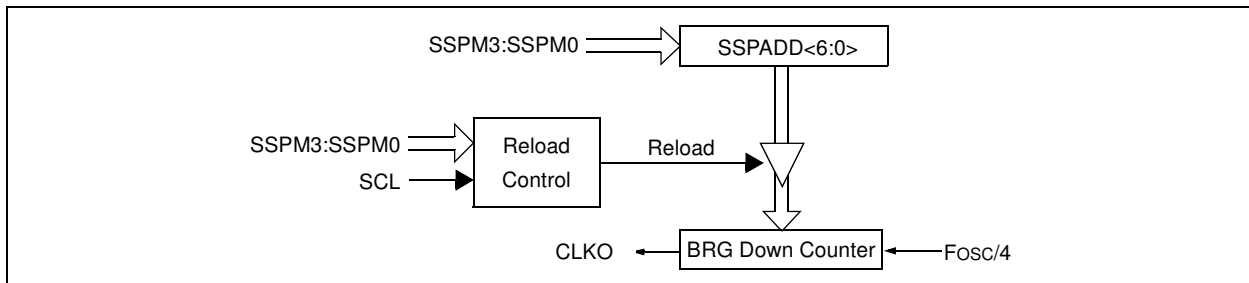

TABLE 17-3: I²C CLOCK RATE W/BRG

Fcy	Fcy*2	BRG VALUE	Fscl (2 rollovers of BRG)
10 MHz	20 MHz	19h	400 kHz ⁽¹⁾
10 MHz	20 MHz	20h	312.5 kHz
10 MHz	20 MHz	3Fh	100 kHz
4 MHz	8 MHz	0Ah	400 kHz ⁽¹⁾
4 MHz	8 MHz	0Dh	308 kHz
4 MHz	8 MHz	28h	100 kHz
1 MHz	2 MHz	03h	333 kHz ⁽¹⁾
1 MHz	2 MHz	0Ah	100 kHz
1 MHz	2 MHz	00h	1 MHz ⁽¹⁾

Note 1: The I²C interface does not conform to the 400 kHz I²C specification (which applies to rates greater than 100 kHz) in all details, but may be used with care where higher rates are required by the application.

PIC18F6520/8520/6620/8620/6720/8720

17.4.7.1 Clock Arbitration

Clock arbitration occurs when the master, during any receive, transmit or Repeated Start/Stop condition, deasserts the SCL pin (SCL allowed to float high). When the SCL pin is allowed to float high, the Baud Rate Generator (BRG) is suspended from counting until the SCL pin is actually sampled high. When the

SCL pin is sampled high, the Baud Rate Generator is reloaded with the contents of SSPADD<6:0> and begins counting. This ensures that the SCL high time will always be at least one BRG rollover count, in the event that the clock is held low by an external device (Figure 15-18).

FIGURE 17-18: BAUD RATE GENERATOR TIMING WITH CLOCK ARBITRATION

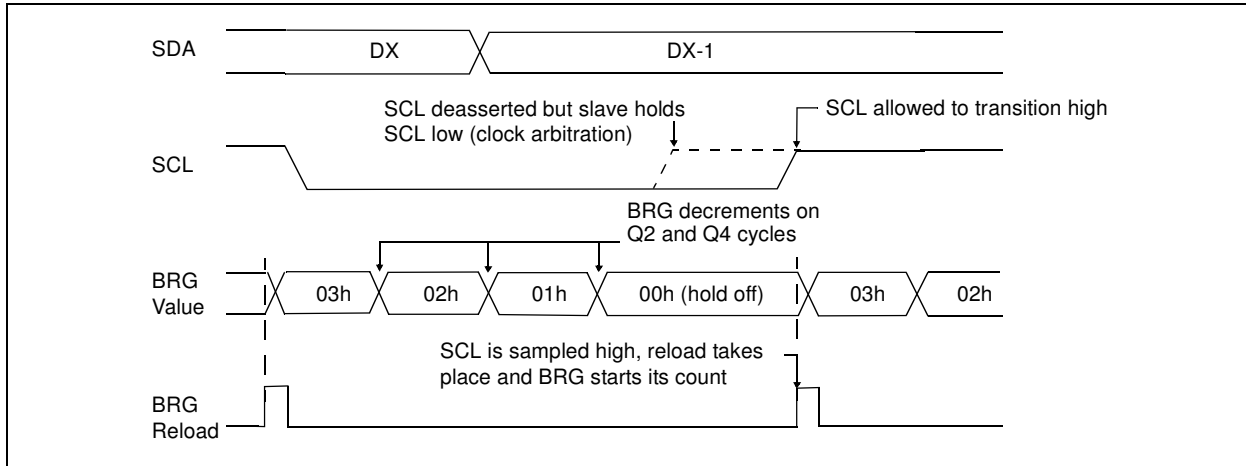

PIC18F6520/8520/6620/8620/6720/8720

17.4.8 I²C MASTER MODE START CONDITION TIMING

To initiate a Start condition, the user sets the Start Condition Enable bit, SEN (SSPCON2<0>). If the SDA and SCL pins are sampled high, the Baud Rate Generator is reloaded with the contents of SSPADD<6:0> and starts its count. If SCL and SDA are both sampled high when the Baud Rate Generator times out (TBRG), the SDA pin is driven low. The action of the SDA being driven low, while SCL is high, is the Start condition and causes the S bit (SSPSTAT<3>) to be set. Following this, the Baud Rate Generator is reloaded with the contents of SSPADD<6:0> and resumes its count. When the Baud Rate Generator times out (TBRG), the SEN bit (SSPCON2<0>) will be automatically cleared by hardware, the Baud Rate Generator is suspended, leaving the SDA line held low and the Start condition is complete.

Note: If at the beginning of the Start condition, the SDA and SCL pins are already sampled low, or if during the Start condition the SCL line is sampled low before the SDA line is driven low, a bus collision occurs, the Bus Collision Interrupt Flag, BCLIF, is set, the Start condition is aborted and the I²C module is reset into its Idle state.

17.4.8.1 WCOL Status Flag

If the user writes the SSPBUF when a Start sequence is in progress, the WCOL is set and the contents of the buffer are unchanged (the write doesn't occur).

Note: Because queueing of events is not allowed, writing to the lower 5 bits of SSPCON2 is disabled until the Start condition is complete.

FIGURE 17-19: FIRST START BIT TIMING

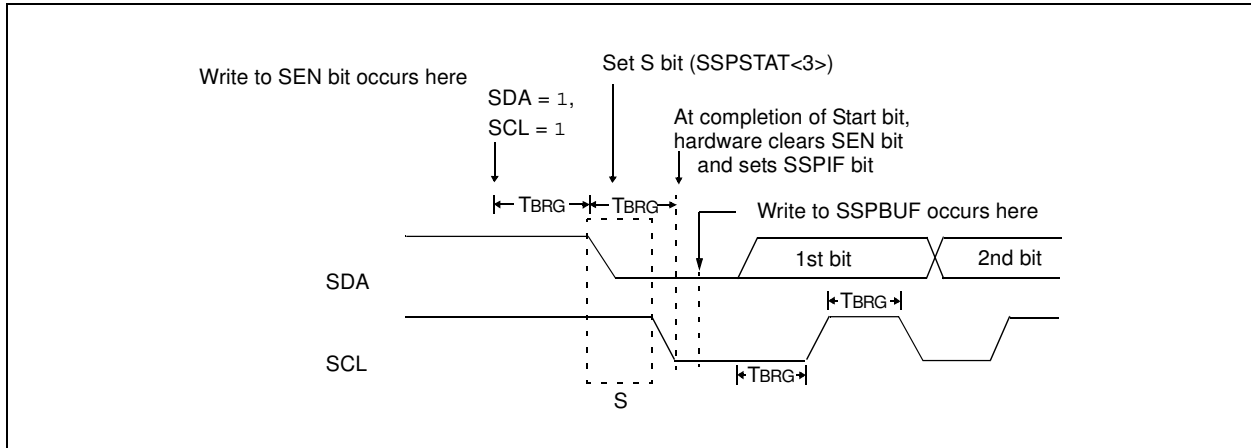

17.4.10 I²C MASTER MODE TRANSMISSION

Transmission of a data byte, a 7-bit address, or the other half of a 10-bit address is accomplished by simply writing a value to the SSPBUF register. This action will set the Buffer Full flag bit, BF and allow the Baud Rate Generator to begin counting and start the next transmission. Each bit of address/data will be shifted out onto the SDA pin after the falling edge of SCL is asserted (see data hold time specification parameter #106). SCL is held low for one Baud Rate Generator rollover count (TBRG). Data should be valid before SCL is released high (see data setup time specification parameter #107). When the SCL pin is released high, it is held that way for TBRG. The data on the SDA pin must remain stable for that duration and some hold time, after the next falling edge of SCL. After the eighth bit is shifted out (the falling edge of the eighth clock), the BF flag is cleared and the master releases SDA. This allows the slave device being addressed to respond with an $\overline{\text{ACK}}$ bit during the ninth bit time if an address match occurred, or if data was received properly. The status of $\overline{\text{ACK}}$ is written into the ACKDT bit on the falling edge of the ninth clock. If the master receives an Acknowledge, the Acknowledge Status bit, ACKSTAT, is cleared. If not, the bit is set. After the ninth clock, the SSPIF bit is set and the master clock (Baud Rate Generator) is suspended until the next data byte is loaded into the SSPBUF, leaving SCL low and SDA unchanged (Figure 17-21).

After the write to the SSPBUF, each address bit will be shifted out on the falling edge of SCL, until all seven address bits and the R/W bit are completed. On the falling edge of the eighth clock, the master will deassert the SDA pin, allowing the slave to respond with an Acknowledge. On the falling edge of the ninth clock, the master will sample the SDA pin to see if the address was recognized by a slave. The status of the $\overline{\text{ACK}}$ bit is loaded into the ACKSTAT status bit (SSPCON2<6>). Following the falling edge of the ninth clock transmission of the address, the SSPIF is set, the BF flag is cleared and the Baud Rate Generator is turned off until another write to the SSPBUF takes place, holding SCL low and allowing SDA to float.

17.4.10.1 BF Status Flag

In Transmit mode, the BF bit (SSPSTAT<0>) is set when the CPU writes to SSPBUF and is cleared when all 8 bits are shifted out.

17.4.10.2 WCOL Status Flag

If the user writes the SSPBUF when a transmit is already in progress (i.e., SSPSR is still shifting out a data byte), the WCOL is set and the contents of the buffer are unchanged (the write doesn't occur).

WCOL must be cleared in software.

17.4.10.3 ACKSTAT Status Flag

In Transmit mode, the ACKSTAT bit (SSPCON2<6>) is cleared when the slave has sent an Acknowledge ($\overline{\text{ACK}} = 0$) and is set when the slave does not Acknowledge ($\overline{\text{ACK}} = 1$). A slave sends an Acknowledge when it has recognized its address (including a general call), or when the slave has properly received its data.

17.4.11 I²C MASTER MODE RECEPTION

Master mode reception is enabled by programming the Receive Enable bit, RCEN (SSPCON2<3>).

Note: The MSSP module must be in an Idle state before the RCEN bit is set, or the RCEN bit will be disregarded.
--

The Baud Rate Generator begins counting and on each rollover, the state of the SCL pin changes (high-to-low/low-to-high) and data is shifted into the SSPSR. After the falling edge of the eighth clock, the receive enable flag is automatically cleared, the contents of the SSPSR are loaded into the SSPBUF, the BF flag bit is set, the SSPIF flag bit is set and the Baud Rate Generator is suspended from counting, holding SCL low. The MSSP is now in Idle state, awaiting the next command. When the buffer is read by the CPU, the BF flag bit is automatically cleared. The user can then send an Acknowledge bit at the end of reception by setting the Acknowledge Sequence Enable bit, ACKEN (SSPCON2<4>).

17.4.11.1 BF Status Flag

In receive operation, the BF bit is set when an address or data byte is loaded into SSPBUF from SSPSR. It is cleared when the SSPBUF register is read.

17.4.11.2 SSPOV Status Flag

In receive operation, the SSPOV bit is set when 8 bits are received into the SSPSR and the BF flag bit is already set from a previous reception.

17.4.11.3 WCOL Status Flag

If the user writes the SSPBUF when a receive is already in progress (i.e., SSPSR is still shifting in a data byte), the WCOL bit is set and the contents of the buffer are unchanged (the write doesn't occur).

FIGURE 17-21: I²C MASTER MODE WAVEFORM (TRANSMISSION, 7 OR 10-BIT ADDRESS)

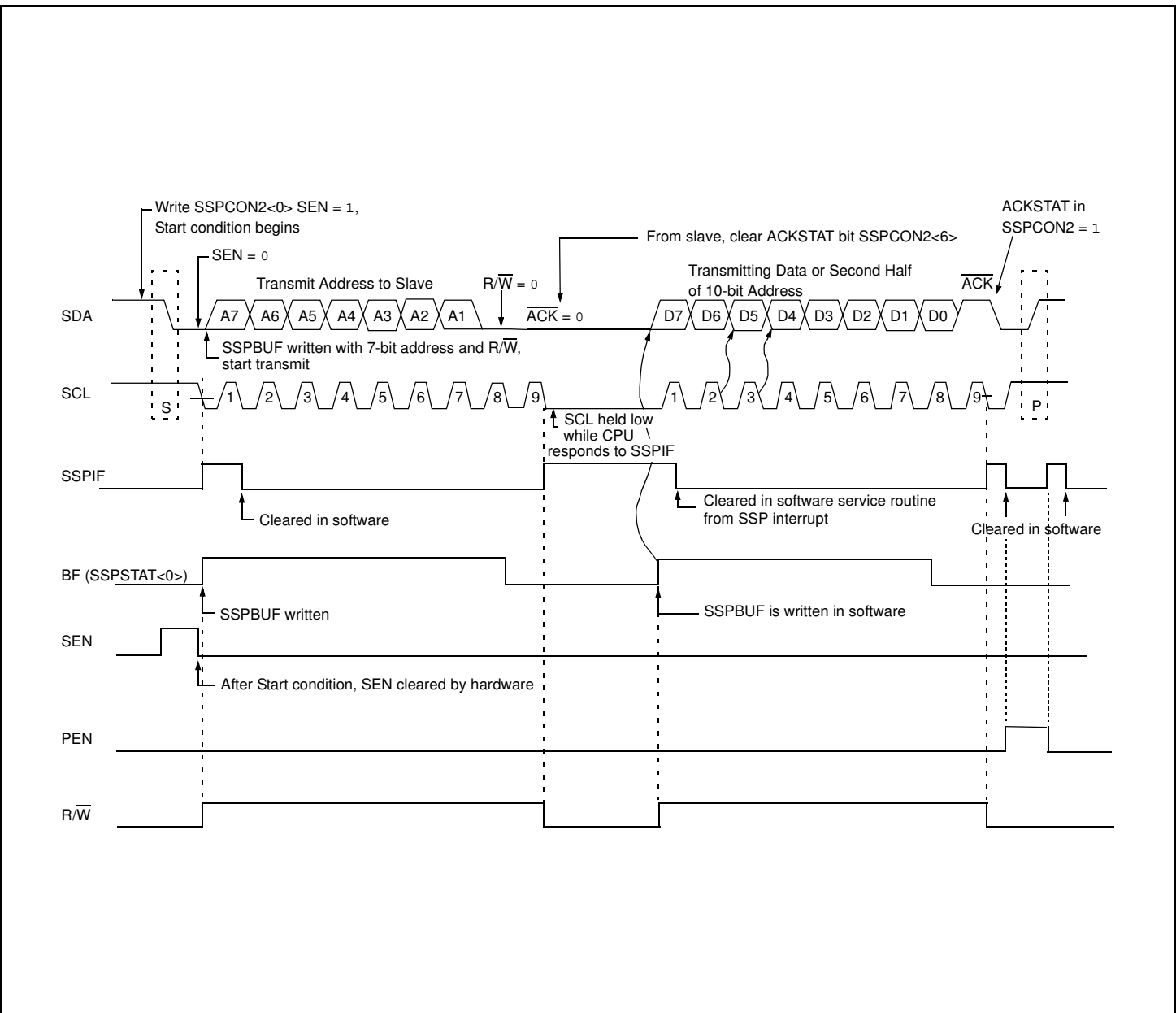
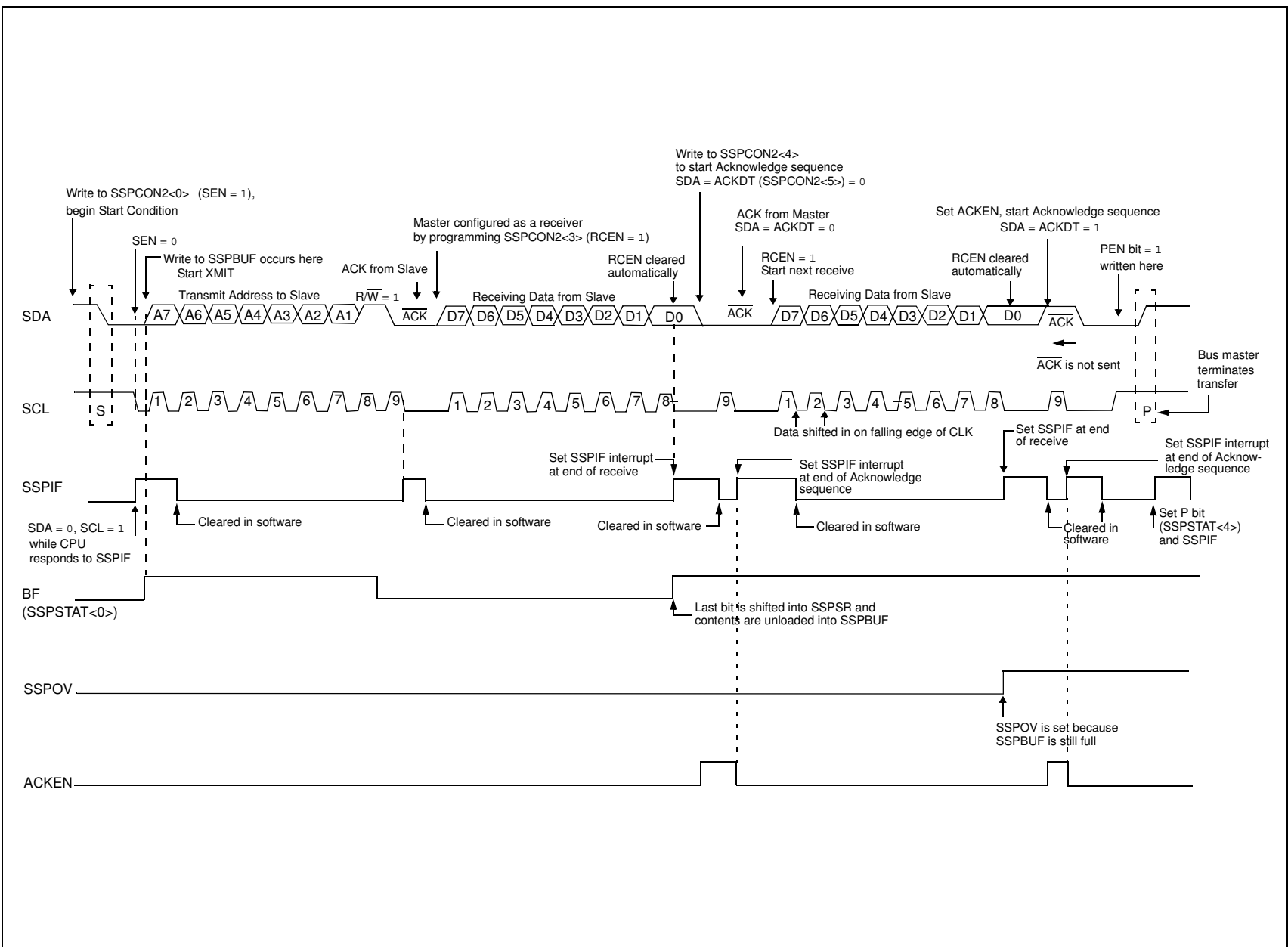

FIGURE 17-22: I²C MASTER MODE WAVEFORM (RECEPTION, 7-BIT ADDRESS)



PIC18F6520/8520/6620/8620/6720/8720

17.4.12 ACKNOWLEDGE SEQUENCE TIMING

An Acknowledge sequence is enabled by setting the Acknowledge Sequence Enable bit, ACKEN (SSPCON2<4>). When this bit is set, the SCL pin is pulled low and the contents of the Acknowledge data bit are presented on the SDA pin. If the user wishes to generate an Acknowledge, then the ACKDT bit should be cleared. If not, the user should set the ACKDT bit before starting an Acknowledge sequence. The Baud Rate Generator then counts for one rollover period (TBRG) and the SCL pin is deasserted (pulled high). When the SCL pin is sampled high (clock arbitration), the Baud Rate Generator counts for TBRG. The SCL pin is then pulled low. Following this, the ACKEN bit is automatically cleared, the Baud Rate Generator is turned off and the MSSP module then goes into Idle mode (Figure 17-23).

17.4.12.1 WCOL Status Flag

If the user writes the SSPBUF when an Acknowledge sequence is in progress, then WCOL is set and the contents of the buffer are unchanged (the write doesn't occur).

17.4.13 STOP CONDITION TIMING

A Stop bit is asserted on the SDA pin at the end of a receive/transmit by setting the Stop Sequence Enable bit, PEN (SSPCON2<2>). At the end of a receive/transmit, the SCL line is held low after the falling edge of the ninth clock. When the PEN bit is set, the master will assert the SDA line low. When the SDA line is sampled low, the Baud Rate Generator is reloaded and counts down to '0'. When the Baud Rate Generator times out, the SCL pin will be brought high and one TBRG (Baud Rate Generator rollover count) later, the SDA pin will be deasserted. When the SDA pin is sampled high while SCL is high, the P bit (SSPSTAT<4>) is set. A TBRG later, the PEN bit is cleared and the SSPIF bit is set (Figure 17-24).

17.4.13.1 WCOL Status Flag

If the user writes the SSPBUF when a Stop sequence is in progress, then the WCOL bit is set and the contents of the buffer are unchanged (the write doesn't occur).

FIGURE 17-23: ACKNOWLEDGE SEQUENCE WAVEFORM

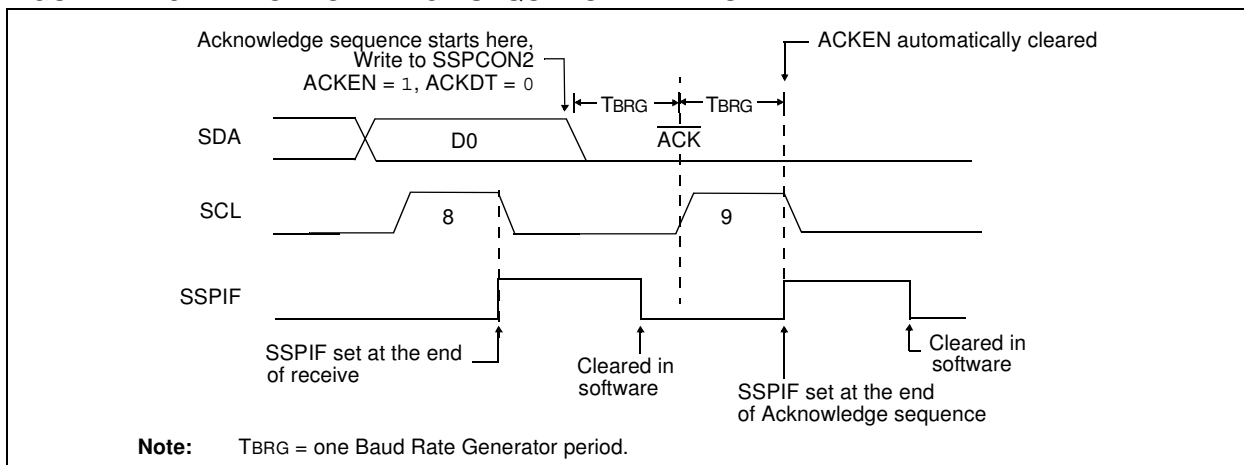
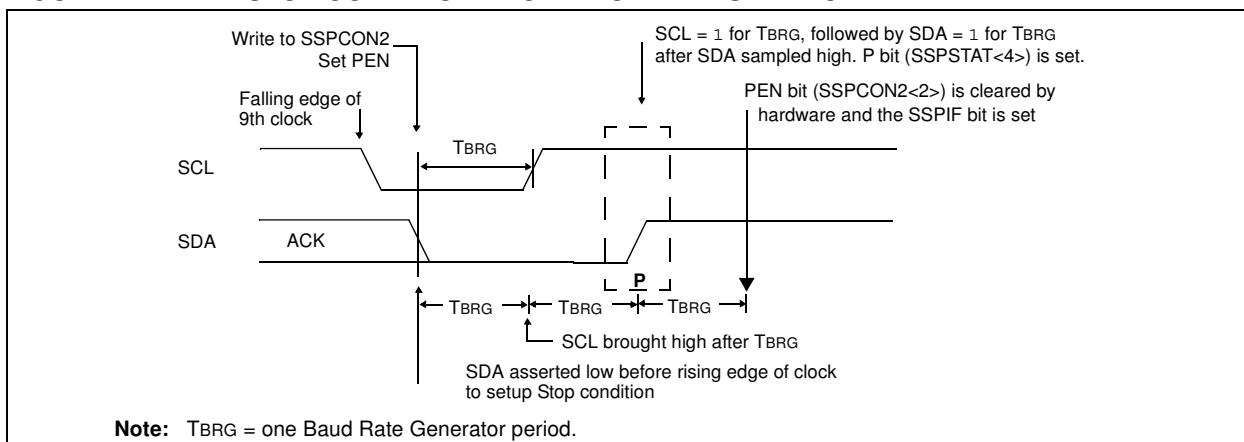

FIGURE 17-24: STOP CONDITION RECEIVE OR TRANSMIT MODE



PIC18F6520/8520/6620/8620/6720/8720

17.4.14 SLEEP OPERATION

While in Sleep mode, the I²C module can receive addresses or data and when an address match or complete byte transfer occurs, wake the processor from Sleep (if the MSSP interrupt is enabled).

17.4.15 EFFECT OF A RESET

A Reset disables the MSSP module and terminates the current transfer.

17.4.16 MULTI-MASTER MODE

In Multi-Master mode, the interrupt generation on the detection of the Start and Stop conditions allows the determination of when the bus is free. The Stop (P) and Start (S) bits are cleared from a Reset or when the MSSP module is disabled. Control of the I²C bus may be taken when the P bit (SSPSTAT<4>) is set, or the bus is idle with both the S and P bits clear. When the bus is busy, enabling the SSP interrupt will generate the interrupt when the Stop condition occurs.

In multi-master operation, the SDA line must be monitored for arbitration, to see if the signal level is the expected output level. This check is performed in hardware, with the result placed in the BCLIF bit.

The states where arbitration can be lost are:

- Address Transfer
- Data Transfer
- A Start Condition
- A Repeated Start Condition
- An Acknowledge Condition

17.4.17 MULTI-MASTER COMMUNICATION, BUS COLLISION AND BUS ARBITRATION

Multi-Master mode support is achieved by bus arbitration. When the master outputs address/data bits onto the SDA pin, arbitration takes place when the master outputs a '1' on SDA, by letting SDA float high and another master asserts a '0'. When the SCL pin floats high, data should be stable. If the expected data on SDA is a '1' and the data sampled on the SDA pin = 0, then a bus collision has taken place. The master will set the Bus Collision Interrupt Flag, BCLIF and reset the I²C port to its Idle state (Figure 17-25).

If a transmit was in progress when the bus collision occurred, the transmission is halted, the BF flag is cleared, the SDA and SCL lines are deasserted and the SSPBUF can be written to. When the user services the bus collision Interrupt Service Routine and if the I²C bus is free, the user can resume communication by asserting a Start condition.

If a Start, Repeated Start, Stop, or Acknowledge condition was in progress when the bus collision occurred, the condition is aborted, the SDA and SCL lines are deasserted and the respective control bits in the SSPCON2 register are cleared. When the user services the bus collision Interrupt Service Routine and if the I²C bus is free, the user can resume communication by asserting a Start condition.

The master will continue to monitor the SDA and SCL pins. If a Stop condition occurs, the SSPIF bit will be set.

A write to the SSPBUF will start the transmission of data at the first data bit, regardless of where the transmitter left off when the bus collision occurred.

In Multi-Master mode, the interrupt generation on the detection of Start and Stop conditions allows the determination of when the bus is free. Control of the I²C bus can be taken when the P bit is set in the SSPSTAT register, or the bus is Idle and the S and P bits are cleared.

FIGURE 17-25: BUS COLLISION TIMING FOR TRANSMIT AND ACKNOWLEDGE

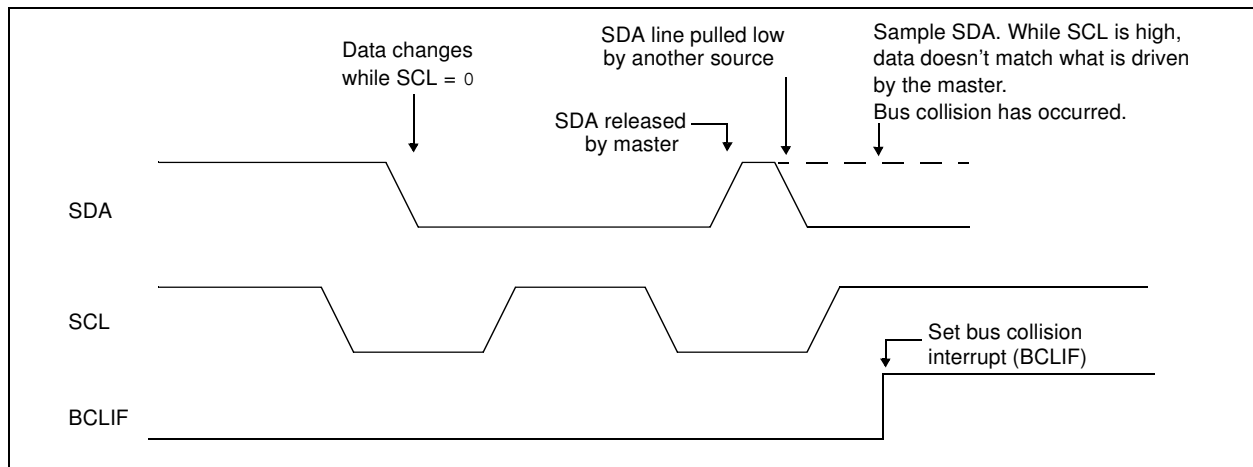

PIC18F6520/8520/6620/8620/6720/8720

17.4.17.1 Bus Collision During a Start Condition

During a Start condition, a bus collision occurs if:

- SDA or SCL are sampled low at the beginning of the Start condition (Figure 17-26).
- SCL is sampled low before SDA is asserted low (Figure 17-27).

During a Start condition, both the SDA and the SCL pins are monitored.

If the SDA pin is already low, or the SCL pin is already low, then all of the following occur:

- the Start condition is aborted,
- the BCLIF flag is set and
- the MSSP module is reset to its Idle state (Figure 17-26).

The Start condition begins with the SDA and SCL pins deasserted. When the SDA pin is sampled high, the Baud Rate Generator is loaded from SSPADD<6:0> and counts down to '0'. If the SCL pin is sampled low while SDA is high, a bus collision occurs, because it is assumed that another master is attempting to drive a data '1' during the Start condition.

If the SDA pin is sampled low during this count, the BRG is reset and the SDA line is asserted early (Figure 17-28). If, however, a '1' is sampled on the SDA pin, the SDA pin is asserted low at the end of the BRG count. The Baud Rate Generator is then reloaded and counts down to '0' and during this time, if the SCL pin is sampled as '0', a bus collision does not occur. At the end of the BRG count, the SCL pin is asserted low.

Note: The reason that bus collision is not a factor during a Start condition is that no two bus masters can assert a Start condition at the exact same time. Therefore, one master will always assert SDA before the other. This condition does not cause a bus collision because the two masters must be allowed to arbitrate the first address following the Start condition. If the address is the same, arbitration must be allowed to continue into the data portion, Repeated Start or Stop conditions.

FIGURE 17-26: BUS COLLISION DURING START CONDITION (SDA ONLY)

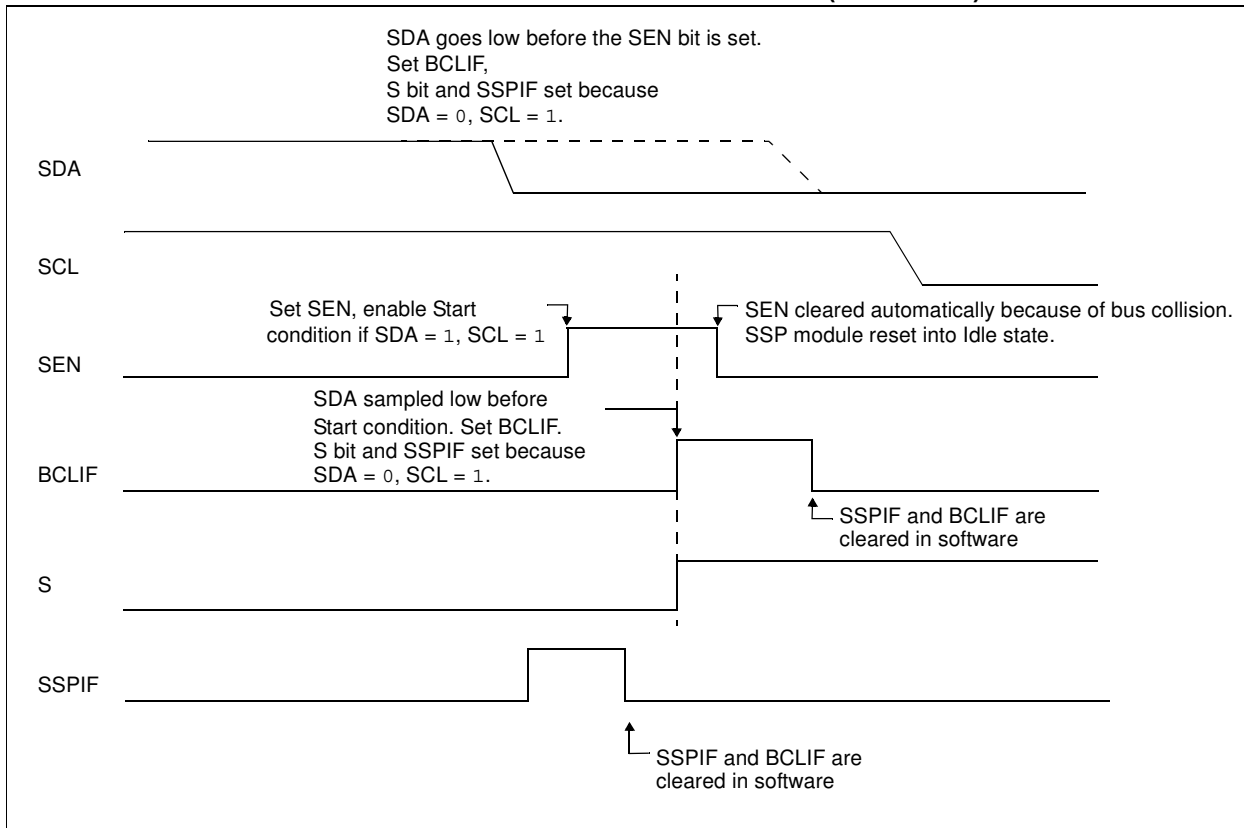

PIC18F6520/8520/6620/8620/6720/8720

FIGURE 17-27: BUS COLLISION DURING START CONDITION (SCL = 0)

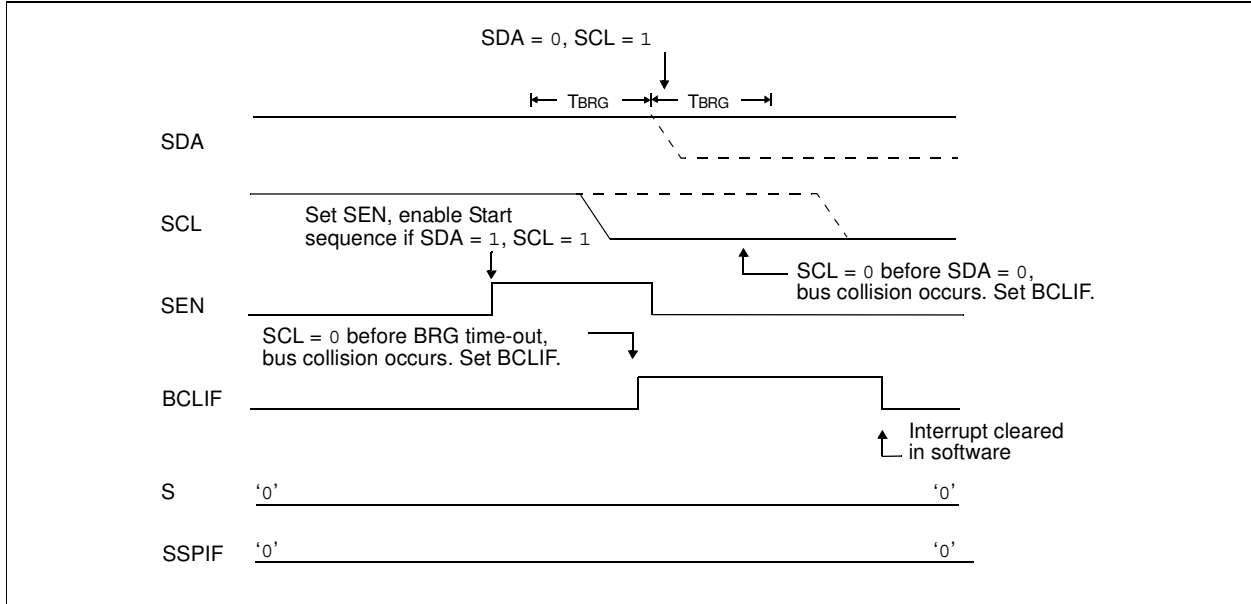
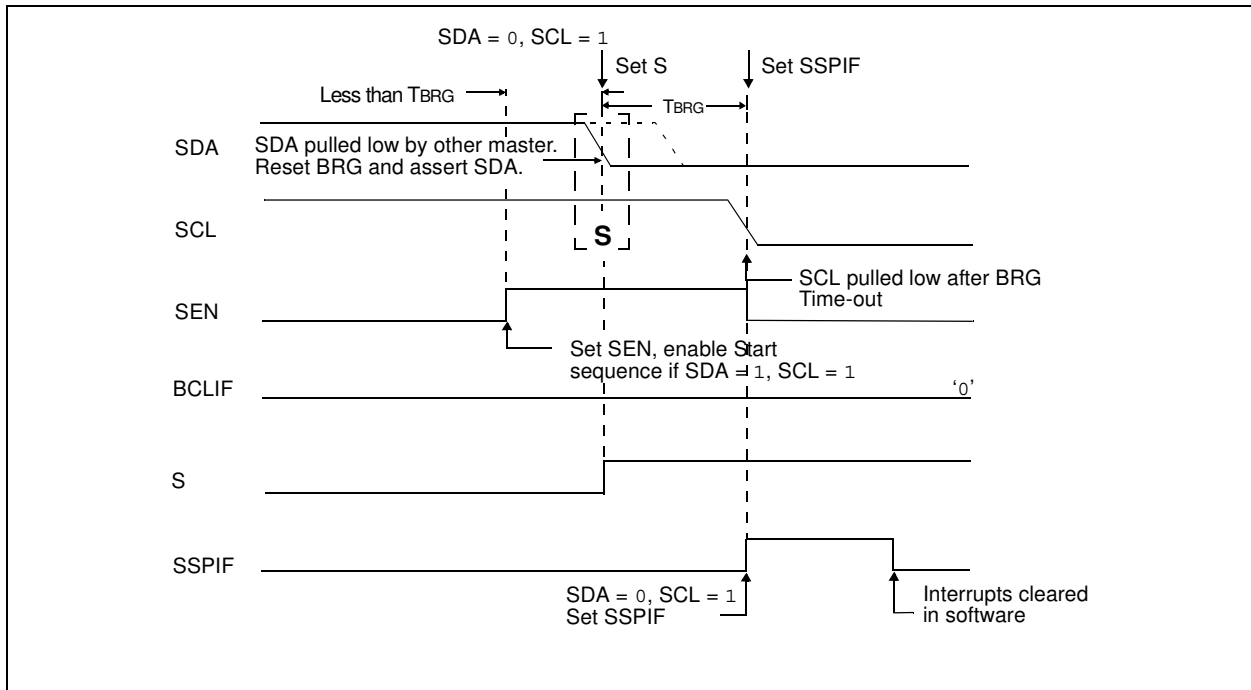

FIGURE 17-28: BRG RESET DUE TO SDA ARBITRATION DURING START CONDITION



PIC18F6520/8520/6620/8620/6720/8720

17.4.17.2 Bus Collision During a Repeated Start Condition

During a Repeated Start condition, a bus collision occurs if:

- A low level is sampled on SDA when SCL goes from low level to high level.
- SCL goes low before SDA is asserted low, indicating that another master is attempting to transmit a data '1'.

When the user deasserts SDA and the pin is allowed to float high, the BRG is loaded with SSPADD<6:0> and counts down to '0'. The SCL pin is then deasserted and when sampled high, the SDA pin is sampled.

If SDA is low, a bus collision has occurred (i.e., another master is attempting to transmit a data '0', Figure 17-29). If SDA is sampled high, the BRG is reloaded and begins counting. If SDA goes from high-to-low before the BRG times out, no bus collision occurs because no two masters can assert SDA at exactly the same time.

If SCL goes from high-to-low before the BRG times out and SDA has not already been asserted, a bus collision occurs. In this case, another master is attempting to transmit a data '1' during the Repeated Start condition, Figure 17-30.

If, at the end of the BRG time-out, both SCL and SDA are still high, the SDA pin is driven low and the BRG is reloaded and begins counting. At the end of the count, regardless of the status of the SCL pin, the SCL pin is driven low and the Repeated Start condition is complete.

FIGURE 17-29: BUS COLLISION DURING A REPEATED START CONDITION (CASE 1)

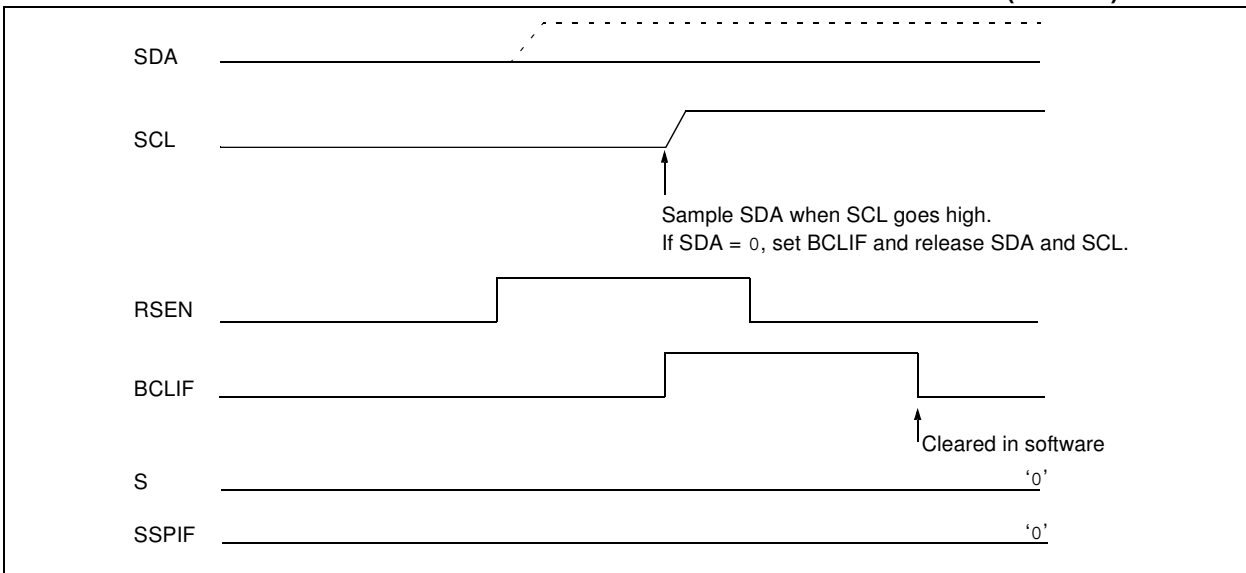
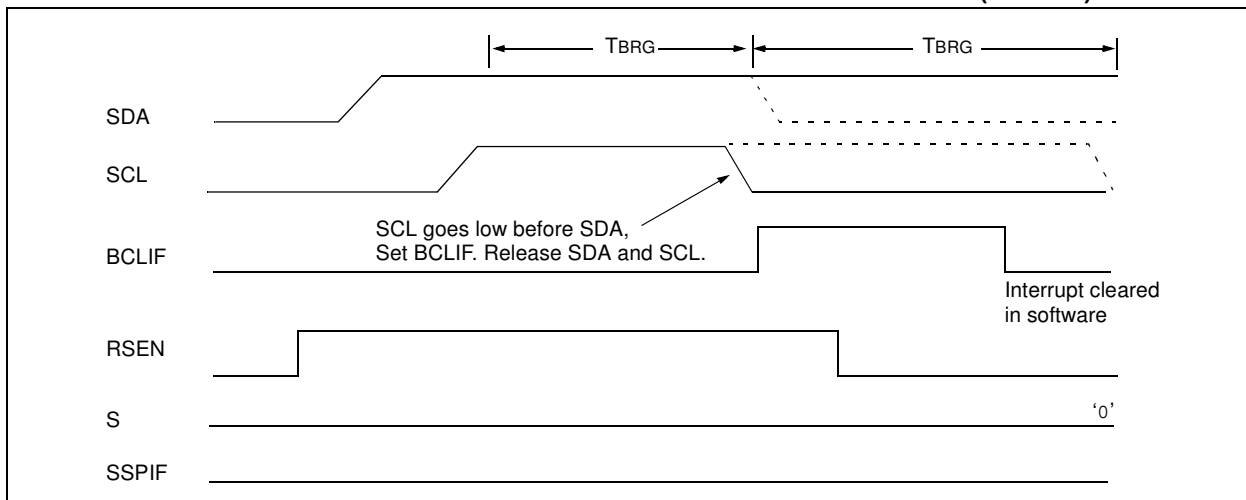

FIGURE 17-30: BUS COLLISION DURING REPEATED START CONDITION (CASE 2)



PIC18F6520/8520/6620/8620/6720/8720

17.4.17.3 Bus Collision During a Stop Condition

Bus collision occurs during a Stop condition if:

- After the SDA pin has been deasserted and allowed to float high, SDA is sampled low after the BRG has timed out.
- After the SCL pin is deasserted, SCL is sampled low before SDA goes high.

The Stop condition begins with SDA asserted low. When SDA is sampled low, the SCL pin is allowed to float. When the pin is sampled high (clock arbitration), the Baud Rate Generator is loaded with SSPADD<6:0> and counts down to '0'. After the BRG times out, SDA is sampled. If SDA is sampled low, a bus collision has occurred. This is due to another master attempting to drive a data '0' (Figure 17-31). If the SCL pin is sampled low before SDA is allowed to float high, a bus collision occurs. This is another case of another master attempting to drive a data '0' (Figure 17-32).

FIGURE 17-31: BUS COLLISION DURING A STOP CONDITION (CASE 1)

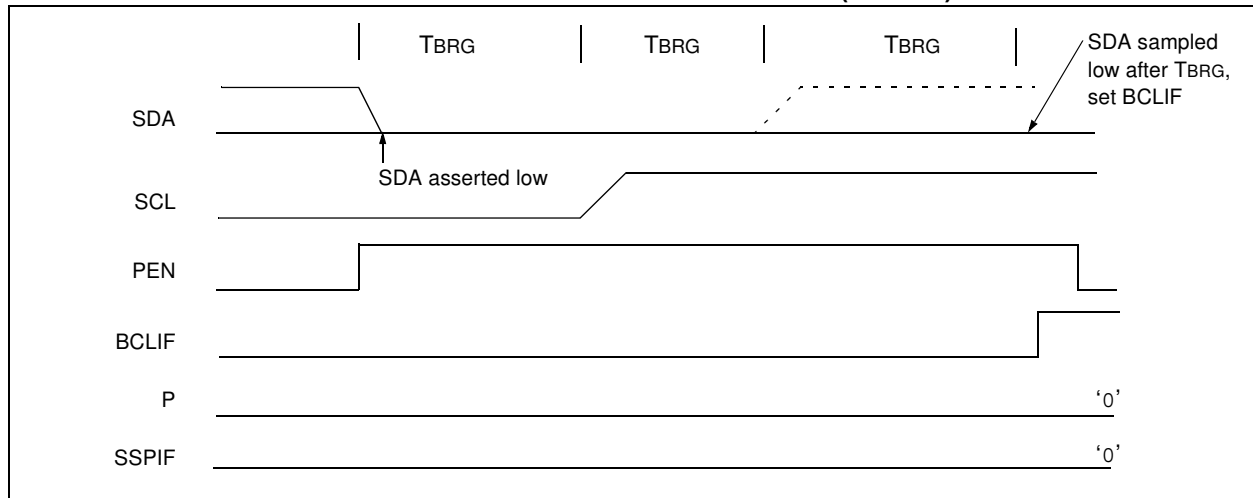
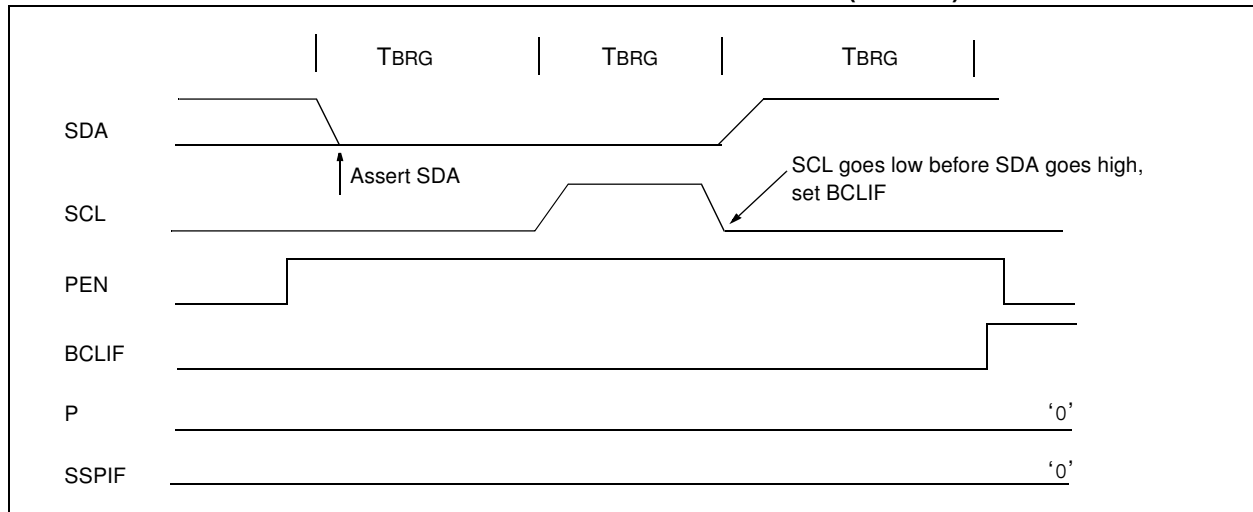

FIGURE 17-32: BUS COLLISION DURING A STOP CONDITION (CASE 2)



PIC18F6520/8520/6620/8620/6720/8720

NOTES:

18.0 ADDRESSABLE UNIVERSAL SYNCHRONOUS ASYNCHRONOUS RECEIVER TRANSMITTER (USART)

The Universal Synchronous Asynchronous Receiver Transmitter (USART) module (also known as a Serial Communications Interface or SCI) is one of the two types of serial I/O modules available on PIC18FXX20 devices. Each device has two USARTs, which can be configured independently of each other. Each can be configured as a full-duplex asynchronous system that can communicate with peripheral devices, such as CRT terminals and personal computers, or as a half-duplex synchronous system that can communicate with peripheral devices, such as A/D or D/A integrated circuits, serial EEPROMs, etc.

The USART can be configured in the following modes:

- Asynchronous (full-duplex)
- Synchronous – Master (half-duplex)
- Synchronous – Slave (half-duplex)

The pins of USART1 and USART2 are multiplexed with the functions of PORTC (RC6/TX1/CK1 and RC7/RX1/DT1) and PORTG (RG1/TX2/CK2 and RG2/RX2/DT2), respectively. In order to configure these pins as a USART:

- For USART1:
 - bit SPEN (RCSTA1<7>) must be set (= 1)
 - bit TRISC<7> must be set (= 1)
 - bit TRISC<6> must be cleared (= 0) for Asynchronous and Synchronous Master modes
 - bit TRISC<6> must be set (= 1) for Synchronous Slave mode
- For USART2:
 - bit SPEN (RCSTA2<7>) must be set (= 1)
 - bit TRISG<2> must be set (= 1)
 - bit TRISG<1> must be cleared (= 0) for Asynchronous and Synchronous Master modes
 - bit TRISC<6> must be set (= 1) for Synchronous Slave mode

Register 18-1 shows the layout of the Transmit Status and Control registers (TXSTAx) and Register 18-2 shows the layout of the Receive Status and Control registers (RCSTAx). USART1 and USART2 each have their own independent and distinct pairs of transmit and receive control registers, which are identical to each other apart from their names. Similarly, each USART has its own distinct set of transmit, receive and baud rate registers.

Note: Throughout this section, references to register and bit names that may be associated with a specific USART module are referred to generically by the use of 'x' in place of the specific module number. Thus, "RCSTAx" might refer to the receive status register for either USART1 or USART2.

PIC18F6520/8520/6620/8620/6720/8720

REGISTER 18-1: TXSTAx: TRANSMIT STATUS AND CONTROL REGISTER

R/W-0	R/W-0	R/W-0	R/W-0	U-0	R/W-0	R-1	R/W-0
CSRC	TX9	TXEN	SYNC	—	BRGH	TRMT	TX9D

bit 7 bit 0

bit 7 **CSRC:** Clock Source Select bit

Asynchronous mode:

Don't care.

Synchronous mode:

1 = Master mode (clock generated internally from BRG)

0 = Slave mode (clock from external source)

bit 6 **TX9:** 9-bit Transmit Enable bit

1 = Selects 9-bit transmission

0 = Selects 8-bit transmission

bit 5 **TXEN:** Transmit Enable bit

1 = Transmit enabled

0 = Transmit disabled

Note: SREN/CREN overrides TXEN in Sync mode.

bit 4 **SYNC:** USART Mode Select bit

1 = Synchronous mode

0 = Asynchronous mode

bit 3 **Unimplemented:** Read as '0'

bit 2 **BRGH:** High Baud Rate Select bit

Asynchronous mode:

1 = High speed

0 = Low speed

Synchronous mode:

Unused in this mode.

bit 1 **TRMT:** Transmit Shift Register Status bit

1 = TSR empty

0 = TSR full

bit 0 **TX9D:** 9th bit of Transmit Data

Can be address/data bit or a parity bit.

Legend:

R = Readable bit

W = Writable bit

U = Unimplemented bit, read as '0'

- n = Value at POR

'1' = Bit is set

'0' = Bit is cleared

x = Bit is unknown

PIC18F6520/8520/6620/8620/6720/8720

REGISTER 18-2: RCSTAx: RECEIVE STATUS AND CONTROL REGISTER

R/W-0	R/W-0	R/W-0	R/W-0	R/W-0	R-0	R-0	R-x
SPEN	RX9	SREN	CREN	ADDEN	FERR	OERR	RX9D
bit 7							bit 0

- bit 7 **SPEN:** Serial Port Enable bit
 1 = Serial port enabled (configures RX/DT and TX/CK pins as serial port pins)
 0 = Serial port disabled
- bit 6 **RX9:** 9-bit Receive Enable bit
 1 = Selects 9-bit reception
 0 = Selects 8-bit reception
- bit 5 **SREN:** Single Receive Enable bit
Asynchronous mode:
 Don't care.
Synchronous mode – Master:
 1 = Enables single receive
 0 = Disables single receive
 This bit is cleared after reception is complete.
Synchronous mode – Slave:
 Don't care.
- bit 4 **CREN:** Continuous Receive Enable bit
Asynchronous mode:
 1 = Enables receiver
 0 = Disables receiver
Synchronous mode:
 1 = Enables continuous receive until enable bit CREN is cleared (CREN overrides SREN)
 0 = Disables continuous receive
- bit 3 **ADDEN:** Address Detect Enable bit
Asynchronous mode 9-bit (RX9 = 1):
 1 = Enables address detection, enables interrupt and load of the receive buffer when RSR<8> is set
 0 = Disables address detection, all bytes are received and ninth bit can be used as parity bit
- bit 2 **FERR:** Framing Error bit
 1 = Framing error (can be updated by reading RCREG register and receive next valid byte)
 0 = No framing error
- bit 1 **OERR:** Overrun Error bit
 1 = Overrun error (can be cleared by clearing bit CREN)
 0 = No overrun error
- bit 0 **RX9D:** 9th bit of Received Data
 This can be address/data bit or a parity bit and must be calculated by user firmware.

Legend:

R = Readable bit	W = Writable bit	U = Unimplemented bit, read as '0'
- n = Value at POR	'1' = Bit is set	'0' = Bit is cleared x = Bit is unknown

PIC18F6520/8520/6620/8620/6720/8720

18.1 USART Baud Rate Generator (BRG)

The BRG supports both the Asynchronous and Synchronous modes of the USARTs. It is a dedicated 8-bit Baud Rate Generator. The SPBRG register controls the period of a free running 8-bit timer. In Asynchronous mode, bit BRGH (TXSTAx<2>) also controls the baud rate. In Synchronous mode, bit BRGH is ignored. Table 18-1 shows the formula for computation of the baud rate for different USART modes, which only apply in Master mode (internal clock).

Given the desired baud rate and FOSC, the nearest integer value for the SPBRGx register can be calculated using the formula in Table 18-1. From this, the error in baud rate can be determined.

Example 18-1 shows the calculation of the baud rate error for the following conditions:

- FOSC = 16 MHz
- Desired Baud Rate = 9600
- BRGH = 0
- SYNC = 0

It may be advantageous to use the high baud rate (BRGH = 1) even for slower baud clocks. This is because the equation in Example 18-1 can reduce the baud rate error in some cases.

Writing a new value to the SPBRGx register causes the BRG timer to be reset (or cleared). This ensures the BRG does not wait for a timer overflow before outputting the new baud rate.

18.1.1 SAMPLING

The data on the RXx pin (either RC7/RX1/DT1 or RG2/RX2/DT2) is sampled three times by a majority detect circuit to determine if a high or a low level is present at the pin.

EXAMPLE 18-1: CALCULATING BAUD RATE ERROR

Desired Baud Rate	=	$FOSC / (64 (X + 1))$
Solving for X:		
X	=	$((FOSC / \text{Desired Baud Rate}) / 64) - 1$
X	=	$((16000000 / 9600) / 64) - 1$
X	=	$[25.042] = 25$
Calculated Baud Rate	=	$16000000 / (64 (25 + 1))$
	=	9615
Error	=	$\frac{(\text{Calculated Baud Rate} - \text{Desired Baud Rate})}{\text{Desired Baud Rate}}$
	=	$(9615 - 9600) / 9600$
	=	0.16%

TABLE 18-1: BAUD RATE FORMULA

SYNC	BRGH = 0 (Low Speed)	BRGH = 1 (High Speed)
0	(Asynchronous) Baud Rate = $FOSC / (64(X + 1))$	Baud Rate = $FOSC / (16(X + 1))$
1	(Synchronous) Baud Rate = $FOSC / (4(X + 1))$	N/A

Legend: X = value in SPBRGx (0 to 255)

TABLE 18-2: REGISTERS ASSOCIATED WITH BAUD RATE GENERATOR

Name	Bit 7	Bit 6	Bit 5	Bit 4	Bit 3	Bit 2	Bit 1	Bit 0	Value on POR, BOR	Value on all other Resets
TXSTAx	CSRC	TX9	TXEN	SYNC	—	BRGH	TRMT	TX9D	0000 -010	0000 -010
RCSTAx	SPEN	RX9	SREN	CREN	ADDEN	FERR	OERR	RX9D	0000 000x	0000 000x
SPBRGx	Baud Rate Generator Register								0000 0000	0000 0000

Legend: x = unknown, — = unimplemented, read as '0'. Shaded cells are not used by the BRG.

Note 1: Register names generically refer to both of the identically named registers for the two USART modules, where 'x' indicates the particular module. Bit names and Reset values are identical between modules.

PIC18F6520/8520/6620/8620/6720/8720

TABLE 18-3: BAUD RATES FOR SYNCHRONOUS MODE

BAUD RATE (Kbps)	Fosc = 40 MHz			33 MHz			25 MHz			20 MHz		
	KBAUD	% ERROR	SPBRG value (decimal)	KBAUD	% ERROR	SPBRG value (decimal)	KBAUD	% ERROR	SPBRG value (decimal)	KBAUD	% ERROR	SPBRG value (decimal)
0.3	NA	-	-	NA	-	-	NA	-	-	NA	-	-
1.2	NA	-	-	NA	-	-	NA	-	-	NA	-	-
2.4	NA	-	-	NA	-	-	NA	-	-	NA	-	-
9.6	NA	-	-	NA	-	-	NA	-	-	NA	-	-
19.2	NA	-	-	NA	-	-	NA	-	-	NA	-	-
76.8	76.92	+0.16	129	77.10	+0.39	106	77.16	+0.47	80	76.92	+0.16	64
96	96.15	+0.16	103	95.93	-0.07	85	96.15	+0.16	64	96.15	+0.16	51
300	303.03	+1.01	32	294.64	-1.79	27	297.62	-0.79	20	294.12	-1.96	16
500	500	0	19	485.30	-2.94	16	480.77	-3.85	12	500	0	9
HIGH	10000	-	0	8250	-	0	6250	-	0	5000	-	0
LOW	39.06	-	255	32.23	-	255	24.41	-	255	19.53	-	255

BAUD RATE (Kbps)	Fosc = 16 MHz			10 MHz			7.15909 MHz			5.0688 MHz		
	KBAUD	% ERROR	SPBRG value (decimal)	KBAUD	% ERROR	SPBRG value (decimal)	KBAUD	% ERROR	SPBRG value (decimal)	KBAUD	% ERROR	SPBRG value (decimal)
0.3	NA	-	-	NA	-	-	NA	-	-	NA	-	-
1.2	NA	-	-	NA	-	-	NA	-	-	NA	-	-
2.4	NA	-	-	NA	-	-	NA	-	-	NA	-	-
9.6	NA	-	-	NA	-	-	9.62	+0.23	185	9.60	0	131
19.2	19.23	+0.16	207	19.23	+0.16	129	19.24	+0.23	92	19.20	0	65
76.8	76.92	+0.16	51	75.76	-1.36	32	77.82	+1.32	22	74.54	-2.94	16
96	95.24	-0.79	41	96.15	+0.16	25	94.20	-1.88	18	97.48	+1.54	12
300	307.70	+2.56	12	312.50	+4.17	7	298.35	-0.57	5	316.80	+5.60	3
500	500	0	7	500	0	4	447.44	-10.51	3	422.40	-15.52	2
HIGH	4000	-	0	2500	-	0	1789.80	-	0	1267.20	-	0
LOW	15.63	-	255	9.77	-	255	6.99	-	255	4.95	-	255

BAUD RATE (Kbps)	Fosc = 4 MHz			3.579545 MHz			1 MHz			32.768 kHz		
	KBAUD	% ERROR	SPBRG value (decimal)	KBAUD	% ERROR	SPBRG value (decimal)	KBAUD	% ERROR	SPBRG value (decimal)	KBAUD	% ERROR	SPBRG value (decimal)
0.3	NA	-	-	NA	-	-	NA	-	-	0.30	+1.14	26
1.2	NA	-	-	NA	-	-	1.20	+0.16	207	1.17	-2.48	6
2.4	NA	-	-	NA	-	-	2.40	+0.16	103	2.73	+13.78	2
9.6	9.62	+0.16	103	9.62	+0.23	92	9.62	+0.16	25	8.20	-14.67	0
19.2	19.23	+0.16	51	19.04	-0.83	46	19.23	+0.16	12	NA	-	-
76.8	76.92	+0.16	12	74.57	-2.90	11	83.33	+8.51	2	NA	-	-
96	1000	+4.17	9	99.43	+3.57	8	83.33	-13.19	2	NA	-	-
300	333.33	+11.11	2	298.30	-0.57	2	250	-16.67	0	NA	-	-
500	500	0	1	447.44	-10.51	1	NA	-	-	NA	-	-
HIGH	1000	-	0	894.89	-	0	250	-	0	8.20	-	0
LOW	3.91	-	255	3.50	-	255	0.98	-	255	0.03	-	255

PIC18F6520/8520/6620/8620/6720/8720

TABLE 18-4: BAUD RATES FOR ASYNCHRONOUS MODE (BRGH = 0)

BAUD RATE (Kbps)	Fosc = 40 MHz			33 MHz			25 MHz			20 MHz		
	KBAUD	% ERROR	SPBRG value (decimal)	KBAUD	% ERROR	SPBRG value (decimal)	KBAUD	% ERROR	SPBRG value (decimal)	KBAUD	% ERROR	SPBRG value (decimal)
0.3	NA	-	-	NA	-	-	NA	-	-	NA	-	-
1.2	NA	-	-	NA	-	-	NA	-	-	NA	-	-
2.4	NA	-	-	2.40	-0.07	214	2.40	-0.15	162	2.40	+0.16	129
9.6	9.62	+0.16	64	9.55	-0.54	53	9.53	-0.76	40	9.47	-1.36	32
19.2	18.94	-1.36	32	19.10	-0.54	26	19.53	+1.73	19	19.53	+1.73	15
76.8	78.13	+1.73	7	73.66	-4.09	6	78.13	+1.73	4	78.13	+1.73	3
96	89.29	-6.99	6	103.13	+7.42	4	97.66	+1.73	3	104.17	+8.51	2
300	312.50	+4.17	1	257.81	-14.06	1	NA	-	-	312.50	+4.17	0
500	625	+25.00	0	NA	-	-	NA	-	-	NA	-	-
HIGH	625	-	0	515.63	-	0	390.63	-	0	312.50	-	0
LOW	2.44	-	255	2.01	-	255	1.53	-	255	1.22	-	255

BAUD RATE (Kbps)	Fosc = 16 MHz			10 MHz			7.15909 MHz			5.0688 MHz		
	KBAUD	% ERROR	SPBRG value (decimal)	KBAUD	% ERROR	SPBRG value (decimal)	KBAUD	% ERROR	SPBRG value (decimal)	KBAUD	% ERROR	SPBRG value (decimal)
0.3	NA	-	-	NA	-	-	NA	-	-	NA	-	-
1.2	1.20	+0.16	207	1.20	+0.16	129	1.20	+0.23	92	1.20	0	65
2.4	2.40	+0.16	103	2.40	+0.16	64	2.38	-0.83	46	2.40	0	32
9.6	9.62	+0.16	25	9.77	+1.73	15	9.32	-2.90	11	9.90	+3.13	7
19.2	19.23	+0.16	12	19.53	+1.73	7	18.64	-2.90	5	19.80	+3.13	3
76.8	83.33	+8.51	2	78.13	+1.73	1	111.86	+45.65	0	79.20	+3.13	0
96	83.33	-13.19	2	78.13	-18.62	1	NA	-	-	NA	-	-
300	250	-16.67	0	156.25	-47.92	0	NA	-	-	NA	-	-
500	NA	-	-	NA	-	-	NA	-	-	NA	-	-
HIGH	250	-	0	156.25	-	0	111.86	-	0	79.20	-	0
LOW	0.98	-	255	0.61	-	255	0.44	-	255	0.31	-	255

BAUD RATE (Kbps)	Fosc = 4 MHz			3.579545 MHz			1 MHz			32.768 kHz		
	KBAUD	% ERROR	SPBRG value (decimal)	KBAUD	% ERROR	SPBRG value (decimal)	KBAUD	% ERROR	SPBRG value (decimal)	KBAUD	% ERROR	SPBRG value (decimal)
0.3	0.30	-0.16	207	0.30	+0.23	185	0.30	+0.16	51	0.26	-14.67	1
1.2	1.20	+1.67	51	1.19	-0.83	46	1.20	+0.16	12	NA	-	-
2.4	2.40	+1.67	25	2.43	+1.32	22	2.23	-6.99	6	NA	-	-
9.6	8.93	-6.99	6	9.32	-2.90	5	7.81	-18.62	1	NA	-	-
19.2	20.83	+8.51	2	18.64	-2.90	2	15.63	-18.62	0	NA	-	-
76.8	62.50	-18.62	0	55.93	-27.17	0	NA	-	-	NA	-	-
96	NA	-	-	NA	-	-	NA	-	-	NA	-	-
300	NA	-	-	NA	-	-	NA	-	-	NA	-	-
500	NA	-	-	NA	-	-	NA	-	-	NA	-	-
HIGH	62.50	-	0	55.93	-	0	15.63	-	0	0.51	-	0
LOW	0.24	-	255	0.22	-	255	0.06	-	255	0.002	-	255

PIC18F6520/8520/6620/8620/6720/8720

TABLE 18-5: BAUD RATES FOR ASYNCHRONOUS MODE (BRGH = 1)

BAUD RATE (Kbps)	Fosc = 40 MHz			33 MHz			25 MHz			20 MHz		
	KBAUD	% ERROR	SPBRG value (decimal)	KBAUD	% ERROR	SPBRG value (decimal)	KBAUD	% ERROR	SPBRG value (decimal)	KBAUD	% ERROR	SPBRG value (decimal)
0.3	NA	-	-	NA	-	-	NA	-	-	NA	-	-
1.2	NA	-	-	NA	-	-	NA	-	-	NA	-	-
2.4	NA	-	-	NA	-	-	NA	-	-	NA	-	-
9.6	NA	-	-	9.60	-0.07	214	9.59	-0.15	162	9.62	+0.16	129
19.2	19.23	+0.16	129	19.28	+0.39	106	19.30	+0.47	80	19.23	+0.16	64
76.8	75.76	-1.36	32	76.39	-0.54	26	78.13	+1.73	19	78.13	+1.73	15
96	96.15	+0.16	25	98.21	+2.31	20	97.66	+1.73	15	96.15	+0.16	12
300	312.50	+4.17	7	294.64	-1.79	6	312.50	+4.17	4	312.50	+4.17	3
500	500	0	4	515.63	+3.13	3	520.83	+4.17	2	416.67	-16.67	2
HIGH	2500	-	0	2062.50	-	0	1562.50	-	0	1250	-	0
LOW	9.77	-	255	8.06	-	255	6.10	-	255	4.88	-	255

BAUD RATE (Kbps)	Fosc = 16 MHz			10 MHz			7.15909 MHz			5.0688 MHz		
	KBAUD	% ERROR	SPBRG value (decimal)	KBAUD	% ERROR	SPBRG value (decimal)	KBAUD	% ERROR	SPBRG value (decimal)	KBAUD	% ERROR	SPBRG value (decimal)
0.3	NA	-	-	NA	-	-	NA	-	-	NA	-	-
1.2	NA	-	-	NA	-	-	NA	-	-	NA	-	-
2.4	NA	-	-	NA	-	-	2.41	+0.23	185	2.40	0	131
9.6	9.62	+0.16	103	9.62	+0.16	64	9.52	-0.83	46	9.60	0	32
19.2	19.23	+0.16	51	18.94	-1.36	32	19.45	+1.32	22	18.64	-2.94	16
76.8	76.92	+0.16	12	78.13	+1.73	7	74.57	-2.90	5	79.20	+3.13	3
96	100	+4.17	9	89.29	-6.99	6	89.49	-6.78	4	105.60	+10.00	2
300	333.33	+11.11	2	312.50	+4.17	1	447.44	+49.15	0	316.80	+5.60	0
500	500	0	1	625	+25.00	0	447.44	-10.51	0	NA	-	-
HIGH	1000	-	0	625	-	0	447.44	-	0	316.80	-	0
LOW	3.91	-	255	2.44	-	255	1.75	-	255	1.24	-	255

BAUD RATE (Kbps)	Fosc = 4 MHz			3.579545 MHz			1 MHz			32.768 kHz		
	KBAUD	% ERROR	SPBRG value (decimal)	KBAUD	% ERROR	SPBRG value (decimal)	KBAUD	% ERROR	SPBRG value (decimal)	KBAUD	% ERROR	SPBRG value (decimal)
0.3	NA	-	-	NA	-	-	0.30	+0.16	207	0.29	-2.48	6
1.2	1.20	+0.16	207	1.20	+0.23	185	1.20	+0.16	51	1.02	-14.67	1
2.4	2.40	+0.16	103	2.41	+0.23	92	2.40	+0.16	25	2.05	-14.67	0
9.6	9.62	+0.16	25	9.73	+1.32	22	8.93	-6.99	6	NA	-	-
19.2	19.23	+0.16	12	18.64	-2.90	11	20.83	+8.51	2	NA	-	-
76.8	NA	-	-	74.57	-2.90	2	62.50	-18.62	0	NA	-	-
96	NA	-	-	111.86	+16.52	1	NA	-	-	NA	-	-
300	NA	-	-	223.72	-25.43	0	NA	-	-	NA	-	-
500	NA	-	-	NA	-	-	NA	-	-	NA	-	-
HIGH	250	-	0	55.93	-	0	62.50	-	0	2.05	-	0
LOW	0.98	-	255	0.22	-	255	0.24	-	255	0.008	-	255

PIC18F6520/8520/6620/8620/6720/8720

18.2 USART Asynchronous Mode

In this mode, the USARTs use standard Non-Return-to-Zero (NRZ) format (one Start bit, eight or nine data bits and one Stop bit). The most common data format is 8 bits. An on-chip dedicated 8-bit Baud Rate Generator can be used to derive standard baud rate frequencies from the oscillator. The USART transmits and receives the LSb first. The USART's transmitter and receiver are functionally independent, but use the same data format and baud rate. The Baud Rate Generator produces a clock, either 16 or 64 times the bit shift rate, depending on bit BRGH (TXSTAx<2>). Parity is not supported by the hardware, but can be implemented in software (and stored as the ninth data bit). Asynchronous mode is stopped during Sleep.

Asynchronous mode is selected by clearing bit SYNC (TXSTAx<4>).

The USART Asynchronous module consists of the following important elements:

- Baud Rate Generator
- Sampling Circuit
- Asynchronous Transmitter
- Asynchronous Receiver

18.2.1 USART ASYNCHRONOUS TRANSMITTER

The USART transmitter block diagram is shown in Figure 18-1. The heart of the transmitter is the Transmit (Serial) Shift Register (TSR). The shift register obtains its data from the Read/Write Transmit Buffer register, TXREGx. The TXREGx register is loaded with data in software. The TSR register is not loaded until the Stop bit has been transmitted from the previous load. As soon as the Stop bit is transmitted, the TSR is loaded with new data from the TXREGx register (if available). Once the TXREGx register transfers the data to the TSR register (occurs in one Tcy), the TXREGx register is empty and flag bit, TXx1IF (PIR1<4> for USART1,

PIR3<4> for USART2), is set. This interrupt can be enabled/disabled by setting/clearing enable bit, TXxIE (PIE1<4> for USART1, PIE<4> for USART2). Flag bit TXxIF will be set, regardless of the state of enable bit TXxIE and cannot be cleared in software. It will reset only when new data is loaded into the TXREGx register. While flag bit TXIF indicates the status of the TXREGx register, another bit, TRMT (TXSTAx<1>), shows the status of the TSR register. Status bit TRMT is a read-only bit, which is set when the TSR register is empty. No interrupt logic is tied to this bit, so the user has to poll this bit in order to determine if the TSR register is empty.

Note 1: The TSR register is not mapped in data memory, so it is not available to the user.

2: Flag bit TXIF is set when enable bit TXEN is set.

To set up an Asynchronous Transmission:

1. Initialize the SPBRGx register for the appropriate baud rate. If a high-speed baud rate is desired, set bit BRGH (**Section 18.1 "USART Baud Rate Generator (BRG)"**).
2. Enable the asynchronous serial port by clearing bit SYNC and setting bit SPEN.
3. If interrupts are desired, set enable bit TXxIE in the appropriate PIE register.
4. If 9-bit transmission is desired, set transmit bit TX9. Can be used as address/data bit.
5. Enable the transmission by setting bit TXEN, which will also set bit TXxIF.
6. If 9-bit transmission is selected, the ninth bit should be loaded in bit TX9D.
7. Load data to the TXREGx register (starts transmission).

Note: TXIF is not cleared immediately upon loading data into the transmit buffer TXREG. The flag bit becomes valid in the second instruction cycle following the load instruction.

FIGURE 18-1: USART TRANSMIT BLOCK DIAGRAM

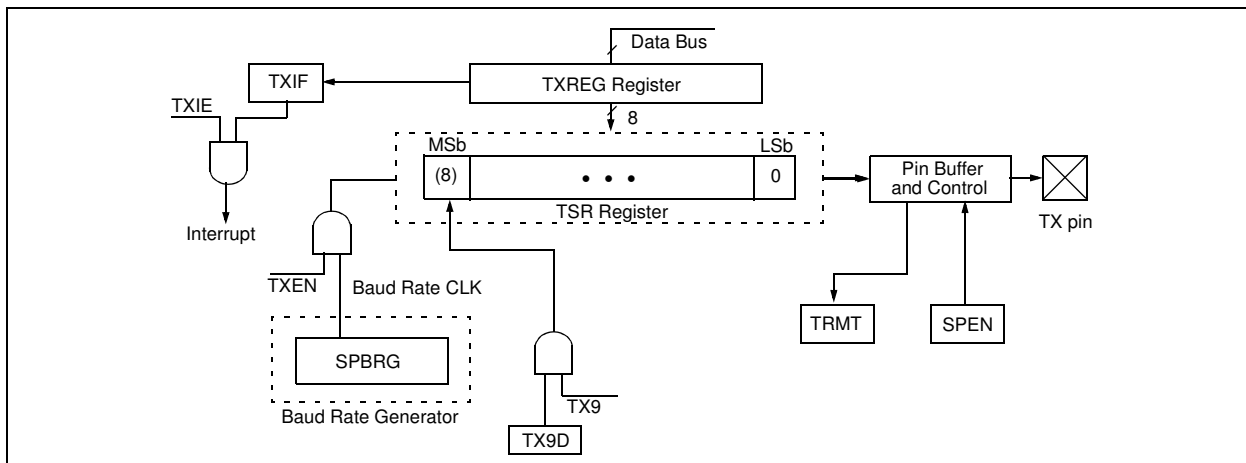

PIC18F6520/8520/6620/8620/6720/8720

FIGURE 18-2: ASYNCHRONOUS TRANSMISSION

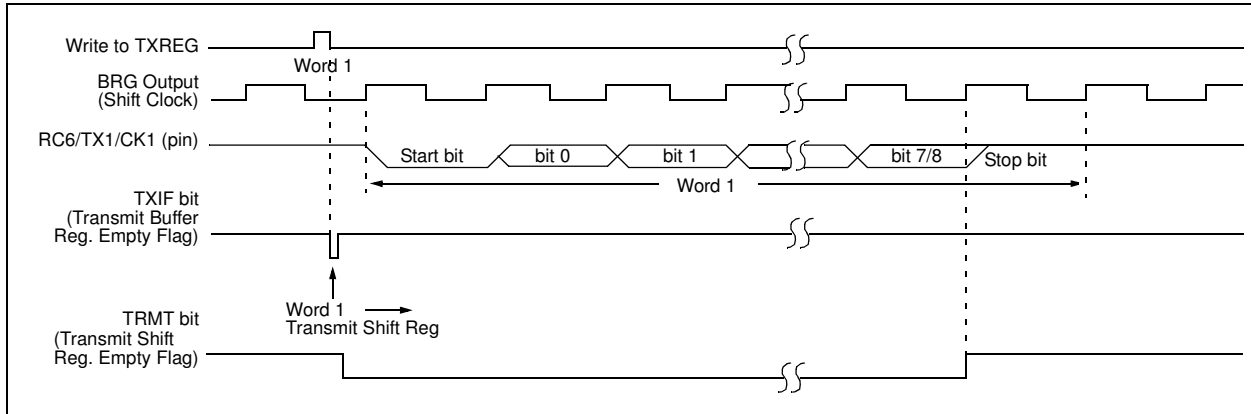

FIGURE 18-3: ASYNCHRONOUS TRANSMISSION (BACK TO BACK)

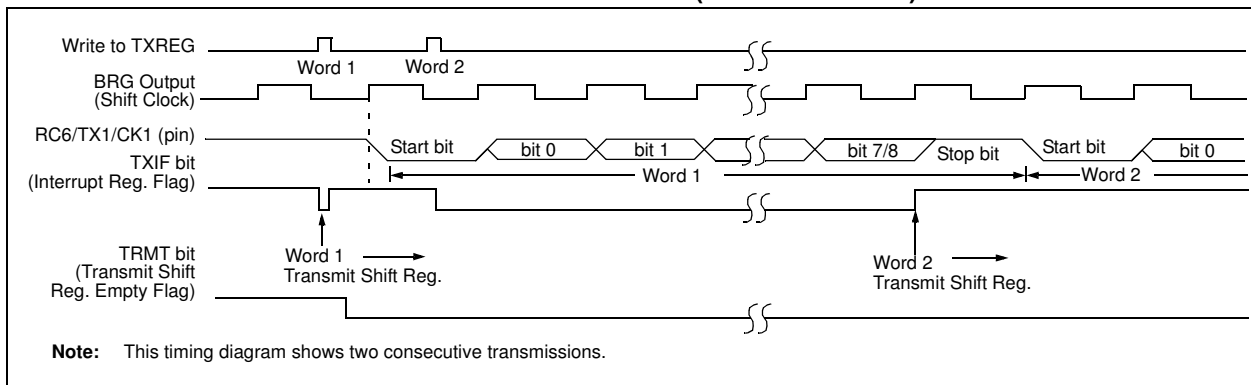

TABLE 18-6: REGISTERS ASSOCIATED WITH ASYNCHRONOUS TRANSMISSION

Name	Bit 7	Bit 6	Bit 5	Bit 4	Bit 3	Bit 2	Bit 1	Bit 0	Value on POR, BOR	Value on all other Resets
INTCON	GIE/GIEH	PEIE/GIEL	TMR0IE	INT0IE	RBIE	TMR0IF	INT0IF	RBIF	0000 0000	0000 0000
PIR1	PSPIF	ADIF	RC1IF	TX1IF	SSPIF	CCP1IF	TMR2IF	TMR1IF	0000 0000	0000 0000
PIE1	PSPIE	ADIE	RC1IE	TX1IE	SSPIE	CCP1IE	TMR2IE	TMR1IE	0000 0000	0000 0000
IPR1	PSPIP	ADIP	RC1IP	TX1IP	SSPIP	CCP1IP	TMR2IP	TMR1IP	0111 1111	0111 1111
PIR3	—	—	RC2IF	TX2IF	TMR4IF	CCP5IF	CCP4IF	CCP3IF	--00 0000	--00 0000
PIE3	—	—	RC2IE	TX2IE	TMR4IE	CCP5IE	CCP4IE	CCP3IE	--00 0000	--00 0000
IPR3	—	—	RC2IP	TX2IP	TMR4IP	CCP5IP	CCP4IP	CCP3IP	--11 1111	--11 1111
RCSTAx ⁽¹⁾	SPEN	RX9	SREN	CREN	ADDEN	FERR	OERR	RX9D	0000 000x	0000 000x
TXREGx ⁽¹⁾	USART Transmit Register								0000 0000	0000 0000
TXSTAx ⁽¹⁾	CSRC	TX9	TXEN	SYNC	—	BRGH	TRMT	TX9D	0000 -010	0000 -010
SPBRGx ⁽¹⁾	Baud Rate Generator Register								0000 0000	0000 0000

Legend: x = unknown, — = unimplemented locations read as '0'. Shaded cells are not used for asynchronous transmission.

Note 1: Register names generically refer to both of the identically named registers for the two USART modules, where 'x' indicates the particular module. Bit names and Reset values are identical between modules.

PIC18F6520/8520/6620/8620/6720/8720

18.2.2 USART ASYNCHRONOUS RECEIVER

The USART receiver block diagram is shown in Figure 18-4. The data is received on the pin (RC7/RX1/DT1 or RG2/RX2/DT2) and drives the data recovery block. The data recovery block is actually a high-speed shifter operating at 16 times the baud rate, whereas the main receive serial shifter operates at the bit rate or at Fosc. This mode would typically be used in RS-232 systems.

To set up an Asynchronous Reception:

1. Initialize the SPBRG register for the appropriate baud rate. If a high-speed baud rate is desired, set bit BRGH (Section 18.1 “USART Baud Rate Generator (BRG)”).
2. Enable the asynchronous serial port by clearing bit SYNC and setting bit SPEN.
3. If interrupts are desired, set enable bit RCxIE.
4. If 9-bit reception is desired, set bit RX9.
5. Enable the reception by setting bit CREN.
6. Flag bit RCxIF will be set when reception is complete and an interrupt will be generated if enable bit RCxIE was set.
7. Read the RCSTAx register to get the ninth bit (if enabled) and determine if any error occurred during reception.
8. Read the 8-bit received data by reading the RCREG register.
9. If any error occurred, clear the error by clearing enable bit CREN.
10. If using interrupts, ensure that the GIE and PEIE bits in the INTCON register (INTCON<7:6>) are set.

18.2.3 SETTING UP 9-BIT MODE WITH ADDRESS DETECT

This mode would typically be used in RS-485 systems. To set up an Asynchronous Reception with Address Detect Enable:

1. Initialize the SPBRGx register for the appropriate baud rate. If a high-speed baud rate is required, set the BRGH bit.
2. Enable the asynchronous serial port by clearing the SYNC bit and setting the SPEN bit.
3. If interrupts are required, set the RCEN bit and select the desired priority level with the RCIP bit.
4. Set the RX9 bit to enable 9-bit reception.
5. Set the ADDEN bit to enable address detect.
6. Enable reception by setting the CREN bit.
7. The RCxIF bit will be set when reception is complete. The interrupt will be Acknowledged if the RCxIE and GIE bits are set.
8. Read the RCSTAx register to determine if any error occurred during reception, as well as read bit 9 of data (if applicable).
9. Read RCREGx to determine if the device is being addressed.
10. If any error occurred, clear the CREN bit.
11. If the device has been addressed, clear the ADDEN bit to allow all received data into the receive buffer and interrupt the CPU.

FIGURE 18-4: USART RECEIVE BLOCK DIAGRAM

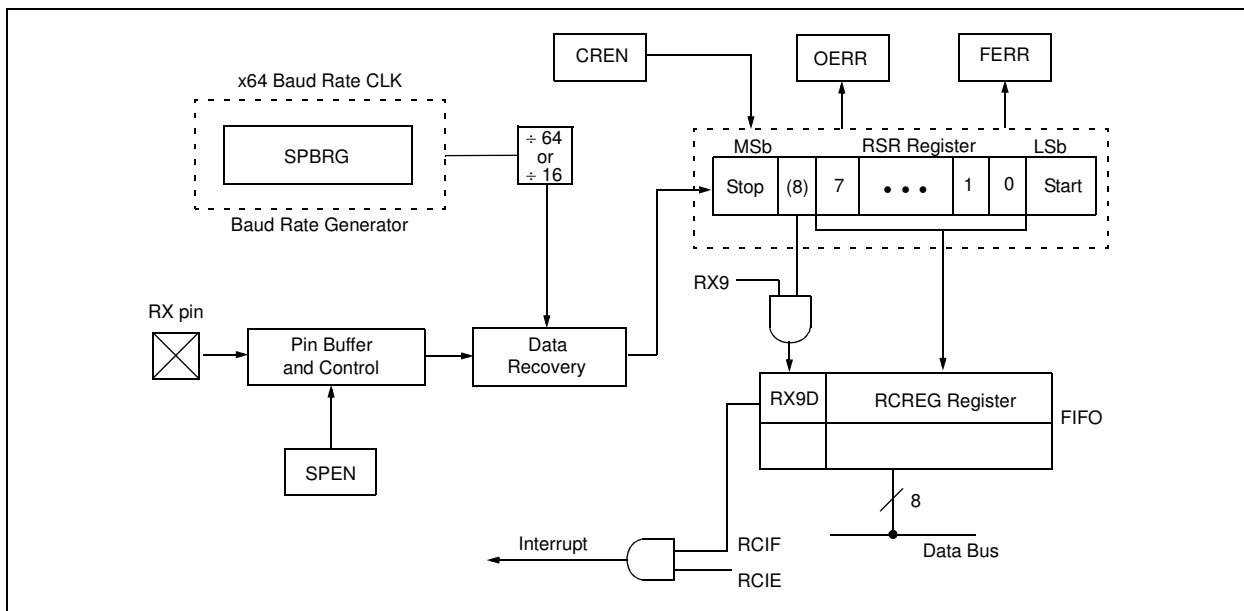

PIC18F6520/8520/6620/8620/6720/8720

FIGURE 18-5: ASYNCHRONOUS RECEPTION

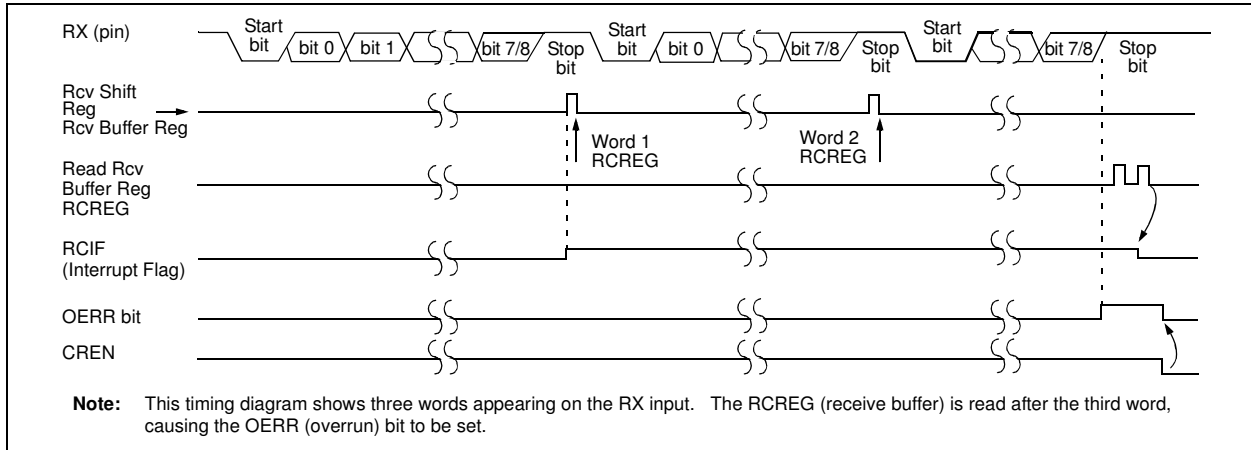

TABLE 18-7: REGISTERS ASSOCIATED WITH ASYNCHRONOUS RECEPTION

Name	Bit 7	Bit 6	Bit 5	Bit 4	Bit 3	Bit 2	Bit 1	Bit 0	Value on POR, BOR	Value on all other Resets
INTCON	GIE/GIEH	PEIE/GIEL	TMR0IE	INT0IE	RBIE	TMR0IF	INT0IF	RBIF	0000 0000	0000 0000
PIR1	PSPIF	ADIF	RC1IF	TXIF	SSPIF	CCP1IF	TMR2IF	TMR1IF	0000 0000	0000 0000
PIE1	PSPIE	ADIE	RC1IE	TXIE	SSPIE	CCP1IE	TMR2IE	TMR1IE	0000 0000	0000 0000
IPR1	PSPIP	ADIP	RC1IP	TXIP	SSPIP	CCP1IP	TMR2IP	TMR1IP	0111 1111	0111 1111
PIR3	—	—	RC2IF	TX2IF	TMR4IF	CCP5IF	CCP4IF	CCP3IF	--00 0000	--00 0000
PIE3	—	—	RC2IE	TX2IE	TMR4IE	CCP5IE	CCP4IE	CCP3IE	--00 0000	--00 0000
IPR3	—	—	RC2IP	TX2IP	TMR4IP	CCP5IP	CCP4IP	CCP3IP	--11 1111	--11 1111
RCSTAx ⁽¹⁾	SPEN	RX9	SREN	CREN	ADDEN	FERR	OERR	RX9D	0000 000x	0000 000x
RCREGx ⁽¹⁾	USART Receive Register								0000 0000	0000 0000
TXSTAx ⁽¹⁾	CSRC	TX9	TXEN	SYNC	—	BRGH	TRMT	TX9D	0000 -010	0000 -010
SPBRGx ⁽¹⁾	Baud Rate Generator Register								0000 0000	0000 0000

Legend: x = unknown, — = unimplemented locations read as '0'. Shaded cells are not used for asynchronous reception.

Note 1: Register names generically refer to both of the identically named registers for the two USART modules, where 'x' indicates the particular module. Bit names and Reset values are identical between modules.

PIC18F6520/8520/6620/8620/6720/8720

18.3 USART Synchronous Master Mode

In Synchronous Master mode, the data is transmitted in a half-duplex manner (i.e., transmission and reception do not occur at the same time). When transmitting data, the reception is inhibited and vice versa. Synchronous mode is entered by setting bit SYNC (TXSTAx<4>). In addition, enable bit SPEN (RCSTAx<7>) is set in order to configure the appropriate I/O pins to CK (clock) and DT (data) lines, respectively. The Master mode indicates that the processor transmits the master clock on the CK line. The Master mode is entered by setting bit CSRC (TXSTAx<7>).

18.3.1 USART SYNCHRONOUS MASTER TRANSMISSION

The USART transmitter block diagram is shown in Figure 18-1. The heart of the transmitter is the Transmit (Serial) Shift Register (TSR). The shift register obtains its data from the Read/Write Transmit Buffer register, TXREG. The TXREGx register is loaded with data in software. The TSR register is not loaded until the last bit has been transmitted from the previous load. As soon as the last bit is transmitted, the TSR is loaded with new data from the TXREGx (if available). Once the TXREGx register transfers the data to the TSR register (occurs in one Tcycle), the TXREGx is empty and interrupt bit TXxIF (PIR1<4> for USART1, PIR3<4> for USART2) is set. The interrupt can be enabled/disabled by setting/clearing enable bit TXxIE (PIE1<4> for USART1, PIE3<4> for USART2). Flag bit TXxIF will be

set, regardless of the state of enable bit TXxIE and cannot be cleared in software. It will reset only when new data is loaded into the TXREGx register. While flag bit TXxIF indicates the status of the TXREGx register, another bit TRMT (TXSTAx<1>) shows the status of the TSR register. TRMT is a read-only bit, which is set when the TSR is empty. No interrupt logic is tied to this bit, so the user has to poll this bit in order to determine if the TSR register is empty. The TSR is not mapped in data memory, so it is not available to the user.

To set up a Synchronous Master Transmission:

1. Initialize the SPBRG register for the appropriate baud rate (**Section 18.1 “USART Baud Rate Generator (BRG)”**).
2. Enable the synchronous master serial port by setting bits SYNC, SPEN and CSRC.
3. If interrupts are desired, set enable bit TXxIE in the appropriate PIE register.
4. If 9-bit transmission is desired, set bit TX9.
5. Enable the transmission by setting bit TXEN.
6. If 9-bit transmission is selected, the ninth bit should be loaded in bit TX9D.
7. Start transmission by loading data to the TXREGx register.

Note: TXIF is not cleared immediately upon loading data into the transmit buffer TXREG. The flag bit becomes valid in the second instruction cycle following the load instruction.

TABLE 18-8: REGISTERS ASSOCIATED WITH SYNCHRONOUS MASTER TRANSMISSION

Name	Bit 7	Bit 6	Bit 5	Bit 4	Bit 3	Bit 2	Bit 1	Bit 0	Value on POR, BOR	Value on all other Resets
INTCON	GIE/GIEH	PEIE/GIEL	TMR0IE	INT0IE	RBIE	TMR0IF	INT0IF	RBIF	0000 0000	0000 0000
PIR1	PSPIF	ADIF	RCIF	TXIF	SSPIF	CCP1IF	TMR2IF	TMR1IF	0000 0000	0000 0000
PIE1	PSPIE	ADIE	RCIE	TXIE	SSPIE	CCP1IE	TMR2IE	TMR1IE	0000 0000	0000 0000
IPR1	PSPIP	ADIP	RCIP	TXIP	SSPIP	CCP1IP	TMR2IP	TMR1IP	0111 1111	0111 1111
PIR3	—	—	RC2IF	TX2IF	TMR4IF	CCP5IF	CCP4IF	CCP3IF	--00 0000	--00 0000
PIE3	—	—	RC2IE	TX2IE	TMR4IE	CCP5IE	CCP4IE	CCP3IE	--00 0000	--00 0000
IPR3	—	—	RC2IP	TX2IP	TMR4IP	CCP5IP	CCP4IP	CCP3IP	--11 1111	--11 1111
RCSTAx ⁽¹⁾	SPEN	RX9	SREN	CREN	ADDEN	FERR	OERR	RX9D	0000 000x	0000 000x
TXREGx ⁽¹⁾	USART Transmit Register								0000 0000	0000 0000
TXSTAx ⁽¹⁾	CSRC	TX9	TXEN	SYNC	—	BRGH	TRMT	TX9D	0000 -010	0000 -010
SPBRGx ⁽¹⁾	Baud Rate Generator Register								0000 0000	0000 0000

Legend: x = unknown, — = unimplemented, read as '0'. Shaded cells are not used for synchronous master transmission.

Note 1: Register names generically refer to both of the identically named registers for the two USART modules, where 'x' indicates the particular module. Bit names and Reset values are identical between modules.

PIC18F6520/8520/6620/8620/6720/8720

FIGURE 18-6: SYNCHRONOUS TRANSMISSION

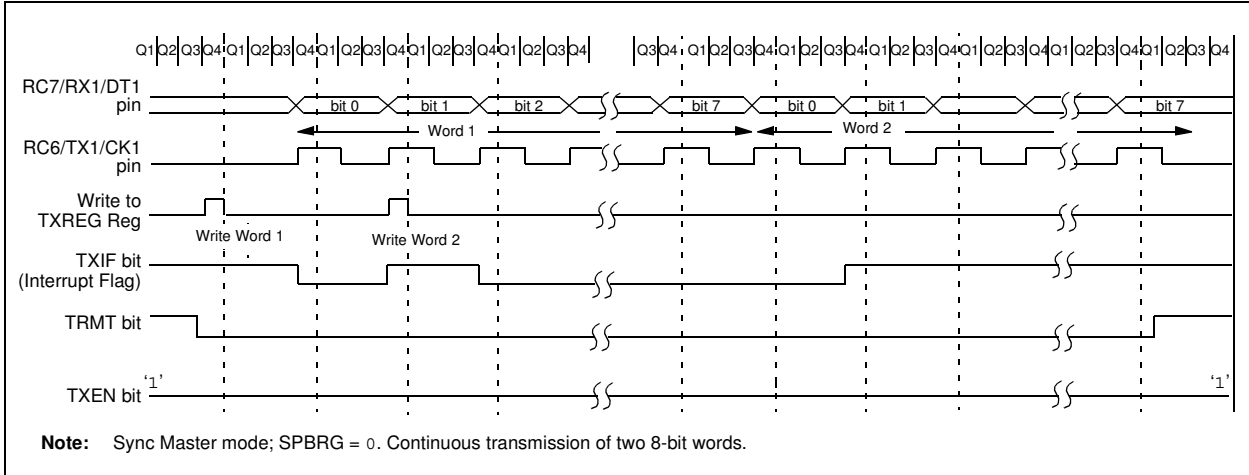
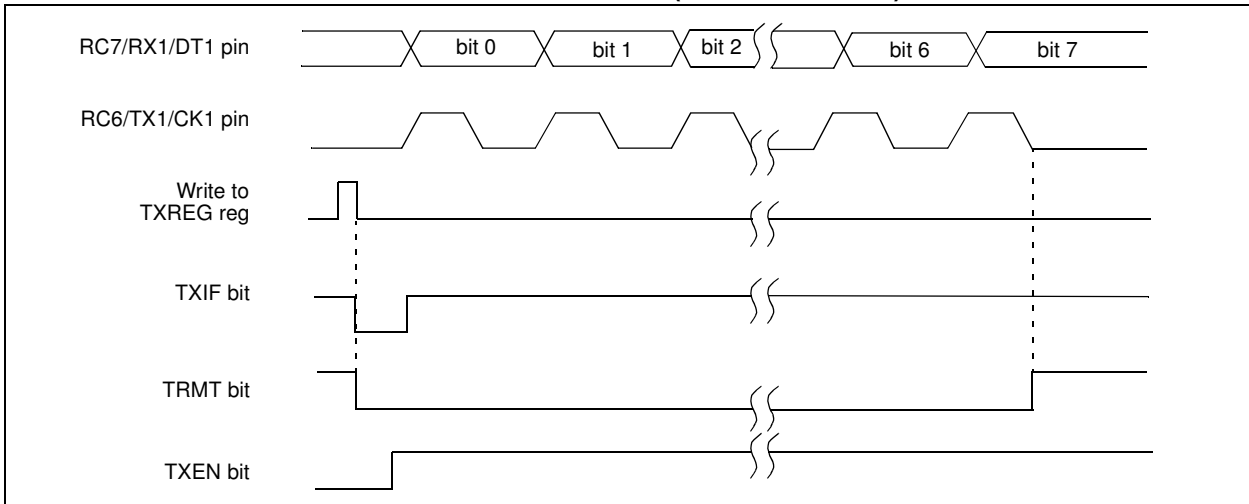

FIGURE 18-7: SYNCHRONOUS TRANSMISSION (THROUGH TXEN)



PIC18F6520/8520/6620/8620/6720/8720

18.3.2 USART SYNCHRONOUS MASTER RECEPTION

Once Synchronous mode is selected, reception is enabled by setting either enable bit SREN (RCSTAx<5>) or enable bit CREN (RCSTAx<4>). Data is sampled on the RXx pin (RC7/RX1/DT1 or RG2/RX2/DT2) on the falling edge of the clock. If enable bit SREN is set, only a single word is received. If enable bit CREN is set, the reception is continuous until CREN is cleared. If both bits are set, then CREN takes precedence.

To set up a Synchronous Master Reception:

1. Initialize the SPBRGx register for the appropriate baud rate (**Section 18.1 “USART Baud Rate Generator (BRG)”**).
2. Enable the synchronous master serial port by setting bits SYNC, SPEN and CSRC.
3. Ensure bits CREN and SREN are clear.
4. If interrupts are desired, set enable bit RCxIE in the appropriate PIE register.
5. If 9-bit reception is desired, set bit RX9.
6. If a single reception is required, set bit SREN. For continuous reception, set bit CREN.
7. Interrupt flag bit RCxIF will be set when reception is complete and an interrupt will be generated if the enable bit RCxIE was set.
8. Read the RCSTAx register to get the ninth bit (if enabled) and determine if any error occurred during reception.
9. Read the 8-bit received data by reading the RCREGx register.
10. If any error occurred, clear the error by clearing bit CREN.
11. If using interrupts, ensure that the GIE and PEIE bits in the INTCON register (INTCON<7:6>) are set.

TABLE 18-9: REGISTERS ASSOCIATED WITH SYNCHRONOUS MASTER RECEPTION

Name	Bit 7	Bit 6	Bit 5	Bit 4	Bit 3	Bit 2	Bit 1	Bit 0	Value on POR, BOR	Value on all other Resets
INTCON	GIE/GIEH	PEIE/GIEL	TMR0IE	INT0IE	RBIE	TMR0IF	INT0IF	RBIF	0000 0000	0000 0000
PIR1	PSPIF	ADIF	RC1IF	TX1IF	SSPIF	CCP1IF	TMR2IF	TMR1IF	0000 0000	0000 0000
PIE1	PSPIE	ADIE	RC1IE	TX1IE	SSPIE	CCP1IE	TMR2IE	TMR1IE	0000 0000	0000 0000
IPR1	PSPIP	ADIP	RC1IP	TX1IP	SSPIP	CCP1IP	TMR2IP	TMR1IP	0111 1111	0111 1111
PIR3	—	—	RC2IF	TX2IF	TMR4IF	CCP5IF	CCP4IF	CCP3IF	--00 0000	--00 0000
PIE3	—	—	RC2IE	TX2IE	TMR4IE	CCP5IE	CCP4IE	CCP3IE	--00 0000	--00 0000
IPR3	—	—	RC2IP	TX2IP	TMR4IP	CCP5IP	CCP4IP	CCP3IP	--11 1111	--11 1111
RCSTAx ⁽¹⁾	SPEN	RX9	SREN	CREN	ADDEN	FERR	OERR	RX9D	0000 000x	0000 000x
RCREGx ⁽¹⁾	USART Receive Register								0000 0000	0000 0000
TXSTAx ⁽¹⁾	CSRC	TX9	TXEN	SYNC	—	BRGH	TRMT	TX9D	0000 -010	0000 -010
SPBRGx ⁽¹⁾	Baud Rate Generator Register								0000 0000	0000 0000

Legend: x = unknown, – = unimplemented, read as ‘0’. Shaded cells are not used for synchronous master reception.

Note 1: Register names generically refer to both of the identically named registers for the two USART modules, where ‘x’ indicates the particular module. Bit names and Reset values are identical between modules.

FIGURE 18-8: SYNCHRONOUS RECEPTION (MASTER MODE, SREN)

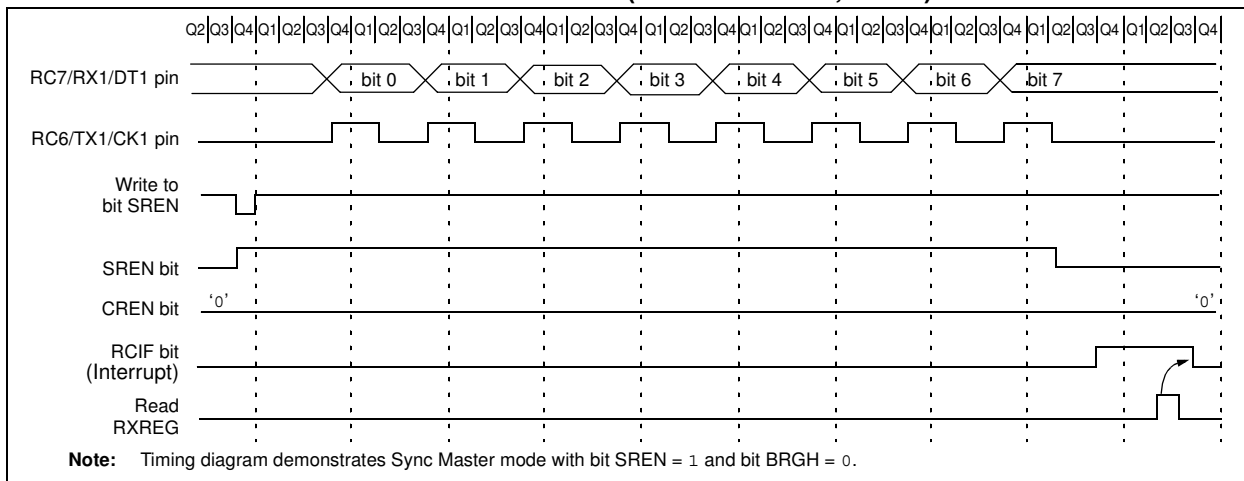

PIC18F6520/8520/6620/8620/6720/8720

18.4 USART Synchronous Slave Mode

Synchronous Slave mode differs from the Master mode in the fact that the shift clock is supplied externally at the TXx pin (RC6/TX1/CK1 or RG1/TX2/CK2), instead of being supplied internally in Master mode. TRISC<6> must be set for this mode. This allows the device to transfer or receive data while in Sleep mode. Slave mode is entered by clearing bit CSRC (TXSTAx<7>).

18.4.1 USART SYNCHRONOUS SLAVE TRANSMIT

The operation of the Synchronous Master and Slave modes are identical, except in the case of the Sleep mode.

If two words are written to the TXREG and then the SLEEP instruction is executed, the following will occur:

- The first word will immediately transfer to the TSR register and transmit.
- The second word will remain in TXREG register.
- Flag bit TXxIF will not be set.
- When the first word has been shifted out of TSR, the TXREGx register will transfer the second word to the TSR and flag bit TXxIF will now be set.
- If enable bit TXxIE is set, the interrupt will wake the chip from Sleep. If the global interrupt is enabled, the program will branch to the interrupt vector.

To set up a Synchronous Slave Transmission:

- Enable the synchronous slave serial port by setting bits SYNC and SPEN and clearing bit CSRC.
- Clear bits CREN and SREN.
- If interrupts are desired, set enable bit TXxIE.
- If 9-bit transmission is desired, set bit TX9.
- Enable the transmission by setting enable bit TXEN.
- If 9-bit transmission is selected, the ninth bit should be loaded in bit TX9D.
- Start transmission by loading data to the TXREGx register.
- If using interrupts, ensure that the GIE and PEIE bits in the INTCON register (INTCON<7:6>) are set.

TABLE 18-10: REGISTERS ASSOCIATED WITH SYNCHRONOUS SLAVE TRANSMISSION

Name	Bit 7	Bit 6	Bit 5	Bit 4	Bit 3	Bit 2	Bit 1	Bit 0	Value on POR, BOR	Value on all other Resets
INTCON	GIE/ GIEH	PEIE/ GIEL	TMR0IE	INT0IE	RBIE	TMR0IF	INT0IF	RBIF	0000 0000	0000 0000
PIR1	PSPIF	ADIF	RC1IF	TX1IF	SSPIF	CCP1IF	TMR2IF	TMR1IF	0000 0000	0000 0000
PIE1	PSPIE	ADIE	RC1IE	TX1IE	SSPIE	CCP1IE	TMR2IE	TMR1IE	0000 0000	0000 0000
IPR1	PSPIP	ADIP	RC1IP	TX1IP	SSPIP	CCP1IP	TMR2IP	TMR1IP	0111 1111	0111 1111
PIR3	—	—	RC2IF	TX2IF	TMR4IF	CCP5IF	CCP4IF	CCP3IF	--00 0000	--00 0000
PIE3	—	—	RC2IE	TX2IE	TMR4IE	CCP5IE	CCP4IE	CCP3IE	--00 0000	--00 0000
IPR3	—	—	RC2IP	TX2IP	TMR4IP	CCP5IP	CCP4IP	CCP3IP	--11 1111	--11 1111
RCSTAx ⁽¹⁾	SPEN	RX9	SREN	CREN	ADDEN	FERR	OERR	RX9D	0000 000x	0000 000x
TXREGx ⁽¹⁾	USART Transmit Register								0000 0000	0000 0000
TXSTAx ⁽¹⁾	CSRC	TX9	TXEN	SYNC	—	BRGH	TRMT	TX9D	0000 -010	0000 -010
SPBRGx ⁽¹⁾	Baud Rate Generator Register								0000 0000	0000 0000

Legend: x = unknown, — = unimplemented, read as '0'. Shaded cells are not used for synchronous slave transmission.

Note 1: Register names generically refer to both of the identically named registers for the two USART modules, where 'x' indicates the particular module. Bit names and Reset values are identical between modules.

PIC18F6520/8520/6620/8620/6720/8720

18.4.2 USART SYNCHRONOUS SLAVE RECEPTION

The operation of the Synchronous Master and Slave modes is identical, except in the case of the Sleep mode and bit SREN, which is a “don’t care” in Slave mode.

If receive is enabled by setting bit CREN prior to the SLEEP instruction, then a word may be received during Sleep. On completely receiving the word, the RSR register will transfer the data to the RCREG register and if enable bit RCxIE bit is set, the interrupt generated will wake the chip from Sleep. If the global interrupt is enabled, the program will branch to the interrupt vector.

To set up a Synchronous Slave Reception:

1. Enable the synchronous master serial port by setting bits SYNC and SPEN and clearing bit CSRC.
2. If interrupts are desired, set enable bit RCxIE.
3. If 9-bit reception is desired, set bit RX9.
4. To enable reception, set enable bit CREN.
5. Flag bit RCxIF will be set when reception is complete. An interrupt will be generated if enable bit RCxIE was set.
6. Read the RCSTAx register to get the ninth bit (if enabled) and determine if any error occurred during reception.
7. Read the 8-bit received data by reading the RCREGx register.
8. If any error occurred, clear the error by clearing bit CREN.
9. If using interrupts, ensure that the GIE and PEIE bits in the INTCON register (INTCON<7:6>) are set.

TABLE 18-11: REGISTERS ASSOCIATED WITH SYNCHRONOUS SLAVE RECEPTION

Name	Bit 7	Bit 6	Bit 5	Bit 4	Bit 3	Bit 2	Bit 1	Bit 0	Value on POR, BOR	Value on all other Resets
INTCON	GIE/ GIEH	PEIE/ GIEL	TMR0IE	INT0IE	RBIE	TMR0IF	INT0IF	RBIF	0000 0000	0000 0000
PIR1	PSPIF	ADIF	RC1IF	TX1IF	SSPIF	CCP1IF	TMR2IF	TMR1IF	0000 0000	0000 0000
PIE1	PSPIE	ADIE	RC1IE	TX1IE	SSPIE	CCP1IE	TMR2IE	TMR1IE	0000 0000	0000 0000
IPR1	PSPIP	ADIP	RC1IP	TX1IP	SSPIP	CCP1IP	TMR2IP	TMR1IP	0111 1111	0111 1111
PIR3	—	—	RC2IF	TX2IF	TMR4IF	CCP5IF	CCP4IF	CCP3IF	--00 0000	--00 0000
PIE3	—	—	RC2IE	TX2IE	TMR4IE	CCP5IE	CCP4IE	CCP3IE	--00 0000	--00 0000
IPR3	—	—	RC2IP	TX2IP	TMR4IP	CCP5IP	CCP4IP	CCP3IP	--11 1111	--11 1111
RCSTAx ⁽¹⁾	SPEN	RX9	SREN	CREN	ADDEN	FERR	OERR	RX9D	0000 000x	0000 000x
RCREGx ⁽¹⁾	USART Receive Register								0000 0000	0000 0000
TXSTAx ⁽¹⁾	CSRC	TX9	TXEN	SYNC	—	BRGH	TRMT	TX9D	0000 -010	0000 -010
SPBRGx ⁽¹⁾	Baud Rate Generator Register								0000 0000	0000 0000

Legend: x = unknown, – = unimplemented, read as ‘0’. Shaded cells are not used for synchronous slave reception.

Note 1: Register names generically refer to both of the identically named registers for the two USART modules, where ‘x’ indicates the particular module. Bit names and Reset values are identical between modules.

PIC18F6520/8520/6620/8620/6720/8720

19.0 10-BIT ANALOG-TO-DIGITAL CONVERTER (A/D) MODULE

The analog-to-digital (A/D) converter module has 12 inputs for the PIC18F6X20 devices and 16 for the PIC18F8X20 devices. This module allows conversion of an analog input signal to a corresponding 10-bit digital number.

The module has five registers:

- A/D Result High Register (ADRESH)
- A/D Result Low Register (ADRESL)
- A/D Control Register 0 (ADCON0)
- A/D Control Register 1 (ADCON1)
- A/D Control Register 2 (ADCON2)

The ADCON0 register, shown in Register 19-1, controls the operation of the A/D module. The ADCON1 register, shown in Register 19-2, configures the functions of the port pins. The ADCON2 register, shown in Register 19-3, configures the A/D clock source and justification.

REGISTER 19-1: ADCON0 REGISTER

U-0	U-0	R/W-0	R/W-0	R/W-0	R/W-0	R/W-0	R/W-0	
—	—	CHS3	CHS2	CHS1	CHS0	GO/DONE	ADON	
bit 7								bit 0

bit 7-6 **Unimplemented:** Read as '0'

bit 5-2 **CHS3:CHS0:** Analog Channel Select bits

0000 = Channel 0 (AN0)
 0001 = Channel 1 (AN1)
 0010 = Channel 2 (AN2)
 0011 = Channel 3 (AN3)
 0100 = Channel 4 (AN4)
 0101 = Channel 5 (AN5)
 0110 = Channel 6 (AN6)
 0111 = Channel 7 (AN7)
 1000 = Channel 8 (AN8)
 1001 = Channel 9 (AN9)
 1010 = Channel 10 (AN10)
 1011 = Channel 11 (AN11)
 1100 = Channel 12 (AN12)⁽¹⁾
 1101 = Channel 13 (AN13)⁽¹⁾
 1110 = Channel 14 (AN14)⁽¹⁾
 1111 = Channel 15 (AN15)⁽¹⁾

Note 1: These channels are not available on the PIC18F6X20 (64-pin) devices.

bit 1 **GO/DONE:** A/D Conversion Status bit

When **ADON = 1:**

1 = A/D conversion in progress (setting this bit starts the A/D conversion, which is automatically cleared by hardware when the A/D conversion is complete)
 0 = A/D conversion not in progress

bit 0 **ADON:** A/D On bit

1 = A/D converter module is enabled
 0 = A/D converter module is disabled

Legend:

R = Readable bit	W = Writable bit	U = Unimplemented bit, read as '0'
- n = Value at POR	'1' = Bit is set	'0' = Bit is cleared x = Bit is unknown

PIC18F6520/8520/6620/8620/6720/8720

REGISTER 19-2: ADCON1 REGISTER

U-0	U-0	R/W-0	R/W-0	R/W-0	R/W-0	R/W-0	R/W-0	
—	—	VCFG1	VCFG0	PCFG3	PCFG2	PCFG1	PCFG0	
bit 7								bit 0

bit 7-6 **Unimplemented:** Read as '0'

bit 5-4 **VCFG1:VCFG0:** Voltage Reference Configuration bits:

VCFG1 VCFG0	A/D VREF+	A/D VREF-
00	AVDD	AVSS
01	External VREF+	AVSS
10	AVDD	External VREF-
11	External VREF+	External VREF-

bit 3-0 **PCFG3:PCFG0:** A/D Port Configuration Control bits:

PCFG3 PCFG0	AN15	AN14	AN13	AN12	AN11	AN10	AN9	AN8	AN7	AN6	AN5	AN4	AN3	AN2	AN1	AN0
0000	A	A	A	A	A	A	A	A	A	A	A	A	A	A	A	A
0001	D	D	A	A	A	A	A	A	A	A	A	A	A	A	A	A
0010	D	D	D	A	A	A	A	A	A	A	A	A	A	A	A	A
0011	D	D	D	D	A	A	A	A	A	A	A	A	A	A	A	A
0100	D	D	D	D	D	A	A	A	A	A	A	A	A	A	A	A
0101	D	D	D	D	D	D	A	A	A	A	A	A	A	A	A	A
0110	D	D	D	D	D	D	D	A	A	A	A	A	A	A	A	A
0111	D	D	D	D	D	D	D	D	A	A	A	A	A	A	A	A
1000	D	D	D	D	D	D	D	D	D	A	A	A	A	A	A	A
1001	D	D	D	D	D	D	D	D	D	D	A	A	A	A	A	A
1010	D	D	D	D	D	D	D	D	D	D	D	A	A	A	A	A
1011	D	D	D	D	D	D	D	D	D	D	D	D	A	A	A	A
1100	D	D	D	D	D	D	D	D	D	D	D	D	D	A	A	A
1101	D	D	D	D	D	D	D	D	D	D	D	D	D	D	A	A
1110	D	D	D	D	D	D	D	D	D	D	D	D	D	D	D	A
1111	D	D	D	D	D	D	D	D	D	D	D	D	D	D	D	D

A = Analog input D = Digital I/O

Note: Shaded cells indicate A/D channels available only on PIC18F8X20 devices.

Legend:			
R = Readable bit	W = Writable bit	U = Unimplemented bit, read as '0'	
- n = Value at POR	'1' = Bit is set	'0' = Bit is cleared	x = Bit is unknown

PIC18F6520/8520/6620/8620/6720/8720

REGISTER 19-3: ADCON2 REGISTER

R/W-0	U-0	U-0	U-0	U-0	R/W-0	R/W-0	R/W-0
ADFM	—	—	—	—	ADCS2	ADCS1	ADCS0
bit 7							bit 0

- bit 7 **ADFM:** A/D Result Format Select bit
 1 = Right justified
 0 = Left justified
- bit 6-3 **Unimplemented:** Read as '0'
- bit 2-0 **ADCS1:ADCS0:** A/D Conversion Clock Select bits
 000 = Fosc/2
 001 = Fosc/8
 010 = Fosc/32
 011 = FRC (clock derived from an RC oscillator = 1 MHz max)
 100 = Fosc/4
 101 = Fosc/16
 110 = Fosc/64
 111 = FRC (clock derived from an RC oscillator = 1 MHz max)

Legend:

R = Readable bit	W = Writable bit	U = Unimplemented bit, read as '0'
- n = Value at POR	'1' = Bit is set	'0' = Bit is cleared x = Bit is unknown

The analog reference voltage is software selectable to either the device's positive and negative supply voltage (VDD and VSS), or the voltage level on the RA3/AN3/VREF+ pin and RA2/AN2/VREF- pin.

The A/D converter has a unique feature of being able to operate while the device is in Sleep mode. To operate in Sleep, the A/D conversion clock must be derived from the A/D's internal RC oscillator.

The output of the sample and hold is the input into the converter, which generates the result via successive approximation.

A device Reset forces all registers to their Reset state. This forces the A/D module to be turned off and any conversion is aborted.

Each port pin associated with the A/D converter can be configured as an analog input (RA3 can also be a voltage reference), or as a digital I/O. The ADRESH and ADRESL registers contain the result of the A/D conversion. When the A/D conversion is complete, the result is loaded into the ADRESH/ADRESL registers, the GO/DONE bit (ADCON0 register) is cleared and A/D interrupt flag bit, ADIF, is set. The block diagram of the A/D module is shown in Figure 19-1.

PIC18F6520/8520/6620/8620/6720/8720

FIGURE 19-1: A/D BLOCK DIAGRAM

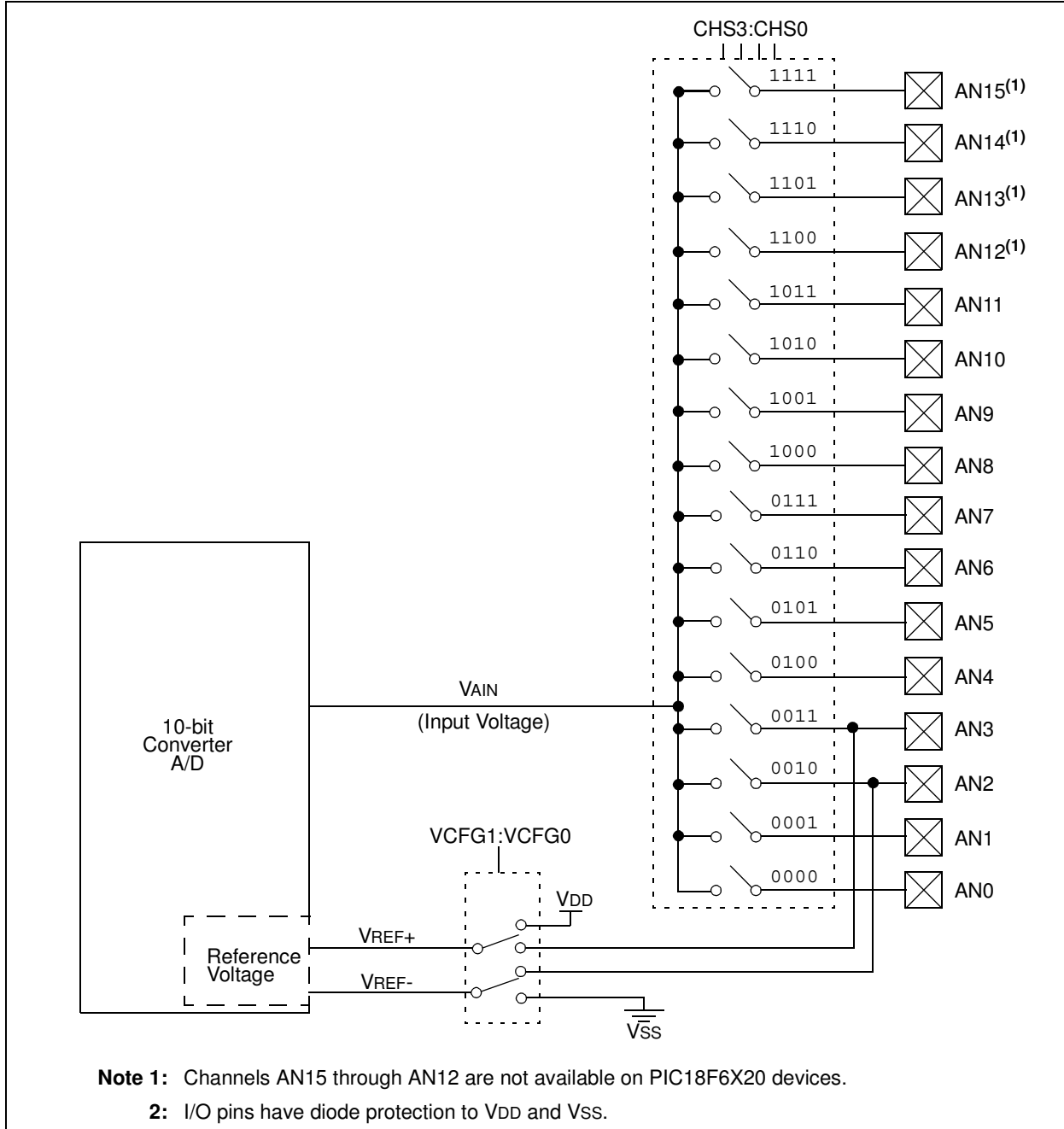

PIC18F6520/8520/6620/8620/6720/8720

The value in the ADRESH/ADRESL registers is not modified for a Power-on Reset. The ADRESH/ADRESL registers will contain unknown data after a Power-on Reset.

After the A/D module has been configured as desired, the selected channel must be acquired before the conversion is started. The analog input channels must have their corresponding TRIS bits selected as an input. To determine acquisition time, see **Section 19.1 “A/D Acquisition Requirements”**. After this acquisition time has elapsed, the A/D conversion can be started.

The following steps should be followed to do an A/D conversion:

1. Configure the A/D module:
 - Configure analog pins, voltage reference and digital I/O (ADCON1)
 - Select A/D input channel (ADCON0)
 - Select A/D conversion clock (ADCON2)
 - Turn on A/D module (ADCON0)
2. Configure A/D interrupt (if desired):
 - Clear ADIF bit
 - Set ADIE bit
 - Set GIE bit
3. Wait the required acquisition time.
4. Start conversion:
 - Set GO/DONE bit (ADCON0 register)
5. Wait for A/D conversion to complete, by either:
 - Polling for the GO/DONE bit to be cleared OR
 - Waiting for the A/D interrupt
6. Read A/D Result registers (ADRESH:ADRESL); clear bit ADIF, if required.
7. For the next conversion, go to step 1 or step 2, as required. The A/D conversion time per bit is defined as TAD. A minimum wait of 2 TAD is required before the next acquisition starts.

FIGURE 19-2: ANALOG INPUT MODEL

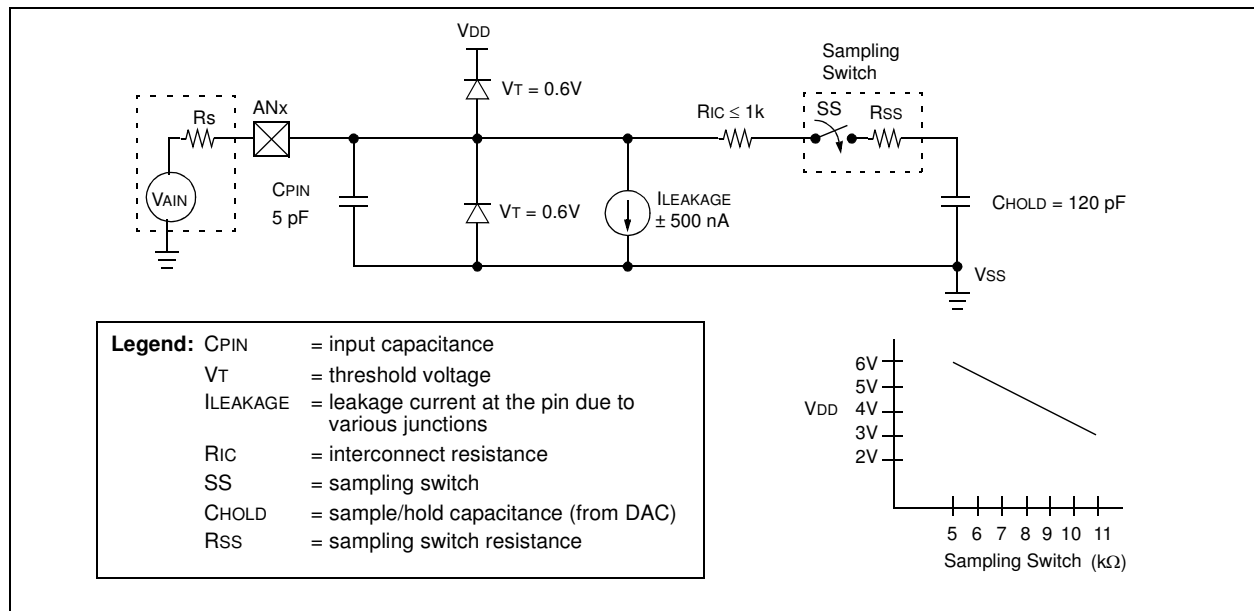

PIC18F6520/8520/6620/8620/6720/8720

19.1 A/D Acquisition Requirements

For the A/D converter to meet its specified accuracy, the charge holding capacitor (CHOLD) must be allowed to fully charge to the input channel voltage level. The analog input model is shown in Figure 19-2. The source impedance (Rs) and the internal sampling switch (Rss) impedance directly affect the time required to charge the capacitor CHOLD. The sampling switch (Rss) impedance varies over the device voltage (VDD). The source impedance affects the offset voltage at the analog input (due to pin leakage current). **The maximum recommended impedance for analog sources is 2.5 kΩ.** After the analog input channel is selected (changed), this acquisition must be done before the conversion can be started.

Note: When the conversion is started, the holding capacitor is disconnected from the input pin.

To calculate the minimum acquisition time, Equation 19-1 may be used. This equation assumes that 1/2 LSB error is used (1024 steps for the A/D). The 1/2 LSB error is the maximum error allowed for the A/D to meet its specified resolution.

Example 19-1 shows the calculation of the minimum required acquisition time, TACQ. This calculation is based on the following application system assumptions:

CHOLD	=	120 pF
Rs	=	2.5 kΩ
Conversion Error	≤	1/2 LSB
VDD	=	5V → Rss = 7 kΩ
Temperature	=	50°C (system max.)
VHOLD	=	0V @ time = 0

Note: When using external voltage references with the A/D converter, the source impedance of the external voltage references must be less than 20Ω to obtain the A/D performance specified in parameters A01-A06. Higher reference source impedances will increase both offset and gain errors. Resistive voltage dividers will not provide a sufficiently low source impedance.

To maintain the best possible performance in A/D conversions, external VREF inputs should be buffered with an operational amplifier or other low output impedance circuit.

If deviating from the operating conditions specified for parameters A03-A06, the effect of parameter A50 (VREF input current) must be considered.

EQUATION 19-1: ACQUISITION TIME

$$\begin{aligned}TACQ &= \text{Amplifier Settling Time} + \text{Holding Capacitor Charging Time} + \text{Temperature Coefficient} \\ &= TAMP + TC + TCOFF\end{aligned}$$

EQUATION 19-2: A/D MINIMUM CHARGING TIME

$$\begin{aligned}VHOLD &= (VREF - (VREF/2048)) \cdot (1 - e^{-(Tc/CHOLD)(RIC + RSS + RS)}) \\ \text{or} \\ TC &= -(120 \text{ pF})(1 \text{ k}\Omega + RSS + RS) \ln(1/2047)\end{aligned}$$

EXAMPLE 19-1: CALCULATING THE MINIMUM REQUIRED ACQUISITION TIME

$$\begin{aligned}TACQ &= TAMP + TC + TCOFF \\ \text{Temperature coefficient is only required for temperatures } > 25^\circ\text{C.} \\ TACQ &= 2 \mu\text{s} + TC + [(Temp - 25^\circ\text{C})(0.05 \mu\text{s}/^\circ\text{C})] \\ TC &= -CHOLD (RIC + RSS + RS) \ln(1/2047) \\ &= -120 \text{ pF} (1 \text{ k}\Omega + 7 \text{ k}\Omega + 2.5 \text{ k}\Omega) \ln(0.0004885) \\ &= -120 \text{ pF} (10.5 \text{ k}\Omega) \ln(0.0004885) \\ &= -1.26 \mu\text{s} (-7.6241) \\ &= 9.61 \mu\text{s} \\ TACQ &= 2 \mu\text{s} + 9.61 \mu\text{s} + [(50^\circ\text{C} - 25^\circ\text{C})(0.05 \mu\text{s}/^\circ\text{C})] \\ &= 11.61 \mu\text{s} + 1.25 \mu\text{s} \\ &= 12.86 \mu\text{s}\end{aligned}$$

PIC18F6520/8520/6620/8620/6720/8720

19.2 Selecting the A/D Conversion Clock

The A/D conversion time per bit is defined as T_{AD} . The A/D conversion requires 12 T_{AD} per 10-bit conversion. The source of the A/D conversion clock is software selectable. There are seven possible options for T_{AD} :

- 2 T_{OSC}
- 4 T_{OSC}
- 8 T_{OSC}
- 16 T_{OSC}
- 32 T_{OSC}
- 64 T_{OSC}
- Internal RC oscillator

For correct A/D conversions, the A/D conversion clock (T_{AD}) must be selected to ensure a minimum T_{AD} time of 1.6 μs .

Table 19-1 shows the resultant T_{AD} times derived from the device operating frequencies and the A/D clock source selected.

19.3 Configuring Analog Port Pins

The $ADCON1$, $TRISA$, $TRISF$ and $TRISH$ registers control the operation of the A/D port pins. The port pins needed as analog inputs must have their corresponding TRIS bits set (input). If the TRIS bit is cleared (output), the digital output level (V_{OH} or V_{OL}) will be converted.

The A/D operation is independent of the state of the $CHS3:CHS0$ bits and the TRIS bits.

Note 1: When reading the port register, all pins configured as analog input channels will read as cleared (a low level). Pins configured as digital inputs will convert as an analog input. Analog levels on a digitally configured input will not affect the conversion accuracy.

2: Analog levels on any pin defined as a digital input may cause the input buffer to consume current out of the device's specification limits.

TABLE 19-1: T_{AD} vs. DEVICE OPERATING FREQUENCIES

AD Clock Source (T_{AD})		Maximum Device Frequency	
Operation	ADCS2:ADCS0	PIC18FXX20	PIC18LFXX20
2 T_{OSC}	000	1.25 MHz	666 kHz
4 T_{OSC}	100	2.50 MHz	1.33 MHz
8 T_{OSC}	001	5.00 MHz	2.67 MHz
16 T_{OSC}	101	10.0 MHz	5.33 MHz
32 T_{OSC}	010	20.0 MHz	10.67 MHz
64 T_{OSC}	110	40.0 MHz	21.33 MHz
RC	x11	—	—

PIC18F6520/8520/6620/8620/6720/8720

19.4 A/D Conversions

Figure 19-3 shows the operation of the A/D converter after the GO bit has been set. Clearing the GO/DONE bit during a conversion will abort the current conversion. The A/D Result register pair will NOT be updated with the partially completed A/D conversion sample. That is, the ADRESH:ADRESL registers will continue to contain the value of the last completed conversion (or the last value written to the ADRESH:ADRESL registers). After the A/D conversion is aborted, a 2 TAD wait is required before the next acquisition is started. After this 2 TAD wait, acquisition on the selected channel is automatically started.

Note: The GO/DONE bit should **NOT** be set in the same instruction that turns on the A/D.

19.5 Use of the CCP2 Trigger

An A/D conversion can be started by the “special event trigger” of the CCP2 module. This requires that the CCP2M3:CCP2M0 bits (CCP2CON<3:0>) be programmed as ‘1011’ and that the A/D module is enabled (ADON bit is set). When the trigger occurs, the GO/DONE bit will be set, starting the A/D conversion and the Timer1 (or Timer3) counter will be reset to zero. Timer1 (or Timer3) is reset to automatically repeat the A/D acquisition period with minimal software overhead (moving ADRESH/ADRESL to the desired location). The appropriate analog input channel must be selected and the minimum acquisition done before the “special event trigger” sets the GO/DONE bit (starts a conversion).

If the A/D module is not enabled (ADON is cleared), the “special event trigger” will be ignored by the A/D module, but will still reset the Timer1 (or Timer3) counter.

FIGURE 19-3: A/D CONVERSION TAD CYCLES

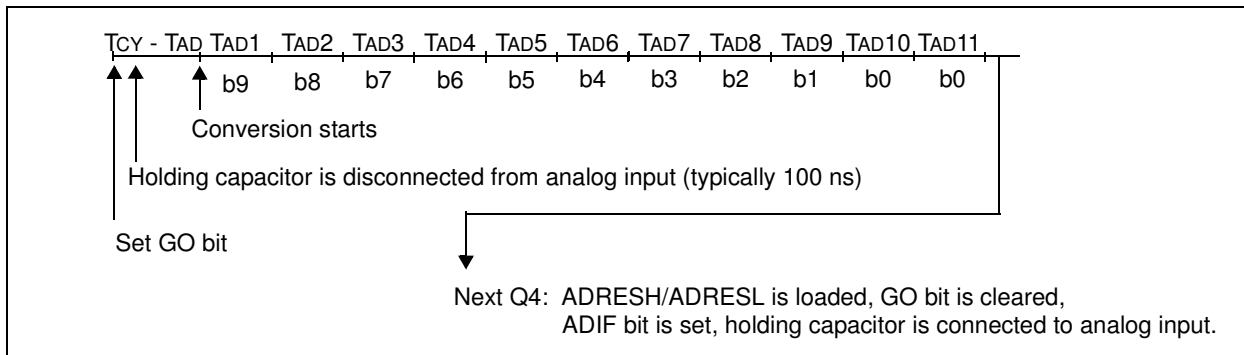

PIC18F6520/8520/6620/8620/6720/8720

TABLE 19-2: SUMMARY OF A/D REGISTERS

Name	Bit 7	Bit 6	Bit 5	Bit 4	Bit 3	Bit 2	Bit 1	Bit 0	Value on POR, BOR	Value on all other Resets
INTCON	GIE/ GIEH	PEIE/ GIEL	TMR0IE	INT0IE	RBIE	TMR0IF	INT0IF	RBIF	0000 0000	0000 0000
PIR1	PSPIF	ADIF	RCIF	TXIF	SSPIF	CCP1IF	TMR2IF	TMR1IF	0000 0000	0000 0000
PIE1	PSPIE	ADIE	RCIE	TXIE	SSPIE	CCP1IE	TMR2IE	TMR1IE	0000 0000	0000 0000
IPR1	PSPIP	ADIP	RCIP	TXIP	SSPIP	CCP1IP	TMR2IP	TMR1IP	0111 1111	0111 1111
PIR2	—	CMIF	—	—	BCLIF	LVDIF	TMR3IF	CCP2IF	-0-- 0000	-0-- 0000
PIE2	—	CMIE	—	—	BCLIE	LVDIE	TMR3IE	CCP2IE	-0-- 0000	-0-- 0000
IPR2	—	CMIP	—	—	BCLIP	LVDIP	TMR3IP	CCP2IP	-0-- 0000	-0-- 0000
ADRESH	A/D Result Register High Byte								xxxx xxxx	uuuu uuuu
ADRESL	A/D Result Register Low Byte								xxxx xxxx	uuuu uuuu
ADCON0	—	—	CHS3	CHS3	CHS1	CHS0	GO/DONE	ADON	--00 0000	--00 0000
ADCON1	—	—	VCFG1	VCFG0	PCFG3	PCFG2	PCFG1	PCFG0	--00 0000	--00 0000
ADCON2	ADFM	—	—	—	—	ADCS2	ADCS1	ADCS0	0--- -000	0--- -000
PORTA	—	RA6	RA5	RA4	RA3	RA2	RA1	RA0	--0x 0000	--0u 0000
TRISA	—	PORTA Data Direction Register							--11 1111	--11 1111
PORTF	RF7	RF6	RF5	RF4	RF3	RF2	RF1	RF0	x000 0000	u000 0000
LATF	LATF7	LATF6	LATF5	LATF4	LATF3	LATF2	LATF1	LATF0	xxxx xxxx	uuuu uuuu
TRISF	PORTF Data Direction Control Register								1111 1111	1111 1111
PORTH ⁽¹⁾	RH7	RH6	RH5	RH4	RH3	RH2	RH1	RH0	0000 xxxx	0000 xxxx
LATH ⁽¹⁾	LATH7	LATH6	LATH5	LATH4	LATH3	LATH2	LATH1	LATH0	xxxx xxxx	uuuu uuuu
TRISH ⁽¹⁾	PORTH Data Direction Control Register								1111 1111	1111 1111

Legend: x = unknown, u = unchanged, — = unimplemented, read as '0'. Shaded cells are not used for A/D conversion.

Note 1: Only available on PIC18F8X20 devices.

PIC18F6520/8520/6620/8620/6720/8720

NOTES:

PIC18F6520/8520/6620/8620/6720/8720

20.0 COMPARATOR MODULE

The comparator module contains two analog comparators. The inputs to the comparators are multiplexed with the RF1 through RF6 pins. The on-chip voltage reference (Section 21.0 “Comparator Voltage Reference Module”) can also be an input to the comparators.

The CMCON register, shown as Register 20-1, controls the comparator input and output multiplexers. A block diagram of the various comparator configurations is shown in Figure 20-1.

REGISTER 20-1: CMCON REGISTER

R-0	R-0	R/W-0	R/W-0	R/W-0	R/W-0	R/W-0	R/W-0
C2OUT	C1OUT	C2INV	C1INV	CIS	CM2	CM1	CM0
bit 7						bit 0	

bit 7 **C2OUT**: Comparator 2 Output bit

When C2INV = 0:

1 = C2 VIN+ > C2 VIN-

0 = C2 VIN+ < C2 VIN-

When C2INV = 1:

1 = C2 VIN+ < C2 VIN-

0 = C2 VIN+ > C2 VIN-

bit 6 **C1OUT**: Comparator 1 Output bit

When C1INV = 0:

1 = C1 VIN+ > C1 VIN-

0 = C1 VIN+ < C1 VIN-

When C1INV = 1:

1 = C1 VIN+ < C1 VIN-

0 = C1 VIN+ > C1 VIN-

bit 5 **C2INV**: Comparator 2 Output Inversion bit

1 = C2 output inverted

0 = C2 output not inverted

bit 4 **C1INV**: Comparator 1 Output Inversion bit

1 = C1 output inverted

0 = C1 output not inverted

bit 3 **CIS**: Comparator Input Switch bit

When CM2:CM0 = 110:

1 = C1 VIN- connects to RF5/AN10

C2 VIN- connects to RF3/AN8

0 = C1 VIN- connects to RF6/AN11

C2 VIN- connects to RF4/AN9

bit 2-0 **CM2:CM0**: Comparator Mode bits

Figure 20-1 shows the Comparator modes and the CM2:CM0 bit settings.

Legend:

R = Readable bit

W = Writable bit

U = Unimplemented bit, read as '0'

- n = Value at POR

'1' = Bit is set

'0' = Bit is cleared

x = Bit is unknown

PIC18F6520/8520/6620/8620/6720/8720

20.1 Comparator Configuration

There are eight modes of operation for the comparators. The CMCON register is used to select these modes. Figure 20-1 shows the eight possible modes. The TRISF register controls the data direction of the comparator pins for each mode. If the Comparator mode is changed, the comparator output level may not

be valid for the specified mode change delay shown in the Electrical Specifications (Section 26.0 “Electrical Characteristics”).

Note: Comparator interrupts should be disabled during a Comparator mode change. Otherwise, a false interrupt may occur.

FIGURE 20-1: COMPARATOR I/O OPERATING MODES

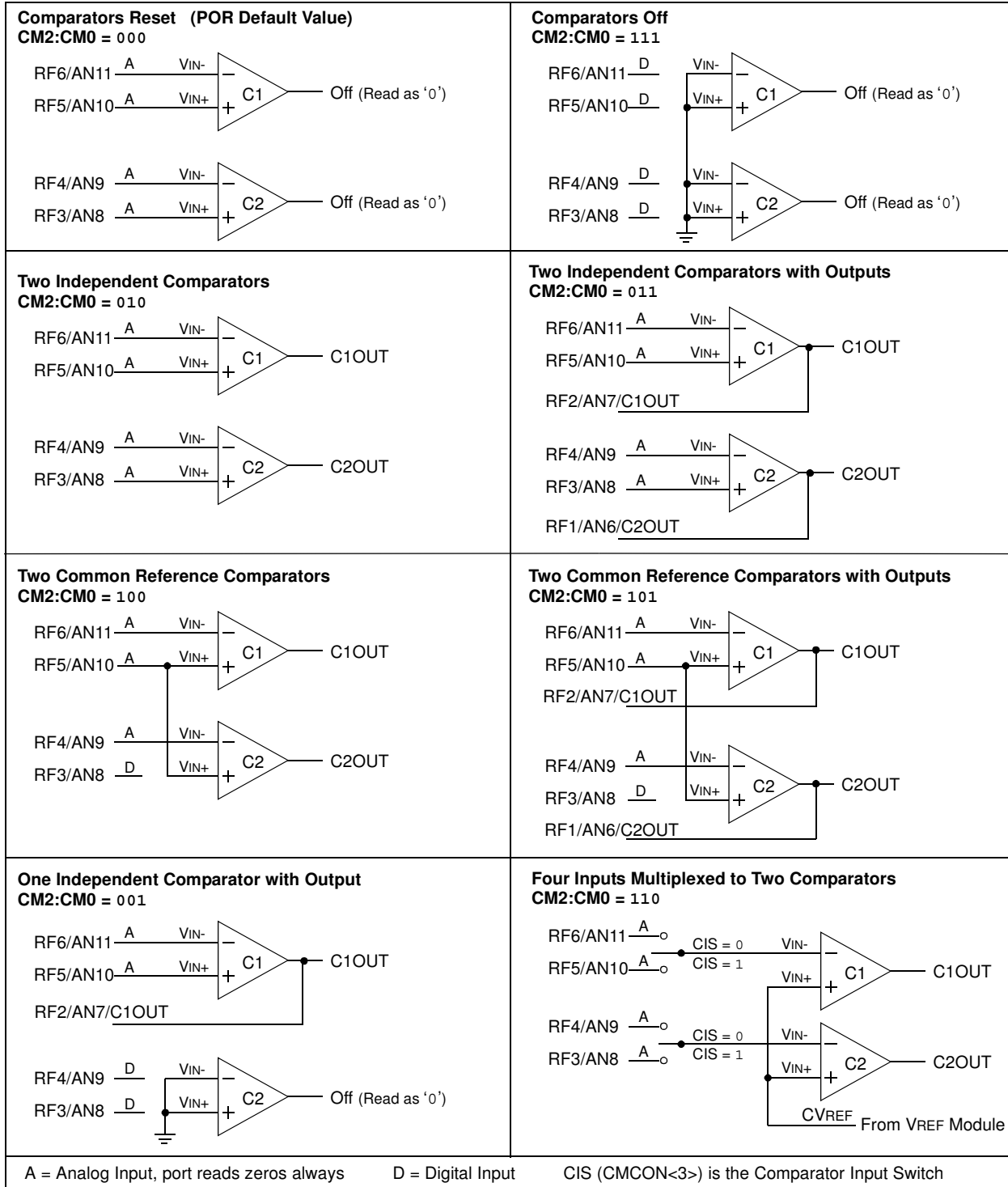

20.2 Comparator Operation

A single comparator is shown in Figure 20-2, along with the relationship between the analog input levels and the digital output. When the analog input at V_{IN+} is less than the analog input V_{IN-} , the output of the comparator is a digital low level. When the analog input at V_{IN+} is greater than the analog input V_{IN-} , the output of the comparator is a digital high level. The shaded areas of the output of the comparator in Figure 20-2 represent the uncertainty, due to input offsets and response time.

20.3 Comparator Reference

An external or internal reference signal may be used, depending on the comparator operating mode. The analog signal present at V_{IN-} is compared to the signal at V_{IN+} and the digital output of the comparator is adjusted accordingly (Figure 20-2).

FIGURE 20-2: SINGLE COMPARATOR

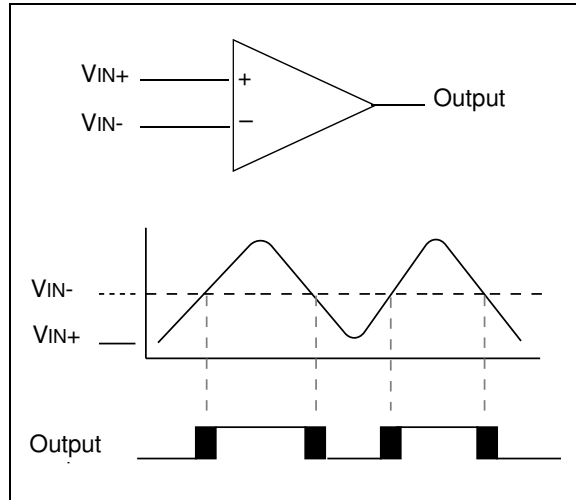

20.3.1 EXTERNAL REFERENCE SIGNAL

When external voltage references are used, the comparator module can be configured to have the comparators operate from the same, or different reference sources. However, threshold detector applications may require the same reference. The reference signal must be between V_{SS} and V_{DD} and can be applied to either pin of the comparator(s).

20.3.2 INTERNAL REFERENCE SIGNAL

The comparator module also allows the selection of an internally generated voltage reference for the comparators. **Section 21.0 “Comparator Voltage Reference Module”** contains a detailed description of the comparator voltage reference module that provides this signal. The internal reference signal is used when comparators are in mode $CM\langle 2:0 \rangle = 110$ (Figure 20-1). In this mode, the internal voltage reference is applied to the V_{IN+} pin of both comparators.

20.4 Comparator Response Time

Response time is the minimum time, after selecting a new reference voltage or input source, before the comparator output has a valid level. If the internal reference is changed, the maximum delay of the internal voltage reference must be considered when using the comparator outputs. Otherwise, the maximum delay of the comparators should be used (**Section 26.0 “Electrical Characteristics”**).

20.5 Comparator Outputs

The comparator outputs are read through the CMCON register. These bits are read-only. The comparator outputs may also be directly output to the RF1 and RF2 I/O pins. When enabled, multiplexors in the output path of the RF1 and RF2 pins will switch and the output of each pin will be the unsynchronized output of the comparator. The uncertainty of each of the comparators is related to the input offset voltage and the response time given in the specifications. Figure 20-3 shows the comparator output block diagram.

The TRISF bits will still function as an output enable/disable for the RF1 and RF2 pins while in this mode.

The polarity of the comparator outputs can be changed using the C2INV and C1INV bits ($CMCON\langle 4:5 \rangle$).

Note 1: When reading the port register, all pins configured as analog inputs will read as a '0'. Pins configured as digital inputs will convert an analog input, according to the Schmitt Trigger input specification.

2: Analog levels on any pin defined as a digital input may cause the input buffer to consume more current than is specified.

PIC18F6520/8520/6620/8620/6720/8720

FIGURE 20-3: COMPARATOR OUTPUT BLOCK DIAGRAM

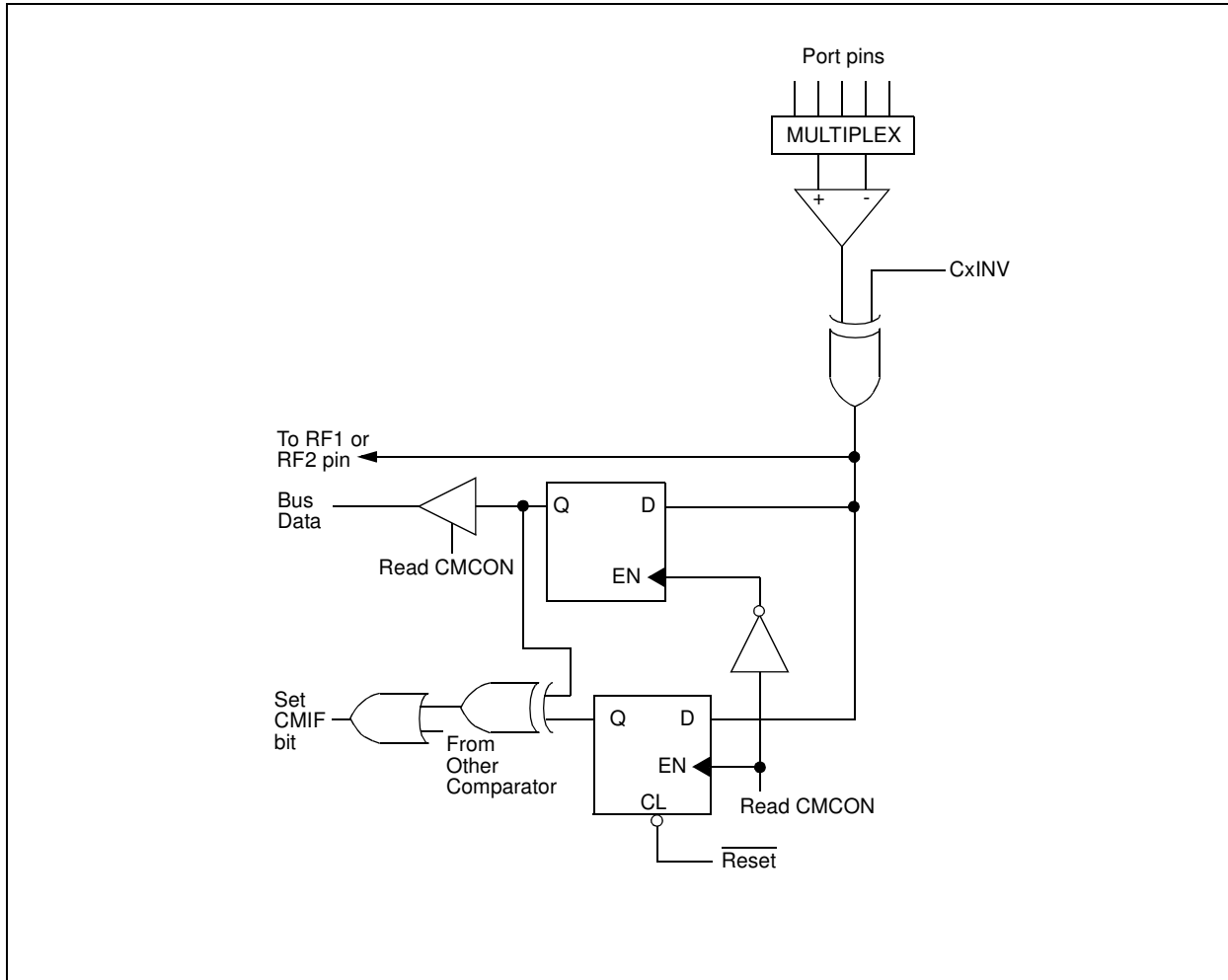

20.6 Comparator Interrupts

The comparator interrupt flag is set whenever there is a change in the output value of either comparator. Software will need to maintain information about the status of the output bits, as read from CMCON<7:6>, to determine the actual change that occurred. The CMIF bit (PIR registers) is the Comparator Interrupt Flag. The CMIF bit must be reset by clearing '0'. Since it is also possible to write a '1' to this register, a simulated interrupt may be initiated.

The CMIE bit (PIE registers) and the PEIE bit (INTCON register) must be set to enable the interrupt. In addition, the GIE bit must also be set. If any of these bits are clear, the interrupt is not enabled, though the CMIF bit will still be set if an interrupt condition occurs.

Note: If a change in the CMCON register (C1OUT or C2OUT) should occur when a read operation is being executed (start of the Q2 cycle), then the CMIF (PIR registers) interrupt flag may not get set.

The user, in the Interrupt Service Routine, can clear the interrupt in the following manner:

- Any read or write of CMCON will end the mismatch condition.
- Clear flag bit CMIF.

A mismatch condition will continue to set flag bit CMIF. Reading CMCON will end the mismatch condition and allow flag bit CMIF to be cleared.

PIC18F6520/8520/6620/8620/6720/8720

20.7 Comparator Operation During Sleep

When a comparator is active and the device is placed in Sleep mode, the comparator remains active and the interrupt is functional, if enabled. This interrupt will wake-up the device from Sleep mode, when enabled. While the comparator is powered up, higher Sleep currents than shown in the power-down current specification will occur. Each operational comparator will consume additional current, as shown in the comparator specifications. To minimize power consumption while in Sleep mode, turn off the comparators ($CM\langle 2:0 \rangle = 111$) before entering Sleep. If the device wakes up from Sleep, the contents of the CMCON register are not affected.

20.8 Effects of a Reset

A device Reset forces the CMCON register to its Reset state, causing the comparator module to be in the Comparator Reset mode, $CM\langle 2:0 \rangle = 000$. This ensures that all potential inputs are analog inputs. Device current is minimized when analog inputs are present at Reset time. The comparators will be powered down during the Reset interval.

20.9 Analog Input Connection Considerations

A simplified circuit for an analog input is shown in Figure 20-4. Since the analog pins are connected to a digital output, they have reverse biased diodes to V_{DD} and V_{SS} . The analog input, therefore, must be between V_{SS} and V_{DD} . If the input voltage deviates from this range by more than 0.6V in either direction, one of the diodes is forward biased and a latch-up condition may occur. A maximum source impedance of 10 k Ω is recommended for the analog sources. Any external component connected to an analog input pin, such as a capacitor or a Zener diode, should have very little leakage current.

FIGURE 20-4: COMPARATOR ANALOG INPUT MODEL

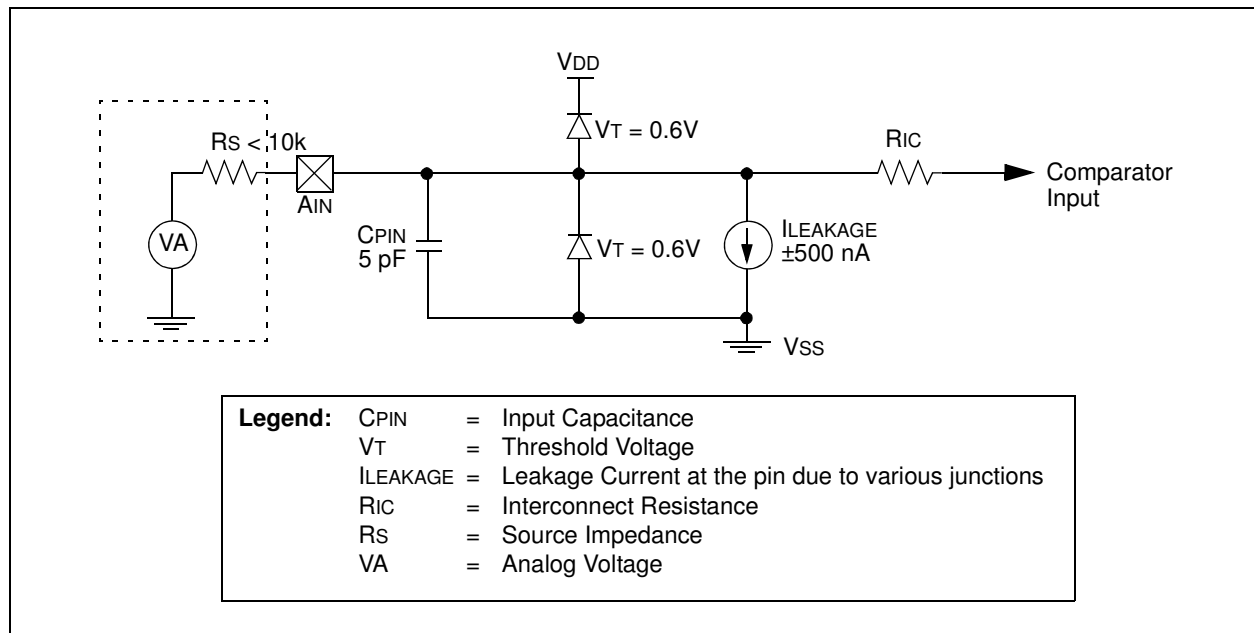

PIC18F6520/8520/6620/8620/6720/8720

TABLE 20-1: REGISTERS ASSOCIATED WITH COMPARATOR MODULE

Name	Bit 7	Bit 6	Bit 5	Bit 4	Bit 3	Bit 2	Bit 1	Bit 0	Value on POR	Value on all other Resets
CMCON	C2OUT	C1OUT	C2INV	C1INV	CIS	CM2	CM1	CM0	0000 0000	0000 0000
CVRCON	CVREN	CVROE	CVRR	CVRSS	CVR3	CVR2	CVR1	CVR0	0000 0000	0000 0000
INTCON	GIE/ GIEH	PEIE/ GIEL	TMR0IE	INT0IE	RBIE	TMR0IF	INT0IF	RBIF	0000 0000	0000 0000
PIR2	—	CMIF	—	—	BCLIF	LVDIF	TMR3IF	CCP2IF	-0-- 0000	-0-- 0000
PIE2	—	CMIE	—	—	BCLIE	LVDIE	TMR3IE	CCP2IE	-0-- 0000	-0-- 0000
IPR2	—	CMIP	—	—	BCLIP	LVDIP	TMR3IP	CCP2IP	-1-- 1111	-1-- 1111
PORTF	RF7	RF6	RF5	RF4	RF3	RF2	RF1	RF0	x000 0000	u000 0000
LATF	LATF7	LATF6	LATF5	LATF4	LATF3	LATF2	LATF1	LATF0	xxxx xxxx	uuuu uuuu
TRISF	TRISF7	TRISF6	TRISF5	TRISF4	TRISF3	TRISF2	TRISF1	TRISF0	1111 1111	1111 1111

Legend: x = unknown, u = unchanged, — = unimplemented, read as '0'.
Shaded cells are unused by the comparator module.

PIC18F6520/8520/6620/8620/6720/8720

21.0 COMPARATOR VOLTAGE REFERENCE MODULE

The comparator voltage reference is a 16-tap resistor ladder network that provides a selectable voltage reference. The resistor ladder is segmented to provide two ranges of CVREF values and has a power-down function to conserve power when the reference is not being used. The CVRCON register controls the operation of the reference as shown in Register 21-1. The block diagram is given in Figure 21-1.

The comparator reference supply voltage can come from either VDD or VSS, or the external VREF+ and VREF- that are multiplexed with RA3 and RA2. The comparator reference supply voltage is controlled by the CVRSS bit.

Note: In order to select external VREF+ and VREF- supply voltages, the Voltage Reference Configuration bits (VCFG1:VCFG0) of the ADCON1 register must be set appropriately.

21.1 Configuring the Comparator Voltage Reference

The comparator voltage reference can output 16 distinct voltage levels for each range. The equations used to calculate the output of the comparator voltage reference are as follows:

$$\text{If CVRR} = 1: \\ \text{CVREF} = (\text{CVR}\langle 3:0 \rangle / 24) \times \text{CVRSRC}$$

$$\text{If CVRR} = 0: \\ \text{CVREF} = (\text{CVRSRC} \times 1/4) + (\text{CVR}\langle 3:0 \rangle / 32) \times \text{CVRSRC}$$

The settling time of the comparator voltage reference must be considered when changing the CVREF output (**Section 26.0 “Electrical Characteristics”**).

REGISTER 21-1: CVRCON REGISTER

R/W-0	R/W-0	R/W-0	R/W-0	R/W-0	R/W-0	R/W-0	R/W-0
CVREN	CVROE	CVRR	CVRSS	CVR3	CVR2	CVR1	CVR0

bit 7

bit 0

bit 7 **CVREN:** Comparator Voltage Reference Enable bit

1 = CVREF circuit powered on
0 = CVREF circuit powered down

bit 6 **CVROE:** Comparator VREF Output Enable bit⁽¹⁾

1 = CVREF voltage level is also output on the RF5/AN10/CVREF pin
0 = CVREF voltage is disconnected from the RF5/AN10/CVREF pin

bit 5 **CVRR:** Comparator VREF Range Selection bit

1 = 0.00 CVRSRC to 0.667 CVRSRC, with CVRSRC/24 step size (low range)
0 = 0.25 CVRSRC to 0.75 CVRSRC, with CVRSRC/32 step size (high range)

bit 4 **CVRSS:** Comparator VREF Source Selection bit⁽²⁾

1 = Comparator reference source CVRSRC = VREF+ – VREF-
0 = Comparator reference source CVRSRC = VDD – VSS

bit 3-0 **CVR3:CVRO:** Comparator VREF Value Selection bits ($0 \leq \text{VR3:VR0} \leq 15$)

When CVRR = 1:
 $\text{CVREF} = (\text{CVR}\langle 3:0 \rangle / 24) \cdot (\text{CVRSRC})$

When CVRR = 0:
 $\text{CVREF} = 1/4 \cdot (\text{CVRSRC}) + (\text{CVR3:CVRO} / 32) \cdot (\text{CVRSRC})$

Note 1: If enabled for output, RF5 must also be configured as an input by setting TRISF<5> to ‘1’.

2: In order to select external VREF+ and VREF- supply voltages, the Voltage Reference Configuration bits (VCFG1:VCFG0) of the ADCON1 register must be set appropriately.

Legend:

R = Readable bit	W = Writable bit	U = Unimplemented bit, read as ‘0’
- n = Value at POR	‘1’ = Bit is set	‘0’ = Bit is cleared x = Bit is unknown

PIC18F6520/8520/6620/8620/6720/8720

FIGURE 21-1: VOLTAGE REFERENCE BLOCK DIAGRAM

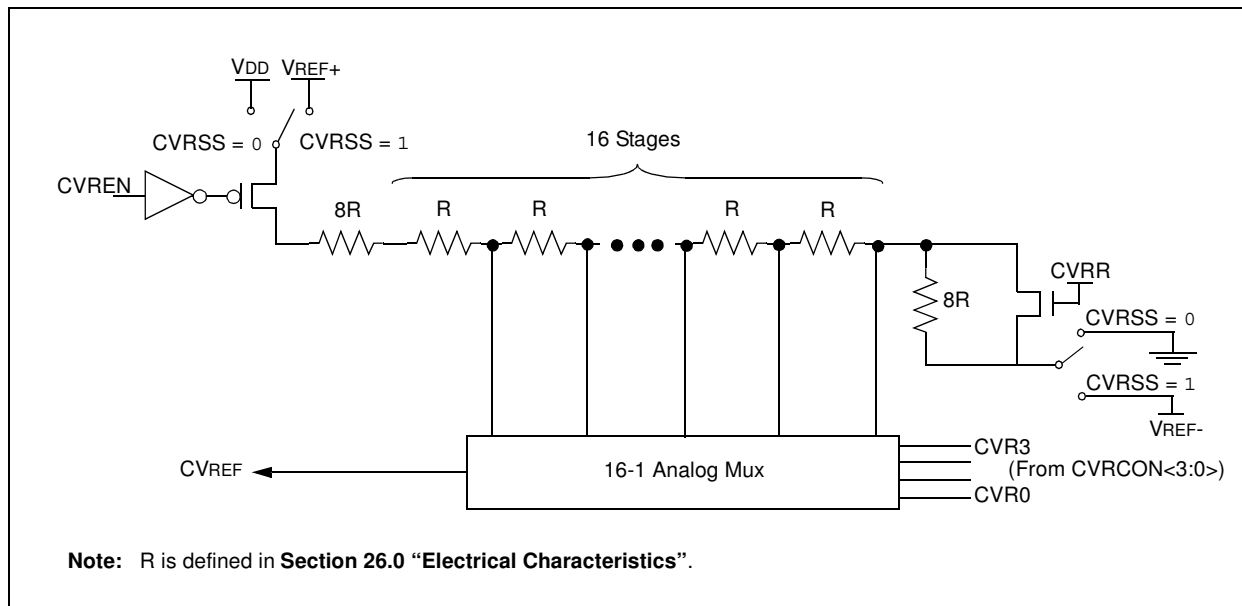

21.2 Voltage Reference Accuracy/Error

The full range of voltage reference cannot be realized due to the construction of the module. The transistors on the top and bottom of the resistor ladder network (Figure 21-1) keep CVREF from approaching the reference source rails. The voltage reference is derived from the reference source; therefore, the CVREF output changes with fluctuations in that source. The tested absolute accuracy of the voltage reference can be found in Section 26.0 "Electrical Characteristics".

21.3 Operation During Sleep

When the device wakes up from Sleep through an interrupt or a Watchdog Timer time-out, the contents of the CVRCON register are not affected. To minimize current consumption in Sleep mode, the voltage reference should be disabled.

21.4 Effects of a Reset

A device Reset disables the voltage reference by clearing bit CVREN (CVRCON<7>). This Reset also disconnects the reference from the RA2 pin by clearing bit CVROE (CVRCON<6>) and selects the high-voltage range by clearing bit CVRR (CVRCON<5>). The VRSS value select bits, CVRCON<3:0>, are also cleared.

21.5 Connection Considerations

The voltage reference module operates independently of the comparator module. The output of the reference generator may be connected to the RF5 pin if the TRISF<5> bit is set and the CVROE bit is set. Enabling the voltage reference output onto the RF5 pin, configured as a digital input, will increase current consumption. Connecting RF5 as a digital output with VRSS enabled will also increase current consumption.

The RF5 pin can be used as a simple D/A output with limited drive capability. Due to the limited current drive capability, a buffer must be used on the voltage reference output for external connections to VREF. Figure 21-2 shows an example buffering technique.

PIC18F6520/8520/6620/8620/6720/8720

FIGURE 21-2: VOLTAGE REFERENCE OUTPUT BUFFER EXAMPLE

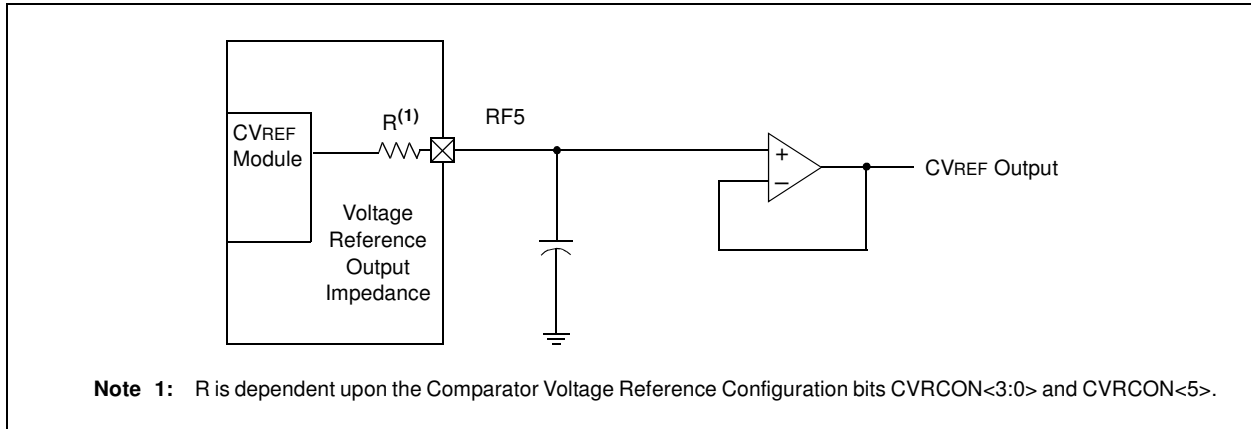

TABLE 21-1: REGISTERS ASSOCIATED WITH COMPARATOR VOLTAGE REFERENCE

Name	Bit 7	Bit 6	Bit 5	Bit 4	Bit 3	Bit 2	Bit 1	Bit 0	Value on POR	Value on all other Resets
CVRCON	CVREN	CVROE	CVRR	CVRSS	CVR3	CVR2	CVR1	CVR0	0000 0000	0000 0000
CMCON	C2OUT	C1OUT	C2INV	C1INV	CIS	CM2	CM1	CM0	0000 0000	0000 0000
TRISF	TRISF7	TRISF6	TRISF5	TRISF4	TRISF3	TRISF2	TRISF1	TRISF0	1111 1111	1111 1111

Legend: x = unknown, u = unchanged, – = unimplemented, read as '0'.
Shaded cells are not used with the comparator voltage reference.

PIC18F6520/8520/6620/8620/6720/8720

NOTES:

22.0 LOW-VOLTAGE DETECT

In many applications, the ability to determine if the device voltage (V_{DD}) is below a specified voltage level is a desirable feature. A window of operation for the application can be created, where the application software can do “housekeeping tasks” before the device voltage exits the valid operating range. This can be done using the Low-Voltage Detect module.

This module is a software programmable circuitry, where a device voltage trip point can be specified. When the voltage of the device becomes lower than the specified point, an interrupt flag is set. If the interrupt is enabled, the program execution will branch to the interrupt vector address and the software can then respond to that interrupt source.

The Low-Voltage Detect circuitry is completely under software control. This allows the circuitry to be “turned off” by the software, which minimizes the current consumption for the device.

Figure 22-1 shows a possible application voltage curve (typically for batteries). Over time, the device voltage decreases. When the device voltage equals voltage V_A , the LVD logic generates an interrupt. This occurs at time T_A . The application software then has the time, until the device voltage is no longer in valid operating range, to shut down the system. Voltage point V_B is the minimum valid operating voltage specification. This occurs at time T_B . The difference $T_B - T_A$ is the total time for shutdown.

FIGURE 22-1: TYPICAL LOW-VOLTAGE DETECT APPLICATION

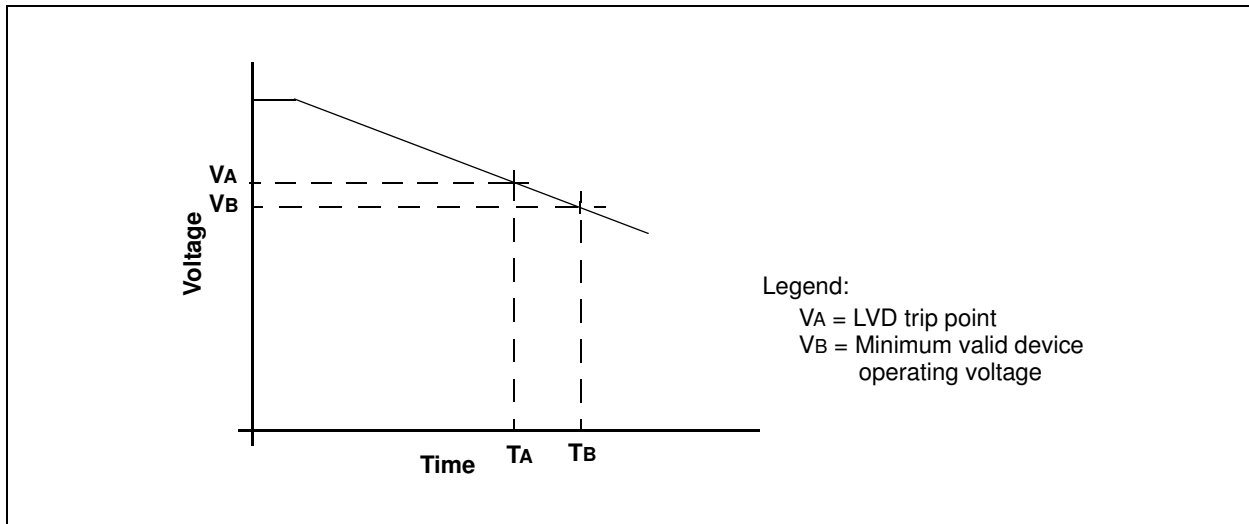

The block diagram for the LVD module is shown in Figure 22-2. A comparator uses an internally generated reference voltage as the set point. When the selected tap output of the device voltage crosses the set point (is lower than), the LVDIF bit is set.

Each node in the resistor divider represents a “trip point” voltage. The “trip point” voltage is the minimum supply voltage level at which the device can operate before the LVD module asserts an interrupt. When the

supply voltage is equal to the trip point, the voltage tapped off of the resistor array is equal to the 1.2V internal reference voltage generated by the voltage reference module. The comparator then generates an interrupt signal, setting the LVDIF bit. This voltage is software programmable to any one of 16 values (see Figure 22-2). The trip point is selected by programming the LVDL3:LVDL0 bits (LVDCON<3:0>).

PIC18F6520/8520/6620/8620/6720/8720

FIGURE 22-2: LOW-VOLTAGE DETECT (LVD) BLOCK DIAGRAM

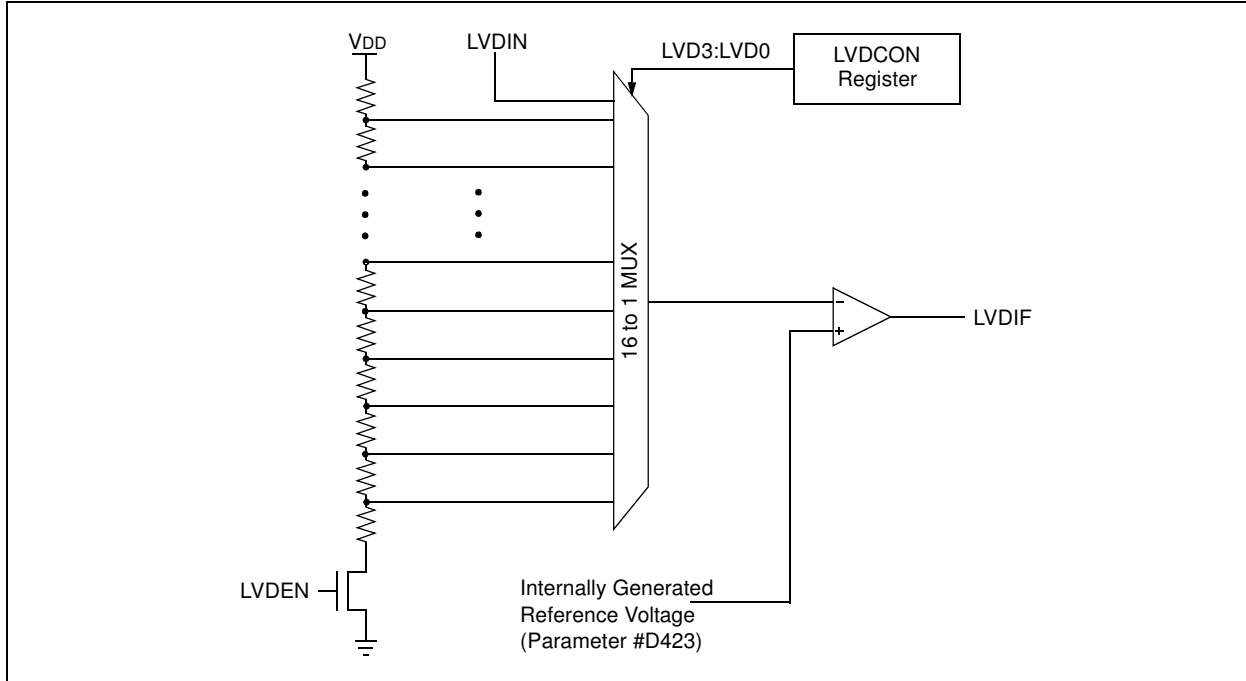

The LVD module has an additional feature that allows the user to supply the trip voltage to the module from an external source. This mode is enabled when bits LVDL3:LVDL0 are set to '1111'. In this state, the comparator input is multiplexed from the external input pin,

LVDIN (Figure 22-3). This gives users flexibility because it allows them to configure the Low-Voltage Detect interrupt to occur at any voltage in the valid operating range.

FIGURE 22-3: LOW-VOLTAGE DETECT (LVD) WITH EXTERNAL INPUT BLOCK DIAGRAM

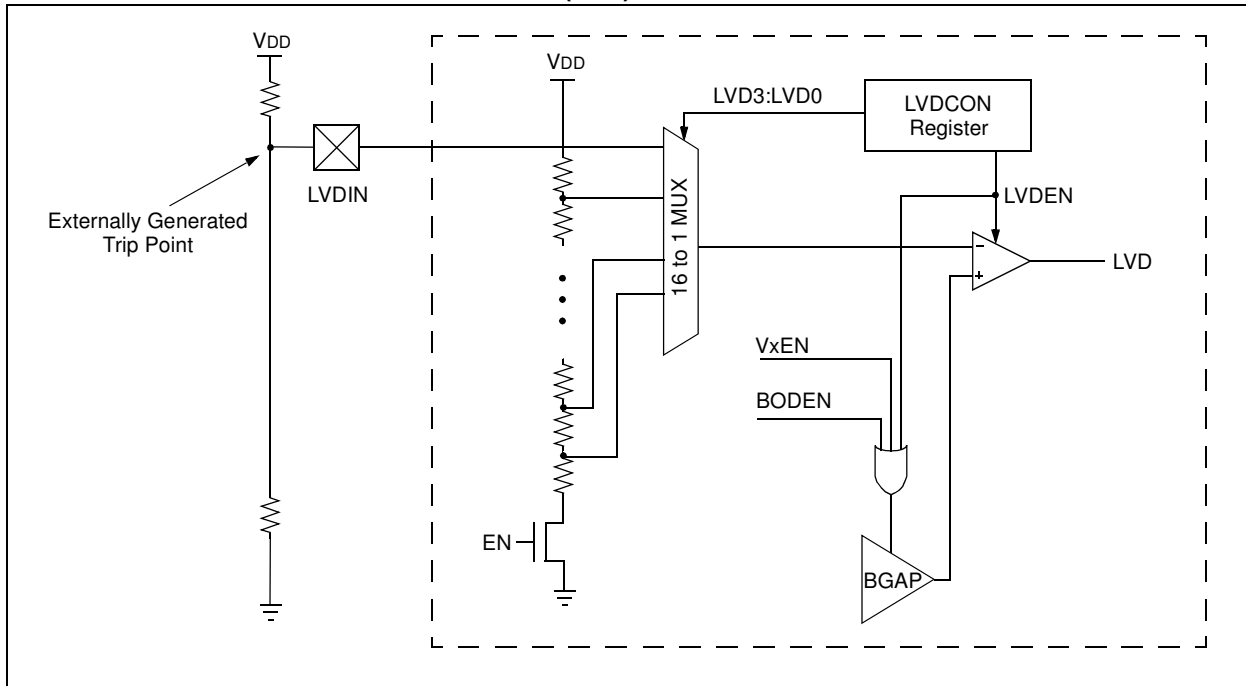

PIC18F6520/8520/6620/8620/6720/8720

22.1 Control Register

The Low-Voltage Detect Control register controls the operation of the Low-Voltage Detect circuitry.

REGISTER 22-1: LVDCON REGISTER

U-0	U-0	R-0	R/W-0	R/W-0	R/W-1	R/W-0	R/W-1	
—	—	IRVST	LV DEN	LV DL3	LV DL2	LV DL1	LV DL0	
bit 7								bit 0

bit 7-6 **Unimplemented:** Read as '0'

bit 5 **IRVST:** Internal Reference Voltage Stable Flag bit

1 = Indicates that the Low-Voltage Detect logic will generate the interrupt flag at the specified voltage range

0 = Indicates that the Low-Voltage Detect logic will not generate the interrupt flag at the specified voltage range and the LVD interrupt should not be enabled

bit 4 **LV DEN:** Low-Voltage Detect Power Enable bit

1 = Enables LVD, powers up LVD circuit

0 = Disables LVD, powers down LVD circuit

bit 3-0 **LV DL3:LV DL0:** Low-Voltage Detection Limit bits⁽²⁾

1111 = External analog input is used (input comes from the LVDIN pin)

1110 = 4.64V

1101 = 4.33V

1100 = 4.13V

1011 = 3.92V

1010 = 3.72V

1001 = 3.61V

1000 = 3.41V

0111 = 3.1V

0110 = 2.89V

0101 = 2.78V

0100 = 2.58V

0011 = 2.47V

0010 = 2.27V

0001 = 2.06V

0000 = Reserved

Note 1: LV DL3:LV DL0 modes which result in a trip point below the valid operating voltage of the device are not tested.

2: Typical values shown, see parameter D420 in Table 26-3 for more information.

Legend:

R = Readable bit

W = Writable bit

U = Unimplemented bit, read as '0'

- n = Value at POR

'1' = Bit is set

'0' = Bit is cleared

x = Bit is unknown

PIC18F6520/8520/6620/8620/6720/8720

22.2 Operation

Depending on the power source for the device voltage, the voltage normally decreases relatively slowly. This means that the LVD module does not need to be constantly operating. To decrease the current requirements, the LVD circuitry only needs to be enabled for short periods, where the voltage is checked. After doing the check, the LVD module may be disabled.

Each time that the LVD module is enabled, the circuitry requires some time to stabilize. After the circuitry has stabilized, all status flags may be cleared. The module will then indicate the proper state of the system.

The following steps are needed to set up the LVD module:

1. Write the value to the LVDL3:LVDL0 bits (LVDCON register), which selects the desired LVD trip point.
2. Ensure that LVD interrupts are disabled (the LVDIE bit is cleared or the GIE bit is cleared).
3. Enable the LVD module (set the LVDEN bit in the LVDCON register).
4. Wait for the LVD module to stabilize (the IRVST bit to become set).
5. Clear the LVD interrupt flag, which may have falsely become set, until the LVD module has stabilized (clear the LVDIF bit).
6. Enable the LVD interrupt (set the LVDIE and the GIE bits).

Figure 22-4 shows typical waveforms that the LVD module may be used to detect.

FIGURE 22-4: LOW-VOLTAGE DETECT WAVEFORMS

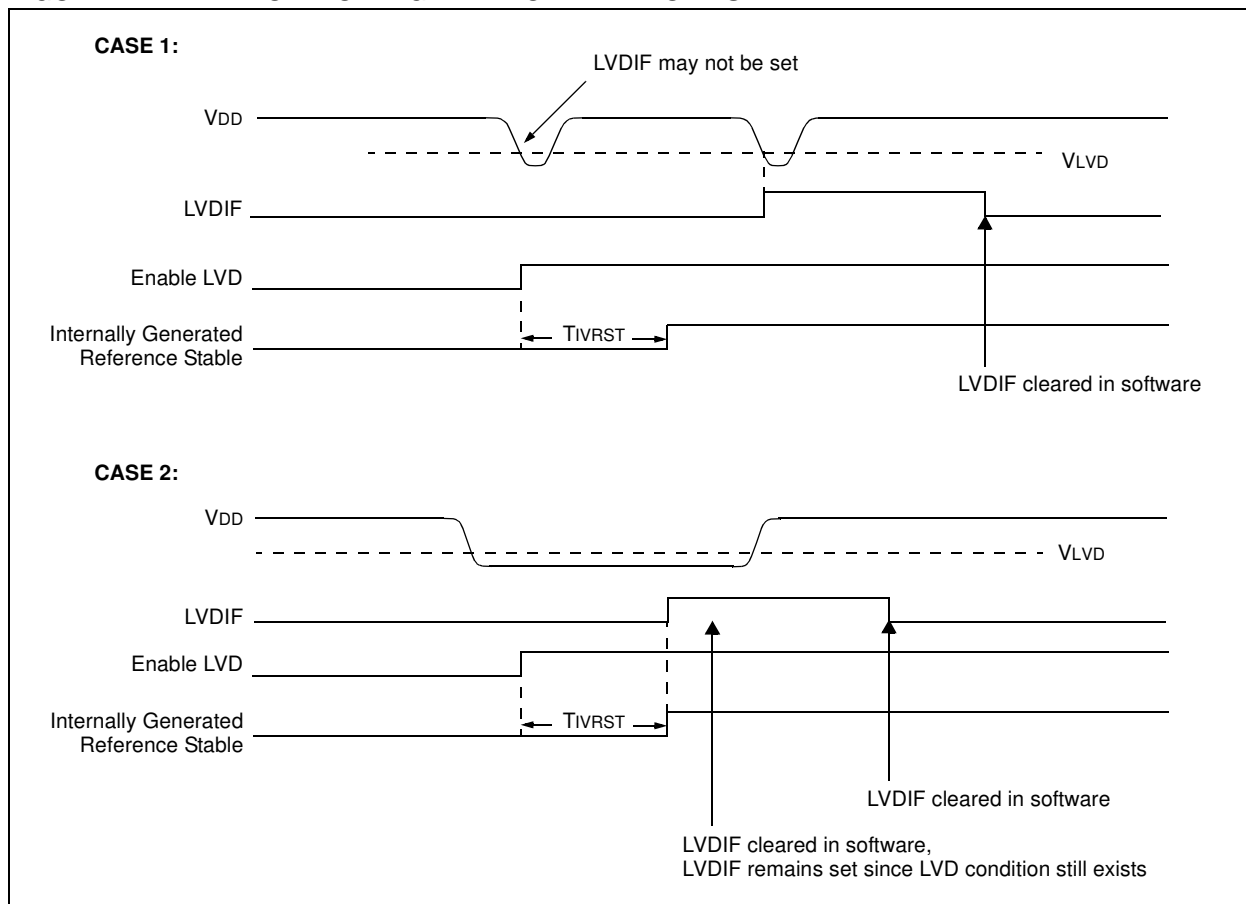

PIC18F6520/8520/6620/8620/6720/8720

22.2.1 REFERENCE VOLTAGE SET POINT

The internal reference voltage of the LVD module, specified in electrical specification parameter #D423, may be used by other internal circuitry (the Programmable Brown-out Reset). If these circuits are disabled (lower current consumption), the reference voltage circuit requires a time to become stable before a low-voltage condition can be reliably detected. This time is invariant of system clock speed. This start-up time is specified in electrical specification parameter #36. The low-voltage interrupt flag will not be enabled until a stable reference voltage is reached. Refer to the waveform in Figure 22-4.

22.2.2 CURRENT CONSUMPTION

When the module is enabled, the LVD comparator and voltage divider are enabled and will consume static current. The voltage divider can be tapped from multiple places in the resistor array. Total current consumption, when enabled, is specified in electrical specification parameter #D022B.

22.3 Operation During Sleep

When enabled, the LVD circuitry continues to operate during Sleep. If the device voltage crosses the trip point, the LVDIF bit will be set and the device will wake-up from Sleep. Device execution will continue from the interrupt vector address if interrupts have been globally enabled.

22.4 Effects of a Reset

A device Reset forces all registers to their Reset state. This forces the LVD module to be turned off.

PIC18F6520/8520/6620/8620/6720/8720

NOTES:

23.0 SPECIAL FEATURES OF THE CPU

There are several features intended to maximize system reliability, minimize cost through elimination of external components, provide power saving operating modes and offer code protection. These are:

- Oscillator Selection
- Reset
 - Power-on Reset (POR)
 - Power-up Timer (PWRT)
 - Oscillator Start-up Timer (OST)
 - Brown-out Reset (BOR)
- Interrupts
- Watchdog Timer (WDT)
- Sleep
- Code Protection
- ID Locations
- In-Circuit Serial Programming

All PIC18FXX20 devices have a Watchdog Timer, which is permanently enabled via the configuration bits, or software controlled. It runs off its own RC oscillator for added reliability. There are two timers that offer necessary delays on power-up. One is the Oscillator Start-up Timer (OST), intended to keep the chip in Reset until the crystal oscillator is stable. The other is the Power-up Timer (PWRT), which provides a fixed delay on power-up only, designed to keep the part in Reset while the power supply stabilizes. With these two timers on-chip, most applications need no external Reset circuitry.

Sleep mode is designed to offer a very low current power-down mode. The user can wake-up from Sleep through external Reset, Watchdog Timer Wake-up or through an interrupt. Several oscillator options are also made available to allow the part to fit the application. The RC oscillator option saves system cost, while the LP crystal option saves power. A set of configuration bits is used to select various options.

23.1 Configuration Bits

The configuration bits can be programmed (read as '0'), or left unprogrammed (read as '1'), to select various device configurations. These bits are mapped, starting at program memory location 300000h.

The user will note that address 300000h is beyond the user program memory space. In fact, it belongs to the configuration memory space (300000h through 3FFFFFFh), which can only be accessed using table reads and table writes.

Programming the configuration registers is done in a manner similar to programming the Flash memory. The EECON1 register WR bit starts a self-timed write to the configuration register. In normal operation mode, a TBLWT instruction with the TBLPTR pointed to the configuration register sets up the address and the data for the configuration register write. Setting the WR bit starts a long write to the configuration register. The configuration registers are written a byte at a time. To write or erase a configuration cell, a TBLWT instruction can write a '1' or a '0' into the cell.

PIC18F6520/8520/6620/8620/6720/8720

TABLE 23-1: CONFIGURATION BITS AND DEVICE IDS

File Name	Bit 7	Bit 6	Bit 5	Bit 4	Bit 3	Bit 2	Bit 1	Bit 0	Default/ Unprogrammed Value
300001h CONFIG1H	—	—	OSCSEN	—	—	FOSC2	FOSC1	FOSC0	--1- -111
300002h CONFIG2L	—	—	—	—	BORV1	BORV0	BODEN	PWRTEN	---- 1111
300003h CONFIG2H	—	—	—	—	WDTPS2	WDTPS1	WDTPS0	WDTEN	---- 1111
300004h ⁽¹⁾ CONFIG3L	WAIT	—	—	—	—	—	PM1	PM0	1--- --11
300005h CONFIG3H	—	—	—	—	—	—	r ⁽³⁾	CCP2MX	---- --11
300006h CONFIG4L	DEBUG	—	—	—	—	LVP	—	STVREN	1--- -1-1
300008h CONFIG5L	CP7 ⁽²⁾	CP6 ⁽²⁾	CP5 ⁽²⁾	CP4 ⁽²⁾	CP3	CP2	CP1	CP0	1111 1111
300009h CONFIG5H	CPD	CPB	—	—	—	—	—	—	11-- ----
30000Ah CONFIG6L	WRT7 ⁽²⁾	WRT6 ⁽²⁾	WRT5 ⁽²⁾	WRT4 ⁽²⁾	WRT3	WRT2	WRT1	WRT0	1111 1111
30000Bh CONFIG6H	WRTD	WRTB	WRTC	—	—	—	—	—	111- ----
30000Ch CONFIG7L	EBTR7 ⁽²⁾	EBTR6 ⁽²⁾	EBTR5 ⁽²⁾	EBTR4 ⁽²⁾	EBTR3	EBTR2	EBTR1	EBTR0	1111 1111
30000Dh CONFIG7H	—	EBTRB	—	—	—	—	—	—	-1-- ----
3FFFFEh DEVID1	DEV2	DEV1	DEV0	REV4	REV3	REV2	REV1	REV0	(4)
3FFFFFh DEVID2	DEV10	DEV9	DEV8	DEV7	DEV6	DEV5	DEV4	DEV3	0000 0110

Legend: x = unknown, u = unchanged, — = unimplemented, q = value depends on condition, r = reserved.
Shaded cells are unimplemented, read as '0'.

- Note 1:** Unimplemented in PIC18F6X20 devices; maintain this bit set.
2: Unimplemented in PIC18FX520 and PIC18FX620 devices; maintain this bit set.
3: Unimplemented in PIC18FX620 and PIC18FX720 devices; maintain this bit set.
4: See Register 23-13 for DEVID1 values.

REGISTER 23-1: CONFIG1H: CONFIGURATION REGISTER 1 HIGH (BYTE ADDRESS 300001h)

U-0	U-0	R/P-1	U-0	U-0	R/P-1	R/P-1	R/P-1	
—	—	OSCSEN	—	—	FOSC2	FOSC1	FOSC0	
bit 7								bit 0

bit 7-6 **Unimplemented:** Read as '0'

bit 5 **OSCSEN:** Oscillator System Clock Switch Enable bit
 1 = Oscillator system clock switch option is disabled (main oscillator is source)
 0 = Timer1 Oscillator system clock switch option is enabled (oscillator switching is enabled)

bit 4-3 **Unimplemented:** Read as '0'

bit 2-0 **FOSC2:FOSC0:** Oscillator Selection bits
 111 = RC oscillator w/ OSC2 configured as RA6
 110 = HS oscillator with PLL enabled; clock frequency = (4 x FOSC)
 101 = EC oscillator w/ OSC2 configured as RA6
 100 = EC oscillator w/ OSC2 configured as divide-by-4 clock output
 011 = RC oscillator w/ OSC2 configured as divide-by-4 clock output
 010 = HS oscillator
 001 = XT oscillator
 000 = LP oscillator

Legend:
 R = Readable bit P = Programmable bit U = Unimplemented bit, read as '0'
 - n = Value when device is unprogrammed u = Unchanged from programmed state

PIC18F6520/8520/6620/8620/6720/8720

REGISTER 23-2: CONFIG2L: CONFIGURATION REGISTER 2 LOW (BYTE ADDRESS 300002h)

U-0	U-0	U-0	U-0	R/P-1	R/P-1	R/P-1	R/P-1
—	—	—	—	BORV1	BORV0	BOREN	PWRTEN
bit 7				bit 0			

bit 7-4 **Unimplemented:** Read as '0'

bit 3-2 **BORV1:BORV0:** Brown-out Reset Voltage bits

11 = VBOR set to 2.5V
 10 = VBOR set to 2.7V
 01 = VBOR set to 4.2V
 00 = VBOR set to 4.5V

bit 1 **BOREN:** Brown-out Reset Enable bit

1 = Brown-out Reset enabled
 0 = Brown-out Reset disabled

bit 0 **PWRTEN:** Power-up Timer Enable bit

1 = PWRT disabled
 0 = PWRT enabled

Legend:

R = Readable bit P = Programmable bit U = Unimplemented bit, read as '0'
 - n = Value when device is unprogrammed u = Unchanged from programmed state

REGISTER 23-3: CONFIG2H: CONFIGURATION REGISTER 2 HIGH (BYTE ADDRESS 300003h)

U-0	U-0	U-0	U-0	R/P-1	R/P-1	R/P-1	R/P-1
—	—	—	—	WDTPS2	WDTPS1	WDTPS0	WDTEN
bit 7				bit 0			

bit 7-4 **Unimplemented:** Read as '0'

bit 3-1 **WDTPS2:WDTPS0:** Watchdog Timer Postscale Select bits

111 = 1:128
 110 = 1:64
 101 = 1:32
 100 = 1:16
 011 = 1:8
 010 = 1:4
 001 = 1:2
 000 = 1:1

bit 0 **WDTEN:** Watchdog Timer Enable bit

1 = WDT enabled
 0 = WDT disabled (control is placed on the SWDTEN bit)

Legend:

R = Readable bit P = Programmable bit U = Unimplemented bit, read as '0'
 - n = Value when device is unprogrammed u = Unchanged from programmed state

PIC18F6520/8520/6620/8620/6720/8720

REGISTER 23-4: CONFIG3L: CONFIGURATION REGISTER 3 LOW (BYTE ADDRESS 300004h)⁽¹⁾

R/P-1	U-0	U-0	U-0	U-0	U-0	R/P-1	R/P-1	
WAIT	—	—	—	—	—	PM1	PM0	
bit 7							bit 0	

- bit 7 **WAIT:** External Bus Data Wait Enable bit
 1 = Wait selections unavailable for table reads and table writes
 0 = Wait selections for table reads and table writes are determined by the WAIT1:WAIT0 bits (MEMCOM<5:4>)
- bit 6-2 **Unimplemented:** Read as '0'
- bit 1-0 **PM1:PM0:** Processor Mode Select bits
 11 = Microcontroller mode
 10 = Microprocessor mode
 01 = Microprocessor with Boot Block mode
 00 = Extended Microcontroller mode

Note 1: This register is unimplemented in PIC18F6X20 devices; maintain these bits set.

Legend:

R = Readable bit P = Programmable bit U = Unimplemented bit, read as '0'
 - n = Value when device is unprogrammed u = Unchanged from programmed state

REGISTER 23-5: CONFIG3H: CONFIGURATION REGISTER 3 HIGH (BYTE ADDRESS 300005h)

U-0	U-0	U-0	U-0	U-0	U-0	R/P-1	R/P-1	
—	—	—	—	—	—	r ⁽¹⁾	CCP2MX	
bit 7							bit 0	

- bit 7-2 **Unimplemented:** Read as '0'
- bit 1 **Reserved:** Read as unknown⁽¹⁾
- bit 0 **CCP2MX:** CCP2 Mux bit
In Microcontroller mode:
 1 = CCP2 input/output is multiplexed with RC1
 0 = CCP2 input/output is multiplexed with RE7
In Microprocessor, Microprocessor with Boot Block and Extended Microcontroller modes (PIC18F8X20 devices only):
 1 = CCP2 input/output is multiplexed with RC1
 0 = CCP2 input/output is multiplexed with RB3

Note 1: Unimplemented in PIC18FX620 and PIC18FX720 devices; read as '0'.

Legend:

R = Readable bit P = Programmable bit U = Unimplemented bit, read as '0'
 - n = Value when device is unprogrammed u = Unchanged from programmed state

PIC18F6520/8520/6620/8620/6720/8720

REGISTER 23-6: CONFIG4L: CONFIGURATION REGISTER 4 LOW (BYTE ADDRESS 300006h)

R/P-1	U-0	U-0	U-0	U-0	R/P-1	U-0	R/P-1
$\overline{\text{DEBUG}}$	—	—	—	—	LVP	—	STVREN
bit 7							bit 0

bit 7 **DEBUG:** Background Debugger Enable bit

1 = Background debugger disabled. RB6 and RB7 configured as general purpose I/O pins.
0 = Background debugger enabled. RB6 and RB7 are dedicated to In-Circuit Debug.

bit 6-3 **Unimplemented:** Read as '0'

bit 2 **LVP:** Low-Voltage ICSP Enable bit

1 = Low-voltage ICSP enabled
0 = Low-voltage ICSP disabled

bit 1 **Unimplemented:** Read as '0'

bit 0 **STVREN:** Stack Full/Underflow Reset Enable bit

1 = Stack full/underflow will cause Reset
0 = Stack full/underflow will not cause Reset

Legend:

R = Readable bit P = Programmable bit U = Unimplemented bit, read as '0'
- n = Value when device is unprogrammed u = Unchanged from programmed state

PIC18F6520/8520/6620/8620/6720/8720

REGISTER 23-7: CONFIG5L: CONFIGURATION REGISTER 5 LOW (BYTE ADDRESS 300008h)

R/P-1	R/P-1	R/P-1	R/P-1	R/P-1	R/P-1	R/P-1	R/P-1
CP7 ⁽¹⁾	CP6 ⁽¹⁾	CP5 ⁽¹⁾	CP4 ⁽¹⁾	CP3	CP2	CP1	CP0
bit 7				bit 0			

- bit 7 **CP7:** Code Protection bit⁽¹⁾
 1 = Block 7 (01C000-01FFFFh) not code-protected
 0 = Block 7 (01C000-01FFFFh) code-protected
- bit 6 **CP6:** Code Protection bit⁽¹⁾
 1 = Block 6 (018000-01BFFFh) not code-protected
 0 = Block 6 (018000-01BFFFh) code-protected
- bit 5 **CP5:** Code Protection bit⁽¹⁾
 1 = Block 5 (014000-017FFFh) not code-protected
 0 = Block 5 (014000-017FFFh) code-protected
- bit 4 **CP4:** Code Protection bit⁽¹⁾
 1 = Block 4 (010000-013FFFh) not code-protected
 0 = Block 4 (010000-013FFFh) code-protected
- bit 3 **CP3:** Code Protection bit
For PIC18FX520 devices:
 1 = Block 3 (006000-007FFFh) not code-protected
 0 = Block 3 (006000-007FFFh) code-protected
For PIC18FX620 and PIC18FX720 devices:
 1 = Block 3 (00C000-00FFFFh) not code-protected
 0 = Block 3 (00C000-00FFFFh) code-protected
- bit 2 **CP2:** Code Protection bit
For PIC18FX520 devices:
 1 = Block 2 (004000-005FFFh) not code-protected
 0 = Block 2 (004000-005FFFh) code-protected
For PIC18FX620 and PIC18FX720 devices:
 1 = Block 2 (008000-00BFFFh) not code-protected
 0 = Block 2 (008000-00BFFFh) code-protected
- bit 1 **CP1:** Code Protection bit
For PIC18FX520 devices:
 1 = Block 1 (002000-003FFFh) not code-protected
 0 = Block 1 (002000-003FFFh) code-protected
For PIC18FX620 and PIC18FX720 devices:
 1 = Block 1 (004000-007FFFh) not code-protected
 0 = Block 1 (004000-007FFFh) code-protected
- bit 0 **CP0:** Code Protection bit
For PIC18FX520 devices:
 1 = Block 0 (000800-001FFFh) not code-protected
 0 = Block 0 (000800-001FFFh) code-protected
For PIC18FX620 and PIC18FX720 devices:
 1 = Block 0 (000200-003FFFh) not code-protected
 0 = Block 0 (000200-003FFFh) code-protected

Note 1: Unimplemented in PIC18FX520 and PIC18FX620 devices; maintain this bit set.

Legend:

R = Readable bit	P = Programmable bit	U = Unimplemented bit, read as '0'
- n = Value when device is unprogrammed	u = Unchanged from programmed state	

PIC18F6520/8520/6620/8620/6720/8720

REGISTER 23-8: CONFIG5H: CONFIGURATION REGISTER 5 HIGH (BYTE ADDRESS 300009h)

R/C-1	R/C-1	U-0	U-0	U-0	U-0	U-0	U-0
CPD	CPB	—	—	—	—	—	—

bit 7 bit 0

bit 7 **CPD:** Data EEPROM Code Protection bit

1 = Data EEPROM not code-protected

0 = Data EEPROM code-protected

bit 6 **CPB:** Boot Block Code Protection bit

For PIC18FX520 devices:

1 = Boot Block (000000-0007FFh) not code-protected

0 = Boot Block (000000-0007FFh) code-protected

For PIC18FX620 and PIC18FX720 devices:

1 = Boot Block (000000-0001FFh) not code-protected

0 = Boot Block (000000-0001FFh) code-protected

bit 5-0 **Unimplemented:** Read as '0'

Legend:

R = Readable bit

C = Clearable bit

U = Unimplemented bit, read as '0'

- n = Value when device is unprogrammed

u = Unchanged from programmed state

PIC18F6520/8520/6620/8620/6720/8720

REGISTER 23-9: CONFIG6L: CONFIGURATION REGISTER 6 LOW (BYTE ADDRESS 3000Ah)

R/P-1	R/P-1	R/P-1	R/P-1	R/P-1	R/P-1	R/P-1	R/P-1	
WRT7 ⁽¹⁾	WRT6 ⁽¹⁾	WRT5 ⁽¹⁾	WRT4 ⁽¹⁾	WRT3	WRT2	WRT1	WRT0	
bit 7								bit 0

- bit 7 **WR7:** Write Protection bit⁽¹⁾
 1 = Block 7 (01C000-01FFFFh) not write-protected
 0 = Block 7 (01C000-01FFFFh) write-protected
- bit 6 **WR6:** Write Protection bit⁽¹⁾
 1 = Block 6 (018000-01BFFFh) not write-protected
 0 = Block 6 (018000-01BFFFh) write-protected
- bit 5 **WR5:** Write Protection bit⁽¹⁾
 1 = Block 5 (014000-017FFFh) not write-protected
 0 = Block 5 (014000-017FFFh) write-protected
- bit 4 **WR4:** Write Protection bit⁽¹⁾
 1 = Block 4 (010000-013FFFh) not write-protected
 0 = Block 4 (010000-013FFFh) write-protected
- bit 3 **WR3:** Write Protection bit
For PIC18FX520 devices:
 1 = Block 3 (006000-007FFFh) not write-protected
 0 = Block 3 (006000-007FFFh) write-protected
For PIC18FX620 and PIC18FX720 devices:
 1 = Block 3 (00C000-00FFFFh) not write-protected
 0 = Block 3 (00C000-00FFFFh) write-protected
- bit 2 **WR2:** Write Protection bit
For PIC18FX520 devices:
 1 = Block 2 (004000-005FFFh) not write-protected
 0 = Block 2 (004000-005FFFh) write-protected
For PIC18FX620 and PIC18FX720 devices:
 1 = Block 2 (008000-00BFFFh) not write-protected
 0 = Block 2 (008000-00BFFFh) write-protected
- bit 1 **WR1:** Write Protection bit
For PIC18FX520 devices:
 1 = Block 1 (002000-003FFFh) not write-protected
 0 = Block 1 (002000-003FFFh) write-protected
For PIC18FX620 and PIC18FX720 devices:
 1 = Block 1 (004000-007FFFh) not write-protected
 0 = Block 1 (004000-007FFFh) write-protected
- bit 0 **WR0:** Write Protection bit
For PIC18FX520 devices:
 1 = Block 0 (000800-001FFFh) not write-protected
 0 = Block 0 (000800-001FFFh) write-protected
For PIC18FX620 and PIC18FX720 devices:
 1 = Block 0 (000200-003FFFh) not write-protected
 0 = Block 0 (000200-003FFFh) write-protected

Note 1: Unimplemented in PIC18FX520 and PIC18FX620 devices; maintain this bit set.

Legend:

R = Readable bit P = Programmable bit U = Unimplemented bit, read as '0'
 - n = Value when device is unprogrammed u = Unchanged from programmed state

PIC18F6520/8520/6620/8620/6720/8720

REGISTER 23-10: CONFIG6H: CONFIGURATION REGISTER 6 HIGH (BYTE ADDRESS 30000Bh)

R/P-1	R/P-1	R-1	U-0	U-0	U-0	U-0	U-0
WRTD	WRTB	WRTC ⁽¹⁾	—	—	—	—	—

bit 7 bit 0

bit 7 **WRTD:** Data EEPROM Write Protection bit

1 = Data EEPROM not write-protected
0 = Data EEPROM write-protected

bit 6 **WRTB:** Boot Block Write Protection bit

For PIC18FX520 devices:

1 = Boot Block (000000-0007FFh) not write-protected
0 = Boot Block (000000-0007FFh) write-protected

For PIC18FX620 and PIC18FX720 devices:

1 = Boot Block (000000-0001FFh) not write-protected
0 = Boot Block (000000-0001FFh) write-protected

bit 5 **WRTC:** Configuration Register Write Protection bit⁽¹⁾

1 = Configuration registers (300000-3000FFh) not write-protected
0 = Configuration registers (300000-3000FFh) write-protected

Note 1: This bit is read-only and cannot be changed in user mode.

bit 4-0 **Unimplemented:** Read as '0'

Legend:

R = Readable bit P = Programmable bit U = Unimplemented bit, read as '0'
- n = Value when device is unprogrammed u = Unchanged from programmed state

PIC18F6520/8520/6620/8620/6720/8720

REGISTER 23-11: CONFIG7L: CONFIGURATION REGISTER 7 LOW (BYTE ADDRESS 3000Ch)

R/P-1	R/P-1	R/P-1	R/P-1	R/P-1	R/P-1	R/P-1	R/P-1	
EBTR7 ⁽¹⁾	EBTR6 ⁽¹⁾	EBTR5 ⁽¹⁾	EBTR4 ⁽¹⁾	EBTR3	EBTR2	EBTR1	EBTR0	
bit 7								bit 0

- bit 7 **EBTR7:** Table Read Protection bit⁽¹⁾
 1 = Block 3 (01C000-01FFFFh) not protected from table reads executed in other blocks
 0 = Block 3 (01C000-01FFFFh) protected from table reads executed in other blocks
- bit 6 **EBTR6:** Table Read Protection bit⁽¹⁾
 1 = Block 2 (018000-01BFFFh) not protected from table reads executed in other blocks
 0 = Block 2 (018000-01BFFFh) protected from table reads executed in other blocks
- bit 5 **EBTR5:** Table Read Protection bit⁽¹⁾
 1 = Block 1 (014000-017FFFh) not protected from table reads executed in other blocks
 0 = Block 1 (014000-017FFFh) protected from table reads executed in other blocks
- bit 4 **EBTR4:** Table Read Protection bit⁽¹⁾
 1 = Block 0 (010000-013FFFh) not protected from table reads executed in other blocks
 0 = Block 0 (010000-013FFFh) protected from table reads executed in other blocks
- bit 3 **EBTR3:** Table Read Protection bit
For PIC18FX520 devices:
 1 = Block 3 (006000-007FFFh) not protected from table reads executed in other blocks
 0 = Block 3 (006000-007FFFh) protected from table reads executed in other blocks
For PIC18FX620 and PIC18FX720 devices:
 1 = Block 3 (00C000-00FFFFh) not protected from table reads executed in other blocks
 0 = Block 3 (00C000-00FFFFh) protected from table reads executed in other blocks
- bit 2 **EBTR2:** Table Read Protection bit
For PIC18FX520 devices:
 1 = Block 2 (004000-005FFFh) not protected from table reads executed in other blocks
 0 = Block 2 (004000-005FFFh) protected from table reads executed in other blocks
For PIC18FX620 and PIC18FX720 devices:
 1 = Block 2 (008000-00BFFFh) not protected from table reads executed in other blocks
 0 = Block 2 (008000-00BFFFh) protected from table reads executed in other blocks
- bit 1 **EBTR1:** Table Read Protection bit
For PIC18FX520 devices:
 1 = Block 1 (002000-003FFFh) not protected from table reads executed in other blocks
 0 = Block 1 (002000-003FFFh) protected from table reads executed in other blocks
For PIC18FX620 and PIC18FX720 devices:
 1 = Block 1 (004000-007FFFh) not protected from table reads executed in other blocks
 0 = Block 1 (004000-007FFFh) protected from table reads executed in other blocks
- bit 0 **EBTR0:** Table Read Protection bit
For PIC18FX520 devices:
 1 = Block 0 (000800-001FFFh) not protected from table reads executed in other blocks
 0 = Block 0 (000800-001FFFh) protected from table reads executed in other blocks
For PIC18FX620 and PIC18FX720 devices:
 1 = Block 0 (000200-003FFFh) not protected from table reads executed in other blocks
 0 = Block 0 (000200-003FFFh) protected from table reads executed in other blocks

Note 1: Unimplemented in PIC18FX520 and PIC18FX620 devices; maintain this bit set.

Legend:

R = Readable bit P = Programmable bit U = Unimplemented bit, read as '0'
 - n = Value when device is unprogrammed u = Unchanged from programmed state

PIC18F6520/8520/6620/8620/6720/8720

REGISTER 23-12: CONFIG7H: CONFIGURATION REGISTER 7 HIGH (BYTE ADDRESS 3000Dh)

U-0	R/P-1	U-0	U-0	U-0	U-0	U-0	U-0	
—	EBTRB	—	—	—	—	—	—	
bit 7								bit 0

bit 7 **Unimplemented:** Read as '0'

bit 6 **EBTRB:** Boot Block Table Read Protection bit

For PIC18FX520 devices:

1 = Boot Block (000000-0007FFh) not protected from table reads executed in other blocks

0 = Boot Block (000000-0007FFh) protected from table reads executed in other blocks

For PIC18FX620 and PIC18FX720 devices:

1 = Boot Block (000000-0001FFh) not protected from table reads executed in other blocks

0 = Boot Block (000000-0001FFh) protected from table reads executed in other blocks

bit 5-0 **Unimplemented:** Read as '0'

Legend:

R = Readable bit P = Programmable bit U = Unimplemented bit, read as '0'
 - n = Value when device is unprogrammed u = Unchanged from programmed state

REGISTER 23-13: DEVICE ID REGISTER 1 FOR PIC18FXX20 DEVICES (ADDRESS 3FFFEh)

R	R	R	R	R	R	R	R	
DEV2	DEV1	DEV0	REV4	REV3	REV2	REV1	REV0	
bit 7								bit 0

bit 7-5 **DEV2:DEV0:** Device ID bits

000 = PIC18F8720

001 = PIC18F6720

010 = PIC18F8620

011 = PIC18F6620

bit 4-0 **REV4:REV0:** Revision ID bits

These bits are used to indicate the device revision.

Legend:

R = Readable bit P = Programmable bit U = Unimplemented bit, read as '0'
 - n = Value when device is unprogrammed u = Unchanged from programmed state

REGISTER 23-14: DEVICE ID REGISTER 2 FOR PIC18FXX20 DEVICES (ADDRESS 3FFFFh)

R	R	R	R	R	R	R	R	
DEV10	DEV9	DEV8	DEV7	DEV6	DEV5	DEV4	DEV3	
bit 7								bit 0

bit 7-0 **DEV10:DEV3:** Device ID bits

These bits are used with the DEV2:DEV0 bits in the Device ID Register 1 to identify the part number.

Legend:

R = Readable bit P = Programmable bit U = Unimplemented bit, read as '0'
 - n = Value when device is unprogrammed u = Unchanged from programmed state

PIC18F6520/8520/6620/8620/6720/8720

23.2 Watchdog Timer (WDT)

The Watchdog Timer is a free running, on-chip RC oscillator, which does not require any external components. This RC oscillator is separate from the RC oscillator of the OSC1/CLKI pin. That means that the WDT will run, even if the clock on the OSC1/CLKI and OSC2/CLKO/RA6 pins of the device has been stopped, for example, by execution of a *SLEEP* instruction.

During normal operation, a WDT time-out generates a device Reset (Watchdog Timer Reset). If the device is in Sleep mode, a WDT time-out causes the device to wake-up and continue with normal operation (Watchdog Timer wake-up). The \overline{TO} bit in the RCON register will be cleared upon a WDT time-out.

The Watchdog Timer is enabled/disabled by a device configuration bit. If the WDT is enabled, software execution may not disable this function. When the WDTEEN configuration bit is cleared, the SWDTEN bit enables/disables the operation of the WDT.

The WDT time-out period values may be found in the Electrical Specifications section under parameter #31. Values for the WDT postscaler may be assigned using the configuration bits.

- Note 1:** The *CLRWDT* and *SLEEP* instructions clear the WDT and the postscaler, if assigned to the WDT and prevent it from timing out and generating a device Reset condition.
- 2:** When a *CLRWDT* instruction is executed and the postscaler is assigned to the WDT, the postscaler count will be cleared, but the postscaler assignment is not changed.

23.2.1 CONTROL REGISTER

Register 23-15 shows the WDTCON register. This is a readable and writable register, which contains a control bit that allows software to override the WDT enable configuration bit, only when the configuration bit has disabled the WDT.

REGISTER 23-15: WDTCON REGISTER

U-0	U-0	U-0	U-0	U-0	U-0	U-0	R/W-0
—	—	—	—	—	—	—	SWDTEN
bit 7							bit 0

bit 7-1 **Unimplemented:** Read as '0'

bit 0 **SWDTEN:** Software Controlled Watchdog Timer Enable bit

1 = Watchdog Timer is on

0 = Watchdog Timer is turned off if the WDTEEN configuration bit in the configuration register = 0

Legend:

R = Readable bit

W = Writable bit

U = Unimplemented bit, read as '0'

- n = Value at POR

'1' = Bit is set

'0' = Bit is cleared

x = Bit is unknown

PIC18F6520/8520/6620/8620/6720/8720

23.2.2 WDT POSTSCALER

The WDT has a postscaler that can extend the WDT Reset period. The postscaler is selected at the time of the device programming by the value written to the CONFIG2H Configuration register.

FIGURE 23-1: WATCHDOG TIMER BLOCK DIAGRAM

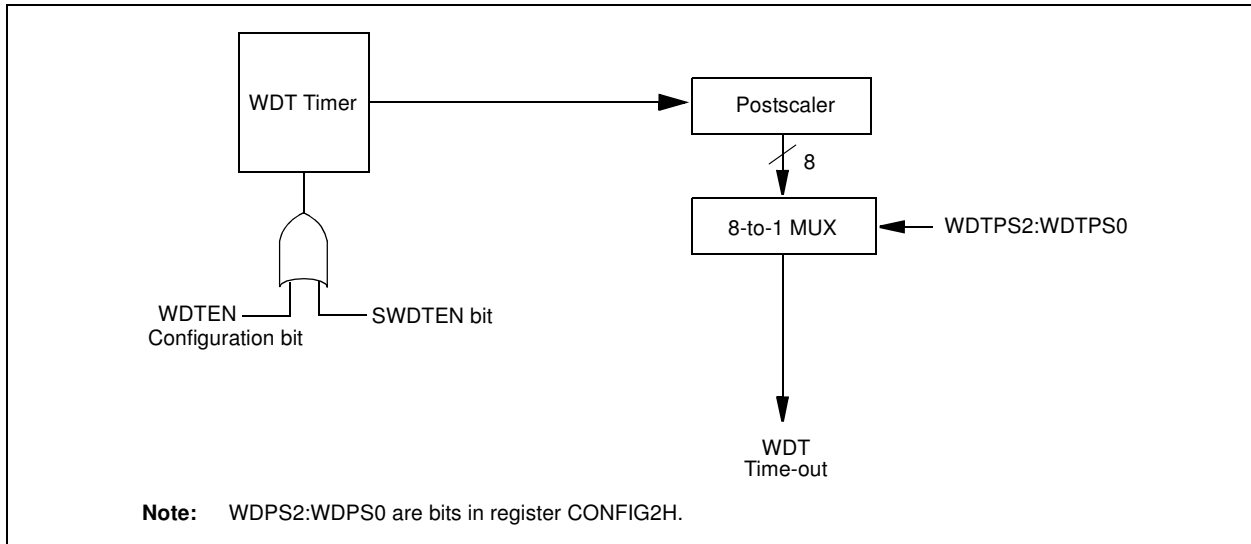

TABLE 23-2: SUMMARY OF WATCHDOG TIMER REGISTERS

Name	Bit 7	Bit 6	Bit 5	Bit 4	Bit 3	Bit 2	Bit 1	Bit 0
CONFIG2H	—	—	—	—	WDTPS2	WDTPS2	WDTPS0	WDTEN
RCON	IPEN	—	—	\overline{RI}	\overline{TO}	\overline{PD}	\overline{POR}	\overline{BOR}
WDTCON	—	—	—	—	—	—	—	SWDTEN

Legend: Shaded cells are not used by the Watchdog Timer.

PIC18F6520/8520/6620/8620/6720/8720

23.3 Power-down Mode (Sleep)

Power-down mode is entered by executing a `SLEEP` instruction.

If enabled, the Watchdog Timer will be cleared, but keeps running, the `PD` bit (`RCON<3>`) is cleared, the `TO` (`RCON<4>`) bit is set and the oscillator driver is turned off. The I/O ports maintain the status they had before the `SLEEP` instruction was executed (driving high, low or high-impedance).

For lowest current consumption in this mode, place all I/O pins at either `VDD` or `VSS`, ensure no external circuitry is drawing current from the I/O pin, power-down the A/D and disable external clocks. Pull all I/O pins that are high-impedance inputs, high or low externally, to avoid switching currents caused by floating inputs. The `T0CKI` input should also be at `VDD` or `VSS` for lowest current consumption. The contribution from on-chip pull-ups on `PORTB` should be considered.

The `MCLR` pin must be at a logic high level (`VIHMC`).

23.3.1 WAKE-UP FROM SLEEP

The device can wake-up from Sleep through one of the following events:

1. External Reset input on `MCLR` pin.
2. Watchdog Timer Wake-up (if WDT was enabled).
3. Interrupt from `INT` pin, `RB` port change or a peripheral interrupt.

The following peripheral interrupts can wake the device from Sleep:

1. PSP read or write.
2. `TMR1` interrupt. Timer1 must be operating as an asynchronous counter.
3. `TMR3` interrupt. Timer3 must be operating as an asynchronous counter.
4. `CCP` Capture mode interrupt.
5. Special event trigger (Timer1 in Asynchronous mode using an external clock).
6. `MSSP` (Start/Stop) bit detect interrupt.
7. `MSSP` transmit or receive in Slave mode (`SPI/I2C`).
8. `USART` RX or TX (Synchronous Slave mode).
9. A/D conversion (when A/D clock source is RC).
10. `EEPROM` write operation complete.
11. `LVD` interrupt.

Other peripherals cannot generate interrupts, since during Sleep, no on-chip clocks are present.

External `MCLR` Reset will cause a device Reset. All other events are considered a continuation of program execution and will cause a “wake-up”. The `TO` and `PD` bits in the `RCON` register can be used to determine the cause of the device Reset. The `PD` bit, which is set on power-up, is cleared when Sleep is invoked. The `TO` bit is cleared if a WDT time-out occurred (and caused wake-up).

When the `SLEEP` instruction is being executed, the next instruction (`PC + 2`) is prefetched. For the device to wake-up through an interrupt event, the corresponding interrupt enable bit must be set (enabled). Wake-up is regardless of the state of the `GIE` bit. If the `GIE` bit is clear (disabled), the device continues execution at the instruction after the `SLEEP` instruction. If the `GIE` bit is set (enabled), the device executes the instruction after the `SLEEP` instruction and then branches to the interrupt address. In cases where the execution of the instruction following `SLEEP` is not desirable, the user should have a `NOP` after the `SLEEP` instruction.

23.3.2 WAKE-UP USING INTERRUPTS

When global interrupts are disabled (`GIE` cleared) and any interrupt source has both its interrupt enable bit and interrupt flag bit set, one of the following will occur:

- If an interrupt condition (interrupt flag bit and interrupt enable bits are set) occurs **before** the execution of a `SLEEP` instruction, the `SLEEP` instruction will complete as a `NOP`. Therefore, the `WDT` and `WDT` postscaler will not be cleared, the `TO` bit will not be set and `PD` bits will not be cleared.
- If the interrupt condition occurs **during or after** the execution of a `SLEEP` instruction, the device will immediately wake-up from Sleep. The `SLEEP` instruction will be completely executed before the wake-up. Therefore, the `WDT` and `WDT` postscaler will be cleared, the `TO` bit will be set and the `PD` bit will be cleared.

Even if the flag bits were checked before executing a `SLEEP` instruction, it may be possible for flag bits to become set before the `SLEEP` instruction completes. To determine whether a `SLEEP` instruction executed, test the `PD` bit. If the `PD` bit is set, the `SLEEP` instruction was executed as a `NOP`.

To ensure that the `WDT` is cleared, a `CLRWDT` instruction should be executed before a `SLEEP` instruction.

PIC18F6520/8520/6620/8620/6720/8720

FIGURE 23-2: WAKE-UP FROM SLEEP THROUGH INTERRUPT^(1,2)

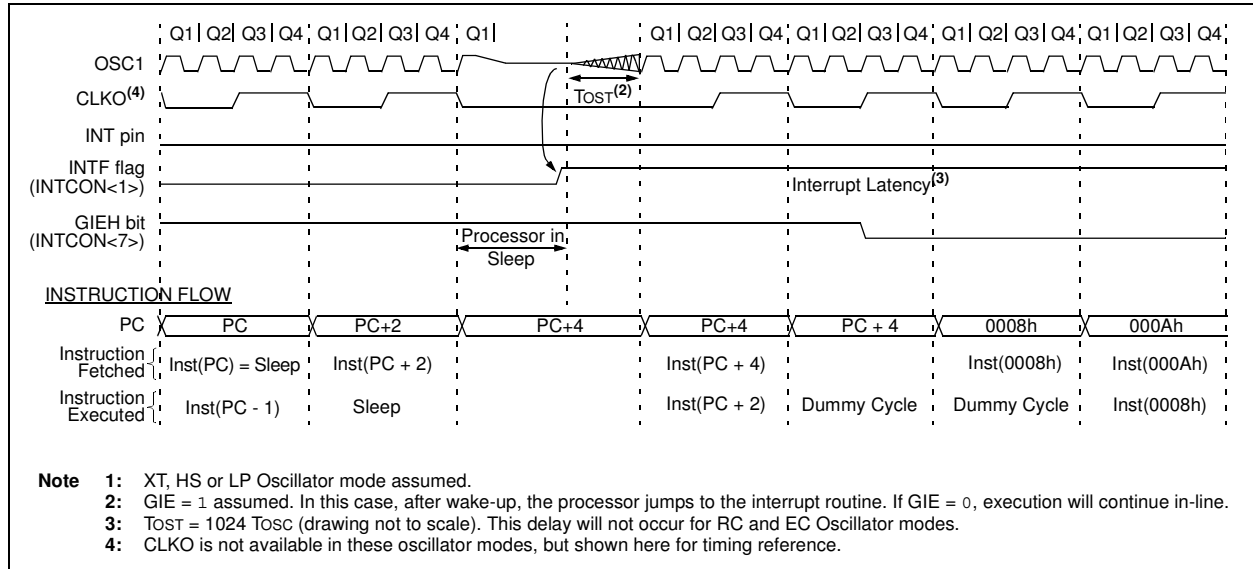

23.4 Program Verification and Code Protection

The overall structure of the code protection on the PIC18 Flash devices differs significantly from other PIC® devices. The user program memory is divided on binary boundaries into individual blocks, each of which has three separate code protection bits associated with it:

- Code-Protect bit (CP_n)
- Write-Protect bit (WRT_n)
- External Block Table Read bit (EBTR_n)

The code protection bits are located in Configuration Registers 5L through 7H. Their locations within the registers are summarized in Table 23-3.

In the PIC18FXX20 family, the block size varies with the size of the user program memory. For PIC18FX520 devices, program memory is divided into four blocks of 8 Kbytes each. The first block is further divided into a boot block of 2 Kbytes and a second block (Block 0) of 6 Kbytes, for a total of five blocks. The organization of the blocks and their associated code protection bits are shown in Figure 23-3.

For PIC18FX620 and PIC18FX720 devices, program memory is divided into blocks of 16 Kbytes. The first block is further divided into a boot block of 512 bytes and a second block (Block 0) of 15.5 Kbytes, for a total of nine blocks. This produces five blocks for 64-Kbyte devices and nine for 128-Kbyte devices. The organization of the blocks and their associated code protection bits are shown in Figure 23-4.

TABLE 23-3: SUMMARY OF CODE PROTECTION REGISTERS

File Name	Bit 7	Bit 6	Bit 5	Bit 4	Bit 3	Bit 2	Bit 1	Bit 0	
300008h	CONFIG5L	CP7 ⁽¹⁾	CP6 ⁽¹⁾	CP5 ⁽¹⁾	CP4 ⁽¹⁾	CP3	CP2	CP1	CP0
300009h	CONFIG5H	CPD	CPB	—	—	—	—	—	—
30000Ah	CONFIG6L	WRT7 ⁽¹⁾	WRT6 ⁽¹⁾	WRT5 ⁽¹⁾	WRT4 ⁽¹⁾	WRT3	WRT2	WRT1	WRT0
30000Bh	CONFIG6H	WRTD	WRTB	WRTC	—	—	—	—	—
30000Ch	CONFIG7L	EBTR7 ⁽¹⁾	EBTR6 ⁽¹⁾	EBTR5 ⁽¹⁾	EBTR4 ⁽¹⁾	EBTR3	EBTR2	EBTR1	EBTR0
30000Dh	CONFIG7H	—	EBTRB	—	—	—	—	—	—

Legend: Shaded cells are unimplemented.

Note 1: Unimplemented in PIC18FX520 and PIC18FX620 devices.

PIC18F6520/8520/6620/8620/6720/8720

23.4.1 PROGRAM MEMORY CODE PROTECTION

The user memory may be read to, or written from, any location using the table read and table write instructions. The device ID may be read with table reads. The configuration registers may be read and written with the table read and table write instructions.

In user mode, the CPn bits have no direct effect. CPn bits inhibit external reads and writes. A block of user memory may be protected from table writes if the WRTn configuration bit is '0'. The EBTRn bits control table reads. For a block of user memory with the EBTRn bit set to '0', a table read instruction that executes from within that block is allowed to read. A table read instruction that executes from a location out-

side of that block is not allowed to read and will result in reading '0's. Figures 23-5 through 23-7 illustrate table write and table read protection using devices with a 16-Kbyte block size as the models. The principles illustrated are identical for devices with an 8-Kbyte block size.

Note: Code protection bits may only be written to a '0' from a '1' state. It is not possible to write a '1' to a bit in the '0' state. Code protection bits are only set to '1' by a full chip erase or block erase function. The full chip erase and block erase functions can only be initiated via ICSP or an external programmer.

FIGURE 23-5: TABLE WRITE (WRTn) DISALLOWED

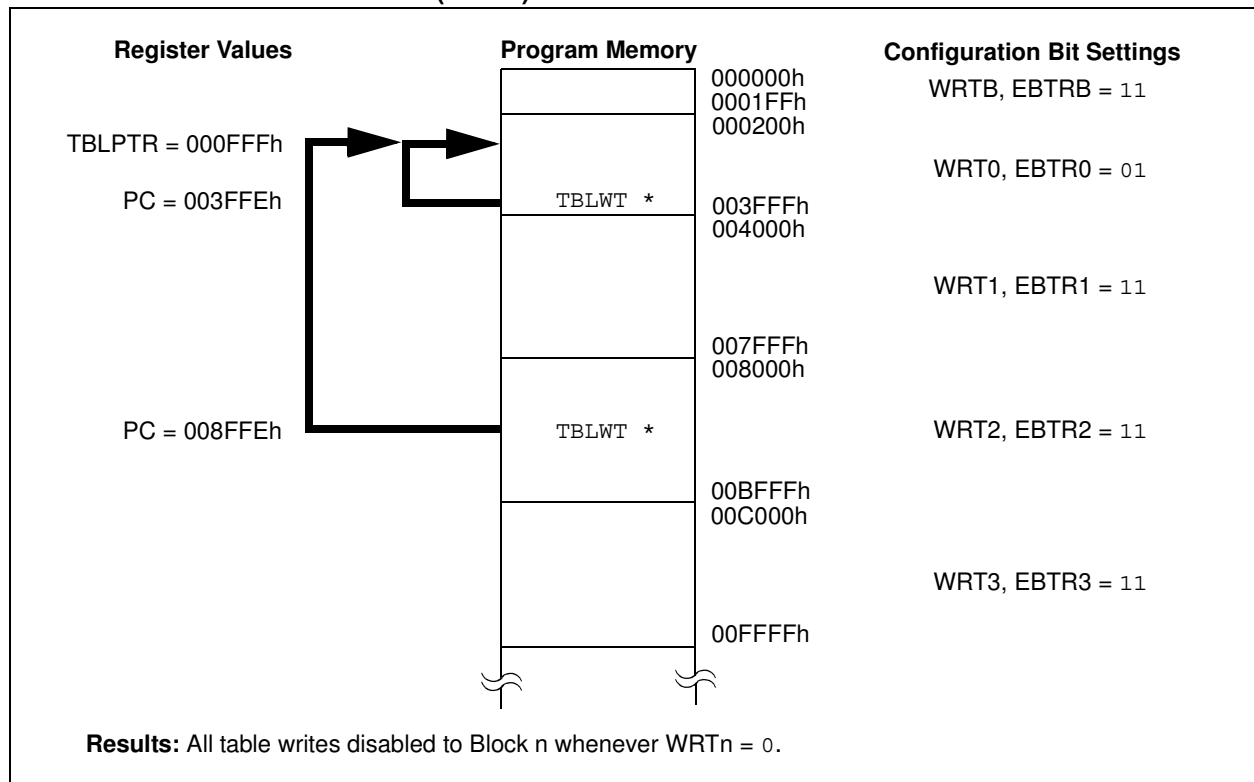

PIC18F6520/8520/6620/8620/6720/8720

FIGURE 23-6: EXTERNAL BLOCK TABLE READ (EBTRn) DISALLOWED

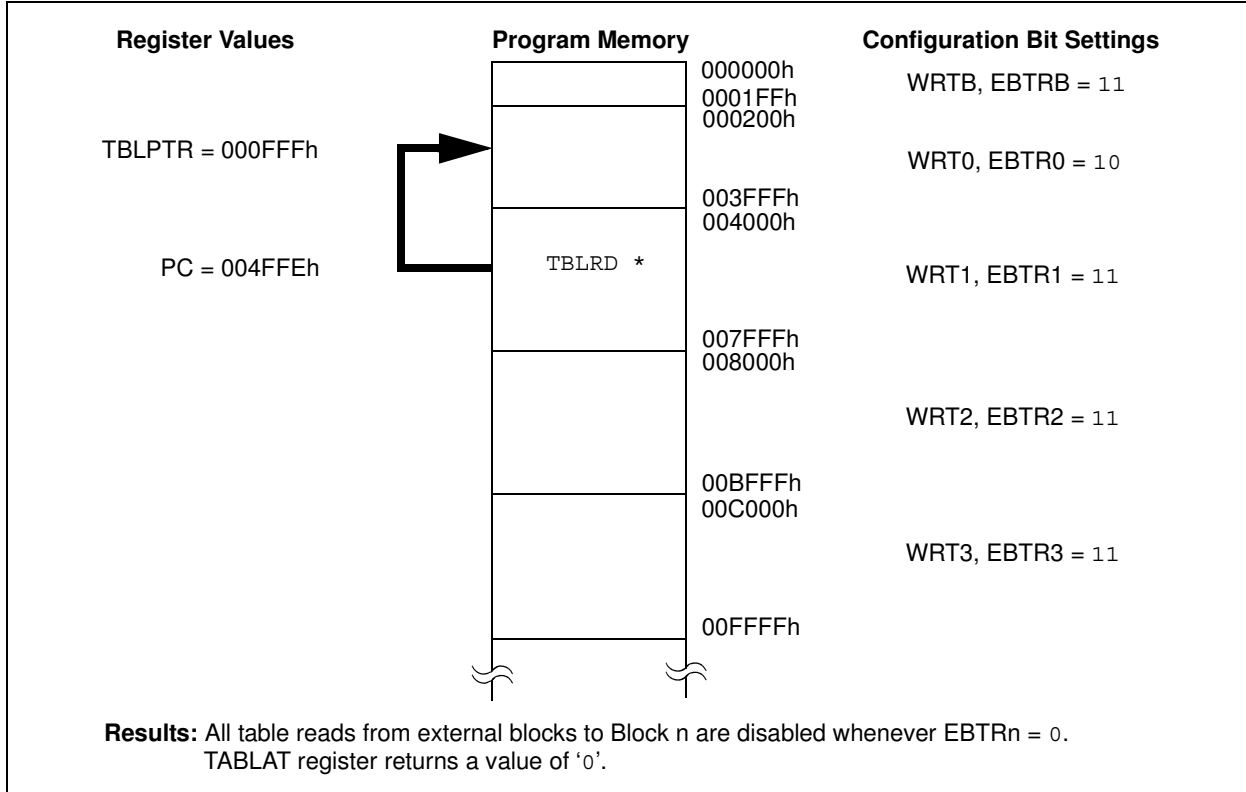
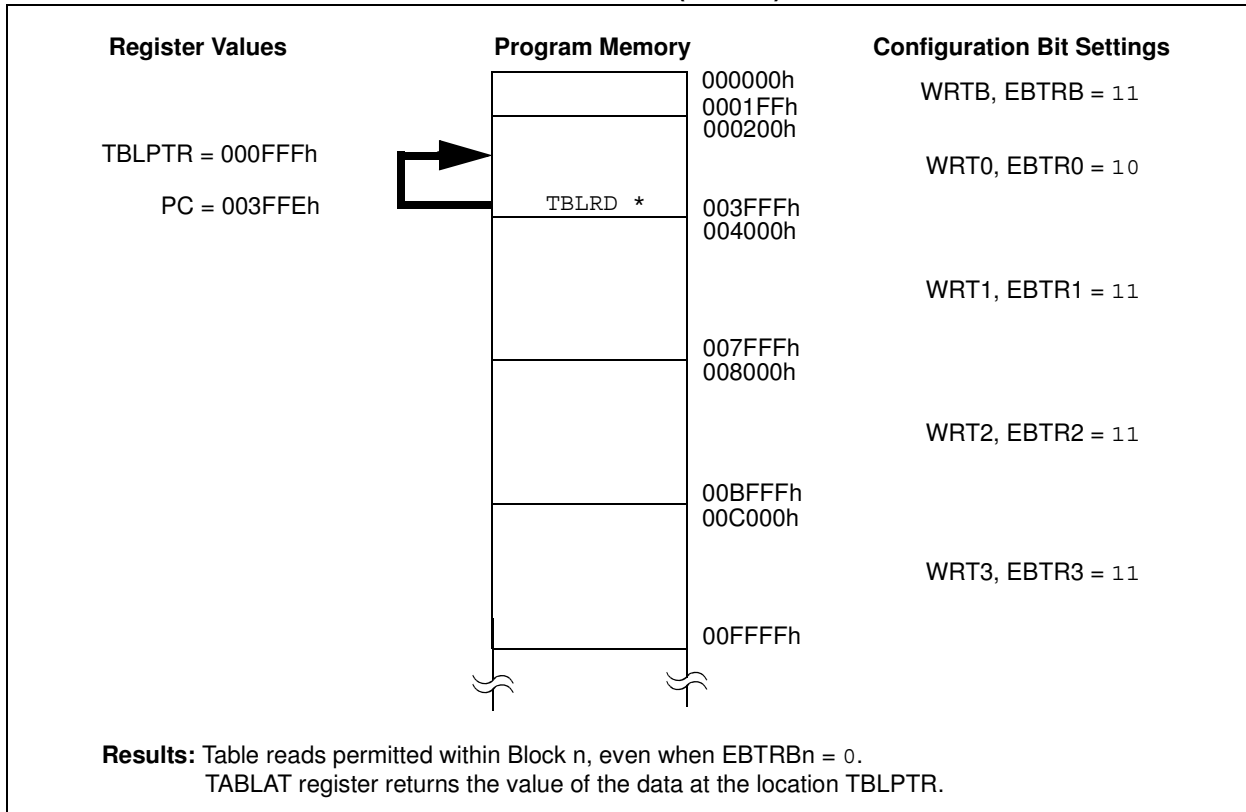

FIGURE 23-7: EXTERNAL BLOCK TABLE READ (EBTRn) ALLOWED



PIC18F6520/8520/6620/8620/6720/8720

23.4.2 DATA EEPROM CODE PROTECTION

The entire data EEPROM is protected from external reads and writes by two bits: CPD and WRTD. CPD inhibits external reads and writes of data EEPROM. WRTD inhibits external writes to data EEPROM. The CPU can continue to read and write data EEPROM, regardless of the protection bit settings.

23.4.3 CONFIGURATION REGISTER PROTECTION

The configuration registers can be write-protected. The WRTC bit controls protection of the configuration registers. In user mode, the WRTC bit is readable only. WRTC can only be written via ICSP or an external programmer.

23.5 ID Locations

Eight memory locations (200000h-200007h) are designated as ID locations, where the user can store checksum or other code identification numbers. These locations are accessible during normal execution through the TBLRD and TBLWT instructions or during program/verify. The ID locations can be read when the device is code-protected.

23.6 In-Circuit Serial Programming

PIC18FX520/X620/X720 microcontrollers can be serially programmed while in the end application circuit. This is simply done with two lines for clock and data and three other lines for power, ground and the programming voltage. This allows customers to manufacture boards with unprogrammed devices and then program the microcontroller just before shipping the product. This also allows the most recent firmware or a custom firmware to be programmed.

Note: When performing In-Circuit Serial Programming, verify that power is connected to **all** VDD and AVDD pins of the microcontroller and that **all** VSS and AVSS pins are grounded.

23.7 In-Circuit Debugger

When the DEBUG bit in the CONFIG4L Configuration register is programmed to a '0', the In-Circuit Debugger functionality is enabled. This function allows simple debugging functions when used with MPLAB® IDE. When the microcontroller has this feature enabled, some of the resources are not available for general use. Table 23-4 shows which features are consumed by the background debugger.

TABLE 23-4: DEBUGGER RESOURCES

I/O pins	RB6, RB7
Stack	2 levels
Program Memory	Last 576 bytes
Data Memory	Last 10 bytes

To use the In-Circuit Debugger function of the microcontroller, the design must implement In-Circuit Serial Programming connections to MCLR/VPP, VDD, GND, RB7 and RB6. This will interface to the In-Circuit Debugger module available from Microchip or one of the third party development tool companies.

23.8 Low-Voltage ICSP Programming

The LVP bit in the CONFIG4L Configuration register enables Low-Voltage ICSP Programming. This mode allows the microcontroller to be programmed via ICSP using a VDD source in the operating voltage range. This only means that VPP does not have to be brought to VIH, but can instead be left at the normal operating voltage. In this mode, the RB5/PGM pin is dedicated to the programming function and ceases to be a general purpose I/O pin. During programming, VDD is applied to the MCLR/VPP pin. To enter Programming mode, VDD must be applied to the RB5/PGM pin, provided the LVP bit is set. The LVP bit defaults to a '1' from the factory.

- Note 1:** The High-Voltage Programming mode is always available, regardless of the state of the LVP bit, by applying VIH to the MCLR pin.
- 2:** While in Low-Voltage ICSP mode, the RB5 pin can no longer be used as a general purpose I/O pin and should be held low during normal operation.
- 3:** When using Low-Voltage ICSP Programming (LVP) and the pull-ups on PORTB are enabled, bit 5 in the TRISB register must be cleared to disable the pull-up on RB5 and ensure the proper operation of the device.

If Low-Voltage Programming mode is not used, the LVP bit can be programmed to a '0' and RB5/PGM becomes a digital I/O pin. However, the LVP bit may only be programmed when programming is entered with VIH on MCLR/VPP.

It should be noted that once the LVP bit is programmed to '0', only the High-Voltage Programming mode is available and only High-Voltage Programming mode can be used to program the device.

When using Low-Voltage ICSP Programming, the part must be supplied 4.5V to 5.5V if a bulk erase will be executed. This includes reprogramming of the code-protect bits from an on state to an off state. For all other cases of Low-Voltage ICSP, the part may be programmed at the normal operating voltage. This means unique user IDs or user code can be reprogrammed or added.

PIC18F6520/8520/6620/8620/6720/8720

NOTES:

24.0 INSTRUCTION SET SUMMARY

The PIC18 instruction set adds many enhancements to the previous PIC MCU instruction sets, while maintaining an easy migration from these PIC MCU instruction sets.

Most instructions are a single program memory word (16 bits), but there are three instructions that require two program memory locations.

Each single-word instruction is a 16-bit word divided into an opcode, which specifies the instruction type and one or more operands, which further specify the operation of the instruction.

The instruction set is highly orthogonal and is grouped into four basic categories:

- **Byte-oriented** operations
- **Bit-oriented** operations
- **Literal** operations
- **Control** operations

The PIC18 instruction set summary in Table 24-1 lists **byte-oriented**, **bit-oriented**, **literal** and **control** operations. Table 24-1 shows the opcode field descriptions.

Most **byte-oriented** instructions have three operands:

1. The file register (specified by 'f')
2. The destination of the result (specified by 'd')
3. The accessed memory (specified by 'a')

The file register designator 'f' specifies which file register is to be used by the instruction.

The destination designator 'd' specifies where the result of the operation is to be placed. If 'd' is zero, the result is placed in the WREG register. If 'd' is one, the result is placed in the file register specified in the instruction.

All **bit-oriented** instructions have three operands:

1. The file register (specified by 'f')
2. The bit in the file register (specified by 'b')
3. The accessed memory (specified by 'a')

The bit field designator 'b' selects the number of the bit affected by the operation, while the file register designator 'f' represents the number of the file in which the bit is located.

The **literal** instructions may use some of the following operands:

- A literal value to be loaded into a file register (specified by 'k')
- The desired FSR register to load the literal value into (specified by 'f')
- No operand required (specified by '—')

The **control** instructions may use some of the following operands:

- A program memory address (specified by 'n')
- The mode of the CALL or RETURN instructions (specified by 's')
- The mode of the table read and table write instructions (specified by 'm')
- No operand required (specified by '—')

All instructions are a single word, except for three double-word instructions. These three instructions were made double-word instructions so that all the required information is available in these 32 bits. In the second word, the 4 MSBs are '1's. If this second word is executed as an instruction (by itself), it will execute as a NOP.

All single-word instructions are executed in a single instruction cycle, unless a conditional test is true or the program counter is changed as a result of the instruction. In these cases, the execution takes two instruction cycles, with the additional instruction cycle(s) executed as a NOP.

The double-word instructions execute in two instruction cycles.

One instruction cycle consists of four oscillator periods. Thus, for an oscillator frequency of 4 MHz, the normal instruction execution time is 1 μ s. If a conditional test is true, or the program counter is changed as a result of an instruction, the instruction execution time is 2 μ s. Two-word branch instructions (if true) would take 3 μ s.

Figure 24-1 shows the general formats that the instructions can have.

All examples use the format 'nnh' to represent a hexadecimal number, where 'h' signifies a hexadecimal digit.

The Instruction Set Summary, shown in Table 24-1, lists the instructions recognized by the Microchip Assembler (MPASM™).

Section 24.1 "Instruction Set" provides a description of each instruction.

PIC18F6520/8520/6620/8620/6720/8720

TABLE 24-1: OPCODE FIELD DESCRIPTIONS

Field	Description
a	RAM access bit a = 0: RAM location in Access RAM (BSR register is ignored) a = 1: RAM bank is specified by BSR register
bbb	Bit address within an 8-bit file register (0 to 7).
BSR	Bank Select Register. Used to select the current RAM bank.
d	Destination select bit d = 0: store result in WREG d = 1: store result in file register f
dest	Destination either the WREG register or the specified register file location.
f	8-bit Register file address (0x00 to 0xFF).
fs	12-bit Register file address (0x000 to 0xFFF). This is the source address.
fd	12-bit Register file address (0x000 to 0xFFF). This is the destination address.
k	Literal field, constant data or label (may be either an 8-bit, 12-bit or a 20-bit value).
label	Label name.
mmm	The mode of the TBLPTR register for the table read and table write instructions. Only used with table read and table write instructions:
*	No Change to register (such as TBLPTR with table reads and writes)
*+	Post-Increment register (such as TBLPTR with table reads and writes)
*-	Post-Decrement register (such as TBLPTR with table reads and writes)
+*	Pre-Increment register (such as TBLPTR with table reads and writes)
n	The relative address (2's complement number) for relative branch instructions, or the direct address for Call/Branch and Return instructions.
PRODH	Product of Multiply High Byte.
PRODL	Product of Multiply Low Byte.
s	Fast Call/Return mode select bit s = 0: do not update into/from shadow registers s = 1: certain registers loaded into/from shadow registers (Fast mode)
u	Unused or Unchanged.
WREG	Working register (accumulator).
x	Don't care ('0' or '1'). The assembler will generate code with x = 0. It is the recommended form of use for compatibility with all Microchip software tools.
TBLPTR	21-bit Table Pointer (points to a Program Memory location).
TABLAT	8-bit Table Latch.
TOS	Top-of-Stack.
PC	Program Counter.
PCL	Program Counter Low Byte.
PCH	Program Counter High Byte.
PCLATH	Program Counter High Byte Latch.
PCLATU	Program Counter Upper Byte Latch.
GIE	Global Interrupt Enable bit.
WDT	Watchdog Timer.
T \bar{O}	Time-out bit.
P \bar{D}	Power-down bit.
C, DC, Z, OV, N	ALU Status bits: Carry, Digit Carry, Zero, Overflow, Negative.
[]	Optional.
()	Contents.
→	Assigned to.
< >	Register bit field.
∈	In the set of.
<i>italics</i>	User defined term (font is courier).

PIC18F6520/8520/6620/8620/6720/8720

FIGURE 24-1: GENERAL FORMAT FOR INSTRUCTIONS

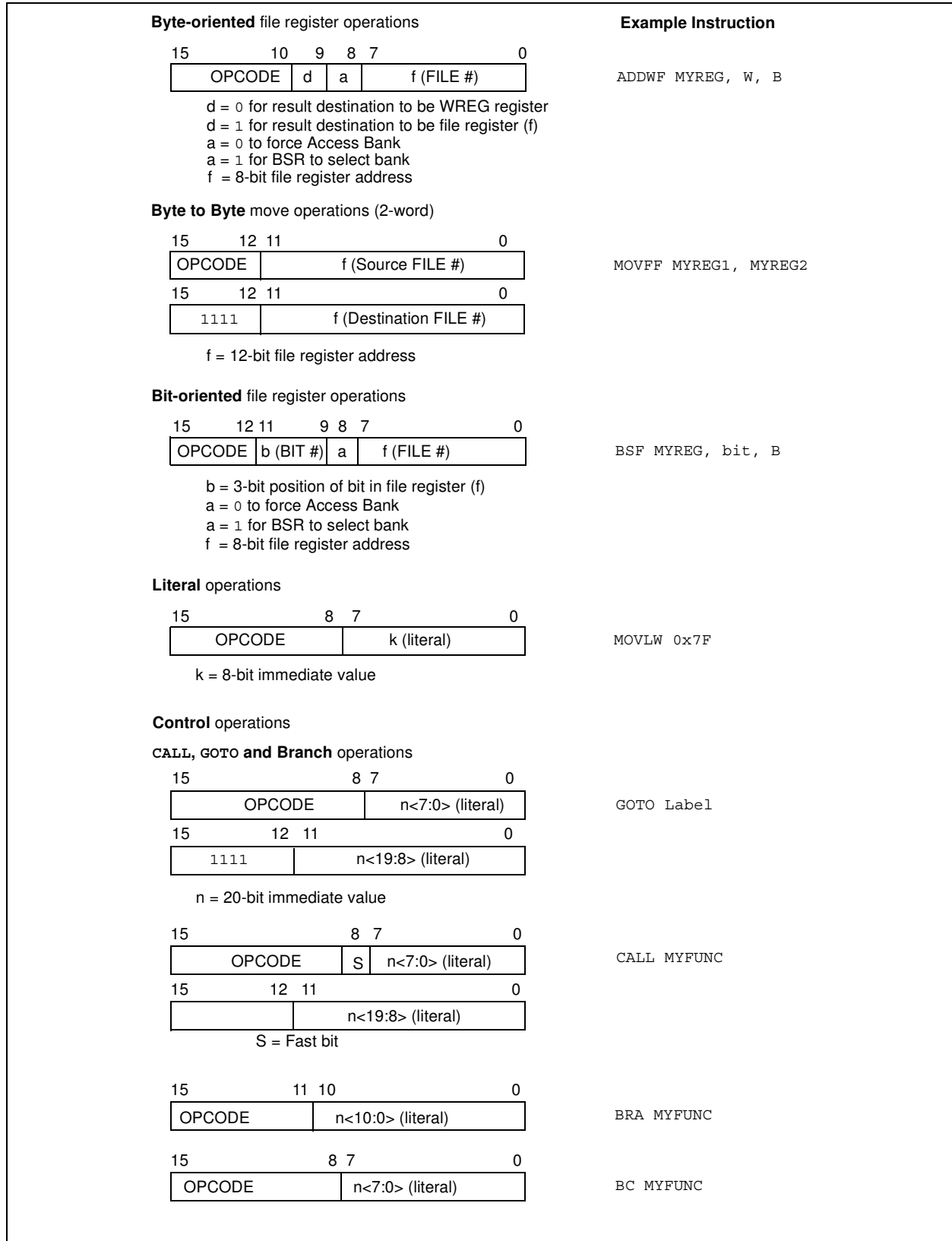

PIC18F6520/8520/6620/8620/6720/8720

TABLE 24-1: PIC18FXXXX INSTRUCTION SET

Mnemonic, Operands	Description	Cycles	16-Bit Instruction Word				Status Affected	Notes	
			MSb			LSb			
BYTE-ORIENTED FILE REGISTER OPERATIONS									
ADDWF	f, d, a	Add WREG and f	1	0010	01da	ffff	ffff	C, DC, Z, OV, N	1, 2
ADDWFC	f, d, a	Add WREG and Carry bit to f	1	0010	00da	ffff	ffff	C, DC, Z, OV, N	1, 2
ANDWF	f, d, a	AND WREG with f	1	0001	01da	ffff	ffff	Z, N	1, 2
CLRF	f, a	Clear f	1	0110	101a	ffff	ffff	Z	2
COMF	f, d, a	Complement f	1	0001	11da	ffff	ffff	Z, N	1, 2
CPFSEQ	f, a	Compare f with WREG, skip =	1 (2 or 3)	0110	001a	ffff	ffff	None	4
CPFSGT	f, a	Compare f with WREG, skip >	1 (2 or 3)	0110	010a	ffff	ffff	None	4
CPFSLT	f, a	Compare f with WREG, skip <	1 (2 or 3)	0110	000a	ffff	ffff	None	1, 2
DECf	f, d, a	Decrement f	1	0000	01da	ffff	ffff	C, DC, Z, OV, N	1, 2, 3, 4
DECFSZ	f, d, a	Decrement f, Skip if 0	1 (2 or 3)	0010	11da	ffff	ffff	None	1, 2, 3, 4
DCFSNZ	f, d, a	Decrement f, Skip if Not 0	1 (2 or 3)	0100	11da	ffff	ffff	None	1, 2
INCF	f, d, a	Increment f	1	0010	10da	ffff	ffff	C, DC, Z, OV, N	1, 2, 3, 4
INCFSZ	f, d, a	Increment f, Skip if 0	1 (2 or 3)	0011	11da	ffff	ffff	None	4
INFSNZ	f, d, a	Increment f, Skip if Not 0	1 (2 or 3)	0100	10da	ffff	ffff	None	1, 2
IORWF	f, d, a	Inclusive OR WREG with f	1	0001	00da	ffff	ffff	Z, N	1, 2
MOVF	f, d, a	Move f	1	0101	00da	ffff	ffff	Z, N	1
MOVFF	f _s , f _d	Move f _s (source) to 1st word f _d (destination) 2nd word	2	1100	ffff	ffff	ffff	None	
MOVWF	f, a	Move WREG to f	1	0110	111a	ffff	ffff	None	
MULWF	f, a	Multiply WREG with f	1	0000	001a	ffff	ffff	None	
NEGF	f, a	Negate f	1	0110	110a	ffff	ffff	C, DC, Z, OV, N	1, 2
RLCF	f, d, a	Rotate Left f through Carry	1	0011	01da	ffff	ffff	C, Z, N	
RLNCF	f, d, a	Rotate Left f (No Carry)	1	0100	01da	ffff	ffff	Z, N	1, 2
RRCF	f, d, a	Rotate Right f through Carry	1	0011	00da	ffff	ffff	C, Z, N	
RRNCF	f, d, a	Rotate Right f (No Carry)	1	0100	00da	ffff	ffff	Z, N	
SETF	f, a	Set f	1	0110	100a	ffff	ffff	None	
SUBFWB	f, d, a	Subtract f from WREG with borrow	1	0101	01da	ffff	ffff	C, DC, Z, OV, N	1, 2
SUBWF	f, d, a	Subtract WREG from f	1	0101	11da	ffff	ffff	C, DC, Z, OV, N	
SUBWFB	f, d, a	Subtract WREG from f with borrow	1	0101	10da	ffff	ffff	C, DC, Z, OV, N	1, 2
SWAPF	f, d, a	Swap nibbles in f	1	0011	10da	ffff	ffff	None	4
TSTFSZ	f, a	Test f, skip if 0	1 (2 or 3)	0110	011a	ffff	ffff	None	1, 2
XORWF	f, d, a	Exclusive OR WREG with f	1	0001	10da	ffff	ffff	Z, N	
BIT-ORIENTED FILE REGISTER OPERATIONS									
BCF	f, b, a	Bit Clear f	1	1001	bbba	ffff	ffff	None	1, 2
BSF	f, b, a	Bit Set f	1	1000	bbba	ffff	ffff	None	1, 2
BTFSC	f, b, a	Bit Test f, Skip if Clear	1 (2 or 3)	1011	bbba	ffff	ffff	None	3, 4
BTFSS	f, b, a	Bit Test f, Skip if Set	1 (2 or 3)	1010	bbba	ffff	ffff	None	3, 4
BTG	f, d, a	Bit Toggle f	1	0111	bbba	ffff	ffff	None	1, 2

- Note 1:** When a Port register is modified as a function of itself (e.g., MOVF PORTB, 1, 0), the value used will be that value present on the pins themselves. For example, if the data latch is '1' for a pin configured as input and is driven low by an external device, the data will be written back with a '0'.
- Note 2:** If this instruction is executed on the TMR0 register (and where applicable, d = 1), the prescaler will be cleared if assigned.
- Note 3:** If Program Counter (PC) is modified or a conditional test is true, the instruction requires two cycles. The second cycle is executed as a NOP.
- Note 4:** Some instructions are 2-word instructions. The second word of these instructions will be executed as a NOP unless the first word of the instruction retrieves the information embedded in these 16 bits. This ensures that all program memory locations have a valid instruction.
- Note 5:** If the table write starts the write cycle to internal memory, the write will continue until terminated.

PIC18F6520/8520/6620/8620/6720/8720

TABLE 24-1: PIC18FXXXX INSTRUCTION SET (CONTINUED)

Mnemonic, Operands	Description	Cycles	16-Bit Instruction Word				Status Affected	Notes	
			MSb	LSb					
CONTROL OPERATIONS									
BC	n	Branch if Carry	1 (2)	1110	0010	nnnn	nnnn	None	
BN	n	Branch if Negative	1 (2)	1110	0110	nnnn	nnnn	None	
BNC	n	Branch if Not Carry	1 (2)	1110	0011	nnnn	nnnn	None	
BNN	n	Branch if Not Negative	1 (2)	1110	0111	nnnn	nnnn	None	
BNOV	n	Branch if Not Overflow	1 (2)	1110	0101	nnnn	nnnn	None	
BNZ	n	Branch if Not Zero	1 (2)	1110	0001	nnnn	nnnn	None	
BOV	n	Branch if Overflow	1 (2)	1110	0100	nnnn	nnnn	None	
BRA	n	Branch Unconditionally	2	1101	0nnn	nnnn	nnnn	None	
BZ	n	Branch if Zero	1 (2)	1110	0000	nnnn	nnnn	None	
CALL	n, s	Call subroutine 1st word	2	1110	110s	kkkk	kkkk	None	
		2nd word		1111	kkkk	kkkk	kkkk		
CLRWDT	—	Clear Watchdog Timer	1	0000	0000	0000	0100	\overline{TO} , \overline{PD}	
DAW	—	Decimal Adjust WREG	1	0000	0000	0000	0111	C	
GOTO	n	Go to address 1st word	2	1110	1111	kkkk	kkkk	None	
		2nd word		1111	kkkk	kkkk	kkkk		
NOP	—	No Operation	1	0000	0000	0000	0000	None	
NOP	—	No Operation	1	1111	xxxx	xxxx	xxxx	None	4
POP	—	Pop top of return stack (TOS)	1	0000	0000	0000	0110	None	
PUSH	—	Push top of return stack (TOS)	1	0000	0000	0000	0101	None	
RCALL	n	Relative Call	2	1101	1nnn	nnnn	nnnn	None	
RESET		Software device Reset	1	0000	0000	1111	1111	All	
RETFIE	s	Return from interrupt enable	2	0000	0000	0001	000s	GIE/GIEH, PEIE/GIEL	
RETLW	k	Return with literal in WREG	2	0000	1100	kkkk	kkkk	None	
RETURN	s	Return from Subroutine	2	0000	0000	0001	001s	None	
SLEEP	—	Go into Standby mode	1	0000	0000	0000	0011	\overline{TO} , \overline{PD}	

- Note 1:** When a Port register is modified as a function of itself (e.g., `MOVF PORTB, 1, 0`), the value used will be that value present on the pins themselves. For example, if the data latch is '1' for a pin configured as input and is driven low by an external device, the data will be written back with a '0'.
- 2:** If this instruction is executed on the TMR0 register (and where applicable, $d = 1$), the prescaler will be cleared if assigned.
- 3:** If Program Counter (PC) is modified or a conditional test is true, the instruction requires two cycles. The second cycle is executed as a NOP.
- 4:** Some instructions are 2-word instructions. The second word of these instructions will be executed as a NOP unless the first word of the instruction retrieves the information embedded in these 16 bits. This ensures that all program memory locations have a valid instruction.
- 5:** If the table write starts the write cycle to internal memory, the write will continue until terminated.

PIC18F6520/8520/6620/8620/6720/8720

TABLE 24-1: PIC18FXXXX INSTRUCTION SET (CONTINUED)

Mnemonic, Operands	Description	Cycles	16-Bit Instruction Word				Status Affected	Notes
			MSb			LSb		
LITERAL OPERATIONS								
ADDLW	k	Add literal and WREG	1	0000	1111	kkkk	kkkk	C, DC, Z, OV, N
ANDLW	k	AND literal with WREG	1	0000	1011	kkkk	kkkk	Z, N
IORLW	k	Inclusive OR literal with WREG	1	0000	1001	kkkk	kkkk	Z, N
LFSR	f, k	Move literal (12-bit) 2nd word to FSRx 1st word	2	1110	1110	00ff	kkkk	None
MOVLB	k	Move literal to BSR<3:0>	1	0000	0001	0000	kkkk	None
MOVLW	k	Move literal to WREG	1	0000	1110	kkkk	kkkk	None
MULLW	k	Multiply literal with WREG	1	0000	1101	kkkk	kkkk	None
RETLW	k	Return with literal in WREG	2	0000	1100	kkkk	kkkk	None
SUBLW	k	Subtract WREG from literal	1	0000	1000	kkkk	kkkk	C, DC, Z, OV, N
XORLW	k	Exclusive OR literal with WREG	1	0000	1010	kkkk	kkkk	Z, N
DATA MEMORY ↔ PROGRAM MEMORY OPERATIONS								
TBLRD*		Table Read	2	0000	0000	0000	1000	None
TBLRD*+		Table Read with post-increment		0000	0000	0000	1001	None
TBLRD*-		Table Read with post-decrement		0000	0000	0000	1010	None
TBLRD+*		Table Read with pre-increment		0000	0000	0000	1011	None
TBLWT*		Table Write	2 (5)	0000	0000	0000	1100	None
TBLWT*+		Table Write with post-increment		0000	0000	0000	1101	None
TBLWT*-		Table Write with post-decrement		0000	0000	0000	1110	None
TBLWT+*		Table Write with pre-increment		0000	0000	0000	1111	None

- Note 1:** When a Port register is modified as a function of itself (e.g., `MOVF PORTB, 1, 0`), the value used will be that value present on the pins themselves. For example, if the data latch is '1' for a pin configured as input and is driven low by an external device, the data will be written back with a '0'.
- 2:** If this instruction is executed on the TMR0 register (and where applicable, $d = 1$), the prescaler will be cleared if assigned.
- 3:** If Program Counter (PC) is modified or a conditional test is true, the instruction requires two cycles. The second cycle is executed as a `NOOP`.
- 4:** Some instructions are 2-word instructions. The second word of these instructions will be executed as a `NOOP` unless the first word of the instruction retrieves the information embedded in these 16 bits. This ensures that all program memory locations have a valid instruction.
- 5:** If the table write starts the write cycle to internal memory, the write will continue until terminated.

PIC18F6520/8520/6620/8620/6720/8720

24.1 Instruction Set

ADDLW ADD literal to W

Syntax: [*label*] ADDLW *k*

Operands: $0 \leq k \leq 255$

Operation: $(W) + k \rightarrow W$

Status Affected: N, OV, C, DC, Z

Encoding:

0000	1111	kkkk	kkkk
------	------	------	------

Description: The contents of W are added to the 8-bit literal 'k' and the result is placed in W.

Words: 1

Cycles: 1

Q Cycle Activity:

Q1	Q2	Q3	Q4
Decode	Read literal 'k'	Process Data	Write to W

Example: ADDLW 0x15

Before Instruction

W = 0x10

After Instruction

W = 0x25

ADDWF ADD W to f

Syntax: [*label*] ADDWF *f* [,d [,a] f [,d [,a]

Operands: $0 \leq f \leq 255$
 $d \in [0,1]$
 $a \in [0,1]$

Operation: $(W) + (f) \rightarrow \text{dest}$

Status Affected: N, OV, C, DC, Z

Encoding:

0010	01da	ffff	ffff
------	------	------	------

Description: Add W to register 'f'. If 'd' is '0', the result is stored in W. If 'd' is '1', the result is stored back in register 'f' (default). If 'a' is '0', the Access Bank will be selected. If 'a' is '1', the BSR is used.

Words: 1

Cycles: 1

Q Cycle Activity:

Q1	Q2	Q3	Q4
Decode	Read register 'f'	Process Data	Write to destination

Example: ADDWF REG, 0, 0

Before Instruction

W = 0x17

REG = 0xC2

After Instruction

W = 0xD9

REG = 0xC2

PIC18F6520/8520/6620/8620/6720/8720

ADDWFC ADD W and Carry bit to f

Syntax: [*label*] ADDWFC f [,d [,a]]

Operands: $0 \leq f \leq 255$
 $d \in [0,1]$
 $a \in [0,1]$

Operation: $(W) + (f) + (C) \rightarrow \text{dest}$

Status Affected: N, OV, C, DC, Z

Encoding:

0010	00da	ffff	ffff
------	------	------	------

Description: Add W, the Carry flag and data memory location 'f'. If 'd' is '0', the result is placed in W. If 'd' is '1', the result is placed in data memory location 'f'. If 'a' is '0', the Access Bank will be selected. If 'a' is '1', the BSR will not be overridden.

Words: 1

Cycles: 1

Q Cycle Activity:

Q1	Q2	Q3	Q4
Decode	Read register 'f'	Process Data	Write to destination

Example: ADDWFC REG, 0, 1

Before Instruction

Carry bit = 1
 REG = 0x02
 W = 0x4D

After Instruction

Carry bit = 0
 REG = 0x02
 W = 0x50

ANDLW AND literal with W

Syntax: [*label*] ANDLW k

Operands: $0 \leq k \leq 255$

Operation: $(W) .\text{AND. } k \rightarrow W$

Status Affected: N, Z

Encoding:

0000	1011	kkkk	kkkk
------	------	------	------

Description: The contents of W are AND'ed with the 8-bit literal 'k'. The result is placed in W.

Words: 1

Cycles: 1

Q Cycle Activity:

Q1	Q2	Q3	Q4
Decode	Read literal 'k'	Process Data	Write to W

Example: ANDLW 0x5F

Before Instruction

W = 0xA3

After Instruction

W = 0x03

PIC18F6520/8520/6620/8620/6720/8720

ANDWF **AND W with f**

Syntax: [*label*] ANDWF f [,d [,a]

Operands: $0 \leq f \leq 255$
 $d \in [0,1]$
 $a \in [0,1]$

Operation: (W) .AND. (f) → dest

Status Affected: N, Z

Encoding:

0001	01da	ffff	ffff
------	------	------	------

Description: The contents of W are AND'ed with register 'f'. If 'd' is '0', the result is stored in W. If 'd' is '1', the result is stored back in register 'f' (default). If 'a' is '0', the Access Bank will be selected. If 'a' is '1', the BSR will not be overridden (default).

Words: 1

Cycles: 1

Q Cycle Activity:

Q1	Q2	Q3	Q4
Decode	Read register 'f'	Process Data	Write to destination

Example: ANDWF REG, 0, 0

Before Instruction

W = 0x17
 REG = 0xC2

After Instruction

W = 0x02
 REG = 0xC2

BC **Branch if Carry**

Syntax: [*label*] BC n

Operands: $-128 \leq n \leq 127$

Operation: if Carry bit is '1'
 (PC) + 2 + 2n → PC

Status Affected: None

Encoding:

1110	0010	nnnn	nnnn
------	------	------	------

Description: If the Carry bit is '1', then the program will branch. The 2's complement number '2n' is added to the PC. Since the PC will have incremented to fetch the next instruction, the new address will be PC+2+2n. This instruction is then a two-cycle instruction.

Words: 1

Cycles: 1(2)

Q Cycle Activity:

If Jump:

Q1	Q2	Q3	Q4
Decode	Read literal 'n'	Process Data	Write to PC
No operation	No operation	No operation	No operation

If No Jump:

Q1	Q2	Q3	Q4
Decode	Read literal 'n'	Process Data	No operation

Example: HERE BC 5

Before Instruction

PC = address (HERE)

After Instruction

If Carry = 1;
 PC = address (HERE+12)
 If Carry = 0;
 PC = address (HERE+2)

PIC18F6520/8520/6620/8620/6720/8720

BCF	Bit Clear f								
Syntax:	[<i>label</i>] BCF f,b[<i>a</i>]								
Operands:	0 ≤ f ≤ 255 0 ≤ b ≤ 7 a ∈ [0,1]								
Operation:	0 → f								
Status Affected:	None								
Encoding:	<table border="1" style="display: inline-table; border-collapse: collapse;"> <tr> <td style="padding: 2px;">1001</td> <td style="padding: 2px;">bbba</td> <td style="padding: 2px;">ffff</td> <td style="padding: 2px;">ffff</td> </tr> </table>	1001	bbba	ffff	ffff				
1001	bbba	ffff	ffff						
Description:	Bit 'b' in register 'f' is cleared. If 'a' is '0', the Access Bank will be selected, overriding the BSR value. If 'a' = 1, then the bank will be selected as per the BSR value (default).								
Words:	1								
Cycles:	1								
Q Cycle Activity:	<table border="1" style="display: inline-table; border-collapse: collapse; text-align: center;"> <tr> <td style="padding: 2px;">Q1</td> <td style="padding: 2px;">Q2</td> <td style="padding: 2px;">Q3</td> <td style="padding: 2px;">Q4</td> </tr> <tr> <td style="padding: 2px;">Decode</td> <td style="padding: 2px;">Read register 'f'</td> <td style="padding: 2px;">Process Data</td> <td style="padding: 2px;">Write register 'f'</td> </tr> </table>	Q1	Q2	Q3	Q4	Decode	Read register 'f'	Process Data	Write register 'f'
Q1	Q2	Q3	Q4						
Decode	Read register 'f'	Process Data	Write register 'f'						

Example: BCF FLAG_REG, 7, 0

Before Instruction
 FLAG_REG = 0xC7
 After Instruction
 FLAG_REG = 0x47

BN	Branch if Negative												
Syntax:	[<i>label</i>] BN n												
Operands:	-128 ≤ n ≤ 127												
Operation:	if Negative bit is '1' (PC) + 2 + 2n → PC												
Status Affected:	None												
Encoding:	<table border="1" style="display: inline-table; border-collapse: collapse;"> <tr> <td style="padding: 2px;">1110</td> <td style="padding: 2px;">0110</td> <td style="padding: 2px;">nnnn</td> <td style="padding: 2px;">nnnn</td> </tr> </table>	1110	0110	nnnn	nnnn								
1110	0110	nnnn	nnnn										
Description:	If the Negative bit is '1', then the program will branch. The 2's complement number '2n' is added to the PC. Since the PC will have incremented to fetch the next instruction, the new address will be PC+2+2n. This instruction is then a two-cycle instruction.												
Words:	1												
Cycles:	1(2)												
Q Cycle Activity:	<table border="1" style="display: inline-table; border-collapse: collapse; text-align: center;"> <tr> <td style="padding: 2px;">Q1</td> <td style="padding: 2px;">Q2</td> <td style="padding: 2px;">Q3</td> <td style="padding: 2px;">Q4</td> </tr> <tr> <td style="padding: 2px;">Decode</td> <td style="padding: 2px;">Read literal 'n'</td> <td style="padding: 2px;">Process Data</td> <td style="padding: 2px;">Write to PC</td> </tr> <tr> <td style="padding: 2px;">No operation</td> <td style="padding: 2px;">No operation</td> <td style="padding: 2px;">No operation</td> <td style="padding: 2px;">No operation</td> </tr> </table>	Q1	Q2	Q3	Q4	Decode	Read literal 'n'	Process Data	Write to PC	No operation	No operation	No operation	No operation
Q1	Q2	Q3	Q4										
Decode	Read literal 'n'	Process Data	Write to PC										
No operation	No operation	No operation	No operation										
If Jump:	<table border="1" style="display: inline-table; border-collapse: collapse; text-align: center;"> <tr> <td style="padding: 2px;">Q1</td> <td style="padding: 2px;">Q2</td> <td style="padding: 2px;">Q3</td> <td style="padding: 2px;">Q4</td> </tr> <tr> <td style="padding: 2px;">Decode</td> <td style="padding: 2px;">Read literal 'n'</td> <td style="padding: 2px;">Process Data</td> <td style="padding: 2px;">No operation</td> </tr> </table>	Q1	Q2	Q3	Q4	Decode	Read literal 'n'	Process Data	No operation				
Q1	Q2	Q3	Q4										
Decode	Read literal 'n'	Process Data	No operation										

If No Jump:

Q1	Q2	Q3	Q4
Decode	Read literal 'n'	Process Data	No operation

Example: HERE BN Jump

Before Instruction
 PC = address (HERE)

After Instruction
 If Negative = 1;
 PC = address (Jump)
 If Negative = 0;
 PC = address (HERE+2)

PIC18F6520/8520/6620/8620/6720/8720

BNC **Branch if Not Carry**

Syntax: [*label*] BNC n

Operands: -128 ≤ n ≤ 127

Operation: if Carry bit is '0'
(PC) + 2 + 2n → PC

Status Affected: None

Encoding:

1110	0011	nnnn	nnnn
------	------	------	------

Description: If the Carry bit is '0', then the program will branch. The 2's complement number '2n' is added to the PC. Since the PC will have incremented to fetch the next instruction, the new address will be PC+2+2n. This instruction is then a two-cycle instruction.

Words: 1

Cycles: 1(2)

Q Cycle Activity:

If Jump:

Q1	Q2	Q3	Q4
Decode	Read literal 'n'	Process Data	Write to PC
No operation	No operation	No operation	No operation

If No Jump:

Q1	Q2	Q3	Q4
Decode	Read literal 'n'	Process Data	No operation

Example: HERE BNC Jump

Before Instruction
PC = address (HERE)

After Instruction

If Carry	=	0;
PC	=	address (Jump)
If Carry	=	1;
PC	=	address (HERE+2)

BNN **Branch if Not Negative**

Syntax: [*label*] BNN n

Operands: -128 ≤ n ≤ 127

Operation: if Negative bit is '0'
(PC) + 2 + 2n → PC

Status Affected: None

Encoding:

1110	0111	nnnn	nnnn
------	------	------	------

Description: If the Negative bit is '0', then the program will branch. The 2's complement number '2n' is added to the PC. Since the PC will have incremented to fetch the next instruction, the new address will be PC+2+2n. This instruction is then a two-cycle instruction.

Words: 1

Cycles: 1(2)

Q Cycle Activity:

If Jump:

Q1	Q2	Q3	Q4
Decode	Read literal 'n'	Process Data	Write to PC
No operation	No operation	No operation	No operation

If No Jump:

Q1	Q2	Q3	Q4
Decode	Read literal 'n'	Process Data	No operation

Example: HERE BNN Jump

Before Instruction
PC = address (HERE)

After Instruction

If Negative	=	0;
PC	=	address (Jump)
If Negative	=	1;
PC	=	address (HERE+2)

PIC18F6520/8520/6620/8620/6720/8720

BNOV Branch if Not Overflow

Syntax: [*label*] BNOV n

Operands: $-128 \leq n \leq 127$

Operation: if Overflow bit is '0'
(PC) + 2 + 2n → PC

Status Affected: None

Encoding:

1110	0101	nnnn	nnnn
------	------	------	------

Description: If the Overflow bit is '0', then the program will branch. The 2's complement number '2n' is added to the PC. Since the PC will have incremented to fetch the next instruction, the new address will be PC+2+2n. This instruction is then a two-cycle instruction.

Words: 1

Cycles: 1(2)

Q Cycle Activity:

If Jump:

Q1	Q2	Q3	Q4
Decode	Read literal 'n'	Process Data	Write to PC
No operation	No operation	No operation	No operation

If No Jump:

Q1	Q2	Q3	Q4
Decode	Read literal 'n'	Process Data	No operation

Example: HERE BNOV Jump

Before Instruction
PC = address (HERE)

After Instruction
If Overflow = 0;
PC = address (Jump)
If Overflow = 1;
PC = address (HERE+2)

BNZ Branch if Not Zero

Syntax: [*label*] BNZ n

Operands: $-128 \leq n \leq 127$

Operation: if Zero bit is '0'
(PC) + 2 + 2n → PC

Status Affected: None

Encoding:

1110	0001	nnnn	nnnn
------	------	------	------

Description: If the Zero bit is '0', then the program will branch. The 2's complement number '2n' is added to the PC. Since the PC will have incremented to fetch the next instruction, the new address will be PC+2+2n. This instruction is then a two-cycle instruction.

Words: 1

Cycles: 1(2)

Q Cycle Activity:

If Jump:

Q1	Q2	Q3	Q4
Decode	Read literal 'n'	Process Data	Write to PC
No operation	No operation	No operation	No operation

If No Jump:

Q1	Q2	Q3	Q4
Decode	Read literal 'n'	Process Data	No operation

Example: HERE BNZ Jump

Before Instruction
PC = address (HERE)

After Instruction
If Zero = 0;
PC = address (Jump)
If Zero = 1;
PC = address (HERE+2)

PIC18F6520/8520/6620/8620/6720/8720

BRA Unconditional Branch

Syntax: [*label*] BRA n

Operands: $-1024 \leq n \leq 1023$

Operation: $(PC) + 2 + 2n \rightarrow PC$

Status Affected: None

Encoding:

1101	0nnn	nnnn	nnnn
------	------	------	------

Description: Add the 2's complement number '2n' to the PC. Since the PC will have incremented to fetch the next instruction, the new address will be $PC+2+2n$. This instruction is a two-cycle instruction.

Words: 1

Cycles: 2

Q Cycle Activity:

Q1	Q2	Q3	Q4
Decode	Read literal 'n'	Process Data	Write to PC
No operation	No operation	No operation	No operation

Example: HERE BRA Jump

Before Instruction
PC = address (HERE)

After Instruction
PC = address (Jump)

BSF Bit Set f

Syntax: [*label*] BSF f,b[,a]

Operands: $0 \leq f \leq 255$
 $0 \leq b \leq 7$
 $a \in [0,1]$

Operation: $1 \rightarrow f < b >$

Status Affected: None

Encoding:

1000	bbba	ffff	ffff
------	------	------	------

Description: Bit 'b' in register 'f' is set. If 'a' is '0', Access Bank will be selected, overriding the BSR value. If 'a' = 1, then the bank will be selected as per the BSR value.

Words: 1

Cycles: 1

Q Cycle Activity:

Q1	Q2	Q3	Q4
Decode	Read register 'f'	Process Data	Write register 'f'

Example: BSF FLAG_REG, 7, 1

Before Instruction
FLAG_REG = 0x0A

After Instruction
FLAG_REG = 0x8A

PIC18F6520/8520/6620/8620/6720/8720

BTFSC Bit Test File, Skip if Clear

Syntax: [*label*] BTFSC f,b[,a]

Operands: $0 \leq f \leq 255$
 $0 \leq b \leq 7$
 $a \in [0,1]$

Operation: skip if (f) = 0

Status Affected: None

Encoding:

1011	bbba	ffff	ffff
------	------	------	------

Description: If bit 'b' in register 'f' is '0', then the next instruction is skipped.
 If bit 'b' is '0', then the next instruction fetched during the current instruction execution is discarded and a NOP is executed instead, making this a two-cycle instruction. If 'a' is '0', the Access Bank will be selected, overriding the BSR value. If 'a' = 1, then the bank will be selected as per the BSR value (default).

Words: 1

Cycles: 1(2)
Note: 3 cycles if skip and followed by a 2-word instruction.

Q Cycle Activity:

Q1	Q2	Q3	Q4
Decode	Read register 'f'	Process Data	No operation

If skip:

Q1	Q2	Q3	Q4
No operation	No operation	No operation	No operation

If skip and followed by 2-word instruction:

Q1	Q2	Q3	Q4
No operation	No operation	No operation	No operation
No operation	No operation	No operation	No operation

Example:
 HERE BTFSC FLAG, 1, 0
 FALSE :
 TRUE :

Before Instruction

PC = address (HERE)

After Instruction

If FLAG<1> = 0;
 PC = address (TRUE)
 If FLAG<1> = 1;
 PC = address (FALSE)

BTFSS Bit Test File, Skip if Set

Syntax: [*label*] BTFSS f,b[,a]

Operands: $0 \leq f \leq 255$
 $0 \leq b < 7$
 $a \in [0,1]$

Operation: skip if (f) = 1

Status Affected: None

Encoding:

1010	bbba	ffff	ffff
------	------	------	------

Description: If bit 'b' in register 'f' is '1', then the next instruction is skipped.
 If bit 'b' is '1', then the next instruction fetched during the current instruction execution is discarded and a NOP is executed instead, making this a two-cycle instruction. If 'a' is '0', the Access Bank will be selected, overriding the BSR value. If 'a' = 1, then the bank will be selected as per the BSR value (default).

Words: 1

Cycles: 1(2)
Note: 3 cycles if skip and followed by a 2-word instruction.

Q Cycle Activity:

Q1	Q2	Q3	Q4
Decode	Read register 'f'	Process Data	No operation

If skip:

Q1	Q2	Q3	Q4
No operation	No operation	No operation	No operation

If skip and followed by 2-word instruction:

Q1	Q2	Q3	Q4
No operation	No operation	No operation	No operation
No operation	No operation	No operation	No operation

Example:
 HERE BTFSS FLAG, 1, 0
 FALSE :
 TRUE :

Before Instruction

PC = address (HERE)

After Instruction

If FLAG<1> = 0;
 PC = address (FALSE)
 If FLAG<1> = 1;
 PC = address (TRUE)

PIC18F6520/8520/6620/8620/6720/8720

BTG **Bit Toggle f**

Syntax: [*label*] BTG f,b[,a]

Operands: $0 \leq f \leq 255$
 $0 \leq b < 7$
 $a \in [0,1]$

Operation: $(\overline{f < b}) \rightarrow f < b >$

Status Affected: None

Encoding:

0111	bbba	ffff	ffff
------	------	------	------

Description: Bit 'b' in data memory location 'f' is inverted. If 'a' is '0', the Access Bank will be selected, overriding the BSR value. If 'a' = 1, then the bank will be selected as per the BSR value (default).

Words: 1

Cycles: 1

Q Cycle Activity:

Q1	Q2	Q3	Q4
Decode	Read register 'f'	Process Data	Write register 'f'

Example: BTG PORTC, 4, 0

Before Instruction:
PORTC = 0111 0101 [0x75]

After Instruction:
PORTC = 0110 0101 [0x65]

BOV **Branch if Overflow**

Syntax: [*label*] BOV n

Operands: $-128 \leq n \leq 127$

Operation: if Overflow bit is '1'
(PC) + 2 + 2n → PC

Status Affected: None

Encoding:

1110	0100	nnnn	nnnn
------	------	------	------

Description: If the Overflow bit is '1', then the program will branch. The 2's complement number '2n' is added to the PC. Since the PC will have incremented to fetch the next instruction, the new address will be PC+2+2n. This instruction is then a two-cycle instruction.

Words: 1

Cycles: 1(2)

Q Cycle Activity:

If Jump:

Q1	Q2	Q3	Q4
Decode	Read literal 'n'	Process Data	Write to PC
No operation	No operation	No operation	No operation

If No Jump:

Q1	Q2	Q3	Q4
Decode	Read literal 'n'	Process Data	No operation

Example: HERE BOV Jump

Before Instruction
PC = address (HERE)

After Instruction
If Overflow = 1;
PC = address (Jump)
If Overflow = 0;
PC = address (HERE+2)

PIC18F6520/8520/6620/8620/6720/8720

BZ Branch if Zero

Syntax: [*label*] BZ n
 Operands: $-128 \leq n \leq 127$
 Operation: if Zero bit is '1'
 (PC) + 2 + 2n → PC

Status Affected: None

Encoding:

1110	0000	nnnn	nnnn
------	------	------	------

Description: If the Zero bit is '1', then the program will branch. The 2's complement number '2n' is added to the PC. Since the PC will have incremented to fetch the next instruction, the new address will be PC+2+2n. This instruction is then a two-cycle instruction.

Words: 1

Cycles: 1(2)

Q Cycle Activity:
 If Jump:

Q1	Q2	Q3	Q4
Decode	Read literal 'n'	Process Data	Write to PC
No operation	No operation	No operation	No operation

If No Jump:

Q1	Q2	Q3	Q4
Decode	Read literal 'n'	Process Data	No operation

Example: HERE BZ Jump

Before Instruction

PC = address (HERE)

After Instruction

If Zero = 1;
 PC = address (Jump)
 If Zero = 0;
 PC = address (HERE+2)

CALL Subroutine Call

Syntax: [*label*] CALL k [,s]

Operands: $0 \leq k \leq 1048575$
 $s \in [0,1]$

Operation: (PC) + 4 → TOS,
 k → PC<20:1>,
 if s = 1
 (W) → WS,
 (STATUS) → STATUSS,
 (BSR) → BSRS

Status Affected: None

Encoding:

1110	110s	k ₇ kkk	kkkk ₀
1111	k ₁₉ kkk	kkkk	kkkk ₈

1st word (k<7:0>)
 2nd word(k<19:8>)

Description: Subroutine call of entire 2-Mbyte memory range. First, return address (PC+ 4) is pushed onto the return stack. If 's' = 1, the W, Status and BSR registers are also pushed into their respective shadow registers, WS, STATUSS and BSRS. If 's' = 0, no update occurs (default). Then, the 20-bit value 'k' is loaded into PC<20:1>. CALL is a two-cycle instruction.

Words: 2

Cycles: 2

Q Cycle Activity:

Q1	Q2	Q3	Q4
Decode	Read literal 'k'<7:0>	Push PC to stack	Read literal 'k'<19:8>, Write to PC
No operation	No operation	No operation	No operation

Example: HERE CALL THERE, 1

Before Instruction

PC = address (HERE)

After Instruction

PC = address (THERE)
 TOS = address (HERE + 4)
 WS = W
 BSRS = BSR
 STATUSS = STATUS

PIC18F6520/8520/6620/8620/6720/8720

CLRF **Clear f**

Syntax: [*label*] CLRF f [,a]

Operands: $0 \leq f \leq 255$
 $a \in [0,1]$

Operation: $000h \rightarrow f$
 $1 \rightarrow Z$

Status Affected: Z

Encoding:

0110	101a	ffff	ffff
------	------	------	------

Description: Clears the contents of the specified register. If 'a' is '0', the Access Bank will be selected, overriding the BSR value. If 'a' = 1, then the bank will be selected as per the BSR value (default).

Words: 1

Cycles: 1

Q Cycle Activity:

Q1	Q2	Q3	Q4
Decode	Read register 'f'	Process Data	Write register 'f'

Example: CLRF FLAG_REG, 1

Before Instruction
FLAG_REG = 0x5A

After Instruction
FLAG_REG = 0x00

CLRWDT **Clear Watchdog Timer**

Syntax: [*label*] CLRWDT

Operands: None

Operation: $000h \rightarrow$ WDT,
 $000h \rightarrow$ WDT postscaler,
 $1 \rightarrow \overline{TO}$,
 $1 \rightarrow \overline{PD}$

Status Affected: \overline{TO} , \overline{PD}

Encoding:

0000	0000	0000	0100
------	------	------	------

Description: CLRWDT instruction resets the Watchdog Timer. It also resets the postscaler of the WDT. Status bits \overline{TO} and \overline{PD} are set.

Words: 1

Cycles: 1

Q Cycle Activity:

Q1	Q2	Q3	Q4
Decode	No operation	Process Data	No operation

Example: CLRWDT

Before Instruction
WDT Counter = ?

After Instruction
WDT Counter = 0x00
WDT Postscaler = 0
 \overline{TO} = 1
 \overline{PD} = 1

PIC18F6520/8520/6620/8620/6720/8720

COMF **Complement f**

Syntax: [*label*] COMF f [,d [,a]

Operands: $0 \leq f \leq 255$
 $d \in [0,1]$
 $a \in [0,1]$

Operation: $(\bar{f}) \rightarrow \text{dest}$

Status Affected: N, Z

Encoding:

0001	11da	ffff	ffff
------	------	------	------

Description: The contents of register 'f' are complemented. If 'd' is '0', the result is stored in W. If 'd' is '1', the result is stored back in register 'f' (default). If 'a' is '0', the Access Bank will be selected, overriding the BSR value. If 'a' = 1, then the bank will be selected as per the BSR value (default).

Words: 1

Cycles: 1

Q Cycle Activity:

Q1	Q2	Q3	Q4
Decode	Read register 'f'	Process Data	Write to destination

Example: COMF REG, 0, 0

Before Instruction

REG = 0x13

After Instruction

REG = 0x13

W = 0xEC

CPFSEQ **Compare f with W, skip if f = W**

Syntax: [*label*] CPFSEQ f [,a]

Operands: $0 \leq f \leq 255$
 $a \in [0,1]$

Operation: $(f) - (W)$,
skip if $(f) = (W)$
(unsigned comparison)

Status Affected: None

Encoding:

0110	001a	ffff	ffff
------	------	------	------

Description: Compares the contents of data memory location 'f' to the contents of W by performing an unsigned subtraction. If 'f' = W, then the fetched instruction is discarded and a NOP is executed instead, making this a two-cycle instruction. If 'a' is '0', the Access Bank will be selected, overriding the BSR value. If 'a' = 1, then the bank will be selected as per the BSR value (default).

Words: 1

Cycles: 1(2)

Note: 3 cycles if skip and followed by a 2-word instruction.

Q Cycle Activity:

Q1	Q2	Q3	Q4
Decode	Read register 'f'	Process Data	No operation

If skip:

Q1	Q2	Q3	Q4
No operation	No operation	No operation	No operation

If skip and followed by 2-word instruction:

Q1	Q2	Q3	Q4
No operation	No operation	No operation	No operation
No operation	No operation	No operation	No operation

Example: HERE CPFSEQ REG, 0
NEQUAL :
EQUAL :

Before Instruction

PC Address = HERE

W = ?

REG = ?

After Instruction

If REG = W;

PC = Address (EQUAL)

If REG \neq W;

PC = Address (NEQUAL)

PIC18F6520/8520/6620/8620/6720/8720

CPFSGT **Compare f with W, skip if f > W**

Syntax: [*label*] CPFSGT f [,a]

Operands: $0 \leq f \leq 255$
 $a \in [0,1]$

Operation: (f) – (W),
 skip if (f) > (W)
 (unsigned comparison)

Status Affected: None

Encoding:

0110	010a	ffff	ffff
------	------	------	------

Description: Compares the contents of data memory location 'f' to the contents of W by performing an unsigned subtraction.
 If the contents of 'f' are greater than the contents of WREG, then the fetched instruction is discarded and a NOP is executed instead, making this a two-cycle instruction. If 'a' is '0', the Access Bank will be selected, overriding the BSR value. If 'a' = 1, then the bank will be selected as per the BSR value (default).

Words: 1

Cycles: 1(2)
 Note: 3 cycles if skip and followed by a 2-word instruction.

Q Cycle Activity:

Q1	Q2	Q3	Q4
Decode	Read register 'f'	Process Data	No operation

If skip:

Q1	Q2	Q3	Q4
No operation	No operation	No operation	No operation

If skip and followed by 2-word instruction:

Q1	Q2	Q3	Q4
No operation	No operation	No operation	No operation
No operation	No operation	No operation	No operation

Example: HERE CPFSGT REG, 0
 NGREATER :
 GREATER :

Before Instruction

PC = Address (HERE)
 W = ?

After Instruction

If REG > W;
 PC = Address (GREATER)
 If REG ≤ W;
 PC = Address (NGREATER)

CPFSLT **Compare f with W, skip if f < W**

Syntax: [*label*] CPFSLT f [,a]

Operands: $0 \leq f \leq 255$
 $a \in [0,1]$

Operation: (f) – (W),
 skip if (f) < (W)
 (unsigned comparison)

Status Affected: None

Encoding:

0110	000a	ffff	ffff
------	------	------	------

Description: Compares the contents of data memory location 'f' to the contents of W by performing an unsigned subtraction.
 If the contents of 'f' are less than the contents of W, then the fetched instruction is discarded and a NOP is executed instead, making this a two-cycle instruction. If 'a' is '0', the Access Bank will be selected. If 'a' is '1', the BSR will not be overridden (default).

Words: 1

Cycles: 1(2)
 Note: 3 cycles if skip and followed by a 2-word instruction.

Q Cycle Activity:

Q1	Q2	Q3	Q4
Decode	Read register 'f'	Process Data	No operation

If skip:

Q1	Q2	Q3	Q4
No operation	No operation	No operation	No operation

If skip and followed by 2-word instruction:

Q1	Q2	Q3	Q4
No operation	No operation	No operation	No operation
No operation	No operation	No operation	No operation

Example: HERE CPFSLT REG, 1
 NLESS :
 LESS :

Before Instruction

PC = Address (HERE)
 W = ?

After Instruction

If REG < W;
 PC = Address (LESS)
 If REG ≥ W;
 PC = Address (NLESS)

PIC18F6520/8520/6620/8620/6720/8720

DAW Decimal Adjust W Register

Syntax: [*label*] DAW

Operands: None

Operation: If [W<3:0> >9] or [DC = 1] then
(W<3:0>) + 6 → W<3:0>;
else
(W<3:0>) → W<3:0>;

If [W<7:4> >9] or [C = 1] then
(W<7:4>) + 6 → W<7:4>;
else
(W<7:4>) → W<7:4>;

Status Affected: C

Encoding:

0000	0000	0000	0111
------	------	------	------

Description: DAW adjusts the eight-bit value in W, resulting from the earlier addition of two variables (each in packed BCD format) and produces a correct packed BCD result.

Words: 1

Cycles: 1

Q Cycle Activity:

Q1	Q2	Q3	Q4
Decode	Read register W	Process Data	Write W

Example 1: DAW

Before Instruction

W = 0xA5
C = 0
DC = 0

After Instruction

W = 0x05
C = 1
DC = 0

Example 2:

Before Instruction

W = 0xCE
C = 0
DC = 0

After Instruction

W = 0x34
C = 1
DC = 0

DECF Decrement f

Syntax: [*label*] DECF f [,d [,a]]

Operands: $0 \leq f \leq 255$
 $d \in [0,1]$
 $a \in [0,1]$

Operation: $(f) - 1 \rightarrow \text{dest}$

Status Affected: C, DC, N, OV, Z

Encoding:

0000	01da	ffff	ffff
------	------	------	------

Description: Decrement register 'f'. If 'd' is '0', the result is stored in W. If 'd' is '1', the result is stored back in register 'f' (default). If 'a' is '0', the Access Bank will be selected, overriding the BSR value. If 'a' = 1, then the bank will be selected as per the BSR value (default).

Words: 1

Cycles: 1

Q Cycle Activity:

Q1	Q2	Q3	Q4
Decode	Read register 'f'	Process Data	Write to destination

Example: DECF CNT, 1, 0

Before Instruction

CNT = 0x01
Z = 0

After Instruction

CNT = 0x00
Z = 1

PIC18F6520/8520/6620/8620/6720/8720

GOTO Unconditional Branch

Syntax: [*label*] GOTO *k*

Operands: $0 \leq k \leq 1048575$

Operation: $k \rightarrow PC\langle 20:1 \rangle$

Status Affected: None

Encoding:

1st word ($k\langle 7:0 \rangle$)	1110	1111	k_7kkk	$kkkk_0$
2nd word ($k\langle 19:8 \rangle$)	1111	$k_{19}kkk$	$kkkk$	$kkkk_8$

Description: GOTO allows an unconditional branch anywhere within the entire 2-Mbyte memory range. The 20-bit value 'k' is loaded into PC $\langle 20:1 \rangle$. GOTO is always a two-cycle instruction.

Words: 2

Cycles: 2

Q Cycle Activity:

Q1	Q2	Q3	Q4
Decode	Read literal 'k' $\langle 7:0 \rangle$	No operation	Read literal 'k' $\langle 19:8 \rangle$, Write to PC
No operation	No operation	No operation	No operation

Example: GOTO THERE

After Instruction
PC = Address (THERE)

INCF Increment f

Syntax: [*label*] INCF *f* [,d [,a]]

Operands: $0 \leq f \leq 255$
 $d \in [0,1]$
 $a \in [0,1]$

Operation: $(f) + 1 \rightarrow \text{dest}$

Status Affected: C, DC, N, OV, Z

Encoding:

0010	10da	ffff	ffff
------	------	------	------

Description: The contents of register 'f' are incremented. If 'd' is '0', the result is placed in W. If 'd' is '1', the result is placed back in register 'f' (default). If 'a' is '0', the Access Bank will be selected, overriding the BSR value. If 'a' = 1, then the bank will be selected as per the BSR value (default).

Words: 1

Cycles: 1

Q Cycle Activity:

Q1	Q2	Q3	Q4
Decode	Read register 'f'	Process Data	Write to destination

Example: INCF CNT, 1, 0

Before Instruction

CNT	=	0xFF
Z	=	0
C	=	?
DC	=	?

After Instruction

CNT	=	0x00
Z	=	1
C	=	1
DC	=	1

PIC18F6520/8520/6620/8620/6720/8720

INCFSZ **Increment f, skip if 0**

Syntax: [*label*] INCFSZ f [,d [,a]]

Operands: $0 \leq f \leq 255$
 $d \in [0,1]$
 $a \in [0,1]$

Operation: $(f) + 1 \rightarrow \text{dest}$,
skip if result = 0

Status Affected: None

Encoding:

0011	11da	ffff	ffff
------	------	------	------

Description: The contents of register 'f' are incremented. If 'd' is '0', the result is placed in W. If 'd' is '1', the result is placed back in register 'f' (default).
If the result is '0', the next instruction which is already fetched is discarded and a NOP is executed instead, making it a two-cycle instruction. If 'a' is '0', the Access Bank will be selected, overriding the BSR value. If 'a' = 1, then the bank will be selected as per the BSR value (default).

Words: 1

Cycles: 1(2)
Note: 3 cycles if skip and followed by a 2-word instruction.

Q Cycle Activity:

Q1	Q2	Q3	Q4
Decode	Read register 'f'	Process Data	Write to destination

If skip:

Q1	Q2	Q3	Q4
No operation	No operation	No operation	No operation

If skip and followed by 2-word instruction:

Q1	Q2	Q3	Q4
No operation	No operation	No operation	No operation
No operation	No operation	No operation	No operation

Example: HERE INCFSZ CNT, 1, 0
 NZERO :
 ZERO :

Before Instruction

PC = Address (HERE)

After Instruction

CNT = CNT + 1
If CNT = 0;
PC = Address (ZERO)
If CNT \neq 0;
PC = Address (NZERO)

INFSNZ **Increment f, skip if not 0**

Syntax: [*label*] INFSNZ f [,d [,a]]

Operands: $0 \leq f \leq 255$
 $d \in [0,1]$
 $a \in [0,1]$

Operation: $(f) + 1 \rightarrow \text{dest}$,
skip if result \neq 0

Status Affected: None

Encoding:

0100	10da	ffff	ffff
------	------	------	------

Description: The contents of register 'f' are incremented. If 'd' is '0', the result is placed in W. If 'd' is '1', the result is placed back in register 'f' (default).
If the result is not '0', the next instruction which is already fetched is discarded and a NOP is executed instead, making it a two-cycle instruction. If 'a' is '0', the Access Bank will be selected, overriding the BSR value. If 'a' = 1, then the bank will be selected as per the BSR value (default).

Words: 1

Cycles: 1(2)
Note: 3 cycles if skip and followed by a 2-word instruction.

Q Cycle Activity:

Q1	Q2	Q3	Q4
Decode	Read register 'f'	Process Data	Write to destination

If skip:

Q1	Q2	Q3	Q4
No operation	No operation	No operation	No operation

If skip and followed by 2-word instruction:

Q1	Q2	Q3	Q4
No operation	No operation	No operation	No operation
No operation	No operation	No operation	No operation

Example: HERE INFSNZ REG, 1, 0
 ZERO :
 NZERO :

Before Instruction

PC = Address (HERE)

After Instruction

REG = REG + 1
If REG \neq 0;
PC = Address (NZERO)
If REG = 0;
PC = Address (ZERO)

PIC18F6520/8520/6620/8620/6720/8720

IORLW Inclusive OR literal with W

Syntax: [*label*] IORLW *k*

Operands: $0 \leq k \leq 255$

Operation: (W) .OR. *k* → W

Status Affected: N, Z

Encoding:

0000	1001	kkkk	kkkk
------	------	------	------

Description: The contents of W are OR'ed with the eight-bit literal 'k'. The result is placed in W.

Words: 1

Cycles: 1

Q Cycle Activity:

Q1	Q2	Q3	Q4
Decode	Read literal 'k'	Process Data	Write to W

Example: IORLW 0x35

Before Instruction

W = 0x9A

After Instruction

W = 0xBF

IORWF Inclusive OR W with f

Syntax: [*label*] IORWF *f* [,d [,a]]

Operands: $0 \leq f \leq 255$

$d \in [0,1]$

$a \in [0,1]$

Operation: (W) .OR. (f) → dest

Status Affected: N, Z

Encoding:

0001	00da	ffff	ffff
------	------	------	------

Description: Inclusive OR W with register 'f'. If 'd' is '0', the result is placed in W. If 'd' is '1', the result is placed back in register 'f' (default). If 'a' is '0', the Access Bank will be selected, overriding the BSR value. If 'a' = 1, then the bank will be selected as per the BSR value (default).

Words: 1

Cycles: 1

Q Cycle Activity:

Q1	Q2	Q3	Q4
Decode	Read register 'f'	Process Data	Write to destination

Example: IORWF RESULT, 0, 1

Before Instruction

RESULT = 0x13

W = 0x91

After Instruction

RESULT = 0x13

W = 0x93

PIC18F6520/8520/6620/8620/6720/8720

LFSR **Load FSR**

Syntax: [*label*] LFSR f,k

Operands: $0 \leq f \leq 2$
 $0 \leq k \leq 4095$

Operation: $k \rightarrow \text{FSRf}$

Status Affected: None

Encoding:

1110	1110	00ff	$k_{11}kkk$
1111	0000	k_7kkk	kkkk

Description: The 12-bit literal 'k' is loaded into the File Select Register pointed to by 'f'.

Words: 2

Cycles: 2

Q Cycle Activity:

Q1	Q2	Q3	Q4
Decode	Read literal 'k' MSB	Process Data	Write literal 'k' MSB to FSRfH
Decode	Read literal 'k' LSB	Process Data	Write literal 'k' to FSRfL

Example: LFSR 2, 0x3AB

After Instruction

FSR2H = 0x03
 FSR2L = 0xAB

MOVF **Move f**

Syntax: [*label*] MOVF f [,d [,a]]

Operands: $0 \leq f \leq 255$
 $d \in [0,1]$
 $a \in [0,1]$

Operation: $f \rightarrow \text{dest}$

Status Affected: N, Z

Encoding:

0101	00da	ffff	ffff
------	------	------	------

Description: The contents of register 'f' are moved to a destination dependent upon the status of 'd'. If 'd' is '0', the result is placed in W. If 'd' is '1', the result is placed back in register 'f' (default). Location 'f' can be anywhere in the 256-byte bank. If 'a' is '0', the Access Bank will be selected, overriding the BSR value. If 'a' = 1, then the bank will be selected as per the BSR value (default).

Words: 1

Cycles: 1

Q Cycle Activity:

Q1	Q2	Q3	Q4
Decode	Read register 'f'	Process Data	Write W

Example: MOVF REG, 0, 0

Before Instruction

REG = 0x22
 W = 0xFF

After Instruction

REG = 0x22
 W = 0x22

PIC18F6520/8520/6620/8620/6720/8720

MOVFF Move f to f

Syntax: [*label*] MOVFF *f_s*,*f_d*

Operands: $0 \leq f_s \leq 4095$
 $0 \leq f_d \leq 4095$

Operation: (*f_s*) → *f_d*

Status Affected: None

Encoding:

1st word (source)	1100	ffff	ffff	ffff _s
2nd word (destin.)	1111	ffff	ffff	ffff _d

Description: The contents of source register '*f_s*' are moved to destination register '*f_d*'. Location of source '*f_s*' can be anywhere in the 4096-byte data space (000h to FFFh) and location of destination '*f_d*' can also be anywhere from 000h to FFFh. Either source or destination can be W (a useful special situation). MOVFF is particularly useful for transferring a data memory location to a peripheral register (such as the transmit buffer or an I/O port). The MOVFF instruction cannot use the PCL, TOSU, TOSH or TOSL as the destination register.

Words: 2

Cycles: 2 (3)

Q Cycle Activity:

	Q1	Q2	Q3	Q4
Decode	Decode	Read register ' <i>f</i> ' (src)	Process Data	No operation
Decode	Decode	No operation, No dummy read	No operation	Write register ' <i>f</i> ' (dest)

Example: MOVFF REG1, REG2

Before Instruction

REG1 = 0x33
 REG2 = 0x11

After Instruction

REG1 = 0x33
 REG2 = 0x33

MOVLB Move literal to low nibble in BSR

Syntax: [*label*] MOVLB *k*

Operands: $0 \leq k \leq 255$

Operation: *k* → BSR

Status Affected: None

Encoding:

0000	0001	kkkk	kkkk
------	------	------	------

Description: The 8-bit literal '*k*' is loaded into the Bank Select Register (BSR).

Words: 1

Cycles: 1

Q Cycle Activity:

Q1	Q2	Q3	Q4
Decode	Read literal ' <i>k</i> '	Process Data	Write literal ' <i>k</i> ' to BSR

Example: MOVLB 5

Before Instruction

BSR register = 0x02

After Instruction

BSR register = 0x05

PIC18F6520/8520/6620/8620/6720/8720

MOVLW Move literal to W

Syntax: [*label*] MOVLW *k*

Operands: $0 \leq k \leq 255$

Operation: $k \rightarrow W$

Status Affected: None

Encoding:

0000	1110	kkkk	kkkk
------	------	------	------

Description: The eight-bit literal 'k' is loaded into W.

Words: 1

Cycles: 1

Q Cycle Activity:

Q1	Q2	Q3	Q4
Decode	Read literal 'k'	Process Data	Write to W

Example: MOVLW 0x5A

After Instruction

W = 0x5A

MOVWF Move W to f

Syntax: [*label*] MOVWF *f* [,a]

Operands: $0 \leq f \leq 255$
 $a \in [0,1]$

Operation: $(W) \rightarrow f$

Status Affected: None

Encoding:

0110	111a	ffff	ffff
------	------	------	------

Description: Move data from W to register 'f'. Location 'f' can be anywhere in the 256-byte bank. If 'a' is '0', the Access Bank will be selected, overriding the BSR value. If 'a' = 1, then the bank will be selected as per the BSR value (default).

Words: 1

Cycles: 1

Q Cycle Activity:

Q1	Q2	Q3	Q4
Decode	Read register 'f'	Process Data	Write register 'f'

Example: MOVWF REG, 0

Before Instruction

W = 0x4F
REG = 0xFF

After Instruction

W = 0x4F
REG = 0x4F

PIC18F6520/8520/6620/8620/6720/8720

MULLW **Multiply Literal with W**

Syntax: [*label*] MULLW k

Operands: $0 \leq k \leq 255$

Operation: $(W) \times k \rightarrow \text{PRODH}:\text{PRODL}$

Status Affected: None

Encoding:

0000	1101	kkkk	kkkk
------	------	------	------

Description: An unsigned multiplication is carried out between the contents of W and the 8-bit literal 'k'. The 16-bit result is placed in PRODH:PRODL register pair. PRODH contains the high byte. W is unchanged. None of the status flags are affected. Note that neither overflow nor carry is possible in this operation. A zero result is possible but not detected.

Words: 1

Cycles: 1

Q Cycle Activity:

Q1	Q2	Q3	Q4
Decode	Read literal 'k'	Process Data	Write registers PRODH:PRODL

Example: MULLW 0xC4

Before Instruction

W = 0xE2
 PRODH = ?
 PRODL = ?

After Instruction

W = 0xE2
 PRODH = 0xAD
 PRODL = 0x08

MULWF **Multiply W with f**

Syntax: [*label*] MULWF f [,a]

Operands: $0 \leq f \leq 255$
 $a \in [0,1]$

Operation: $(W) \times (f) \rightarrow \text{PRODH}:\text{PRODL}$

Status Affected: None

Encoding:

0000	001a	ffff	ffff
------	------	------	------

Description: An unsigned multiplication is carried out between the contents of W and the register file location 'f'. The 16-bit result is stored in the PRODH:PRODL register pair. PRODH contains the high byte. Both W and 'f' are unchanged. None of the status flags are affected. Note that neither overflow nor carry is possible in this operation. A zero result is possible but not detected. If 'a' is '0', the Access Bank will be selected, overriding the BSR value. If 'a'= 1, then the bank will be selected as per the BSR value (default).

Words: 1

Cycles: 1

Q Cycle Activity:

Q1	Q2	Q3	Q4
Decode	Read register 'f'	Process Data	Write registers PRODH:PRODL

Example: MULWF REG, 1

Before Instruction

W = 0xC4
 REG = 0xB5
 PRODH = ?
 PRODL = ?

After Instruction

W = 0xC4
 REG = 0xB5
 PRODH = 0x8A
 PRODL = 0x94

PIC18F6520/8520/6620/8620/6720/8720

NEGF

Negate f

Syntax: [*label*] NEGF f [,a]

Operands: $0 \leq f \leq 255$
 $a \in [0,1]$

Operation: $(\bar{f}) + 1 \rightarrow f$

Status Affected: N, OV, C, DC, Z

Encoding:

0110	110a	ffff	ffff
------	------	------	------

Description: Location 'f' is negated using two's complement. The result is placed in the data memory location 'f'. If 'a' is '0', the Access Bank will be selected, overriding the BSR value. If 'a' = 1, then the bank will be selected as per the BSR value.

Words: 1

Cycles: 1

Q Cycle Activity:

Q1	Q2	Q3	Q4
Decode	Read register 'f'	Process Data	Write register 'f'

Example: NEGF REG, 1

Before Instruction

REG = 0011 1010 [0x3A]

After Instruction

REG = 1100 0110 [0xC6]

NOP

No Operation

Syntax: [*label*] NOP

Operands: None

Operation: No operation

Status Affected: None

Encoding:

0000	0000	0000	0000
1111	xxxx	xxxx	xxxx

Description: No operation.

Words: 1

Cycles: 1

Q Cycle Activity:

Q1	Q2	Q3	Q4
Decode	No operation	No operation	No operation

Example:

None.

PIC18F6520/8520/6620/8620/6720/8720

POP Pop Top of Return Stack

Syntax: [*label*] POP
 Operands: None
 Operation: (TOS) → bit bucket
 Status Affected: None
 Encoding:

0000	0000	0000	0110
------	------	------	------

Description: The TOS value is pulled off the return stack and is discarded. The TOS value then becomes the previous value that was pushed onto the return stack. This instruction is provided to enable the user to properly manage the return stack to incorporate a software stack.

Words: 1
 Cycles: 1

Q Cycle Activity:

Q1	Q2	Q3	Q4
Decode	No operation	POP TOS value	No operation

Example: POP GOTO NEW

Before Instruction
 TOS = 0031A2h
 Stack (1 level down) = 014332h

After Instruction
 TOS = 014332h
 PC = NEW

PUSH Push Top of Return Stack

Syntax: [*label*] PUSH
 Operands: None
 Operation: (PC+2) → TOS
 Status Affected: None
 Encoding:

0000	0000	0000	0101
------	------	------	------

Description: The PC+2 is pushed onto the top of the return stack. The previous TOS value is pushed down on the stack. This instruction allows implementing a software stack by modifying TOS and then pushing it onto the return stack.

Words: 1
 Cycles: 1

Q Cycle Activity:

Q1	Q2	Q3	Q4
Decode	PUSH PC+2 onto return stack	No operation	No operation

Example: PUSH

Before Instruction
 TOS = 00345Ah
 PC = 000124h

After Instruction
 PC = 000126h
 TOS = 000126h
 Stack (1 level down) = 00345Ah

PIC18F6520/8520/6620/8620/6720/8720

RCALL **Relative Call**

Syntax: [*label*] RCALL n

Operands: -1024 ≤ n ≤ 1023

Operation: (PC) + 2 → TOS,
 (PC) + 2 + 2n → PC

Status Affected: None

Encoding:

1101	1nnn	nnnn	nnnn
------	------	------	------

Description: Subroutine call with a jump up to 1K from the current location. First, return address (PC+2) is pushed onto the stack. Then, add the 2's complement number '2n' to the PC. Since the PC will have incremented to fetch the next instruction, the new address will be PC+2+2n. This instruction is a two-cycle instruction.

Words: 1

Cycles: 2

Q Cycle Activity:

Q1	Q2	Q3	Q4
Decode	Read literal 'n' Push PC to stack	Process Data	Write to PC
No operation	No operation	No operation	No operation

Example: HERE RCALL Jump

Before Instruction

PC = Address (HERE)

After Instruction

PC = Address (Jump)

TOS = Address (HERE+2)

RESET **Reset**

Syntax: [*label*] RESET

Operands: None

Operation: Reset all registers and flags that are affected by a MCLR Reset.

Status Affected: All

Encoding:

0000	0000	1111	1111
------	------	------	------

Description: This instruction provides a way to execute a MCLR Reset in software.

Words: 1

Cycles: 1

Q Cycle Activity:

Q1	Q2	Q3	Q4
Decode	Start Reset	No operation	No operation

Example: RESET

After Instruction

Registers = Reset Value

Flags* = Reset Value

PIC18F6520/8520/6620/8620/6720/8720

RETFIE Return from Interrupt

Syntax: [*label*] RETFIE [*s*]

Operands: $s \in [0,1]$

Operation: (TOS) → PC,
 $1 \rightarrow$ GIE/GIEH or PEIE/GIEL,
 if $s = 1$
 (WS) → W,
 (STATUS) → STATUS,
 (BSRS) → BSR,
 PCLATU, PCLATH are unchanged

Status Affected: GIE/GIEH, PEIE/GIEL.

Encoding:

0000	0000	0001	000s
------	------	------	------

Description: Return from Interrupt. Stack is popped and Top-of-Stack (TOS) is loaded into the PC. Interrupts are enabled by setting either the high or low priority global interrupt enable bit. If 's' = 1, the contents of the shadow registers, WS, STATUS and BSRS, are loaded into their corresponding registers, W, Status and BSR. If 's' = 0, no update of these registers occurs (default).

Words: 1

Cycles: 2

Q Cycle Activity:

Q1	Q2	Q3	Q4
Decode	No operation	No operation	Pop PC from stack Set GIEH or GIEL
No operation	No operation	No operation	No operation

Example: RETFIE 1

After Interrupt

PC	=	TOS
W	=	WS
BSR	=	BSRS
STATUS	=	STATUS
GIE/GIEH, PEIE/GIEL	=	1

RETLW Return Literal to W

Syntax: [*label*] RETLW *k*

Operands: $0 \leq k \leq 255$

Operation: $k \rightarrow$ W,
 (TOS) → PC,
 PCLATU, PCLATH are unchanged

Status Affected: None

Encoding:

0000	1100	kkkk	kkkk
------	------	------	------

Description: W is loaded with the eight-bit literal 'k'. The program counter is loaded from the top of the stack (the return address). The high address latch (PCLATH) remains unchanged.

Words: 1

Cycles: 2

Q Cycle Activity:

Q1	Q2	Q3	Q4
Decode	Read literal 'k'	Process Data	Pop PC from stack, Write to W
No operation	No operation	No operation	No operation

Example:

```
CALL TABLE ; W contains table
                ; offset value
                ; W now has
                ; table value
:
TABLE
ADDWF PCL ; W = offset
RETLW k0 ; Begin table
RETLW k1 ;
:
:
RETLW kn ; End of table
```

Before Instruction

W = 0x07

After Instruction

W = value of kn

PIC18F6520/8520/6620/8620/6720/8720

RETURN	Return from Subroutine												
Syntax:	[<i>label</i>] RETURN [<i>s</i>]												
Operands:	$s \in [0,1]$												
Operation:	(TOS) → PC, if $s = 1$ (WS) → W, (STATUS) → STATUS, (BSRS) → BSR, PCLATU, PCLATH are unchanged												
Status Affected:	None												
Encoding:	<table border="1"> <tr> <td>0000</td> <td>0000</td> <td>0001</td> <td>001s</td> </tr> </table>	0000	0000	0001	001s								
0000	0000	0001	001s										
Description:	Return from subroutine. The stack is popped and the top of the stack (TOS) is loaded into the program counter. If $s = 1$, the contents of the shadow registers, WS, STATUS and BSRS, are loaded into their corresponding registers, W, Status and BSR. If $s = 0$, no update of these registers occurs (default).												
Words:	1												
Cycles:	2												
Q Cycle Activity:	<table border="1"> <thead> <tr> <th>Q1</th> <th>Q2</th> <th>Q3</th> <th>Q4</th> </tr> </thead> <tbody> <tr> <td>Decode</td> <td>No operation</td> <td>Process Data</td> <td>Pop PC from stack</td> </tr> <tr> <td>No operation</td> <td>No operation</td> <td>No operation</td> <td>No operation</td> </tr> </tbody> </table>	Q1	Q2	Q3	Q4	Decode	No operation	Process Data	Pop PC from stack	No operation	No operation	No operation	No operation
Q1	Q2	Q3	Q4										
Decode	No operation	Process Data	Pop PC from stack										
No operation	No operation	No operation	No operation										

Example: RETURN
After Interrupt
PC = TOS

RLCF	Rotate Left f through Carry								
Syntax:	[<i>label</i>] RLCF f [,d [,a]								
Operands:	$0 \leq f \leq 255$ $d \in [0,1]$ $a \in [0,1]$								
Operation:	($f < n >$) → dest $<n+1 >$, ($f < 7 >$) → C, (C) → dest $<0 >$								
Status Affected:	C, N, Z								
Encoding:	<table border="1"> <tr> <td>0011</td> <td>01da</td> <td>ffff</td> <td>ffff</td> </tr> </table>	0011	01da	ffff	ffff				
0011	01da	ffff	ffff						
Description:	The contents of register 'f' are rotated one bit to the left through the Carry flag. If 'd' is '0', the result is placed in W. If 'd' is '1', the result is stored back in register 'f' (default). If 'a' is '0', the Access Bank will be selected, overriding the BSR value. If 'a' = 1, then the bank will be selected as per the BSR value (default).								
Words:	1								
Cycles:	1								
Q Cycle Activity:	<table border="1"> <thead> <tr> <th>Q1</th> <th>Q2</th> <th>Q3</th> <th>Q4</th> </tr> </thead> <tbody> <tr> <td>Decode</td> <td>Read register 'f'</td> <td>Process Data</td> <td>Write to destination</td> </tr> </tbody> </table>	Q1	Q2	Q3	Q4	Decode	Read register 'f'	Process Data	Write to destination
Q1	Q2	Q3	Q4						
Decode	Read register 'f'	Process Data	Write to destination						

Example: RLCF REG, 0, 0

Before Instruction

REG = 1110 0110
C = 0

After Instruction

REG = 1110 0110
W = 1100 1100
C = 1

PIC18F6520/8520/6620/8620/6720/8720

RLNCF Rotate Left f (no carry)

Syntax: [*label*] RLNCF f [,d [,a]

Operands: $0 \leq f \leq 255$
 $d \in [0,1]$
 $a \in [0,1]$

Operation: (f<n>) → dest<n+1>,
(f<7>) → dest<0>

Status Affected: N, Z

Encoding:

0100	01da	ffff	ffff
------	------	------	------

Description: The contents of register 'f' are rotated one bit to the left. If 'd' is '0', the result is placed in W. If 'd' is '1', the result is stored back in register 'f' (default). If 'a' is '0', the Access Bank will be selected, overriding the BSR value. If 'a' is '1', then the bank will be selected as per the BSR value (default).

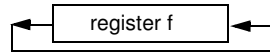

Words: 1

Cycles: 1

Q Cycle Activity:

Q1	Q2	Q3	Q4
Decode	Read register 'f'	Process Data	Write to destination

Example: RLNCF REG, 1, 0

Before Instruction

REG = 1010 1011

After Instruction

REG = 0101 0111

RRCF Rotate Right f through Carry

Syntax: [*label*] RRCF f [,d [,a]

Operands: $0 \leq f \leq 255$
 $d \in [0,1]$
 $a \in [0,1]$

Operation: (f<n>) → dest<n-1>,
(f<0>) → C,
(C) → dest<7>

Status Affected: C, N, Z

Encoding:

0011	00da	ffff	ffff
------	------	------	------

Description: The contents of register 'f' are rotated one bit to the right through the Carry flag. If 'd' is '0', the result is placed in W. If 'd' is '1', the result is placed back in register 'f' (default). If 'a' is '0', the Access Bank will be selected, overriding the BSR value. If 'a' is '1', then the bank will be selected as per the BSR value (default).

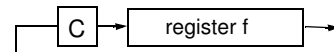

Words: 1

Cycles: 1

Q Cycle Activity:

Q1	Q2	Q3	Q4
Decode	Read register 'f'	Process Data	Write to destination

Example: RRCF REG, 0, 0

Before Instruction

REG = 1110 0110

C = 0

After Instruction

REG = 1110 0110

W = 0111 0011

C = 0

PIC18F6520/8520/6620/8620/6720/8720

RRNCF Rotate Right f (no carry)

Syntax: [*label*] RRNCF f [,d [,a]

Operands: $0 \leq f \leq 255$
 $d \in [0,1]$
 $a \in [0,1]$

Operation: $(f \leq n) \rightarrow \text{dest} \langle n-1 \rangle$,
 $(f < 0) \rightarrow \text{dest} \langle 7 \rangle$

Status Affected: N, Z

Encoding:

0100	00da	ffff	ffff
------	------	------	------

Description: The contents of register 'f' are rotated one bit to the right. If 'd' is '0', the result is placed in W. If 'd' is '1', the result is placed back in register 'f' (default). If 'a' is '0', the Access Bank will be selected, overriding the BSR value. If 'a' is '1', then the bank will be selected as per the BSR value (default).



Words: 1

Cycles: 1

Q Cycle Activity:

Q1	Q2	Q3	Q4
Decode	Read register 'f'	Process Data	Write to destination

Example 1: RRNCF REG, 1, 0

Before Instruction
REG = 1101 0111
After Instruction
REG = 1110 1011

Example 2: RRNCF REG, 0, 0

Before Instruction
W = ?
REG = 1101 0111
After Instruction
W = 1110 1011
REG = 1101 0111

SETF Set f

Syntax: [*label*] SETF f [,a]

Operands: $0 \leq f \leq 255$
 $a \in [0,1]$

Operation: FFh \rightarrow f

Status Affected: None

Encoding:

0110	100a	ffff	ffff
------	------	------	------

Description: The contents of the specified register are set to FFh. If 'a' is '0', the Access Bank will be selected, overriding the BSR value. If 'a' is '1', then the bank will be selected as per the BSR value (default).

Words: 1

Cycles: 1

Q Cycle Activity:

Q1	Q2	Q3	Q4
Decode	Read register 'f'	Process Data	Write register 'f'

Example: SETF REG, 1

Before Instruction
REG = 0x5A
After Instruction
REG = 0xFF

PIC18F6520/8520/6620/8620/6720/8720

SLEEP	Enter SLEEP mode								
Syntax:	[<i>label</i>] SLEEP								
Operands:	None								
Operation:	00h → WDT, 0 → WDT postscaler, 1 → \overline{TO} , 0 → \overline{PD}								
Status Affected:	\overline{TO} , \overline{PD}								
Encoding:	<table border="1" style="display: inline-table; border-collapse: collapse;"> <tr> <td style="padding: 2px;">0000</td> <td style="padding: 2px;">0000</td> <td style="padding: 2px;">0000</td> <td style="padding: 2px;">0011</td> </tr> </table>	0000	0000	0000	0011				
0000	0000	0000	0011						
Description:	The Power-down status bit (\overline{PD}) is cleared. The Time-out status bit (\overline{TO}) is set. Watchdog Timer and its postscaler are cleared. The processor is put into Sleep mode with the oscillator stopped.								
Words:	1								
Cycles:	1								
Q Cycle Activity:									
	<table border="1" style="display: inline-table; border-collapse: collapse;"> <tr> <th style="padding: 2px;">Q1</th> <th style="padding: 2px;">Q2</th> <th style="padding: 2px;">Q3</th> <th style="padding: 2px;">Q4</th> </tr> <tr> <td style="padding: 2px;">Decode</td> <td style="padding: 2px;">No operation</td> <td style="padding: 2px;">Process Data</td> <td style="padding: 2px;">Go to Sleep</td> </tr> </table>	Q1	Q2	Q3	Q4	Decode	No operation	Process Data	Go to Sleep
Q1	Q2	Q3	Q4						
Decode	No operation	Process Data	Go to Sleep						

Example: SLEEP

Before Instruction

\overline{TO} = ?
 \overline{PD} = ?

After Instruction

\overline{TO} = 1 †
 \overline{PD} = 0

† If WDT causes wake-up, this bit is cleared.

SUBFWB	Subtract f from W with borrow								
Syntax:	[<i>label</i>] SUBFWB f [,d [,a]								
Operands:	$0 \leq f \leq 255$ $d \in [0,1]$ $a \in [0,1]$								
Operation:	$(W) - (f) - (\overline{C}) \rightarrow \text{dest}$								
Status Affected:	N, OV, C, DC, Z								
Encoding:	<table border="1" style="display: inline-table; border-collapse: collapse;"> <tr> <td style="padding: 2px;">0101</td> <td style="padding: 2px;">01da</td> <td style="padding: 2px;">ffff</td> <td style="padding: 2px;">ffff</td> </tr> </table>	0101	01da	ffff	ffff				
0101	01da	ffff	ffff						
Description:	Subtract register 'f' and Carry flag (borrow) from W (2's complement method). If 'd' is '0', the result is stored in W. If 'd' is '1', the result is stored in register 'f' (default). If 'a' is '0', the Access Bank will be selected, overriding the BSR value. If 'a' is '1', then the bank will be selected as per the BSR value (default).								
Words:	1								
Cycles:	1								
Q Cycle Activity:									
	<table border="1" style="display: inline-table; border-collapse: collapse;"> <tr> <th style="padding: 2px;">Q1</th> <th style="padding: 2px;">Q2</th> <th style="padding: 2px;">Q3</th> <th style="padding: 2px;">Q4</th> </tr> <tr> <td style="padding: 2px;">Decode</td> <td style="padding: 2px;">Read register 'f'</td> <td style="padding: 2px;">Process Data</td> <td style="padding: 2px;">Write to destination</td> </tr> </table>	Q1	Q2	Q3	Q4	Decode	Read register 'f'	Process Data	Write to destination
Q1	Q2	Q3	Q4						
Decode	Read register 'f'	Process Data	Write to destination						

Example 1: SUBFWB REG, 1, 0

Before Instruction

REG = 3
W = 2
C = 1

After Instruction

REG = FF
W = 2
C = 0
Z = 0
N = 1 ; result is negative

Example 2: SUBFWB REG, 0, 0

Before Instruction

REG = 2
W = 5
C = 1

After Instruction

REG = 2
W = 3
C = 1
Z = 0
N = 0 ; result is positive

Example 3: SUBFWB REG, 1, 0

Before Instruction

REG = 1
W = 2
C = 0

After Instruction

REG = 0
W = 2
C = 1
Z = 1 ; result is zero
N = 0

PIC18F6520/8520/6620/8620/6720/8720

SUBLW Subtract W from literal

Syntax: [label] SUBLW k
 Operands: $0 \leq k \leq 255$
 Operation: $k - (W) \rightarrow W$
 Status Affected: N, OV, C, DC, Z
 Encoding:

0000	1000	kkkk	kkkk
------	------	------	------

 Description: W is subtracted from the eight-bit literal 'k'. The result is placed in W.
 Words: 1
 Cycles: 1
 Q Cycle Activity:

Q1	Q2	Q3	Q4
Decode	Read literal 'k'	Process Data	Write to W

Example 1: SUBLW 0x02

Before Instruction
 W = ?
 C = ?
 After Instruction
 W = 1
 C = 1 ; result is positive
 Z = 0
 N = 0

Example 2: SUBLW 0x02

Before Instruction
 W = 2
 C = ?
 After Instruction
 W = 0
 C = 1 ; result is zero
 Z = 1
 N = 0

Example 3: SUBLW 0x02

Before Instruction
 W = 3
 C = ?
 After Instruction
 W = FF ; (2's complement)
 C = 0 ; result is negative
 Z = 0
 N = 1

SUBWF Subtract W from f

Syntax: [label] SUBWF f [,d [,a]]
 Operands: $0 \leq f \leq 255$
 $d \in [0,1]$
 $a \in [0,1]$
 Operation: $(f) - (W) \rightarrow \text{dest}$
 Status Affected: N, OV, C, DC, Z
 Encoding:

0101	11da	ffff	ffff
------	------	------	------

 Description: Subtract W from register 'f' (2's complement method). If 'd' is '0', the result is stored in W. If 'd' is '1', the result is stored back in register 'f' (default). If 'a' is '0', the Access Bank will be selected, overriding the BSR value. If 'a' is '1', then the bank will be selected as per the BSR value (default).

Words: 1
 Cycles: 1

Q Cycle Activity:

Q1	Q2	Q3	Q4
Decode	Read register 'f'	Process Data	Write to destination

Example 1: SUBWF REG, 1, 0

Before Instruction
 REG = 3
 W = 2
 C = ?
 After Instruction
 REG = 1
 W = 2
 C = 1 ; result is positive
 Z = 0
 N = 0

Example 2: SUBWF REG, 0, 0

Before Instruction
 REG = 2
 W = 2
 C = ?
 After Instruction
 REG = 2
 W = 0
 C = 1 ; result is zero
 Z = 1
 N = 0

Example 3: SUBWF REG, 1, 0

Before Instruction
 REG = 1
 W = 2
 C = ?
 After Instruction
 REG = FFh ; (2's complement)
 W = 2
 C = 0 ; result is negative
 Z = 0
 N = 1

PIC18F6520/8520/6620/8620/6720/8720

SUBWFB Subtract W from f with Borrow

Syntax: [label] SUBWFB f[,d[,a]]

Operands: $0 \leq f \leq 255$
 $d \in [0,1]$
 $a \in [0,1]$

Operation: $(f) - (W) - (\bar{C}) \rightarrow \text{dest}$

Status Affected: N, OV, C, DC, Z

Encoding:

0101	10da	ffff	ffff
------	------	------	------

Description: Subtract W and the Carry flag (borrow) from register 'f' (2's complement method). If 'd' is '0', the result is stored in W. If 'd' is '1', the result is stored back in register 'f' (default). If 'a' is '0', the Access Bank will be selected, overriding the BSR value. If 'a' is '1', then the bank will be selected as per the BSR value (default).

Words: 1

Cycles: 1

Q Cycle Activity:

Q1	Q2	Q3	Q4
Decode	Read register 'f'	Process Data	Write to destination

Example 1: SUBWFB REG, 1, 0

Before Instruction

REG = 0x19 (0001 1001)
W = 0x0D (0000 1101)
C = 1

After Instruction

REG = 0x0C (0000 1011)
W = 0x0D (0000 1101)
C = 1
Z = 0
N = 0 ; result is positive

Example 2: SUBWFB REG, 0, 0

Before Instruction

REG = 0x1B (0001 1011)
W = 0x1A (0001 1010)
C = 0

After Instruction

REG = 0x1B (0001 1011)
W = 0x00
C = 1
Z = 1 ; result is zero
N = 0

Example 3: SUBWFB REG, 1, 0

Before Instruction

REG = 0x03 (0000 0011)
W = 0x0E (0000 1101)
C = 1

After Instruction

REG = 0xF5 (1111 0100)
; [2's comp]
W = 0x0E (0000 1101)
C = 0
Z = 0
N = 1 ; result is negative

SWAPF Swap f

Syntax: [label] SWAPF f[,d[,a]]

Operands: $0 \leq f \leq 255$
 $d \in [0,1]$
 $a \in [0,1]$

Operation: $(f<3:0>) \rightarrow \text{dest}<7:4>$,
 $(f<7:4>) \rightarrow \text{dest}<3:0>$

Status Affected: None

Encoding:

0011	10da	ffff	ffff
------	------	------	------

Description: The upper and lower nibbles of register 'f' are exchanged. If 'd' is '0', the result is placed in W. If 'd' is '1', the result is placed in register 'f' (default). If 'a' is '0', the Access Bank will be selected, overriding the BSR value. If 'a' is '1', then the bank will be selected as per the BSR value (default).

Words: 1

Cycles: 1

Q Cycle Activity:

Q1	Q2	Q3	Q4
Decode	Read register 'f'	Process Data	Write to destination

Example: SWAPF REG, 1, 0

Before Instruction

REG = 0x53

After Instruction

REG = 0x35

PIC18F6520/8520/6620/8620/6720/8720

TBLRD Table Read

Syntax: [*label*] TBLRD (*, *+, *-; +*)

Operands: None

Operation: if TBLRD *,
(Prog Mem (TBLPTR)) → TABLAT;
TBLPTR – No Change;
if TBLRD *+,
(Prog Mem (TBLPTR)) → TABLAT;
(TBLPTR) + 1 → TBLPTR;
if TBLRD *-,
(Prog Mem (TBLPTR)) → TABLAT;
(TBLPTR) – 1 → TBLPTR;
if TBLRD +*,
(TBLPTR) + 1 → TBLPTR;
(Prog Mem (TBLPTR)) → TABLAT;

Status Affected: None

Encoding:

0000	0000	0000	10nn nn=0 * =1 *+ =2 *- =3 +*
------	------	------	---

Description: This instruction is used to read the contents of Program Memory (P.M.). To address the Program Memory, a pointer called Table Pointer (TBLPTR) is used. The TBLPTR (a 21-bit pointer) points to each byte in the program memory. TBLPTR has a 2-Mbyte address range.

TBLPTR[0] = 0: Least Significant Byte of Program Memory Word

TBLPTR[0] = 1: Most Significant Byte of Program Memory Word

The TBLRD instruction can modify the value of TBLPTR as follows:

- no change
- post-increment
- post-decrement
- pre-increment

Words: 1

Cycles: 2

Q Cycle Activity:

	Q1	Q2	Q3	Q4
Decode	No operation	No operation	No operation	No operation
No operation	No operation (Read Program Memory)	No operation	No operation	No operation (Write TABLAT)

TBLRD Table Read (Continued)

Example 1: TBLRD *+ ;

Before Instruction

TABLAT = 0x55
TBLPTR = 0x00A356
MEMORY(0x00A356) = 0x34

After Instruction

TABLAT = 0x34
TBLPTR = 0x00A357

Example 2: TBLRD *+ ;

Before Instruction

TABLAT = 0xAA
TBLPTR = 0x01A357
MEMORY(0x01A357) = 0x12
MEMORY(0x01A358) = 0x34

After Instruction

TABLAT = 0x34
TBLPTR = 0x01A358

PIC18F6520/8520/6620/8620/6720/8720

TBLWT Table Write

Syntax: [*label*] TBLWT (*; *+; *-; +*)

Operands: None

Operation: if TBLWT*,
(TABLAT) → Holding Register;
TBLPTR – No Change;
if TBLWT*+,
(TABLAT) → Holding Register;
(TBLPTR) + 1 → TBLPTR;
if TBLWT*-,
(TABLAT) → Holding Register;
(TBLPTR) – 1 → TBLPTR;
if TBLWT*+*,
(TBLPTR) + 1 → TBLPTR;
(TABLAT) → Holding Register;

Status Affected: None

Encoding:	0000	0000	0000	11nn nn=0 * =1 *+ =2 *- =3 +*
-----------	------	------	------	---

Description: This instruction uses the 3 LSBs of TBLPTR to determine which of the 8 holding registers the TABLAT is written to. The holding registers are used to program the contents of Program Memory (P.M.). (Refer to **Section 5.0 “Flash Program Memory”** for additional details on programming Flash memory.) The TBLPTR (a 21-bit pointer) points to each byte in the Program Memory. TBLPTR has a 2-Mbyte address range. The LSb of the TBLPTR selects which byte of the program memory location to access.

TBLPTR[0] = 0: Least Significant Byte of Program Memory Word

TBLPTR[0] = 1: Most Significant Byte of Program Memory Word

The TBLWT instruction can modify the value of TBLPTR as follows:

- no change
- post-increment
- post-decrement
- pre-increment

TBLWT Table Write (Continued)

Words: 1

Cycles: 2

Q Cycle Activity:

	Q1	Q2	Q3	Q4
	Decode	No operation	No operation	No operation
	No operation	No operation (Read TABLAT)	No operation	No operation (Write to Holding Register)

Example 1: TBLWT *+;

Before Instruction

TABLAT = 0x55
TBLPTR = 0x00A356
HOLDING REGISTER (0x00A356) = 0xFF

After Instructions (table write completion)

TABLAT = 0x55
TBLPTR = 0x00A357
HOLDING REGISTER (0x00A356) = 0x55

Example 2: TBLWT +*;

Before Instruction

TABLAT = 0x34
TBLPTR = 0x01389A
HOLDING REGISTER (0x01389A) = 0xFF
HOLDING REGISTER (0x01389B) = 0xFF

After Instruction (table write completion)

TABLAT = 0x34
TBLPTR = 0x01389B
HOLDING REGISTER (0x01389A) = 0xFF
HOLDING REGISTER (0x01389B) = 0x34

PIC18F6520/8520/6620/8620/6720/8720

TSTFSZ **Test f, skip if 0**

Syntax: [*label*] TSTFSZ f [,a]

Operands: $0 \leq f \leq 255$
 $a \in [0,1]$

Operation: skip if $f = 0$

Status Affected: None

Encoding:

0110	011a	ffff	ffff
------	------	------	------

Description: If 'f' = 0, the next instruction, fetched during the current instruction execution is discarded and a NOP is executed, making this a two-cycle instruction. If 'a' is '0', the Access Bank will be selected, overriding the BSR value. If 'a' is '1', then the bank will be selected as per the BSR value (default).

Words: 1

Cycles: 1(2)
 Note: 3 cycles if skip and followed by a 2-word instruction.

Q Cycle Activity:

Q1	Q2	Q3	Q4
Decode	Read register 'f'	Process Data	No operation

If skip:

Q1	Q2	Q3	Q4
No operation	No operation	No operation	No operation

If skip and followed by 2-word instruction:

Q1	Q2	Q3	Q4
No operation	No operation	No operation	No operation
No operation	No operation	No operation	No operation

Example:

```

HERE     TSTFSZ   CNT, 1
NZERO    :
ZERO     :
```

Before Instruction

PC = Address (HERE)

After Instruction

```

If CNT    =    0x00,
PC        =    Address (ZERO)
If CNT    ≠    0x00,
PC        =    Address (NZERO)
```

XORLW **Exclusive OR literal with W**

Syntax: [*label*] XORLW k

Operands: $0 \leq k \leq 255$

Operation: (W) .XOR. k → W

Status Affected: N, Z

Encoding:

0000	1010	kkkk	kkkk
------	------	------	------

Description: The contents of W are XOR'ed with the 8-bit literal 'k'. The result is placed in W.

Words: 1

Cycles: 1

Q Cycle Activity:

Q1	Q2	Q3	Q4
Decode	Read literal 'k'	Process Data	Write to W

Example: XORLW 0xAF

Before Instruction

W = 0xB5

After Instruction

W = 0x1A

PIC18F6520/8520/6620/8620/6720/8720

XORWF Exclusive OR W with f

Syntax: [*label*] XORWF f [,d [,a]

Operands: $0 \leq f \leq 255$
 $d \in [0,1]$
 $a \in [0,1]$

Operation: (W) .XOR. (f) → dest

Status Affected: N, Z

Encoding:

0001	10da	ffff	ffff
------	------	------	------

Description: Exclusive OR the contents of W with register 'f'. If 'd' is '0', the result is stored in W. If 'd' is '1', the result is stored back in register 'f' (default). If 'a' is '0', the Access Bank will be selected, overriding the BSR value. If 'a' is '1', then the bank will be selected as per the BSR value (default).

Words: 1

Cycles: 1

Q Cycle Activity:

Q1	Q2	Q3	Q4
Decode	Read register 'f'	Process Data	Write to destination

Example: XORWF REG, 1, 0

Before Instruction

REG = 0xAF
W = 0xB5

After Instruction

REG = 0x1A
W = 0xB5

25.0 DEVELOPMENT SUPPORT

The PIC® microcontrollers and dsPIC® digital signal controllers are supported with a full range of software and hardware development tools:

- Integrated Development Environment
 - MPLAB® IDE Software
- Compilers/Assemblers/Linkers
 - MPLAB C Compiler for Various Device Families
 - HI-TECH C® for Various Device Families
 - MPASM™ Assembler
 - MPLINK™ Object Linker/
MPLIB™ Object Librarian
 - MPLAB Assembler/Linker/Librarian for Various Device Families
- Simulators
 - MPLAB SIM Software Simulator
- Emulators
 - MPLAB REAL ICE™ In-Circuit Emulator
- In-Circuit Debuggers
 - MPLAB ICD 3
 - PICKit™ 3 Debug Express
- Device Programmers
 - PICKit™ 2 Programmer
 - MPLAB PM3 Device Programmer
- Low-Cost Demonstration/Development Boards, Evaluation Kits, and Starter Kits

25.1 MPLAB Integrated Development Environment Software

The MPLAB IDE software brings an ease of software development previously unseen in the 8/16/32-bit microcontroller market. The MPLAB IDE is a Windows® operating system-based application that contains:

- A single graphical interface to all debugging tools
 - Simulator
 - Programmer (sold separately)
 - In-Circuit Emulator (sold separately)
 - In-Circuit Debugger (sold separately)
- A full-featured editor with color-coded context
- A multiple project manager
- Customizable data windows with direct edit of contents
- High-level source code debugging
- Mouse over variable inspection
- Drag and drop variables from source to watch windows
- Extensive on-line help
- Integration of select third party tools, such as IAR C Compilers

The MPLAB IDE allows you to:

- Edit your source files (either C or assembly)
- One-touch compile or assemble, and download to emulator and simulator tools (automatically updates all project information)
- Debug using:
 - Source files (C or assembly)
 - Mixed C and assembly
 - Machine code

MPLAB IDE supports multiple debugging tools in a single development paradigm, from the cost-effective simulators, through low-cost in-circuit debuggers, to full-featured emulators. This eliminates the learning curve when upgrading to tools with increased flexibility and power.

PIC18F6520/8520/6620/8620/6720/8720

25.2 MPLAB C Compilers for Various Device Families

The MPLAB C Compiler code development systems are complete ANSI C compilers for Microchip's PIC18, PIC24 and PIC32 families of microcontrollers and the dsPIC30 and dsPIC33 families of digital signal controllers. These compilers provide powerful integration capabilities, superior code optimization and ease of use.

For easy source level debugging, the compilers provide symbol information that is optimized to the MPLAB IDE debugger.

25.3 HI-TECH C for Various Device Families

The HI-TECH C Compiler code development systems are complete ANSI C compilers for Microchip's PIC family of microcontrollers and the dsPIC family of digital signal controllers. These compilers provide powerful integration capabilities, omniscient code generation and ease of use.

For easy source level debugging, the compilers provide symbol information that is optimized to the MPLAB IDE debugger.

The compilers include a macro assembler, linker, pre-processor, and one-step driver, and can run on multiple platforms.

25.4 MPASM Assembler

The MPASM Assembler is a full-featured, universal macro assembler for PIC10/12/16/18 MCUs.

The MPASM Assembler generates relocatable object files for the MPLINK Object Linker, Intel® standard HEX files, MAP files to detail memory usage and symbol reference, absolute LST files that contain source lines and generated machine code and COFF files for debugging.

The MPASM Assembler features include:

- Integration into MPLAB IDE projects
- User-defined macros to streamline assembly code
- Conditional assembly for multi-purpose source files
- Directives that allow complete control over the assembly process

25.5 MPLINK Object Linker/ MPLIB Object Librarian

The MPLINK Object Linker combines relocatable objects created by the MPASM Assembler and the MPLAB C18 C Compiler. It can link relocatable objects from precompiled libraries, using directives from a linker script.

The MPLIB Object Librarian manages the creation and modification of library files of precompiled code. When a routine from a library is called from a source file, only the modules that contain that routine will be linked in with the application. This allows large libraries to be used efficiently in many different applications.

The object linker/library features include:

- Efficient linking of single libraries instead of many smaller files
- Enhanced code maintainability by grouping related modules together
- Flexible creation of libraries with easy module listing, replacement, deletion and extraction

25.6 MPLAB Assembler, Linker and Librarian for Various Device Families

MPLAB Assembler produces relocatable machine code from symbolic assembly language for PIC24, PIC32 and dsPIC devices. MPLAB C Compiler uses the assembler to produce its object file. The assembler generates relocatable object files that can then be archived or linked with other relocatable object files and archives to create an executable file. Notable features of the assembler include:

- Support for the entire device instruction set
- Support for fixed-point and floating-point data
- Command line interface
- Rich directive set
- Flexible macro language
- MPLAB IDE compatibility

25.7 MPLAB SIM Software Simulator

The MPLAB SIM Software Simulator allows code development in a PC-hosted environment by simulating the PIC MCUs and dsPIC[®] DSCs on an instruction level. On any given instruction, the data areas can be examined or modified and stimuli can be applied from a comprehensive stimulus controller. Registers can be logged to files for further run-time analysis. The trace buffer and logic analyzer display extend the power of the simulator to record and track program execution, actions on I/O, most peripherals and internal registers.

The MPLAB SIM Software Simulator fully supports symbolic debugging using the MPLAB C Compilers, and the MPASM and MPLAB Assemblers. The software simulator offers the flexibility to develop and debug code outside of the hardware laboratory environment, making it an excellent, economical software development tool.

25.8 MPLAB REAL ICE In-Circuit Emulator System

MPLAB REAL ICE In-Circuit Emulator System is Microchip's next generation high-speed emulator for Microchip Flash DSC and MCU devices. It debugs and programs PIC[®] Flash MCUs and dsPIC[®] Flash DSCs with the easy-to-use, powerful graphical user interface of the MPLAB Integrated Development Environment (IDE), included with each kit.

The emulator is connected to the design engineer's PC using a high-speed USB 2.0 interface and is connected to the target with either a connector compatible with in-circuit debugger systems (RJ11) or with the new high-speed, noise tolerant, Low-Voltage Differential Signal (LVDS) interconnection (CAT5).

The emulator is field upgradable through future firmware downloads in MPLAB IDE. In upcoming releases of MPLAB IDE, new devices will be supported, and new features will be added. MPLAB REAL ICE offers significant advantages over competitive emulators including low-cost, full-speed emulation, run-time variable watches, trace analysis, complex breakpoints, a ruggedized probe interface and long (up to three meters) interconnection cables.

25.9 MPLAB ICD 3 In-Circuit Debugger System

MPLAB ICD 3 In-Circuit Debugger System is Microchip's most cost effective high-speed hardware debugger/programmer for Microchip Flash Digital Signal Controller (DSC) and microcontroller (MCU) devices. It debugs and programs PIC[®] Flash microcontrollers and dsPIC[®] DSCs with the powerful, yet easy-to-use graphical user interface of MPLAB Integrated Development Environment (IDE).

The MPLAB ICD 3 In-Circuit Debugger probe is connected to the design engineer's PC using a high-speed USB 2.0 interface and is connected to the target with a connector compatible with the MPLAB ICD 2 or MPLAB REAL ICE systems (RJ-11). MPLAB ICD 3 supports all MPLAB ICD 2 headers.

25.10 PICkit 3 In-Circuit Debugger/Programmer and PICkit 3 Debug Express

The MPLAB PICkit 3 allows debugging and programming of PIC[®] and dsPIC[®] Flash microcontrollers at a most affordable price point using the powerful graphical user interface of the MPLAB Integrated Development Environment (IDE). The MPLAB PICkit 3 is connected to the design engineer's PC using a full speed USB interface and can be connected to the target via an Microchip debug (RJ-11) connector (compatible with MPLAB ICD 3 and MPLAB REAL ICE). The connector uses two device I/O pins and the reset line to implement in-circuit debugging and In-Circuit Serial Programming™.

The PICkit 3 Debug Express include the PICkit 3, demo board and microcontroller, hookup cables and CDROM with user's guide, lessons, tutorial, compiler and MPLAB IDE software.

PIC18F6520/8520/6620/8620/6720/8720

25.11 PICKit 2 Development Programmer/Debugger and PICKit 2 Debug Express

The PICKit™ 2 Development Programmer/Debugger is a low-cost development tool with an easy to use interface for programming and debugging Microchip's Flash families of microcontrollers. The full featured Windows® programming interface supports baseline (PIC10F, PIC12F5xx, PIC16F5xx), midrange (PIC12F6xx, PIC16F), PIC18F, PIC24, dsPIC30, dsPIC33, and PIC32 families of 8-bit, 16-bit, and 32-bit microcontrollers, and many Microchip Serial EEPROM products. With Microchip's powerful MPLAB Integrated Development Environment (IDE) the PICKit™ 2 enables in-circuit debugging on most PIC® microcontrollers. In-Circuit-Debugging runs, halts and single steps the program while the PIC microcontroller is embedded in the application. When halted at a breakpoint, the file registers can be examined and modified.

The PICKit 2 Debug Express include the PICKit 2, demo board and microcontroller, hookup cables and CDROM with user's guide, lessons, tutorial, compiler and MPLAB IDE software.

25.12 MPLAB PM3 Device Programmer

The MPLAB PM3 Device Programmer is a universal, CE compliant device programmer with programmable voltage verification at VDDMIN and VDDMAX for maximum reliability. It features a large LCD display (128 x 64) for menus and error messages and a modular, detachable socket assembly to support various package types. The ICSP™ cable assembly is included as a standard item. In Stand-Alone mode, the MPLAB PM3 Device Programmer can read, verify and program PIC devices without a PC connection. It can also set code protection in this mode. The MPLAB PM3 connects to the host PC via an RS-232 or USB cable. The MPLAB PM3 has high-speed communications and optimized algorithms for quick programming of large memory devices and incorporates an MMC card for file storage and data applications.

25.13 Demonstration/Development Boards, Evaluation Kits, and Starter Kits

A wide variety of demonstration, development and evaluation boards for various PIC MCUs and dsPIC DSCs allows quick application development on fully functional systems. Most boards include prototyping areas for adding custom circuitry and provide application firmware and source code for examination and modification.

The boards support a variety of features, including LEDs, temperature sensors, switches, speakers, RS-232 interfaces, LCD displays, potentiometers and additional EEPROM memory.

The demonstration and development boards can be used in teaching environments, for prototyping custom circuits and for learning about various microcontroller applications.

In addition to the PICDEM™ and dsPICDEM™ demonstration/development board series of circuits, Microchip has a line of evaluation kits and demonstration software for analog filter design, KEELOQ® security ICs, CAN, IrDA®, PowerSmart battery management, SEEVAL® evaluation system, Sigma-Delta ADC, flow rate sensing, plus many more.

Also available are starter kits that contain everything needed to experience the specified device. This usually includes a single application and debug capability, all on one board.

Check the Microchip web page (www.microchip.com) for the complete list of demonstration, development and evaluation kits.

PIC18F6520/8520/6620/8620/6720/8720

26.0 ELECTRICAL CHARACTERISTICS

Absolute Maximum Ratings †)

Ambient temperature under bias	-55°C to +125°C
Storage temperature	-65°C to +150°C
Voltage on any pin with respect to VSS (except VDD, $\overline{\text{MCLR}}$ and RA4)	-0.3V to (VDD + 0.3V)
Voltage on VDD with respect to VSS	-0.3V to +5.5V
Voltage on $\overline{\text{MCLR}}$ with respect to VSS (Note 2)	0V to +13.25V
Voltage on RA4 with respect to VSS	0V to +8.5V
Total power dissipation (Note 1)	1.0W
Maximum current out of VSS pin	300 mA
Maximum current into VDD pin	250 mA
Input clamp current, I _{IK} (V _I < 0 or V _I > VDD)	±20 mA
Output clamp current, I _{OK} (V _O < 0 or V _O > VDD)	±20 mA
Maximum output current sunk by any I/O pin	25 mA
Maximum output current sourced by any I/O pin	25 mA
Maximum current sunk by all ports	200 mA
Maximum current sourced by all ports	200 mA

Note 1: Power dissipation is calculated as follows:

$$P_{dis} = VDD \times \{I_{DD} - \sum I_{OH}\} + \sum \{(VDD - V_{OH}) \times I_{OH}\} + \sum (V_{OL} \times I_{OL})$$

- 2:** Voltage spikes below VSS at the $\overline{\text{MCLR}}$ /VPP pin, inducing currents greater than 80 mA, may cause latch-up. Thus, a series resistor of 50-100Ω should be used when applying a “low” level to the $\overline{\text{MCLR}}$ /VPP pin, rather than pulling this pin directly to VSS.

† NOTICE: Stresses above those listed under “Absolute Maximum Ratings” may cause permanent damage to the device. This is a stress rating only and functional operation of the device at those or any other conditions above those indicated in the operation listings of this specification is not implied. Exposure to maximum rating conditions for extended periods may affect device reliability.

PIC18F6520/8520/6620/8620/6720/8720

FIGURE 26-1: PIC18F6520/8520 VOLTAGE-FREQUENCY GRAPH (INDUSTRIAL, EXTENDED)

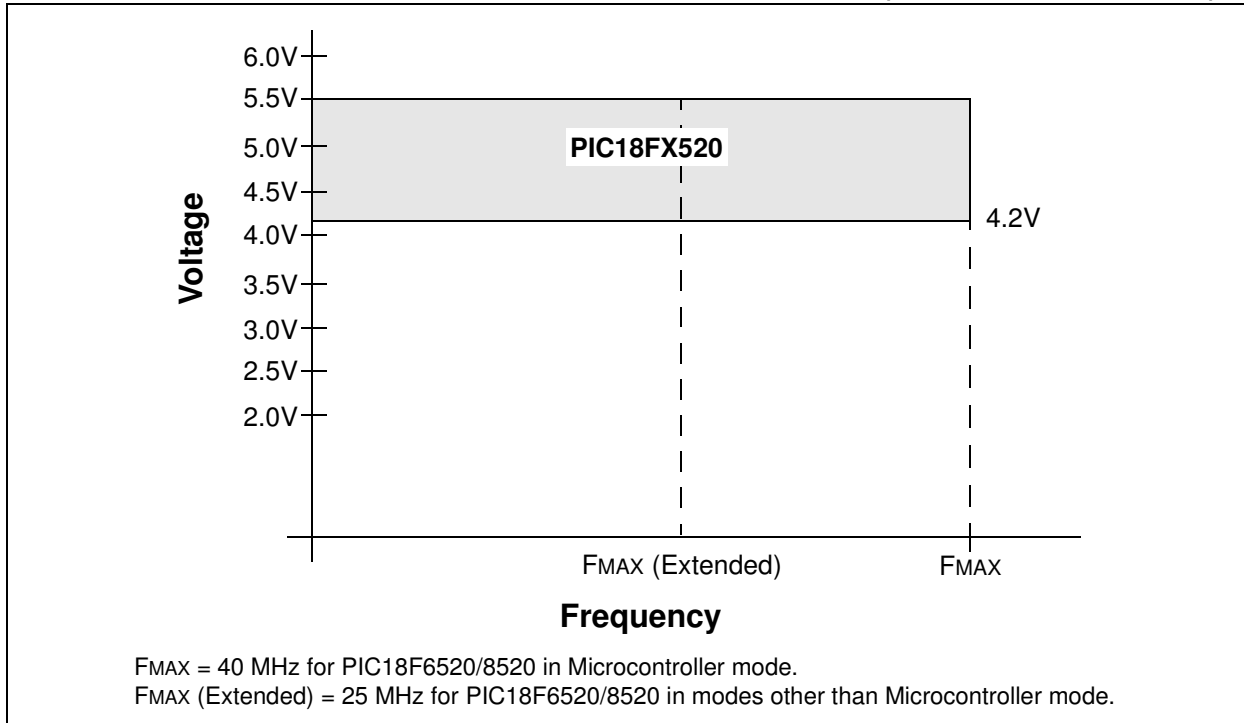
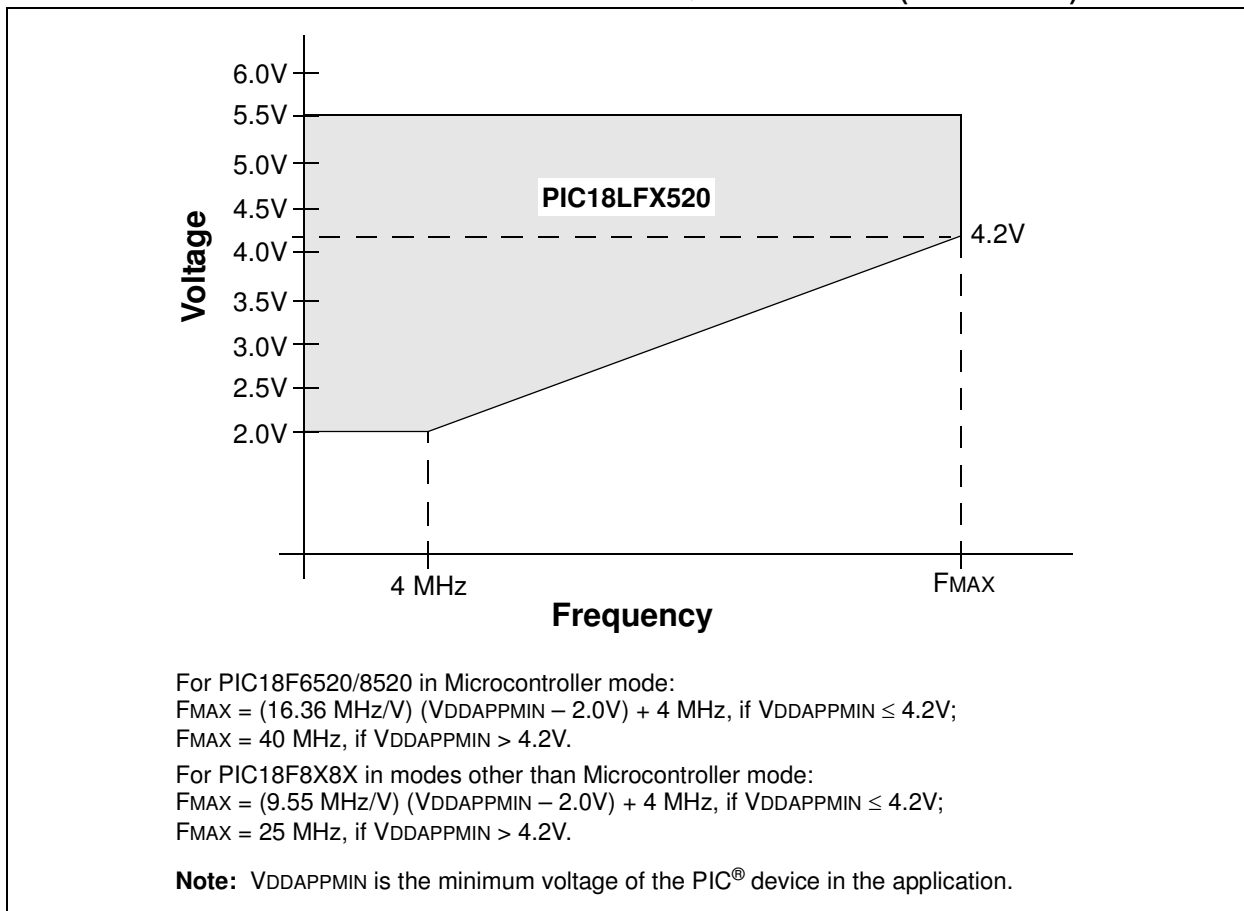

FIGURE 26-2: PIC18LF6520/8520 VOLTAGE-FREQUENCY GRAPH (INDUSTRIAL)



PIC18F6520/8520/6620/8620/6720/8720

FIGURE 26-3: PIC18F6620/6720/8620/8720 VOLTAGE-FREQUENCY GRAPH (INDUSTRIAL, EXTENDED)

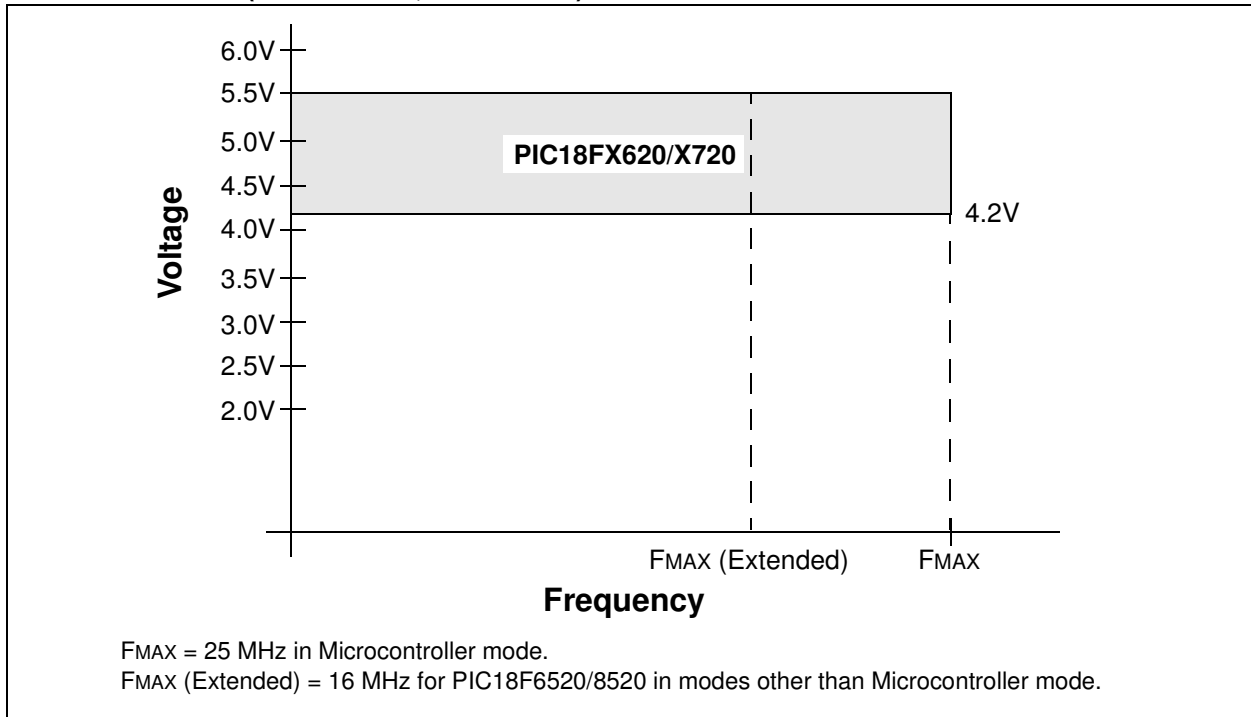
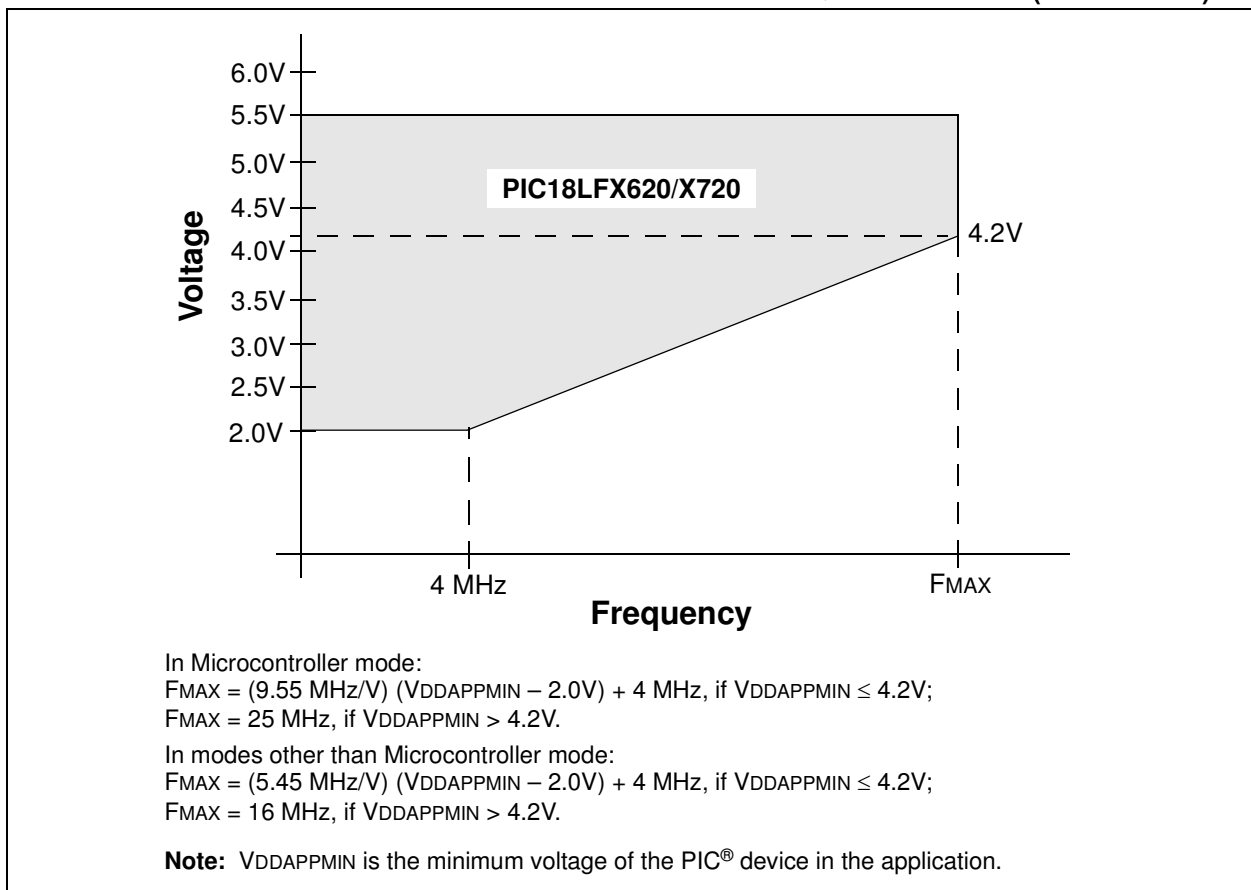

FIGURE 26-4: PIC18LF6620/6720/8620/8720 VOLTAGE-FREQUENCY GRAPH (INDUSTRIAL)



PIC18F6520/8520/6620/8620/6720/8720

26.1 DC Characteristics: Supply Voltage

PIC18F6520/8520/6620/8620/6720/8720 (Industrial, Extended)

PIC18LF6520/8520/6620/8620/6720/8720 (Industrial)

PIC18LF6520/8520/6620/8620/6720/8720 (Industrial)		Standard Operating Conditions (unless otherwise stated) Operating temperature $-40^{\circ}\text{C} \leq T_A \leq +85^{\circ}\text{C}$ for industrial					
PIC18F6520/8520/6620/8620/6720/8720 (Industrial, Extended)		Standard Operating Conditions (unless otherwise stated) Operating temperature $-40^{\circ}\text{C} \leq T_A \leq +85^{\circ}\text{C}$ for industrial $-40^{\circ}\text{C} \leq T_A \leq +125^{\circ}\text{C}$ for extended					
Param No.	Symbol	Characteristic	Min	Typ	Max	Units	Conditions
D001	VDD	Supply Voltage					
		PIC18LFXX20	2.0	—	5.5	V	HS, XT, RC and LP Oscillator mode
		PIC18FXX20	4.2	—	5.5	V	
D001A	AVDD	Analog Supply Voltage	VDD - 0.3	—	VDD + 0.3	V	
D002	VDR	RAM Data Retention Voltage⁽¹⁾	1.5	—	—	V	
D003	VPOR	VDD Start Voltage to ensure internal Power-on Reset signal	—	—	0.7	V	See section on Power-on Reset for details
D004	SVDD	VDD Rise Rate to ensure internal Power-on Reset signal	0.05	—	—	V/ms	See section on Power-on Reset for details
D005	VBOR	Brown-out Reset Voltage					
		BORV1:BORV0 = 11	N/A	—	N/A	V	Reserved
		BORV1:BORV0 = 10	2.64	—	2.92	V	
		BORV1:BORV0 = 01	4.11	—	4.55	V	
		BORV1:BORV0 = 00	4.41	—	4.87	V	

Legend: Shading of rows is to assist in readability of the table.

Note 1: This is the limit to which VDD can be lowered in Sleep mode, or during a device Reset, without losing RAM data.

PIC18F6520/8520/6620/8620/6720/8720

26.2 DC Characteristics: Power-Down and Supply Current

PIC18F6520/8520/6620/8620/6720/8720 (Industrial, Extended)
 PIC18LF6520/8520/6620/8620/6720/8720 (Industrial)

PIC18LF6520/8520/6620/8620/6720/8720 (Industrial)		Standard Operating Conditions (unless otherwise stated) Operating temperature $-40^{\circ}\text{C} \leq T_A \leq +85^{\circ}\text{C}$ for industrial			
PIC18F6520/8520/6620/8620/6720/8720 (Industrial, Extended)		Standard Operating Conditions (unless otherwise stated) Operating temperature $-40^{\circ}\text{C} \leq T_A \leq +85^{\circ}\text{C}$ for industrial $-40^{\circ}\text{C} \leq T_A \leq +125^{\circ}\text{C}$ for extended			
Param No.	Device	Typ	Max	Units	Conditions
Power-down Current (I_{PD})⁽¹⁾					
	PIC18LFXX20	0.2	1	μA	-40°C
		0.2	1	μA	+25°C
		1.2	5	μA	+85°C
	PIC18LFXX20	0.4	1	μA	-40°C
		0.4	1	μA	+25°C
		1.8	8	μA	+85°C
	All devices	0.7	2	μA	-40°C
		0.7	2	μA	+25°C
		3.0	15	μA	+85°C

Legend: Shading of rows is to assist in readability of the table.

- Note 1:** The power-down current in Sleep mode does not depend on the oscillator type. Power-down current is measured with the part in Sleep mode, with all I/O pins in high-impedance state and tied to V_{DD} or V_{SS} and all features that add delta current disabled (such as WDT, Timer1 Oscillator, BOR, etc.).
- 2:** The supply current is mainly a function of operating voltage, frequency and mode. Other factors, such as I/O pin loading and switching rate, oscillator type and circuit, internal code execution pattern and temperature, also have an impact on the current consumption.
 The test conditions for all I_{DD} measurements in active operation mode are:
 OSC1 = external square wave, from rail-to-rail; all I/O pins tri-stated, pulled to V_{DD};
 MCLR = V_{DD}; WDT enabled/disabled as specified.
- 3:** For RC oscillator configurations, current through R_{EXT} is not included. The current through the resistor can be estimated by the formula $I_r = V_{DD}/2R_{EXT}$ (mA) with R_{EXT} in kΩ.

PIC18F6520/8520/6620/8620/6720/8720

26.2 DC Characteristics: Power-Down and Supply Current

PIC18F6520/8520/6620/8620/6720/8720 (Industrial, Extended)

PIC18LF6520/8520/6620/8620/6720/8720 (Industrial) (Continued)

Param No.	Device	Typ	Max	Units	Conditions			
PIC18LF6520/8520/6620/8620/6720/8720 (Industrial)		Standard Operating Conditions (unless otherwise stated) Operating temperature $-40^{\circ}\text{C} \leq T_A \leq +85^{\circ}\text{C}$ for industrial						
PIC18F6520/8520/6620/8620/6720/8720 (Industrial, Extended)		Standard Operating Conditions (unless otherwise stated) Operating temperature $-40^{\circ}\text{C} \leq T_A \leq +85^{\circ}\text{C}$ for industrial $-40^{\circ}\text{C} \leq T_A \leq +125^{\circ}\text{C}$ for extended						
Supply Current (I_{DD})^(2,3)								
	PIC18LFXX20	165	350	μA	-40°C	$V_{DD} = 2.0\text{V}$	FOSC = 1 MHz, EC oscillator	
		165	350	μA	$+25^{\circ}\text{C}$			
		170	350	μA	$+85^{\circ}\text{C}$			
	PIC18LFXX20	360	750	μA	-40°C	$V_{DD} = 3.0\text{V}$		
		340	750	μA	$+25^{\circ}\text{C}$			
		300	750	μA	$+85^{\circ}\text{C}$			
	All devices	800	1700	μA	-40°C	$V_{DD} = 5.0\text{V}$		
		730	1700	μA	$+25^{\circ}\text{C}$			
		700	1700	μA	$+85^{\circ}\text{C}$			
	PIC18LFXX20	600	1200	μA	-40°C	$V_{DD} = 2.0\text{V}$		FOSC = 4 MHz, EC oscillator
		600	1200	μA	$+25^{\circ}\text{C}$			
		640	1300	μA	$+85^{\circ}\text{C}$			
	PIC18LFXX20	1000	2500	μA	-40°C	$V_{DD} = 3.0\text{V}$		
		1000	2500	μA	$+25^{\circ}\text{C}$			
		1000	2500	μA	$+85^{\circ}\text{C}$			
All devices	2.2	5.0	mA	-40°C	$V_{DD} = 5.0\text{V}$			
	2.1	5.0	mA	$+25^{\circ}\text{C}$				
	2.0	5.0	mA	$+85^{\circ}\text{C}$				

Legend: Shading of rows is to assist in readability of the table.

- Note 1:** The power-down current in Sleep mode does not depend on the oscillator type. Power-down current is measured with the part in Sleep mode, with all I/O pins in high-impedance state and tied to V_{DD} or V_{SS} and all features that add delta current disabled (such as WDT, Timer1 Oscillator, BOR, etc.).
- 2:** The supply current is mainly a function of operating voltage, frequency and mode. Other factors, such as I/O pin loading and switching rate, oscillator type and circuit, internal code execution pattern and temperature, also have an impact on the current consumption.
The test conditions for all I_{DD} measurements in active operation mode are:
OSC1 = external square wave, from rail-to-rail; all I/O pins tri-stated, pulled to V_{DD} ;
 $\overline{\text{MCLR}} = V_{DD}$; WDT enabled/disabled as specified.
- 3:** For RC oscillator configurations, current through R_{EXT} is not included. The current through the resistor can be estimated by the formula $I_r = V_{DD}/2R_{EXT}$ (mA) with R_{EXT} in $\text{k}\Omega$.

PIC18F6520/8520/6620/8620/6720/8720

26.2 DC Characteristics: Power-Down and Supply Current

PIC18F6520/8520/6620/8620/6720/8720 (Industrial, Extended)

PIC18LF6520/8520/6620/8620/6720/8720 (Industrial) (Continued)

Param No.	Device	Typ	Max	Units	Conditions		
PIC18LF6520/8520/6620/8620/6720/8720 (Industrial)		Standard Operating Conditions (unless otherwise stated) Operating temperature $-40^{\circ}\text{C} \leq T_A \leq +85^{\circ}\text{C}$ for industrial					
PIC18F6520/8520/6620/8620/6720/8720 (Industrial, Extended)		Standard Operating Conditions (unless otherwise stated) Operating temperature $-40^{\circ}\text{C} \leq T_A \leq +85^{\circ}\text{C}$ for industrial $-40^{\circ}\text{C} \leq T_A \leq +125^{\circ}\text{C}$ for extended					
Supply Current (I_{DD})^(2,3)							
	PIC18FX620, PIC18FX720	9.3	15	mA	-40°C	V _{DD} = 4.2V	Fosc = 25 MHz, EC oscillator
		9.5	15	mA	$+25^{\circ}\text{C}$		
		10	15	mA	$+85^{\circ}\text{C}$		
	PIC18FX620, PIC18FX720	11.8	20	mA	-40°C	V _{DD} = 5.0V	
		12	20	mA	$+25^{\circ}\text{C}$		
		12	20	mA	$+85^{\circ}\text{C}$		
	PIC18FX520	16	20	mA	-40°C	V _{DD} = 4.2V	Fosc = 40 MHz, EC oscillator
		16	20	mA	$+25^{\circ}\text{C}$		
		16	20	mA	$+85^{\circ}\text{C}$		
	PIC18FX520	19	25	mA	-40°C	V _{DD} = 5.0V	
		19	25	mA	$+25^{\circ}\text{C}$		
		19	25	mA	$+85^{\circ}\text{C}$		
D014	PIC18FX620/X720	15	55	μA	-40°C to $+85^{\circ}\text{C}$	V _{DD} = 2.0V	Fosc = 32 kHz, Timer1 as clock
	PIC18LF8520	13	18	μA	-40°C to $+85^{\circ}\text{C}$	V _{DD} = 2.0V	Fosc = 32 kHz, Timer1 as clock
		20	35	μA	-40°C to $+85^{\circ}\text{C}$	V _{DD} = 3.0V	
		50	85	μA	-40°C to $+85^{\circ}\text{C}$	V _{DD} = 5.0V	
	PIC18FXX20	—	200	μA	-40°C to $+85^{\circ}\text{C}$	V _{DD} = 4.2V	Fosc = 32 kHz, Timer1 as clock
		—	250	μA	-40°C to $+125^{\circ}\text{C}$	V _{DD} = 4.2V	

Legend: Shading of rows is to assist in readability of the table.

- Note 1:** The power-down current in Sleep mode does not depend on the oscillator type. Power-down current is measured with the part in Sleep mode, with all I/O pins in high-impedance state and tied to V_{DD} or V_{SS} and all features that add delta current disabled (such as WDT, Timer1 Oscillator, BOR, etc.).
- 2:** The supply current is mainly a function of operating voltage, frequency and mode. Other factors, such as I/O pin loading and switching rate, oscillator type and circuit, internal code execution pattern and temperature, also have an impact on the current consumption.
The test conditions for all I_{DD} measurements in active operation mode are:
OSC1 = external square wave, from rail-to-rail; all I/O pins tri-stated, pulled to V_{DD};
MCLR = V_{DD}; WDT enabled/disabled as specified.
- 3:** For RC oscillator configurations, current through R_{EXT} is not included. The current through the resistor can be estimated by the formula $I_r = V_{DD}/2R_{EXT}$ (mA) with R_{EXT} in kΩ.

PIC18F6520/8520/6620/8620/6720/8720

26.2 DC Characteristics: Power-Down and Supply Current

PIC18F6520/8520/6620/8620/6720/8720 (Industrial, Extended)

PIC18LF6520/8520/6620/8620/6720/8720 (Industrial) (Continued)

PIC18LF6520/8520/6620/8620/6720/8720 (Industrial)		Standard Operating Conditions (unless otherwise stated)					
		Operating temperature $-40^{\circ}\text{C} \leq T_A \leq +85^{\circ}\text{C}$ for industrial					
PIC18F6520/8520/6620/8620/6720/8720 (Industrial, Extended)		Standard Operating Conditions (unless otherwise stated)					
		Operating temperature $-40^{\circ}\text{C} \leq T_A \leq +85^{\circ}\text{C}$ for industrial $-40^{\circ}\text{C} \leq T_A \leq +125^{\circ}\text{C}$ for extended					
Param No.	Device	Typ	Max	Units	Conditions		
D022 (ΔIWDT)	Watchdog Timer	Module Differential Currents (ΔIWDT , ΔIBOR , ΔILVD , ΔIOSCB , ΔIAD)					
		<1	2.0	μA	-40°C	$V_{\text{DD}} = 2.0\text{V}$	
		<1	1.5	μA	$+25^{\circ}\text{C}$		
		<1	3	μA	$+85^{\circ}\text{C}$		
			3	10	μA	-40°C	$V_{\text{DD}} = 3.0\text{V}$
			2.5	6	μA	$+25^{\circ}\text{C}$	
			3	15	μA	$+85^{\circ}\text{C}$	
			15	25	μA	-40°C	$V_{\text{DD}} = 5.0\text{V}$
			12	20	μA	$+25^{\circ}\text{C}$	
			12	40	μA	$+85^{\circ}\text{C}$	
D022A (ΔIBOR)	Brown-out Reset	35	50	μA	-40°C to $+85^{\circ}\text{C}$	$V_{\text{DD}} = 3.0\text{V}$	
		45	65	μA	-40°C to $+85^{\circ}\text{C}$	$V_{\text{DD}} = 5.0\text{V}$	
D022B (ΔILVD)	Low-Voltage Detect	33	45	μA	-40°C to $+85^{\circ}\text{C}$	$V_{\text{DD}} = 2.0\text{V}$	
		35	50	μA	-40°C to $+85^{\circ}\text{C}$	$V_{\text{DD}} = 3.0\text{V}$	
		45	65	μA	-40°C to $+85^{\circ}\text{C}$	$V_{\text{DD}} = 5.0\text{V}$	
D025 (ΔIOSCB)	Timer1 Oscillator PIC18LF8720/8620	5.2	30	μA	$+25^{\circ}\text{C}$	$V_{\text{DD}} = 2.0\text{V}$	
		5.2	40	μA	-40°C to $+85^{\circ}\text{C}$	$V_{\text{DD}} = 2.0\text{V}$	
		6.5	50	μA	-40°C to $+125^{\circ}\text{C}$	$V_{\text{DD}} = 4.2\text{V}$	
		PIC18F8520/8620/8720	6.5	40	μA	$+25^{\circ}\text{C}$	$V_{\text{DD}} = 4.2\text{V}$
			6.5	50	μA	-40°C to $+85^{\circ}\text{C}$	
			6.5	65	μA	-40°C to $+125^{\circ}\text{C}$	
		PIC18LF8520	1.8	2.2	μA	$+25^{\circ}\text{C}$	$V_{\text{DD}} = 2.0\text{V}$
			2.9	3.8	μA	-40°C to $+85^{\circ}\text{C}$	
			3.4	7.0	μA	-40°C to $+125^{\circ}\text{C}$	
D026 (ΔIAD)	A/D Converter	<1	2	μA	$+25^{\circ}\text{C}$	$V_{\text{DD}} = 2.0\text{V}$	
		<1	2	μA	$+25^{\circ}\text{C}$		
		<1	2	μA	$+25^{\circ}\text{C}$		

Legend: Shading of rows is to assist in readability of the table.

- Note 1:** The power-down current in Sleep mode does not depend on the oscillator type. Power-down current is measured with the part in Sleep mode, with all I/O pins in high-impedance state and tied to V_{DD} or V_{SS} and all features that add delta current disabled (such as WDT, Timer1 Oscillator, BOR, etc.).
- 2:** The supply current is mainly a function of operating voltage, frequency and mode. Other factors, such as I/O pin loading and switching rate, oscillator type and circuit, internal code execution pattern and temperature, also have an impact on the current consumption.
The test conditions for all I_{DD} measurements in active operation mode are:
OSC1 = external square wave, from rail-to-rail; all I/O pins tri-stated, pulled to V_{DD} ;
MCLR = V_{DD} ; WDT enabled/disabled as specified.
- 3:** For RC oscillator configurations, current through REXT is not included. The current through the resistor can be estimated by the formula $I_r = V_{\text{DD}}/2\text{REXT}$ (mA) with REXT in $\text{k}\Omega$.

PIC18F6520/8520/6620/8620/6720/8720

26.3 DC Characteristics: PIC18F6520/8520/6620/8620/6720/8720 (Industrial, Extended) PIC18LF6520/8520/6620/8620/6720/8720 (Industrial)

DC CHARACTERISTICS			Standard Operating Conditions (unless otherwise stated) Operating temperature $-40^{\circ}\text{C} \leq T_A \leq +85^{\circ}\text{C}$ for industrial $-40^{\circ}\text{C} \leq T_A \leq +125^{\circ}\text{C}$ for extended			
Param No.	Sym	Characteristic	Min	Max	Units	Conditions
D030 D030A D031 D032 D032A D033	V_{IL}	Input Low Voltage I/O ports: with TTL buffer with Schmitt Trigger buffer RC3 and RC4 $\overline{\text{MCLR}}$ OSC1 (in XT, HS and LP modes) and T1OSI OSC1 (in RC and EC mode) ⁽¹⁾	V_{SS} — V_{SS} V_{SS} V_{SS} V_{SS}	$0.15 V_{DD}$ 0.8 $0.2 V_{DD}$ $0.3 V_{DD}$ $0.2 V_{DD}$ $0.2 V_{DD}$	V V V V V V	$V_{DD} < 4.5\text{V}$ $4.5\text{V} \leq V_{DD} \leq 5.5\text{V}$
D040 D040A D041 D042 D042A D043	V_{IH}	Input High Voltage I/O ports: with TTL buffer with Schmitt Trigger buffer RC3 and RC4 $\overline{\text{MCLR}}$, OSC1 (EC mode) OSC1 and T1OSI OSC1 (RC mode) ⁽¹⁾	$0.25 V_{DD} + 0.8\text{V}$ 2.0 $0.8 V_{DD}$ $0.7 V_{DD}$ $0.8 V_{DD}$ 1.6 $0.9 V_{DD}$	V_{DD} V_{DD} V_{DD} V_{DD} V_{DD} V_{DD} V_{DD}	V V V V V V V	$V_{DD} < 4.5\text{V}$ $4.5\text{V} \leq V_{DD} \leq 5.5\text{V}$ LP, XT, HS, HSPLL modes ⁽¹⁾
D060 D061 D063	I_{IL}	Input Leakage Current^(2,3) I/O ports $\overline{\text{MCLR}}$ OSC1	— — —	± 1 ± 5 ± 5	μA μA μA	$V_{SS} \leq V_{PIN} \leq V_{DD}$, Pin at high-impedance $V_{SS} \leq V_{PIN} \leq V_{DD}$ $V_{SS} \leq V_{PIN} \leq V_{DD}$
D070	IPU IPURB	Weak Pull-up Current PORTB weak pull-up current	50	400	μA	$V_{DD} = 5\text{V}$, $V_{PIN} = V_{SS}$

Note 1: In RC oscillator configuration, the OSC1/CLKI pin is a Schmitt Trigger input. It is not recommended that the PIC device be driven with an external clock while in RC mode.

2: The leakage current on the $\overline{\text{MCLR}}$ pin is strongly dependent on the applied voltage level. The specified levels represent normal operating conditions. Higher leakage current may be measured at different input voltages.

3: Negative current is defined as current sourced by the pin.

4: Parameter is characterized but not tested.

PIC18F6520/8520/6620/8620/6720/8720

26.3 DC Characteristics: PIC18F6520/8520/6620/8620/6720/8720 (Industrial, Extended) PIC18LF6520/8520/6620/8620/6720/8720 (Industrial) (Continued)

DC CHARACTERISTICS			Standard Operating Conditions (unless otherwise stated) Operating temperature $-40^{\circ}\text{C} \leq T_A \leq +85^{\circ}\text{C}$ for industrial $-40^{\circ}\text{C} \leq T_A \leq +125^{\circ}\text{C}$ for extended			
Param No.	Sym	Characteristic	Min	Max	Units	Conditions
D080	VOL	Output Low Voltage I/O ports	—	0.6	V	$I_{OL} = 8.5\text{ mA}$, $V_{DD} = 4.5\text{V}$, -40°C to $+85^{\circ}\text{C}$
D080A			—	0.6	V	$I_{OL} = 7.0\text{ mA}$, $V_{DD} = 4.5\text{V}$, -40°C to $+125^{\circ}\text{C}$
D083		OSC2/CLKO (RC mode)	—	0.6	V	$I_{OL} = 1.6\text{ mA}$, $V_{DD} = 4.5\text{V}$, -40°C to $+85^{\circ}\text{C}$
D083A			—	0.6	V	$I_{OL} = 1.2\text{ mA}$, $V_{DD} = 4.5\text{V}$, -40°C to $+125^{\circ}\text{C}$
D090	VOH	Output High Voltage⁽³⁾ I/O ports	$V_{DD} - 0.7$	—	V	$I_{OH} = -3.0\text{ mA}$, $V_{DD} = 4.5\text{V}$, -40°C to $+85^{\circ}\text{C}$
D090A			$V_{DD} - 0.7$	—	V	$I_{OH} = -2.5\text{ mA}$, $V_{DD} = 4.5\text{V}$, -40°C to $+125^{\circ}\text{C}$
D092		OSC2/CLKO (RC mode)	$V_{DD} - 0.7$	—	V	$I_{OH} = -1.3\text{ mA}$, $V_{DD} = 4.5\text{V}$, -40°C to $+85^{\circ}\text{C}$
D092A			$V_{DD} - 0.7$	—	V	$I_{OH} = -1.0\text{ mA}$, $V_{DD} = 4.5\text{V}$, -40°C to $+125^{\circ}\text{C}$
D150	VOD	Open-Drain High Voltage	—	8.5	V	RA4 pin
		Capacitive Loading Specs on Output Pins				
D100 ⁽⁴⁾	Cosc2	OSC2 pin	—	15	pF	In XT, HS and LP modes when external clock is used to drive OSC1
D101	Cio	All I/O pins and OSC2 (in RC mode)	—	50	pF	To meet the AC Timing Specifications
D102	CB	SCL, SDA	—	400	pF	In I ² C mode

Note 1: In RC oscillator configuration, the OSC1/CLKI pin is a Schmitt Trigger input. It is not recommended that the PIC device be driven with an external clock while in RC mode.

2: The leakage current on the $\overline{\text{MCLR}}$ pin is strongly dependent on the applied voltage level. The specified levels represent normal operating conditions. Higher leakage current may be measured at different input voltages.

3: Negative current is defined as current sourced by the pin.

4: Parameter is characterized but not tested.

PIC18F6520/8520/6620/8620/6720/8720

TABLE 26-1: COMPARATOR SPECIFICATIONS

Operating Conditions: $3.0V < V_{DD} < 5.5V$, $-40^{\circ}C < T_A < +125^{\circ}C$ (unless otherwise stated).							
Param No.	Sym	Characteristics	Min	Typ	Max	Units	Comments
D300	V _{IOFF}	Input Offset Voltage	—	± 5.0	± 10	mV	
D301	V _{ICM}	Input Common Mode Voltage	0	—	$V_{DD} - 1.5$	V	
D302	CMRR	Common Mode Rejection Ratio	55	—	—	dB	
300 300A	T _{RESP}	Response Time ⁽¹⁾	—	150	400 600	ns ns	PIC18FXX20 PIC18LFXX20
301	T _{MC2OV}	Comparator Mode Change to Output Valid	—	—	10	μs	

Note 1: Response time measured with one comparator input at $(V_{DD} - 1.5)/2$, while the other input transitions from V_{SS} to V_{DD}.

TABLE 26-2: VOLTAGE REFERENCE SPECIFICATIONS

Operating Conditions: $3.0V < V_{DD} < 5.5V$, $-40^{\circ}C < T_A < +125^{\circ}C$ (unless otherwise stated).							
Param No.	Sym	Characteristics	Min	Typ	Max	Units	Comments
D310	V _{RES}	Resolution	$V_{DD}/24$	—	$V_{DD}/32$	LSb	
D311	V _{RAA}	Absolute Accuracy	— —	— —	1/4 1/2	LSb LSb	Low Range (VRR = 1) High Range (VRR = 0)
D312	V _{RUR}	Unit Resistor Value (R)	—	2k	—	Ω	
310	T _{SET}	Settling Time ⁽¹⁾	—	—	10	μs	

Note 1: Settling time measured while VRR = 1 and VR<3:0> transitions from '0000' to '1111'.

PIC18F6520/8520/6620/8620/6720/8720

FIGURE 26-5: LOW-VOLTAGE DETECT CHARACTERISTICS

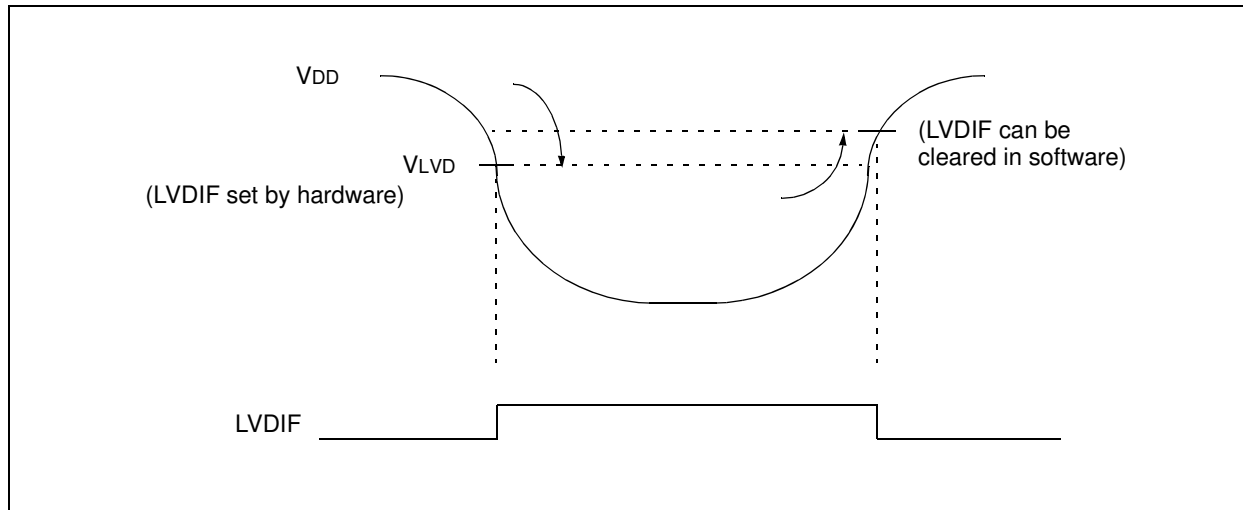

TABLE 26-3: LOW-VOLTAGE DETECT CHARACTERISTICS

Standard Operating Conditions (unless otherwise stated)								
Operating temperature $-40^{\circ}\text{C} \leq T_A \leq +85^{\circ}\text{C}$ for industrial								
$-40^{\circ}\text{C} \leq T_A \leq +125^{\circ}\text{C}$ for extended								
Param No.	Symbol	Characteristic		Min	Typ†	Max	Units	Conditions
D420		LVD Voltage on VDD Transition high-to-low	LVV = 0001	1.96	2.06	2.16	V	
			LVV = 0010	2.16	2.27	2.38	V	
			LVV = 0011	2.35	2.47	2.59	V	
			LVV = 0100	2.45	2.58	2.71	V	
			LVV = 0101	2.64	2.78	2.92	V	
			LVV = 0110	2.75	2.89	3.03	V	
			LVV = 0111	2.95	3.1	3.26	V	
			LVV = 1000	3.24	3.41	3.58	V	
			LVV = 1001	3.43	3.61	3.79	V	
			LVV = 1010	3.53	3.72	3.91	V	
			LVV = 1011	3.72	3.92	4.12	V	
			LVV = 1100	3.92	4.13	4.34	V	
			LVV = 1101	4.11	4.33	4.55	V	
LVV = 1110	4.41	4.64	4.87	V				
D423	VBG	Band Gap Reference Voltage Value		—	1.22	—	V	

† Production tested at $T_{AMB} = 25^{\circ}\text{C}$. Specifications over temperature limits ensured by characterization.

PIC18F6520/8520/6620/8620/6720/8720

TABLE 26-4: MEMORY PROGRAMMING REQUIREMENTS

DC Characteristics			Standard Operating Conditions (unless otherwise stated) Operating temperature $-40^{\circ}\text{C} \leq T_A \leq +85^{\circ}\text{C}$ for industrial $-40^{\circ}\text{C} \leq T_A \leq +125^{\circ}\text{C}$ for extended				
Param No.	Sym	Characteristic	Min	Typ†	Max	Units	Conditions
Internal Program Memory Programming Specifications (Note 1)							
D110	VPP	Voltage on $\overline{\text{MCLR}}/\text{VPP}$ pin	9.00	—	13.25	V	(Note 2)
D112	IPP	Current into $\overline{\text{MCLR}}/\text{VPP}$ pin	—	—	5	μA	
D113	IDDP	Supply Current during Programming	—	—	10	mA	
Data EEPROM Memory							
D120	ED	Cell Endurance	100K	1M	—	E/W	-40°C to $+85^{\circ}\text{C}$
D120A	ED	Cell Endurance	10K	100K	—	E/W	$+85^{\circ}\text{C}$ to $+125^{\circ}\text{C}$
D121	VDRW	VDD for Read/Write	V _{MIN}	—	5.5	V	Using EECON to read/write V _{MIN} = Minimum operating voltage
D122	TDEW	Erase/Write Cycle Time	—	4	—	ms	
D123	TRETD	Characteristic Retention	40	—	—	Year	-40°C to $+85^{\circ}\text{C}$ (Note 3)
D123A	TRETD	Characteristic Retention	100	—	—	Year	25°C (Note 3)
Program Flash Memory							
D130	EP	Cell Endurance	10K	100K	—	E/W	-40°C to $+85^{\circ}\text{C}$
D130A	EP	Cell Endurance	1000	10K	—	E/W	$+85^{\circ}\text{C}$ to $+125^{\circ}\text{C}$
D131	VPR	VDD for Read	V _{MIN}	—	5.5	V	V _{MIN} = Minimum operating voltage
D132	VIE	VDD for Block Erase	4.5	—	5.5	V	Using ICSP port
D132A	VIW	VDD for Externally Timed Erase or Write	4.5	—	5.5	V	Using ICSP port
D132B	VPEW	VDD for Self-Timed Write	V _{MIN}	—	5.5	V	V _{MIN} = Minimum operating voltage
D133	TIE	ICSP Block Erase Cycle Time	—	5	—	ms	V _{DD} > 4.5V
D133A	TIW	ICSP Erase or Write Cycle Time (externally timed)	1	—	—	ms	V _{DD} > 4.5V
D133A	TIW	Self-Timed Write Cycle Time	—	2.5	—	ms	
D134	TRETD	Characteristic Retention	40	—	—	Year	-40°C to $+85^{\circ}\text{C}$ (Note 3)
D134A	TRETD	Characteristic Retention	100	—	—	Year	25°C (Note 3)

† Data in "Typ" column is at 5.0V, 25°C unless otherwise stated. These parameters are for design guidance only and are not tested.

Note 1: These specifications are for programming the on-chip program memory through the use of table write instructions.

2: The pin may be kept in this range at times other than programming, but it is not recommended.

3: Retention time is valid, provided no other specifications are violated.

PIC18F6520/8520/6620/8620/6720/8720

26.4 AC (Timing) Characteristics

26.4.1 TIMING PARAMETER SYMBOLOGY

The timing parameter symbols have been created using one of the following formats:

1. TppS2ppS
2. TppS
3. TCC:ST (I²C specifications only)
4. Ts (I²C specifications only)

<p>T</p> <p>F Frequency</p>	<p>T</p> <p>Time</p>
----------------------------------	----------------------

Lowercase letters (pp) and their meanings:

<p>pp</p> <p>cc CCP1</p> <p>ck CLKO</p> <p>cs \overline{CS}</p> <p>di SDI</p> <p>do SDO</p> <p>dt Data in</p> <p>io I/O port</p> <p>mc \overline{MCLR}</p>	<p>osc OSC1</p> <p>rd \overline{RD}</p> <p>rw \overline{RD} or \overline{WR}</p> <p>sc SCK</p> <p>ss \overline{SS}</p> <p>t0 T0CKI</p> <p>t1 T1CKI</p> <p>wr \overline{WR}</p>
--	---

Uppercase letters and their meanings:

<p>S</p> <p>F Fall</p> <p>H High</p> <p>I Invalid (High-Impedance)</p> <p>L Low</p> <p>I²C only</p> <p>AA output access</p> <p>BUF Bus free</p>	<p>P Period</p> <p>R Rise</p> <p>V Valid</p> <p>Z High-Impedance</p> <p>High High</p> <p>Low Low</p>
--	--

TCC:ST (I²C specifications only)

<p>CC</p> <p>HD Hold</p> <p>ST</p> <p>DAT DATA input hold</p> <p>STA Start condition</p>	<p>SU Setup</p> <p>STO Stop condition</p>
---	--

PIC18F6520/8520/6620/8620/6720/8720

26.4.2 TIMING CONDITIONS

The temperature and voltages specified in Table 26-5 apply to all timing specifications unless otherwise noted. Figure 26-6 specifies the load conditions for the timing specifications.

TABLE 26-5: TEMPERATURE AND VOLTAGE SPECIFICATIONS – AC

AC CHARACTERISTICS	Standard Operating Conditions (unless otherwise stated)	
	Operating temperature	-40°C ≤ TA ≤ +85°C for industrial -40°C ≤ TA ≤ +125°C for extended
	Operating voltage VDD range	as described in DC spec Section 26.1 and Section 26.3 .
	LC parts operate	for industrial temperatures only.

FIGURE 26-6: LOAD CONDITIONS FOR DEVICE TIMING SPECIFICATIONS

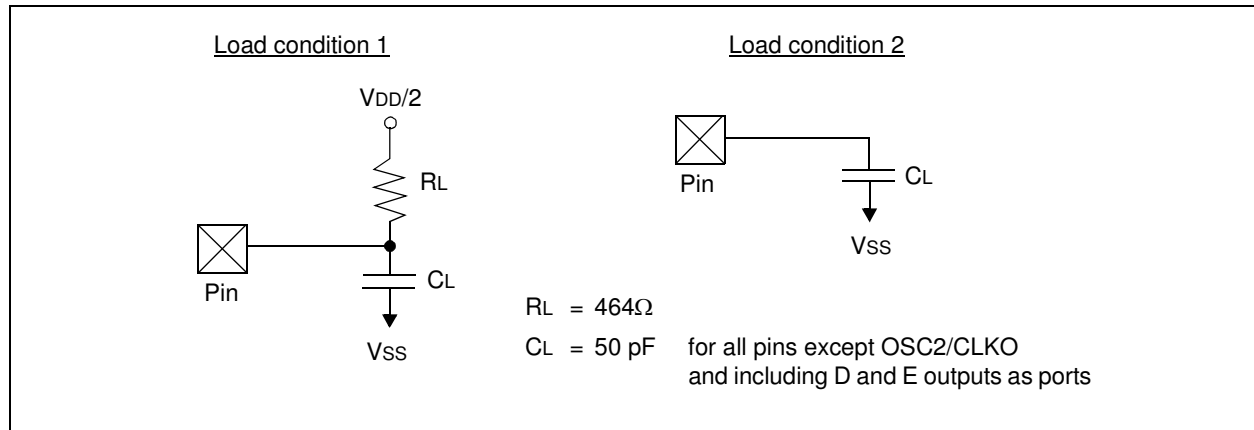

PIC18F6520/8520/6620/8620/6720/8720

26.4.3 TIMING DIAGRAMS AND SPECIFICATIONS

FIGURE 26-7: EXTERNAL CLOCK TIMING (ALL MODES EXCEPT PLL)

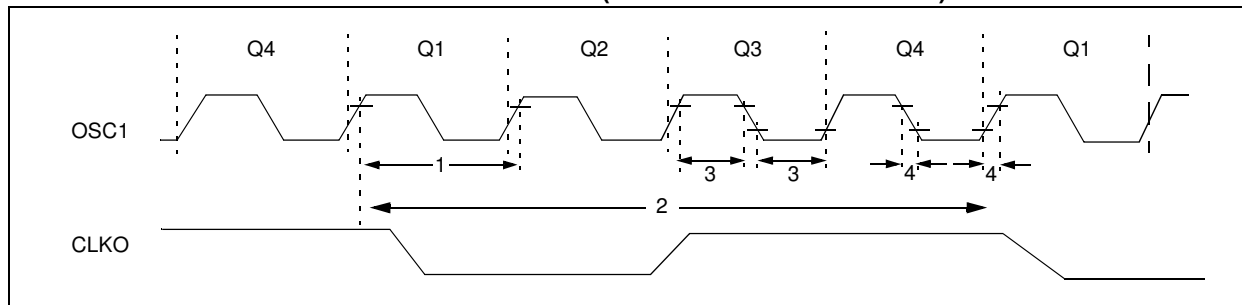

TABLE 26-6: EXTERNAL CLOCK TIMING REQUIREMENTS

Param No.	Symbol	Characteristic	Min	Max	Units	Conditions
1A	Fosc	External CLKI Frequency ⁽¹⁾	DC	25	MHz	EC, ECIO, PIC18FX620/X720 (-40°C to +85°C)
			DC	40	MHz	EC, ECIO, PIC18FX520 (-40°C to +85°C)
			DC	25	MHz	EC, ECIO, PIC18FX520 using external memory interface (-40°C to +85°C)
		Oscillator Frequency ⁽¹⁾	DC	4	MHz	RC oscillator
			0.1	4	MHz	XT oscillator
			4	25	MHz	HS oscillator
			4	10	MHz	HS + PLL oscillator, PIC18FX520
			6	6.25	MHz	HS + PLL oscillator, PIC18FX520 using external memory interface
			4	6.25	MHz	HS + PLL oscillator, PIC18FX620/X720
1	Tosc	External CLKI Period ⁽¹⁾	25	—	ns	EC, ECIO, PIC18FX620/X720 (-40°C to +85°C)
			160	—	ns	EC, ECIO, PIC18FX520 (-40°C to +85°C)
		Oscillator Period ⁽¹⁾	250	—	ns	RC oscillator
			250	10,000	ns	XT oscillator
			25	250	ns	HS oscillator
			100	250	ns	HS + PLL oscillator, PIC18FX520
			100	160	ns	HS + PLL oscillator, PIC18FX620/X720
25	—	μs	LP oscillator			
2	Tcy	Instruction Cycle Time ⁽¹⁾	100	—	ns	Tcy = 4/Fosc
3	TosL, TosH	External Clock in (OSC1) High or Low Time	30	—	ns	XT oscillator
			2.5	—	μs	LP oscillator
			10	—	ns	HS oscillator
4	TosR, TosF	External Clock in (OSC1) Rise or Fall Time	—	20	ns	XT oscillator
			—	50	ns	LP oscillator
			—	7.5	ns	HS oscillator

Note 1: Instruction cycle period (Tcy) equals four times the input oscillator time base period for all configurations except PLL. All specified values are based on characterization data for that particular oscillator type under standard operating conditions with the device executing code. Exceeding these specified limits may result in an unstable oscillator operation and/or higher than expected current consumption. All devices are tested to operate at “min.” values with an external clock applied to the OSC1/CLKI pin. When an external clock input is used, the “max.” cycle time limit is “DC” (no clock) for all devices.

PIC18F6520/8520/6620/8620/6720/8720

TABLE 26-7: PLL CLOCK TIMING SPECIFICATIONS (V_{DD} = 4.2V TO 5.5V)

Param No.	Sym	Characteristic	Min	Typ†	Max	Units	Conditions
—	FOSC	Oscillator Frequency Range	4	—	10	MHz	HS mode
—	F _{SYS}	On-Chip VCO System Frequency	16	—	40	MHz	HS mode
—	t _{rc}	PLL Start-up Time (Lock Time)	—	—	2	ms	
—	ΔCLK	CLKO Stability (Jitter)	-2	—	+2	%	

† Data in "Typ" column is at 5V, 25°C, unless otherwise stated. These parameters are for design guidance only and are not tested.

FIGURE 26-8: CLKO AND I/O TIMING

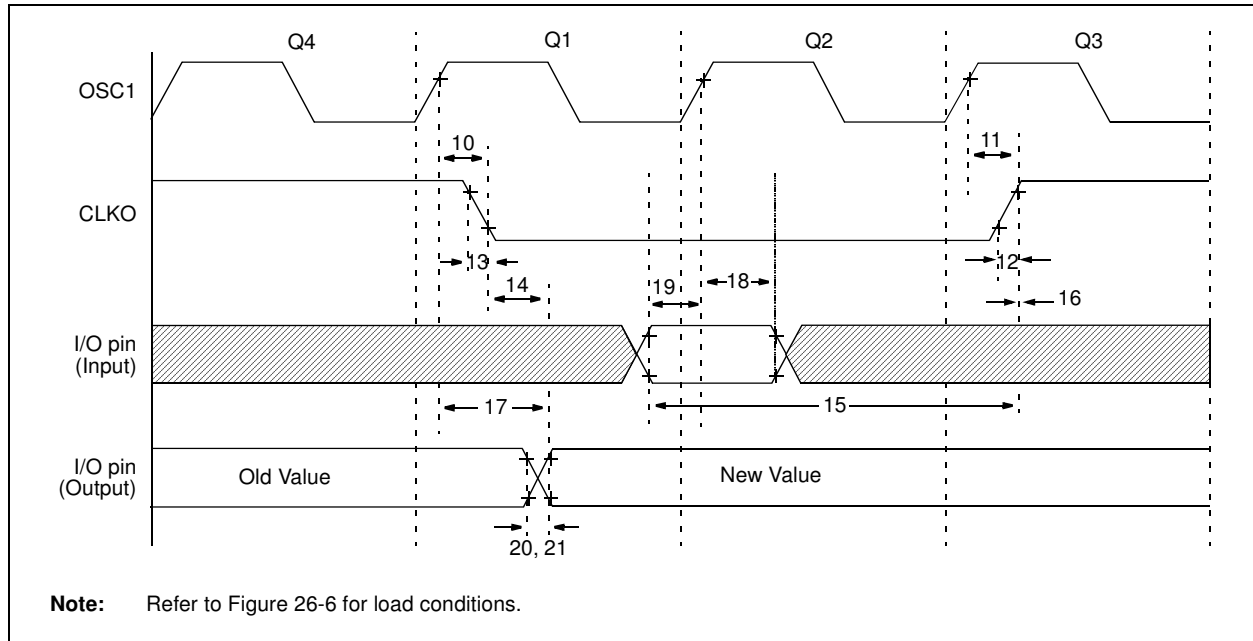

PIC18F6520/8520/6620/8620/6720/8720

TABLE 26-8: CLKO AND I/O TIMING REQUIREMENTS

Param No.	Symbol	Characteristic	Min	Typ	Max	Units	Conditions	
10	TosH2ckL	OSC1 ↑ to CLKO ↓	—	75	200	ns	(Note 1)	
11	TosH2ckH	OSC1 ↑ to CLKO ↑	—	75	200	ns	(Note 1)	
12	TckR	CLKO Rise Time	—	35	100	ns	(Note 1)	
13	TckF	CLKO Fall Time	—	35	100	ns	(Note 1)	
14	TckL2ioV	CLKO ↓ to Port Out Valid	—	—	0.5 T _{CY} + 20	ns	(Note 1)	
15	TioV2ckH	Port In Valid before CLKO ↑	0.25 T _{CY} + 25	—	—	ns	(Note 1)	
16	TckH2ioI	Port In Hold after CLKO ↑	0	—	—	ns	(Note 1)	
17	TosH2ioV	OSC1 ↑ (Q1 cycle) to Port Out Valid	—	50	150	ns		
18	TosH2ioI	OSC1 ↑ (Q2 cycle) to Port Input Invalid (I/O in hold time)	PIC18FXX20	100	—	—	ns	
18A			PIC18LFXX20	200	—	—	ns	V _{DD} = 2.0V
19	TioV2osH	Port Input Valid to OSC1 ↑ (I/O in setup time)	0	—	—	ns		
20	TioR	Port Output Rise Time	PIC18FXX20	—	10	25	ns	
20A			PIC18LFXX20	—	—	60	ns	V _{DD} = 2.0V
21	TioF	Port Output Fall Time	PIC18FXX20	—	10	25	ns	
21A			PIC18LFXX20	—	—	60	ns	V _{DD} = 2.0V
22†	TINP	INT pin High or Low Time	T _{CY}	—	—	ns		
23†	TRBP	RB7:RB4 Change INT High or Low Time	T _{CY}	—	—	ns		
24†	TRCP	RC7:RC4 Change INT High or Low Time	20	—	—	ns		

† These parameters are asynchronous events not related to any internal clock edges.

Note 1: Measurements are taken in RC mode, where CLKO output is 4 x T_{OSC}.

FIGURE 26-9: PROGRAM MEMORY READ TIMING DIAGRAM

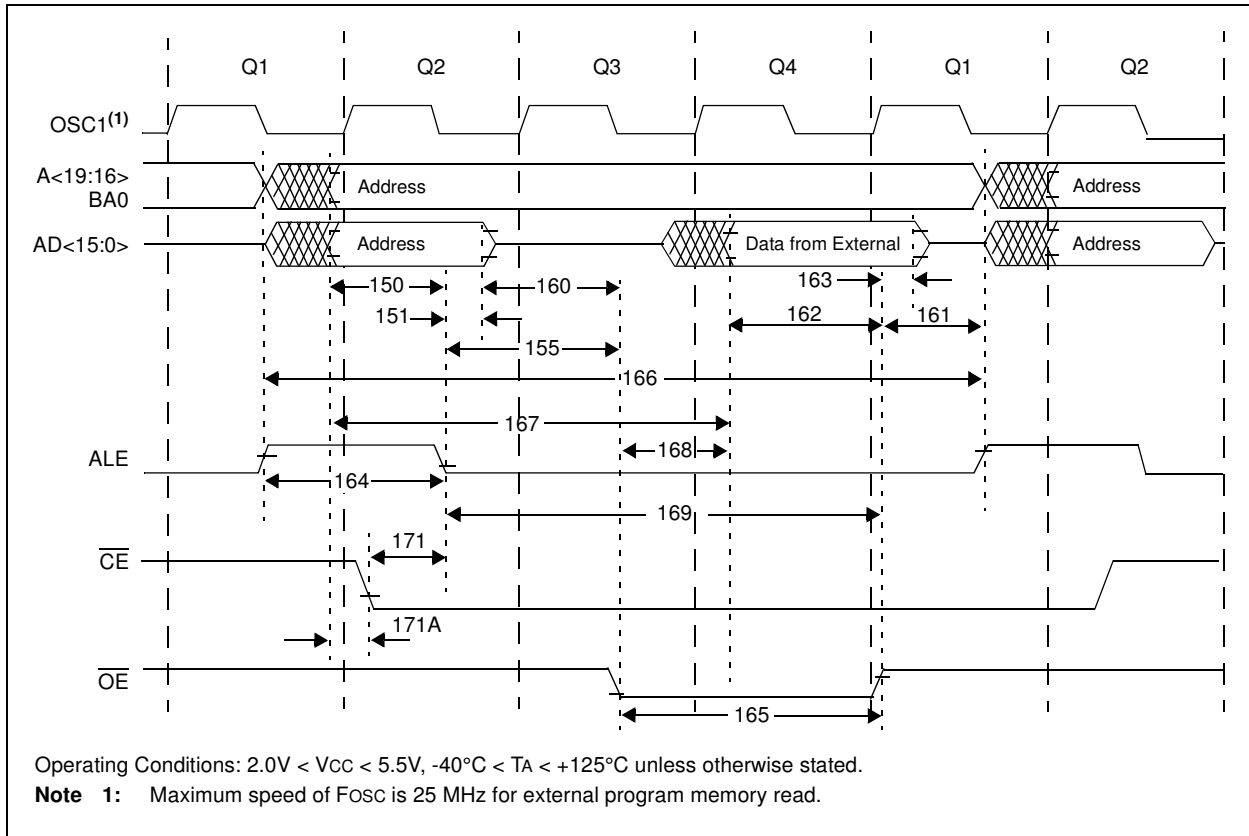

PIC18F6520/8520/6620/8620/6720/8720

TABLE 26-9: CLKO AND I/O TIMING REQUIREMENTS

Param No.	Symbol	Characteristics	Min	Typ	Max	Units
150	TADV2ALL	Address Out Valid to ALE ↓ (address setup time)	$0.25 T_{CY} - 10$	—	—	ns
151	TALL2ADL	ALE ↓ to Address Out Invalid (address hold time)	5	—	—	ns
155	TALL2OEL	ALE ↓ to \overline{OE} ↓	10	$0.125 T_{CY}$	—	ns
160	TADZ2OEL	AD high-Z to \overline{OE} ↓ (bus release to \overline{OE})	0	—	—	ns
161	TOEH2ADD	\overline{OE} ↑ to AD Driven	$0.125 T_{CY} - 5$	—	—	ns
162	TADV2OEH	LS Data Valid before \overline{OE} ↑ (data setup time)	20	—	—	ns
163	TOEH2ADL	\overline{OE} ↑ to Data In Invalid (data hold time)	0	—	—	ns
164	TALH2ALL	ALE Pulse Width	—	$0.25 T_{CY}$	—	ns
165	TOEL2OEH	\overline{OE} Pulse Width	$0.5 T_{CY} - 5$	$0.5 T_{CY}$	—	ns
166	TALH2ALH	ALE ↑ to ALE ↑ (cycle time)	—	T_{CY}	—	ns
167	TACC	Address Valid to Data Valid	$0.75 T_{CY} - 25$	—	—	ns
168	TOE	\overline{OE} ↓ to Data Valid	—	—	$0.5 T_{CY} - 25$	ns
169	TALL2OEH	ALE ↓ to \overline{OE} ↑	$0.625 T_{CY} - 10$	—	$0.625 T_{CY} + 10$	ns
171	TALH2CSL	Chip Enable Active to ALE ↓	—	—	10	ns
171A	TUBL2OEH	AD Valid to Chip Enable Active	$0.25 T_{CY} - 20$	—	—	ns

FIGURE 26-10: PROGRAM MEMORY WRITE TIMING DIAGRAM

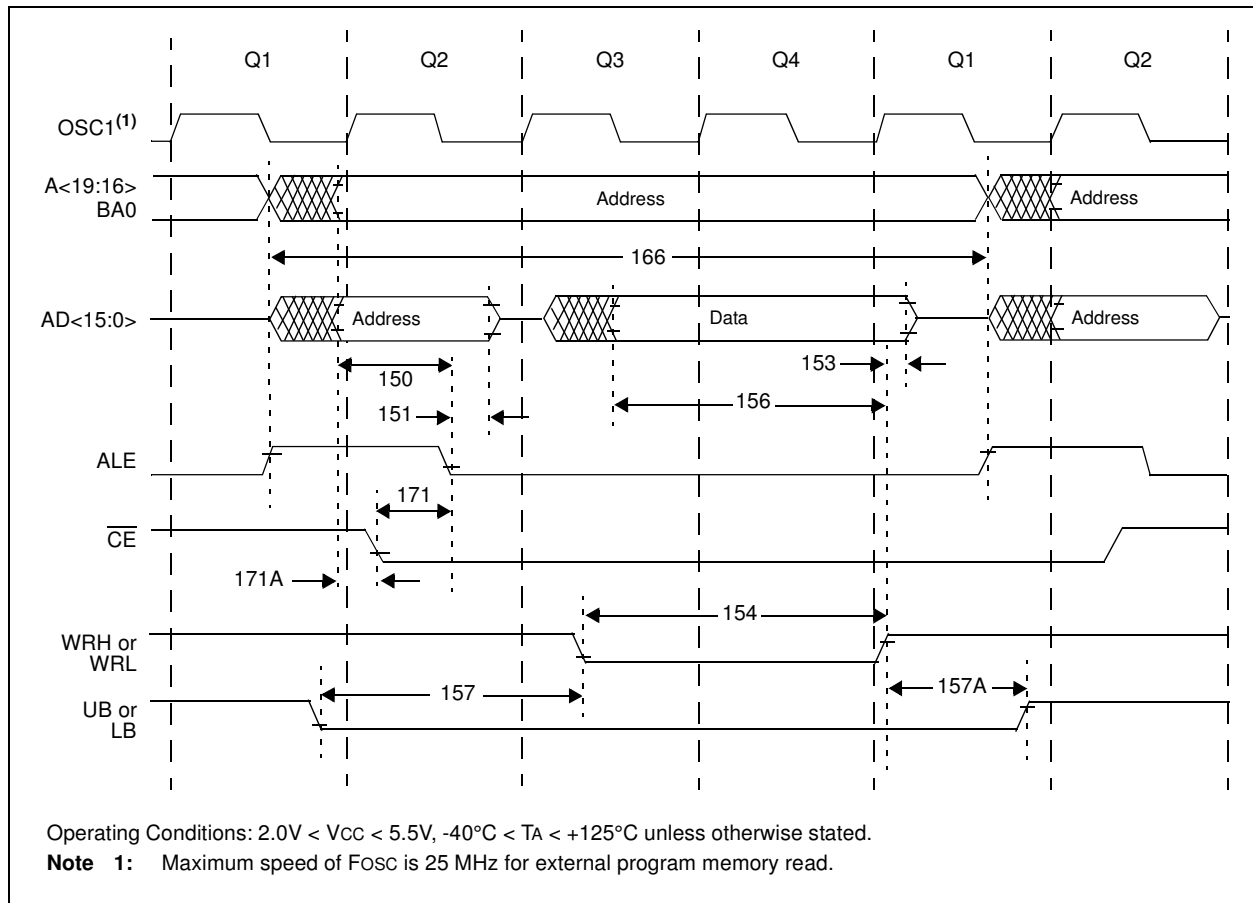

PIC18F6520/8520/6620/8620/6720/8720

TABLE 26-10: PROGRAM MEMORY WRITE TIMING REQUIREMENTS

Param No.	Symbol	Characteristics	Min	Typ	Max	Units
150	TADV2ALL	Address Out Valid to ALE ↓ (address setup time)	$0.25 T_{CY} - 10$	—	—	ns
151	TALL2ADL	ALE ↓ to Address Out Invalid (address hold time)	5	—	—	ns
153	TWRH2ADL	WRn ↑ to Data Out Invalid (data hold time)	5	—	—	ns
154	TWRL	WRn Pulse Width	$0.5 T_{CY} - 5$	$0.5 T_{CY}$	—	ns
156	TADV2WRH	Data Valid before WRn ↑ (data setup time)	$0.5 T_{CY} - 10$	—	—	ns
157	TBSV2WRL	Byte Select Valid before WRn ↓ (byte select setup time)	$0.25 T_{CY}$	—	—	ns
157A	TWRH2BSI	WRn ↑ to Byte Select Invalid (byte select hold time)	$0.125 T_{CY} - 5$	—	—	ns
166	TALH2ALH	ALE ↑ to ALE ↑ (cycle time)	—	T_{CY}	—	ns
171	TALH2CSL	Chip Enable Active to ALE ↓	—	—	10	ns
171A	TUBL2OEH	AD Valid to Chip Enable Active	$0.25 T_{CY} - 20$	—	—	ns

FIGURE 26-11: RESET, WATCHDOG TIMER, OSCILLATOR START-UP TIMER AND POWER-UP TIMER TIMING

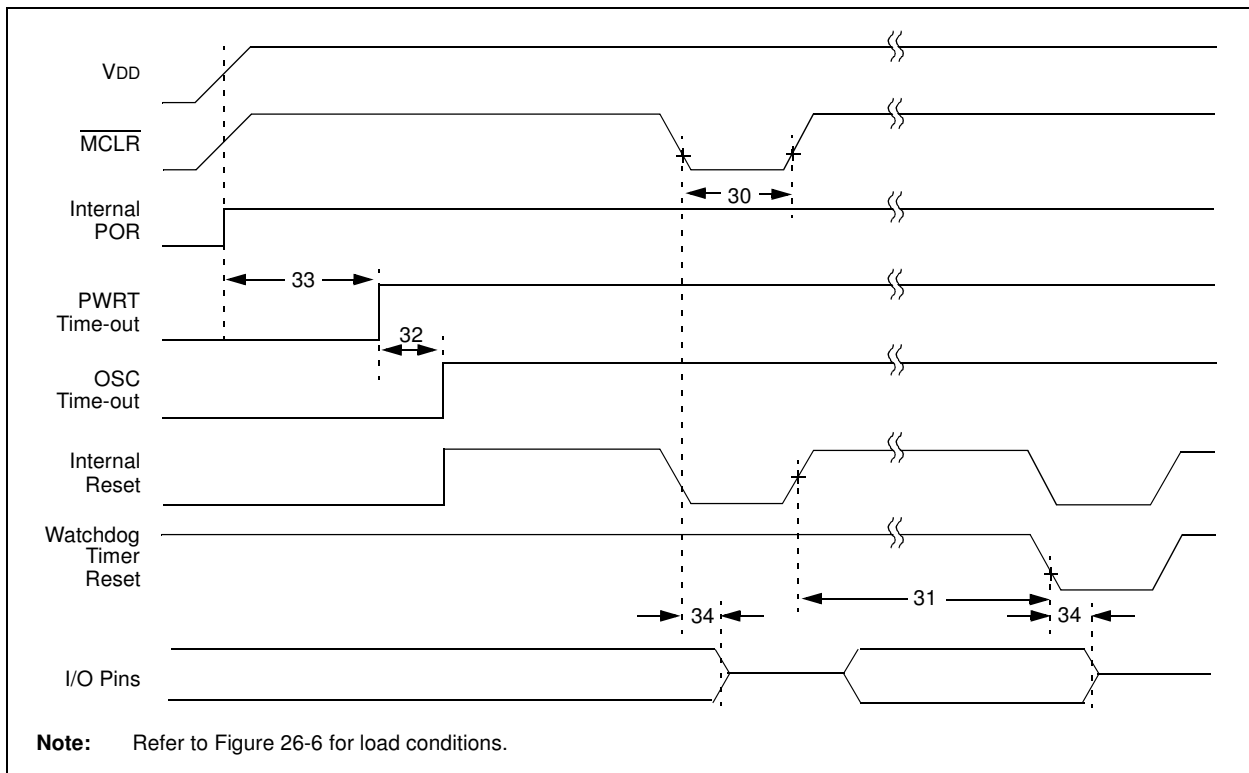

PIC18F6520/8520/6620/8620/6720/8720

FIGURE 26-12: BROWN-OUT RESET TIMING

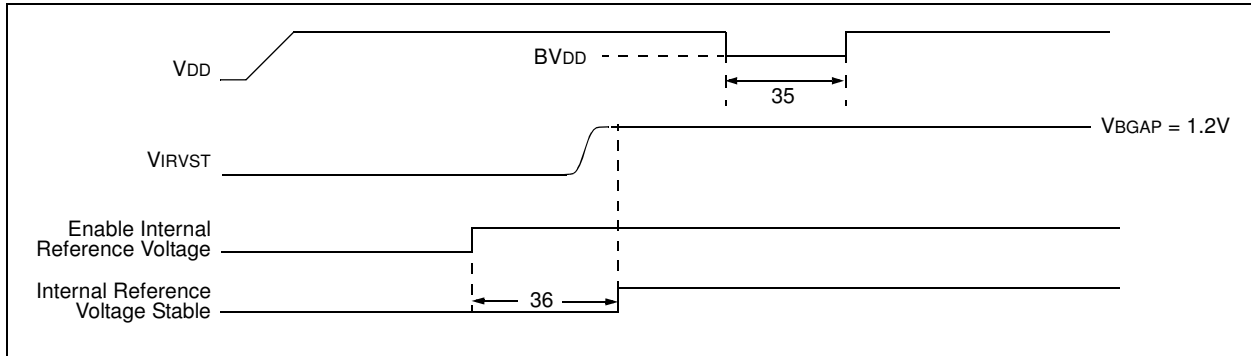
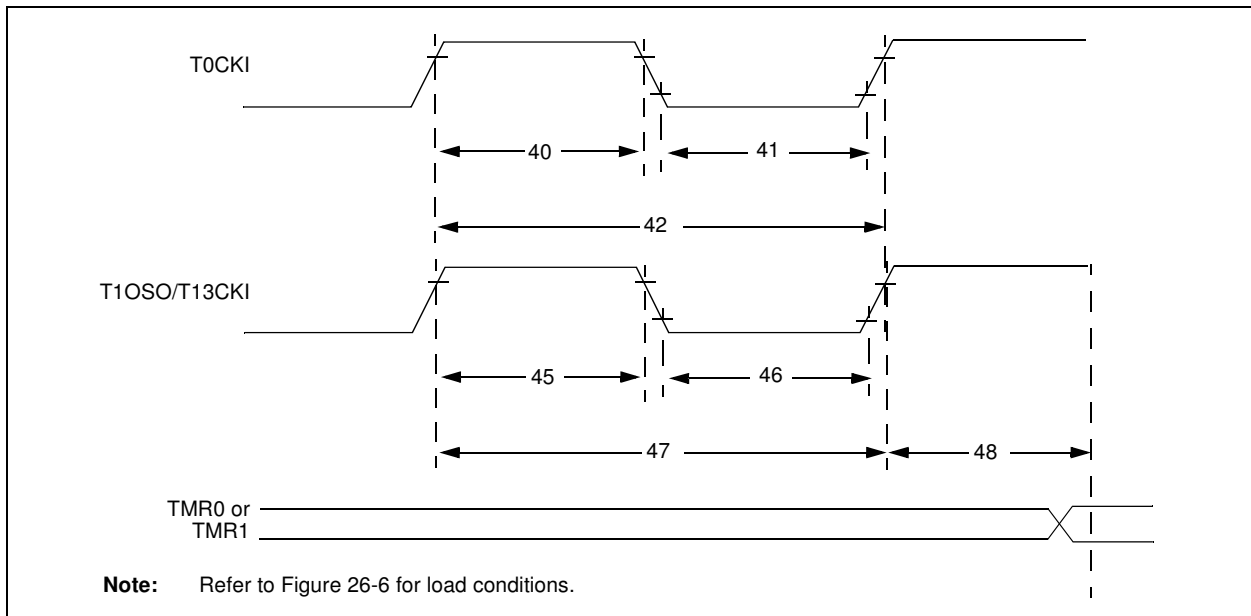

TABLE 26-11: RESET, WATCHDOG TIMER, OSCILLATOR START-UP TIMER, POWER-UP TIMER AND BROWN-OUT RESET REQUIREMENTS

Param No.	Symbol	Characteristic	Min	Typ	Max	Units	Conditions
30	TMCL	$\overline{\text{MCLR}}$ Pulse Width (low)	2	—	—	μs	
31	TWDT	Watchdog Timer Time-out Period (no postscaler)	7	18	33	ms	
32	TOST	Oscillation Start-up Timer Period	1024 TOSC	—	1024 TOSC	—	TOSC = OSC1 period
33	TPWRT	Power-up Timer Period	28	72	132	ms	
34	TIOZ	I/O High-Impedance from $\overline{\text{MCLR}}$ Low or Watchdog Timer Reset	—	2	—	μs	
35	TBOR	Brown-out Reset Pulse Width	200	—	—	μs	$V_{DD} \leq B_{VDD}$ (see D005)
36	TIVRST	Time for Internal Reference Voltage to become stable	—	20	50	μs	
37	TLVD	Low-Voltage Detect Pulse Width	200	—	—	μs	$V_{DD} \leq V_{LVD}$

FIGURE 26-13: TIMER0 AND TIMER1 EXTERNAL CLOCK TIMINGS



PIC18F6520/8520/6620/8620/6720/8720

TABLE 26-12: TIMER0 AND TIMER1 EXTERNAL CLOCK REQUIREMENTS

Param No.	Symbol	Characteristic		Min	Max	Units	Conditions	
40	T _{T0H}	T0CKI High Pulse Width	No prescaler	$0.5 T_{CY} + 20$	—	ns		
			With prescaler	10	—	ns		
41	T _{T0L}	T0CKI Low Pulse Width	No prescaler	$0.5 T_{CY} + 20$	—	ns		
			With prescaler	10	—	ns		
42	T _{T0P}	T0CKI Period	No prescaler	$T_{CY} + 10$	—	ns	N = prescale value (1, 2, 4, ..., 256)	
			With prescaler	Greater of: $20 \text{ ns or } \frac{T_{CY} + 40}{N}$	—	ns		
45	T _{T1H}	T13CKI High Time	Synchronous, no prescaler	$0.5 T_{CY} + 20$	—	ns		
			Synchronous, with prescaler	PIC18FXX20	10	—		ns
				PIC18LFXX20	25	—		ns
			Asynchronous	PIC18FXX20	30	—		ns
PIC18LFXX20	50	—		ns				
46	T _{T1L}	T13CKI Low Time	Synchronous, no prescaler	$0.5 T_{CY} + 5$	—	ns		
			Synchronous, with prescaler	PIC18FXX20	10	—		ns
				PIC18LFXX20	25	—		ns
			Asynchronous	PIC18FXX20	30	—		ns
PIC18LFXX20	TBD	TBD		ns				
47	T _{T1P}	T13CKI Input Period	Synchronous	Greater of: $20 \text{ ns or } \frac{T_{CY} + 40}{N}$	—	ns	N = prescale value (1, 2, 4, 8)	
			Asynchronous	60	—	ns		
	F _{T1}	T13CKI Oscillator Input Frequency Range		DC	50	kHz		
48	T _{CKE2TMR1}	Delay from External T13CKI Clock Edge to Timer Increment		$2 T_{osc}$	$7 T_{osc}$	—		

FIGURE 26-14: CAPTURE/COMPARE/PWM TIMINGS (ALL CCP MODULES)

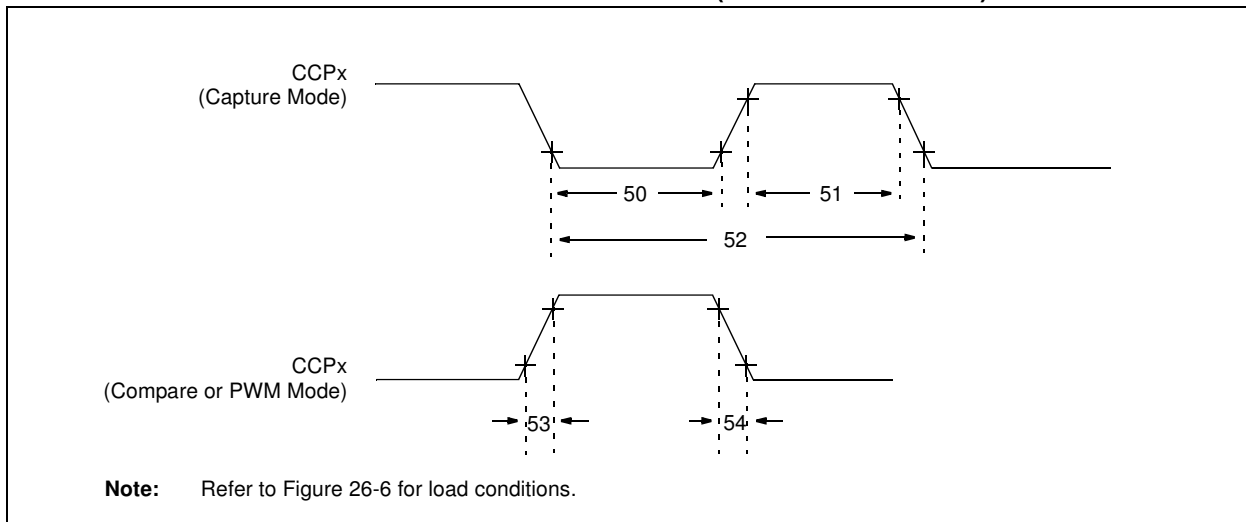

PIC18F6520/8520/6620/8620/6720/8720

TABLE 26-13: CAPTURE/COMPARE/PWM REQUIREMENTS (ALL CCP MODULES)

Param No.	Symbol	Characteristic		Min	Max	Units	Conditions	
50	TccL	CCPx Input Low Time	No prescaler	$0.5 T_{CY} + 20$	—	ns		
			With prescaler	PIC18FXX20	10	—		ns
				PIC18LFXX20	20	—		ns
51	TccH	CCPx Input High Time	No prescaler	$0.5 T_{CY} + 20$	—	ns		
			With prescaler	PIC18FXX20	10	—		ns
				PIC18LFXX20	20	—		ns
52	TccP	CCPx Input Period		$\frac{3 T_{CY} + 40}{N}$	—	ns	N = prescale value (1, 4 or 16)	
53	TccR	CCPx Output Rise Time	PIC18FXX20	—	25	ns	V _{DD} = 2.0V	
			PIC18LFXX20	—	45	ns		
54	TccF	CCPx Output Fall Time	PIC18FXX20	—	25	ns	V _{DD} = 2.0V	
			PIC18LFXX20	—	45	ns		

FIGURE 26-15: PARALLEL SLAVE PORT TIMING (PIC18F8X20)

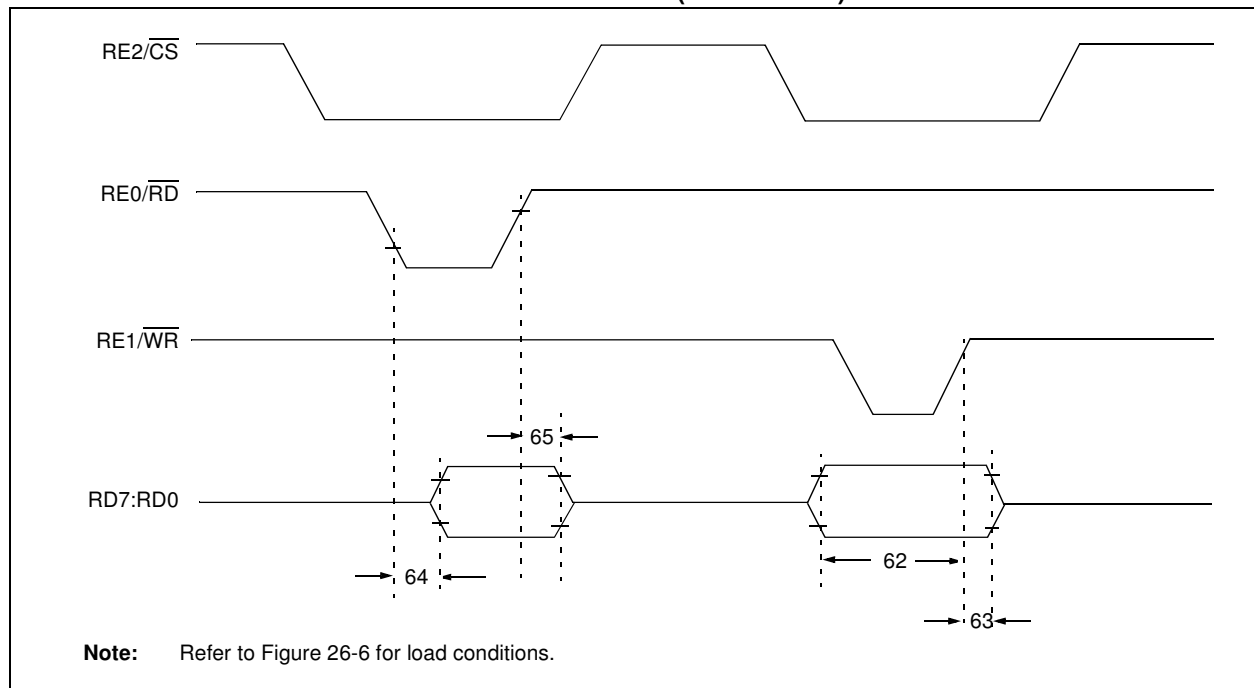

PIC18F6520/8520/6620/8620/6720/8720

TABLE 26-14: PARALLEL SLAVE PORT REQUIREMENTS (PIC18F8X20)

Param No.	Symbol	Characteristic	Min	Max	Units	Conditions	
62	TDTV2WRH	Data In Valid before $\overline{WR} \uparrow$ or $\overline{CS} \uparrow$ (setup time)	20 25	—	ns ns	Extended Temp. range	
63	TWRH2DTI	$\overline{WR} \uparrow$ or $\overline{CS} \uparrow$ to Data-In Invalid (hold time)	PIC18FXX20	20	—	ns	VDD = 2.0V
			PIC18LFXX20	35	—	ns	
64	TRDL2DTV	$\overline{RD} \downarrow$ and $\overline{CS} \downarrow$ to Data-Out Valid	—	80	ns	Extended Temp. range	
			—	90	ns		
65	TRDH2DTI	$\overline{RD} \uparrow$ or $\overline{CS} \downarrow$ to Data-Out Invalid	10	30	ns		
66	TIBFINH	Inhibit of the IBF flag bit being cleared from $\overline{WR} \uparrow$ or $\overline{CS} \uparrow$	—	3 Tcy			

FIGURE 26-16: EXAMPLE SPI MASTER MODE TIMING (CKE = 0)

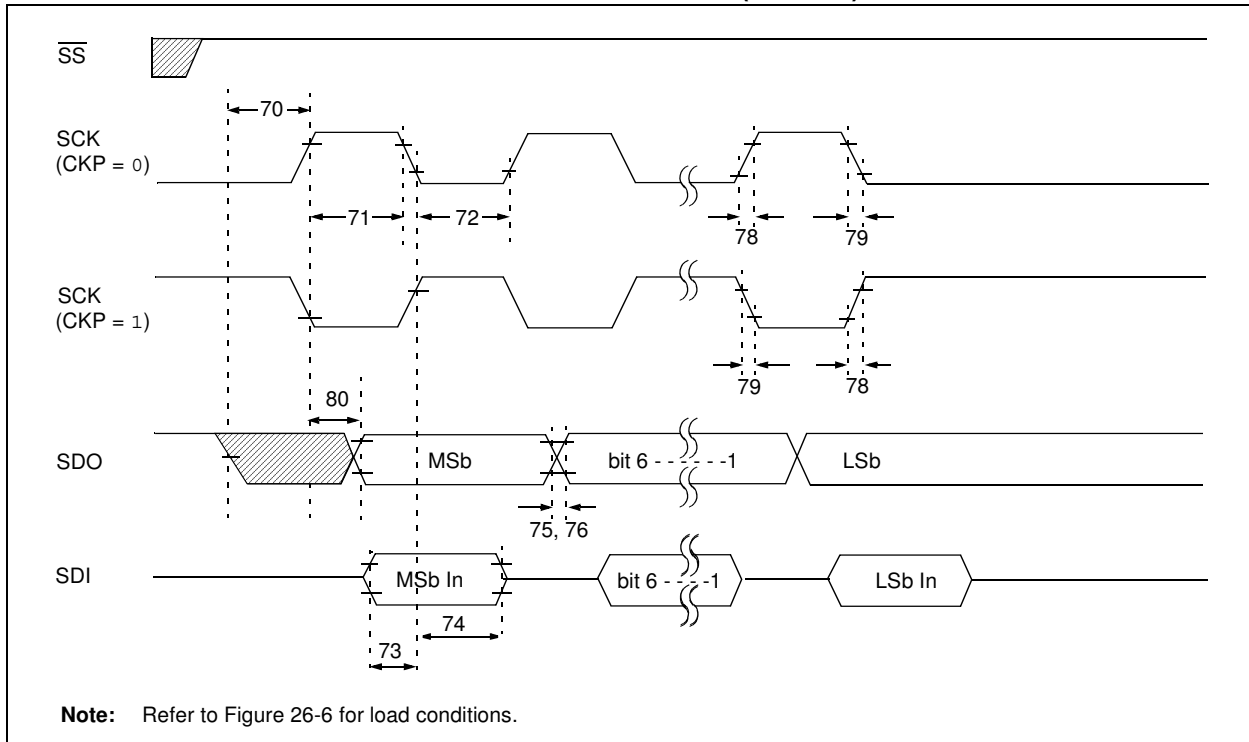

PIC18F6520/8520/6620/8620/6720/8720

TABLE 26-15: EXAMPLE SPI MODE REQUIREMENTS (MASTER MODE, CKE = 0)

Param No.	Symbol	Characteristic	Min	Max	Units	Conditions
70	TssL2sclH, TssL2sclL	\overline{SS} ↓ to SCK ↓ or SCK ↑ Input	T _{CY}	—	ns	
71	Tsch	SCK Input High Time (Slave mode)	Continuous	1.25 T _{CY} + 30	—	ns
71A			Single Byte	40	—	ns
72	TscL	SCK Input Low Time (Slave mode)	Continuous	1.25 T _{CY} + 30	—	ns
72A			Single Byte	40	—	ns
73	TdIV2sclH, TdIV2sclL	Setup Time of SDI Data Input to SCK Edge	100	—	ns	
73A	TB2B	Last Clock Edge of Byte 1 to the 1st Clock Edge of Byte 2	1.5 T _{CY} + 40	—	ns	(Note 2)
74	Tsch2diL, TscL2diL	Hold Time of SDI Data Input to SCK Edge	100	—	ns	
75	TdoR	SDO Data Output Rise Time	PIC18FXX20	—	25	ns
			PIC18LFXX20	—	45	ns
76	TdoF	SDO Data Output Fall Time	—	25	ns	
78	TscR	SCK Output Rise Time (Master mode)	PIC18FXX20	—	25	ns
			PIC18LFXX20	—	45	ns
79	TscF	SCK Output Fall Time (Master mode)	—	25	ns	
80	Tsch2doV, TscL2doV	SDO Data Output Valid after SCK Edge	PIC18FXX20	—	50	ns
			PIC18LFXX20	—	100	ns

- Note 1:** Requires the use of Parameter #73A.
Note 2: Only if Parameter #71A and #72A are used.

FIGURE 26-17: EXAMPLE SPI MASTER MODE TIMING (CKE = 1)

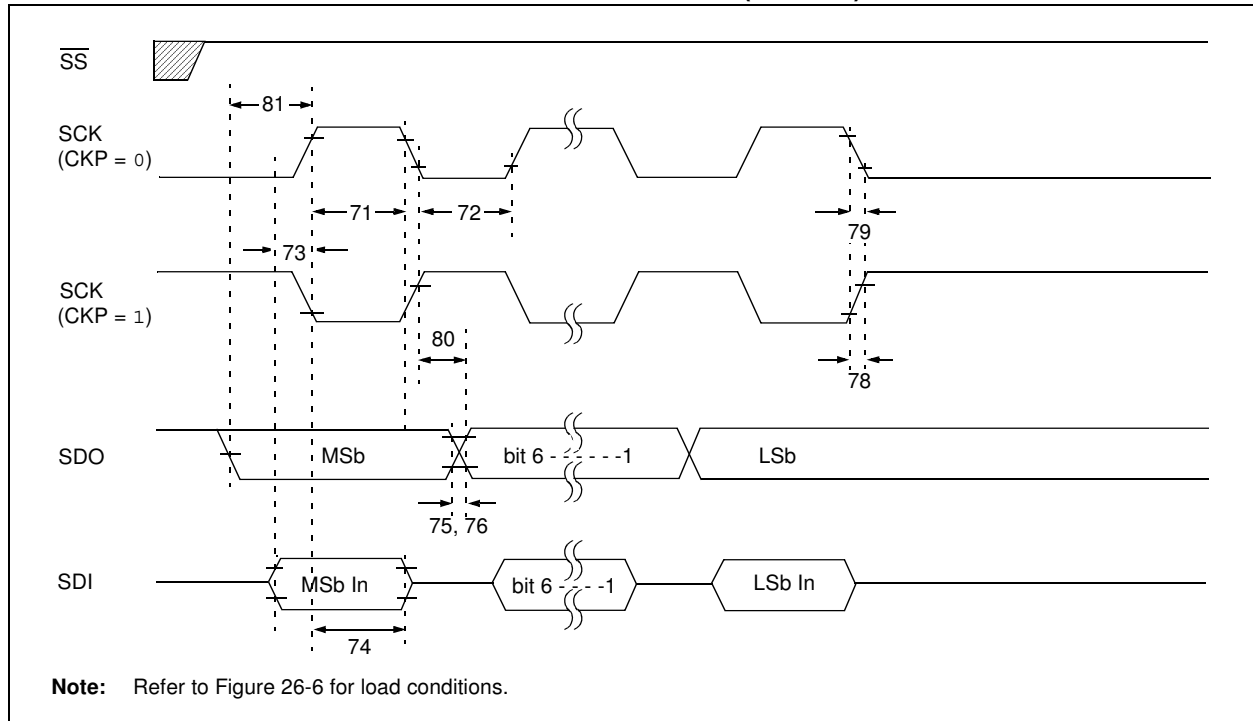

PIC18F6520/8520/6620/8620/6720/8720

TABLE 26-16: EXAMPLE SPI MODE REQUIREMENTS (MASTER MODE, CKE = 1)

Param No.	Symbol	Characteristic	Min	Max	Units	Conditions
71	Tsch	SCK Input High Time	Continuous	1.25 T _{CY} + 30	ns	
71A		(Slave mode)	Single Byte	40	ns	(Note 1)
72	Tscl	SCK Input Low Time	Continuous	1.25 T _{CY} + 30	ns	
72A		(Slave mode)	Single Byte	40	ns	(Note 1)
73	TdIV2sch, TdIV2scl	Setup Time of SDI Data Input to SCK Edge	100	—	ns	
73A	Tb2B	Last Clock Edge of Byte 1 to the 1st Clock Edge of Byte 2	1.5 T _{CY} + 40	—	ns	(Note 2)
74	Tsch2dIL, Tscl2dIL	Hold Time of SDI Data Input to SCK Edge	100	—	ns	
75	TdOR	SDO Data Output Rise Time	PIC18FXX20 PIC18LFXX20	— 45	ns	V _{DD} = 2.0V
76	TdOF	SDO Data Output Fall Time	—	25	ns	
78	Tscr	SCK Output Rise Time	PIC18FXX20 PIC18LFXX20	— 45	ns	V _{DD} = 2.0V
79	Tscf	SCK Output Fall Time (Master mode)	—	25	ns	
80	Tsch2dOV, Tscl2dOV	SDO Data Output Valid after SCK Edge	PIC18FXX20 PIC18LFXX20	— 100	ns	V _{DD} = 2.0V
81	TdOV2sch, TdOV2scl	SDO Data Output Setup to SCK Edge	T _{CY}	—	ns	

- Note 1:** Requires the use of Parameter #73A.
Note 2: Only if Parameter #71A and #72A are used.

FIGURE 26-18: EXAMPLE SPI SLAVE MODE TIMING (CKE = 0)

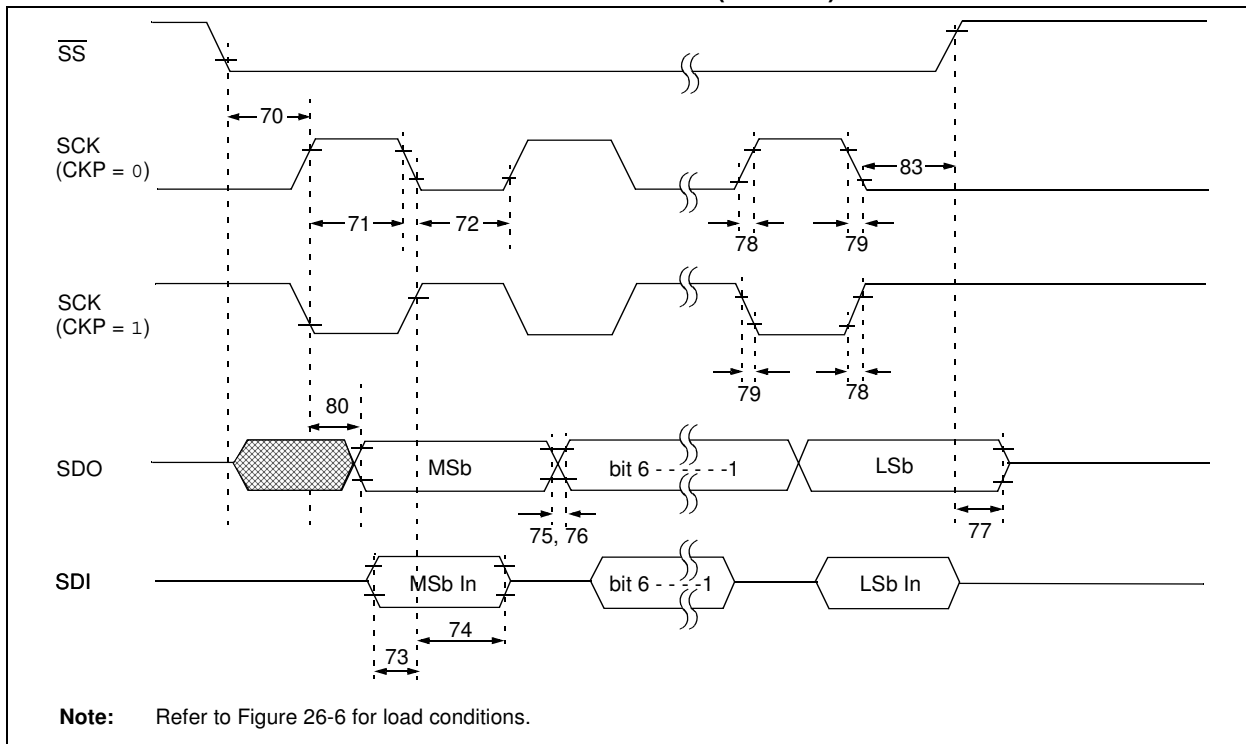

PIC18F6520/8520/6620/8620/6720/8720

TABLE 26-17: EXAMPLE SPI MODE REQUIREMENTS (SLAVE MODE TIMING, CKE = 0)

Param No.	Symbol	Characteristic	Min	Max	Units	Conditions
70	TssL2sch, TssL2scl	\overline{SS} ↓ to SCK ↓ or SCK ↑ Input	T _{CY}	—	ns	
71	Tsch	SCK Input High Time (Slave mode)	Continuous	1.25 T _{CY} + 30	—	ns
71A			Single Byte	40	—	ns
72	TscL	SCK Input Low Time (Slave mode)	Continuous	1.25 T _{CY} + 30	—	ns
72A			Single Byte	40	—	ns
73	TdIV2sch, TdIV2scl	Setup Time of SDI Data Input to SCK Edge	100	—	ns	
73A	Tb2B	Last Clock Edge of Byte 1 to the First Clock Edge of Byte 2	1.5 T _{CY} + 40	—	ns	(Note 2)
74	Tsch2dIL, TscL2dIL	Hold Time of SDI Data Input to SCK Edge	100	—	ns	
75	TdoR	SDO Data Output Rise Time	PIC18FXX20	—	25	ns
			PIC18LFXX20	—	45	ns
76	TdoF	SDO Data Output Fall Time	—	25	ns	
77	TssH2doZ	\overline{SS} ↑ to SDO Output High-Impedance	10	50	ns	
78	Tscr	SCK Output Rise Time (Master mode)	PIC18FXX20	—	25	ns
			PIC18LFXX20	—	45	ns
79	TscF	SCK Output Fall Time (Master mode)	—	25	ns	
80	Tsch2doV, TscL2doV	SDO Data Output Valid after SCK Edge	PIC18FXX20	—	50	ns
			PIC18LFXX20	—	100	ns
83	Tsch2ssh, TscL2ssh	\overline{SS} ↑ after SCK Edge	1.5 T _{CY} + 40	—	ns	

Note 1: Requires the use of Parameter #73A.

Note 2: Only if Parameter #71A and #72A are used.

FIGURE 26-19: EXAMPLE SPI SLAVE MODE TIMING (CKE = 1)

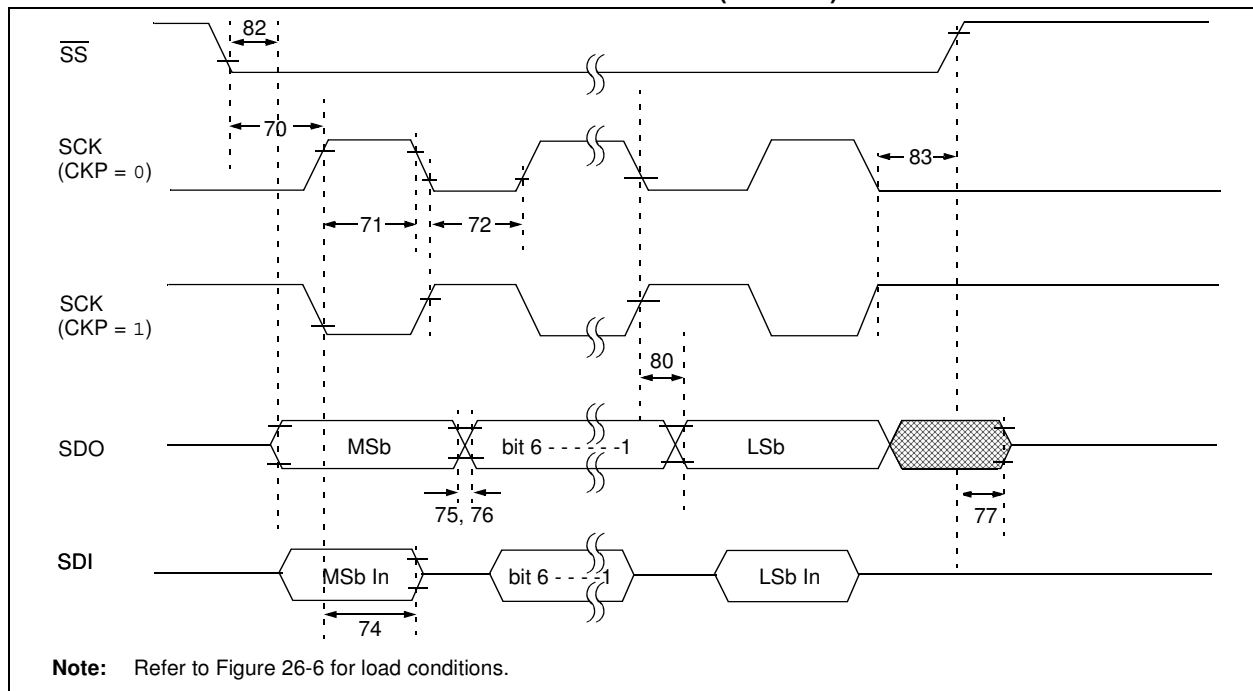

PIC18F6520/8520/6620/8620/6720/8720

TABLE 26-18: EXAMPLE SPI SLAVE MODE REQUIREMENTS (CKE = 1)

Param No.	Symbol	Characteristic	Min	Max	Units	Conditions
70	TssL2sch, TssL2scl	\overline{SS} ↓ to SCK ↓ or SCK ↑ Input	T _{CY}	—	ns	
71	Tsch	SCK Input High Time (Slave mode)	Continuous	1.25 T _{CY} + 30	—	ns
71A			Single Byte	40	—	ns
72	TscL	SCK Input Low Time (Slave mode)	Continuous	1.25 T _{CY} + 30	—	ns
72A			Single Byte	40	—	ns
73A	Tb2B	Last Clock Edge of Byte 1 to the First Clock Edge of Byte 2	1.5 T _{CY} + 40	—	ns	(Note 2)
74	Tsch2dIL, TscL2dIL	Hold Time of SDI Data Input to SCK Edge	100	—	ns	
75	TdoR	SDO Data Output Rise Time	PIC18FXX20	—	25	ns
			PIC18LFXX20	—	45	ns
76	TdoF	SDO Data Output Fall Time	—	25	ns	
77	TssH2doZ	\overline{SS} ↑ to SDO Output High-Impedance	10	50	ns	
78	Tscr	SCK Output Rise Time (Master mode)	PIC18FXX20	—	25	ns
			PIC18LFXX20	—	45	ns
79	TscF	SCK Output Fall Time (Master mode)	—	25	ns	
80	Tsch2doV, TscL2doV	SDO Data Output Valid after SCK Edge	PIC18FXX20	—	50	ns
			PIC18LFXX20	—	100	ns
82	TssL2doV	SDO Data Output Valid after \overline{SS} ↓ Edge	PIC18FXX20	—	50	ns
			PIC18LFXX20	—	100	ns
83	Tsch2ssH, TscL2ssH	\overline{SS} ↑ after SCK Edge	1.5 T _{CY} + 40	—	ns	

Note 1: Requires the use of Parameter #73A.

Note 2: Only if Parameter #71A and #72A are used.

FIGURE 26-20: I²C BUS START/STOP BITS TIMING

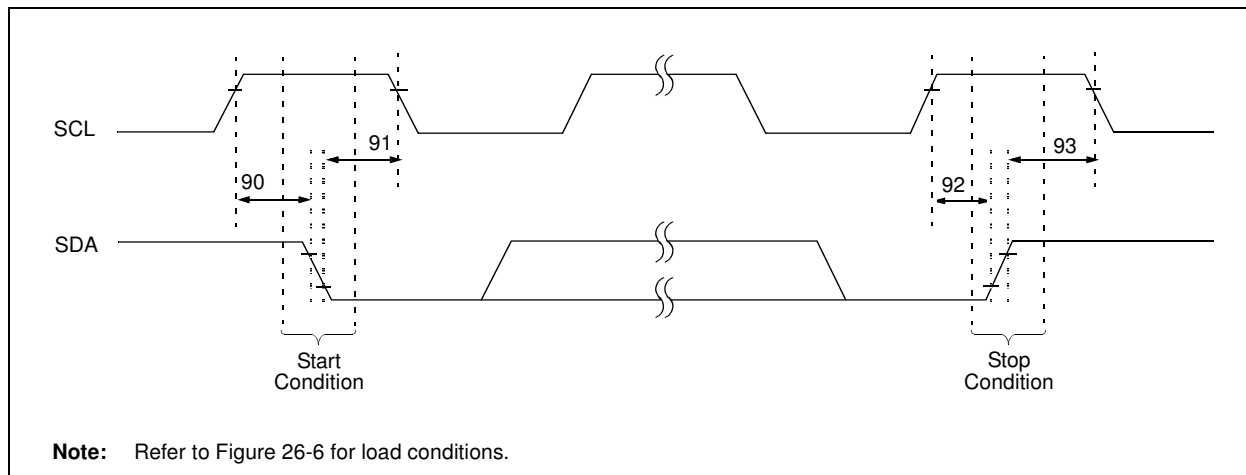

PIC18F6520/8520/6620/8620/6720/8720

TABLE 26-19: I²C BUS START/STOP BITS REQUIREMENTS (SLAVE MODE)

Param No.	Symbol	Characteristic	Min	Max	Units	Conditions	
90	TSU:STA	Start Condition Setup Time	100 kHz mode	4700	—	ns	Only relevant for Repeated Start condition
			400 kHz mode	600	—		
91	THD:STA	Start Condition Hold Time	100 kHz mode	4000	—	ns	After this period, the first clock pulse is generated
			400 kHz mode	600	—		
92	TSU:STO	Stop Condition Setup Time	100 kHz mode	4700	—	ns	
			400 kHz mode	600	—		
93	THD:STO	Stop Condition Hold Time	100 kHz mode	4000	—	ns	
			400 kHz mode	600	—		

FIGURE 26-21: I²C BUS DATA TIMING

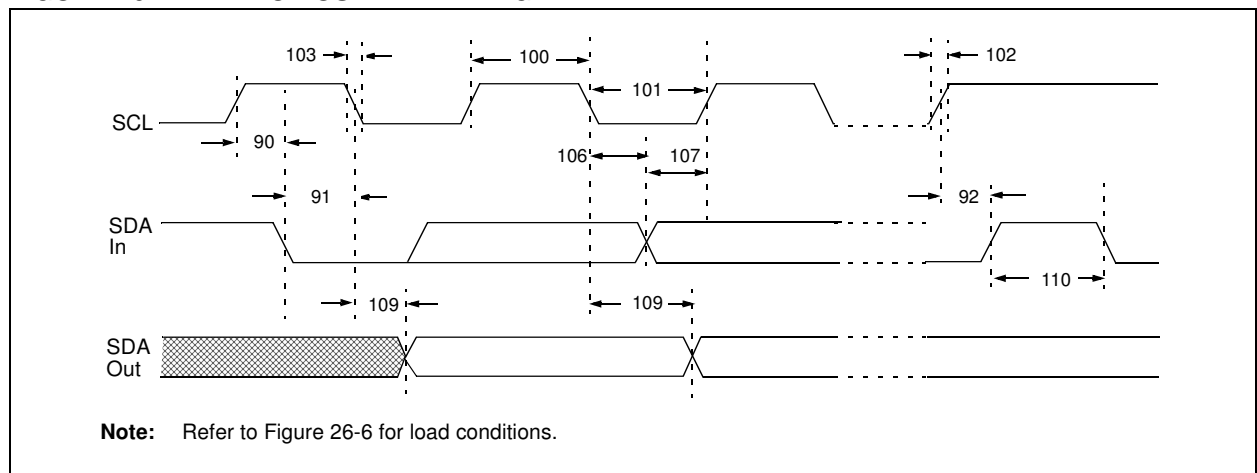

PIC18F6520/8520/6620/8620/6720/8720

TABLE 26-20: I²C BUS DATA REQUIREMENTS (SLAVE MODE)

Param No.	Symbol	Characteristic	Min	Max	Units	Conditions	
100	THIGH	Clock High Time	100 kHz mode	4.0	—	μs	
			400 kHz mode	0.6	—	μs	
			SSP module	1.5 T _{CY}	—		
101	TLOW	Clock Low Time	100 kHz mode	4.7	—	μs	PIC18FXX20 must operate at a minimum of 1.5 MHz
			400 kHz mode	1.3	—	μs	PIC18FXX20 must operate at a minimum of 10 MHz
			SSP module	1.5 T _{CY}	—		
102	TR	SDA and SCL Rise Time	100 kHz mode	—	1000	ns	
			400 kHz mode	20 + 0.1 C _B	300	ns	C _B is specified to be from 10 to 400 pF
103	TF	SDA and SCL Fall Time	100 kHz mode	—	300	ns	
			400 kHz mode	20 + 0.1 C _B	300	ns	C _B is specified to be from 10 to 400 pF
90	TSU:STA	Start Condition Setup Time	100 kHz mode	4.7	—	μs	Only relevant for Repeated Start condition
			400 kHz mode	0.6	—	μs	
91	THD:STA	Start Condition Hold Time	100 kHz mode	4.0	—	μs	After this period, the first clock pulse is generated
			400 kHz mode	0.6	—	μs	
106	THD:DAT	Data Input Hold Time	100 kHz mode	0	—	ns	
			400 kHz mode	0	0.9	μs	
107	TSU:DAT	Data Input Setup Time	100 kHz mode	250	—	ns	(Note 2)
			400 kHz mode	100	—	ns	
92	TSU:STO	Stop Condition Setup Time	100 kHz mode	4.7	—	μs	
			400 kHz mode	0.6	—	μs	
109	TAA	Output Valid from Clock	100 kHz mode	—	3500	ns	(Note 1)
			400 kHz mode	—	—	ns	
110	TBUF	Bus Free Time	100 kHz mode	4.7	—	μs	Time the bus must be free before a new transmission can start
			400 kHz mode	1.3	—	μs	
D102	C _B	Bus Capacitive Loading	—	400	pF		

Note 1: As a transmitter, the device must provide this internal minimum delay time to bridge the undefined region (min. 300 ns) of the falling edge of SCL to avoid unintended generation of Start or Stop conditions.

2: A fast mode I²C bus device can be used in a standard mode I²C bus system but the requirement, TSU:DAT ≥ 250 ns, must then be met. This will automatically be the case if the device does not stretch the LOW period of the SCL signal. If such a device does stretch the LOW period of the SCL signal, it must output the next data bit to the SDA line, TR max. + TSU:DAT = 1000 + 250 = 1250 ns (according to the standard mode I²C bus specification), before the SCL line is released.

PIC18F6520/8520/6620/8620/6720/8720

FIGURE 26-22: MASTER SSP I²C BUS START/STOP BITS TIMING WAVEFORMS

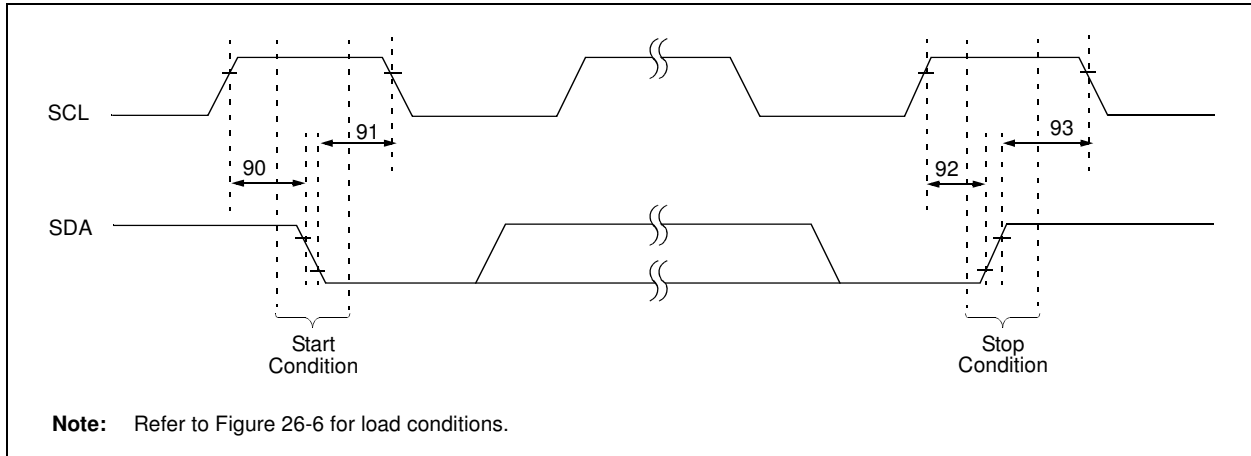
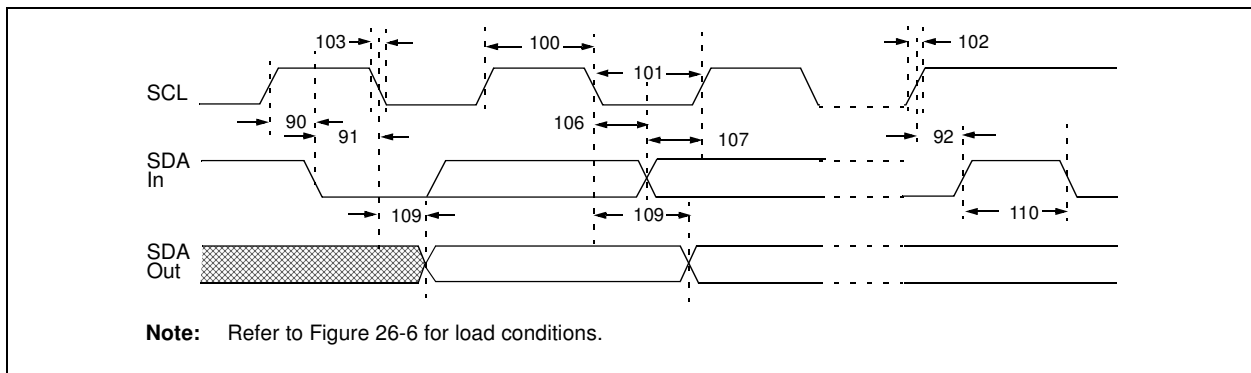

TABLE 26-21: MASTER SSP I²C BUS START/STOP BITS REQUIREMENTS

Param No.	Symbol	Characteristic	Min	Max	Units	Conditions	
90	TSU:STA	Start Condition Setup Time	100 kHz mode	$2(T_{osc})(BRG + 1)$	—	ns	Only relevant for Repeated Start condition
			400 kHz mode	$2(T_{osc})(BRG + 1)$	—		
			1 MHz mode ⁽¹⁾	$2(T_{osc})(BRG + 1)$	—		
91	THD:STA	Start Condition Hold Time	100 kHz mode	$2(T_{osc})(BRG + 1)$	—	ns	After this period, the first clock pulse is generated
			400 kHz mode	$2(T_{osc})(BRG + 1)$	—		
			1 MHz mode ⁽¹⁾	$2(T_{osc})(BRG + 1)$	—		
92	TSU:STO	Stop Condition Setup Time	100 kHz mode	$2(T_{osc})(BRG + 1)$	—	ns	
			400 kHz mode	$2(T_{osc})(BRG + 1)$	—		
			1 MHz mode ⁽¹⁾	$2(T_{osc})(BRG + 1)$	—		
93	THD:STO	Stop Condition Hold Time	100 kHz mode	$2(T_{osc})(BRG + 1)$	—	ns	
			400 kHz mode	$2(T_{osc})(BRG + 1)$	—		
			1 MHz mode ⁽¹⁾	$2(T_{osc})(BRG + 1)$	—		

Note 1: Maximum pin capacitance = 10 pF for all I²C pins.

FIGURE 26-23: MASTER SSP I²C BUS DATA TIMING



PIC18F6520/8520/6620/8620/6720/8720

TABLE 26-22: MASTER SSP I²C BUS DATA REQUIREMENTS

Param No.	Symbol	Characteristic	Min	Max	Units	Conditions
100	THIGH	Clock High Time	100 kHz mode	2(Tosc)(BRG + 1)	—	ms
			400 kHz mode	2(Tosc)(BRG + 1)	—	ms
			1 MHz mode ⁽¹⁾	2(Tosc)(BRG + 1)	—	ms
101	TLOW	Clock Low Time	100 kHz mode	2(Tosc)(BRG + 1)	—	ms
			400 kHz mode	2(Tosc)(BRG + 1)	—	ms
			1 MHz mode ⁽¹⁾	2(Tosc)(BRG + 1)	—	ms
102	TR	SDA and SCL Rise Time	100 kHz mode	—	1000	ns
			400 kHz mode	20 + 0.1 Cb	300	ns
			1 MHz mode ⁽¹⁾	—	300	ns
103	TF	SDA and SCL Fall Time	100 kHz mode	—	300	ns
			400 kHz mode	20 + 0.1 Cb	300	ns
			1 MHz mode ⁽¹⁾	—	100	ns
90	TSU:STA	Start Condition Setup Time	100 kHz mode	2(Tosc)(BRG + 1)	—	ms
			400 kHz mode	2(Tosc)(BRG + 1)	—	ms
			1 MHz mode ⁽¹⁾	2(Tosc)(BRG + 1)	—	ms
91	THD:STA	Start Condition Hold Time	100 kHz mode	2(Tosc)(BRG + 1)	—	ms
			400 kHz mode	2(Tosc)(BRG + 1)	—	ms
			1 MHz mode ⁽¹⁾	2(Tosc)(BRG + 1)	—	ms
106	THD:DAT	Data Input Hold Time	100 kHz mode	0	—	ns
			400 kHz mode	0	0.9	ms
			1 MHz mode ⁽¹⁾	TBD	—	ns
107	TSU:DAT	Data Input Setup Time	100 kHz mode	250	—	ns
			400 kHz mode	100	—	ns
			1 MHz mode ⁽¹⁾	TBD	—	ns
92	TSU:STO	Stop Condition Setup Time	100 kHz mode	2(Tosc)(BRG + 1)	—	ms
			400 kHz mode	2(Tosc)(BRG + 1)	—	ms
			1 MHz mode ⁽¹⁾	2(Tosc)(BRG + 1)	—	ms
109	TAA	Output Valid from Clock	100 kHz mode	—	3500	ns
			400 kHz mode	—	1000	ns
			1 MHz mode ⁽¹⁾	—	—	ns
110	TBUF	Bus Free Time	100 kHz mode	4.7	—	ms
			400 kHz mode	1.3	—	ms
			1 MHz mode ⁽¹⁾	TBD	—	ms
D102	Cb	Bus Capacitive Loading	—	400	pF	

Note 1: Maximum pin capacitance = 10 pF for all I²C pins.

2: A fast mode I²C bus device can be used in a standard mode I²C bus system, but parameter #107 ≥ 250 ns, must then be met. This will automatically be the case if the device does not stretch the LOW period of the SCL signal. If such a device does stretch the LOW period of the SCL signal, it must output the next data bit to the SDA line, parameter #102 + parameter #107 = 1000 + 250 = 1250 ns (for 100 kHz mode), before the SCL line is released.

PIC18F6520/8520/6620/8620/6720/8720

FIGURE 26-24: USART SYNCHRONOUS TRANSMISSION (MASTER/SLAVE) TIMING

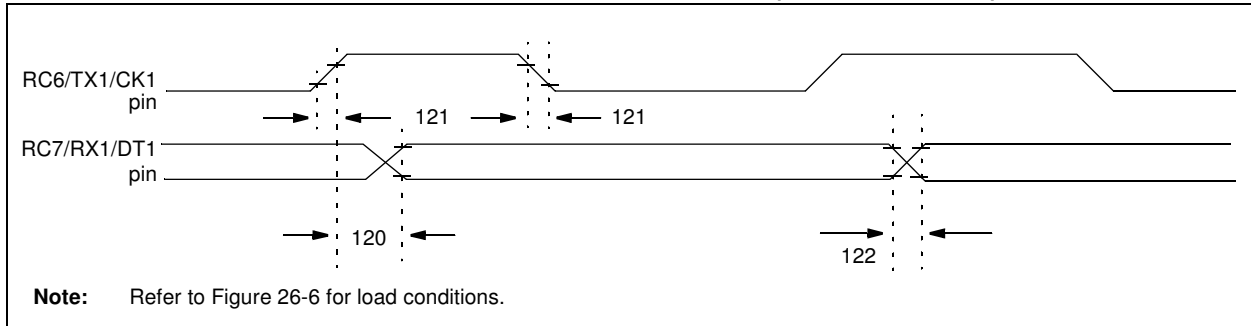

TABLE 26-23: USART SYNCHRONOUS TRANSMISSION REQUIREMENTS

Param No.	Symbol	Characteristic	Min	Max	Units	Conditions
120	T _{CKH2DTV}	SYNC XMIT (MASTER & SLAVE) Clock High to Data Out Valid	PIC18FXX20	—	40	ns
			PIC18LFXX20	—	100	ns
121	T _{CKRF}	Clock Out Rise Time and Fall Time (Master mode)	PIC18FXX20	—	20	ns
			PIC18LFXX20	—	50	ns
122	T _{DTRF}	Data Out Rise Time and Fall Time	PIC18FXX20	—	20	ns
			PIC18LFXX20	—	50	ns

FIGURE 26-25: USART SYNCHRONOUS RECEIVE (MASTER/SLAVE) TIMING

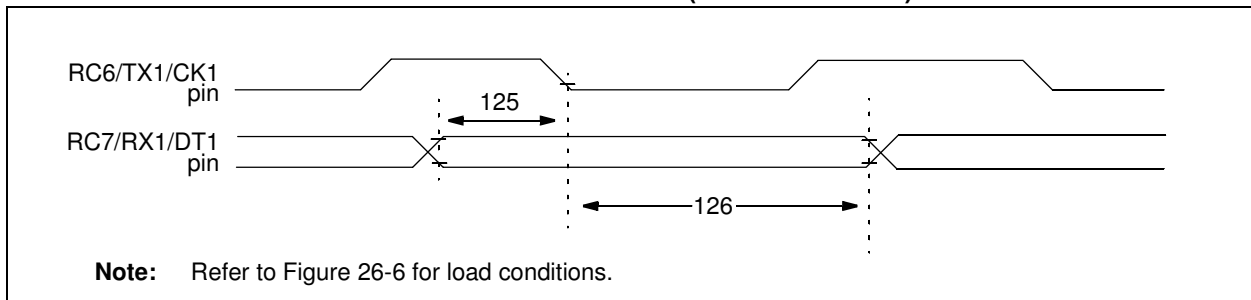

TABLE 26-24: USART SYNCHRONOUS RECEIVE REQUIREMENTS

Param No.	Symbol	Characteristic	Min	Max	Units	Conditions
125	T _{DtV2CKL}	SYNC RCV (MASTER & SLAVE) Data Hold before CK ↓ (DT hold time)	10	—	ns	
126	T _{CKL2DTL}	Data Hold after CK ↓ (DT hold time)	15	—	ns	

PIC18F6520/8520/6620/8620/6720/8720

**TABLE 26-25: A/D CONVERTER CHARACTERISTICS: PIC18FXX20 (INDUSTRIAL, EXTENDED)
PIC18LFX20 (INDUSTRIAL)**

Param No.	Symbol	Characteristic	Min	Typ	Max	Units	Conditions
A01	NR	Resolution	—	—	10	bit	
A03	EIL	Integral Linearity Error	—	—	<±1	LSb	VREF = VDD = 5.0V
A04	EDL	Differential Linearity Error	—	—	<±1	LSb	VREF = VDD = 5.0V
A05	Eg	Gain Error	—	—	<±1	LSb	VREF = VDD = 5.0V
A06	E _{OFF}	Offset Error	—	—	<±1.5	LSb	VREF = VDD = 5.0V
A10	—	Monotonicity	guaranteed ⁽²⁾			—	VSS ≤ VAIN ≤ VREF
A20	VREF	Reference Voltage	1.8V	—	—	V	VDD < 3.0V
A20A		(VREFH – VREFL)	3V	—	—	V	VDD ≥ 3.0V
A21	VREFH	Reference Voltage High	AVSS	—	AVDD + 0.3V	V	
A22	VREFL	Reference Voltage Low	AVSS – 0.3V ⁽⁵⁾	—	VREFH	V	
A25	VAIN	Analog Input Voltage	AVSS – 0.3V ⁽⁵⁾	—	AVDD + 0.3V ⁽⁵⁾	V	VDD ≥ 2.5V (Note 3)
A30	ZAIN	Recommended Impedance of Analog Voltage Source	—	—	2.5	kΩ	(Note 4)
A50	IREF	VREF Input Current (Note 1)	—	—	5 150	μA μA	During VAIN acquisition. During A/D conversion cycle.

Note 1: VSS ≤ VAIN ≤ VREF

2: The A/D conversion result never decreases with an increase in the input voltage and has no missing codes.

3: For VDD < 2.5V, VAIN should be limited to <.5 VDD.

4: Maximum allowed impedance for analog voltage source is 10 kΩ. This requires higher acquisition times.

5: |VDD – AVDD| must be <3.0V and |IAVSS – VSS| must be <0.3V.

FIGURE 26-26: A/D CONVERSION TIMING

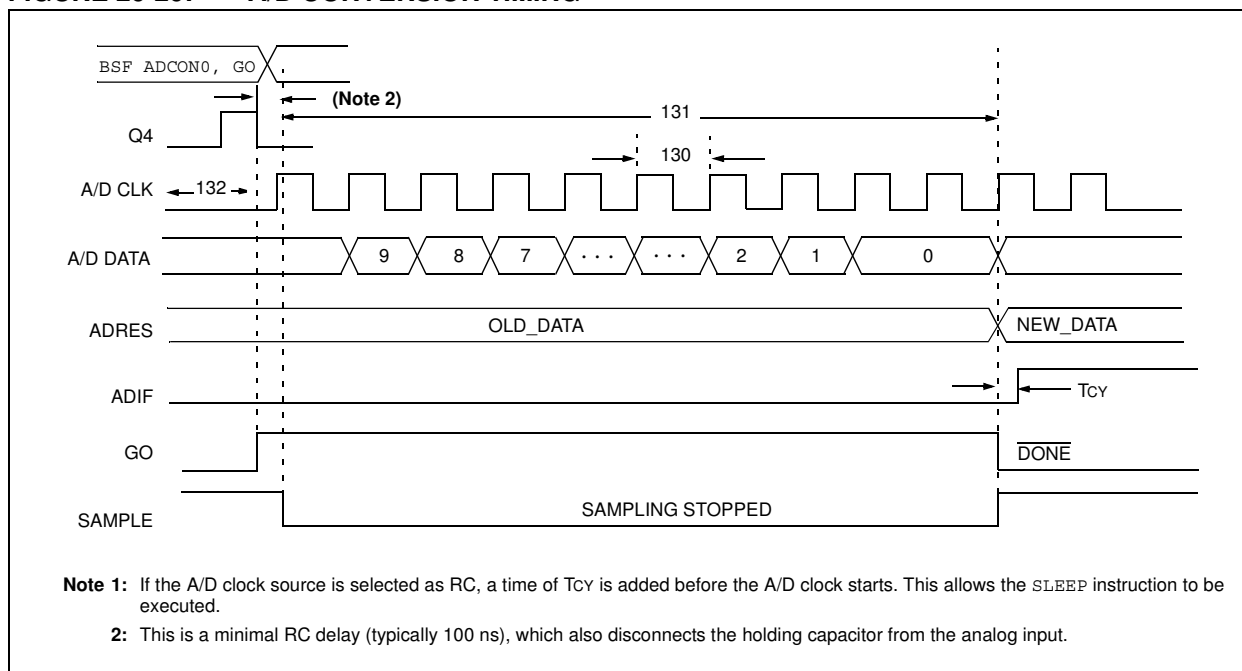

Note 1: If the A/D clock source is selected as RC, a time of T_{cy} is added before the A/D clock starts. This allows the SLEEP instruction to be executed.

2: This is a minimal RC delay (typically 100 ns), which also disconnects the holding capacitor from the analog input.

PIC18F6520/8520/6620/8620/6720/8720

TABLE 26-26: A/D CONVERSION REQUIREMENTS

Param No.	Symbol	Characteristic	Min	Max	Units	Conditions	
130	TAD	A/D Clock Period	PIC18FXX20	1.6	20 ⁽⁵⁾	μs	TOSC based, VREF ≥ 3.0V
			PIC18LFXX20	3.0	20 ⁽⁵⁾	μs	TOSC based, VREF full range
			PIC18FXX20	2.0	6.0	μs	A/D RC mode
			PIC18LFXX20	3.0	9.0	μs	A/D RC mode
131	TCNV	Conversion Time (not including acquisition time) (Note 1)	11	12	TAD		
132	TACQ	Acquisition Time (Note 3)	15	—	μs	-40°C ≤ Temp ≤ +125°C	
			10	—	μs	0°C ≤ Temp ≤ +125°C	
135	TSWC	Switching Time from Convert → Sample	—	(Note 4)			
136	TAMP	Amplifier Settling Time (Note 2)	1	—	μs	This may be used if the “new” input voltage has not changed by more than 1 LSb (i.e., 5 mV @ 5.12V) from the last sampled voltage (as stated on CHOLD).	

Note 1: ADRES register may be read on the following T_{CY} cycle.

- 2:** See **Section 19.0 “10-Bit Analog-to-Digital Converter (A/D) Module”** for minimum conditions when input voltage has changed more than 1 LSb.
- 3:** The time for the holding capacitor to acquire the “New” input voltage when the voltage changes full scale after the conversion (AVDD to AVSS, or AVSS to AVDD). The source impedance (*R_S*) on the input channels is 50Ω.
- 4:** On the next Q4 cycle of the device clock.
- 5:** The time of the A/D clock period is dependent on the device frequency and the TAD clock divider.

PIC18F6520/8520/6620/8620/6720/8720

NOTES:

PIC18F6520/8520/6620/8620/6720/8720

27.0 DC AND AC CHARACTERISTICS GRAPHS AND TABLES

Note: The graphs and tables provided following this note are a statistical summary based on a limited number of samples and are provided for informational purposes only. The performance characteristics listed herein are not tested or guaranteed. In some graphs or tables, the data presented may be outside the specified operating range (e.g., outside specified power supply range) and therefore, outside the warranted range.

“Typical” represents the mean of the distribution at 25°C. “Maximum” or “minimum” represents (mean + 3 σ) or (mean - 3 σ) respectively, where σ is a standard deviation, over the whole temperature range.

FIGURE 27-1: TYPICAL I_{DD} vs. F_{osc} OVER V_{DD} (HS MODE)

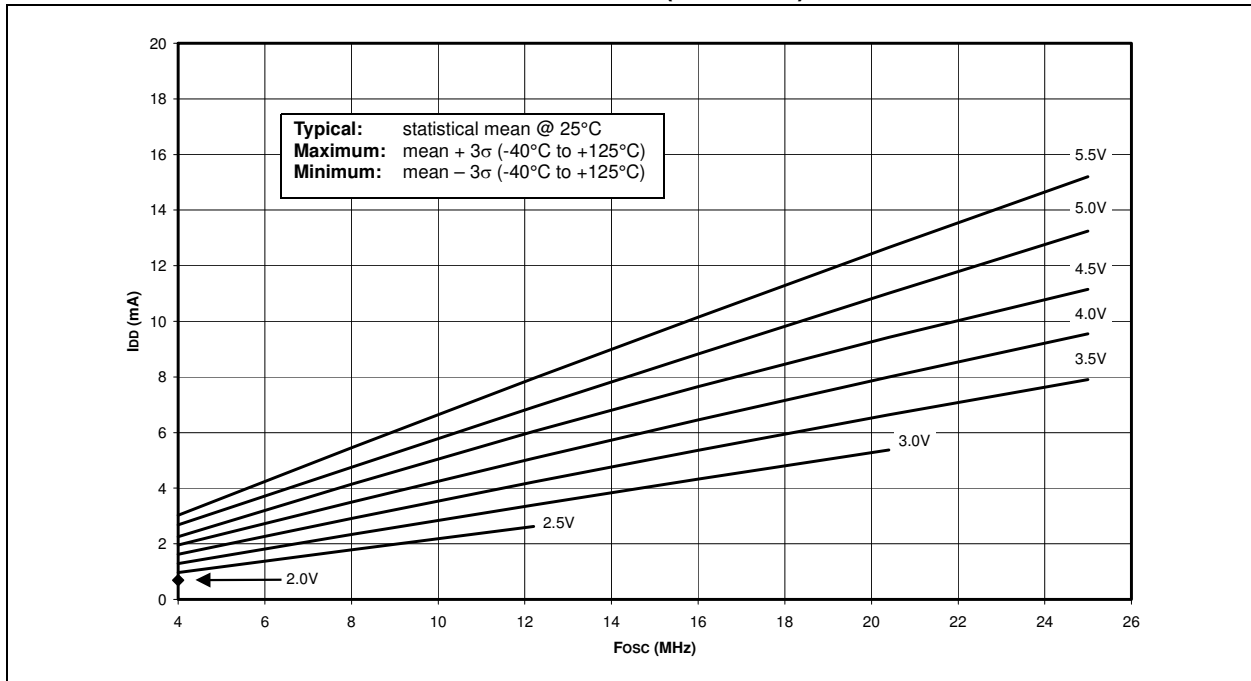
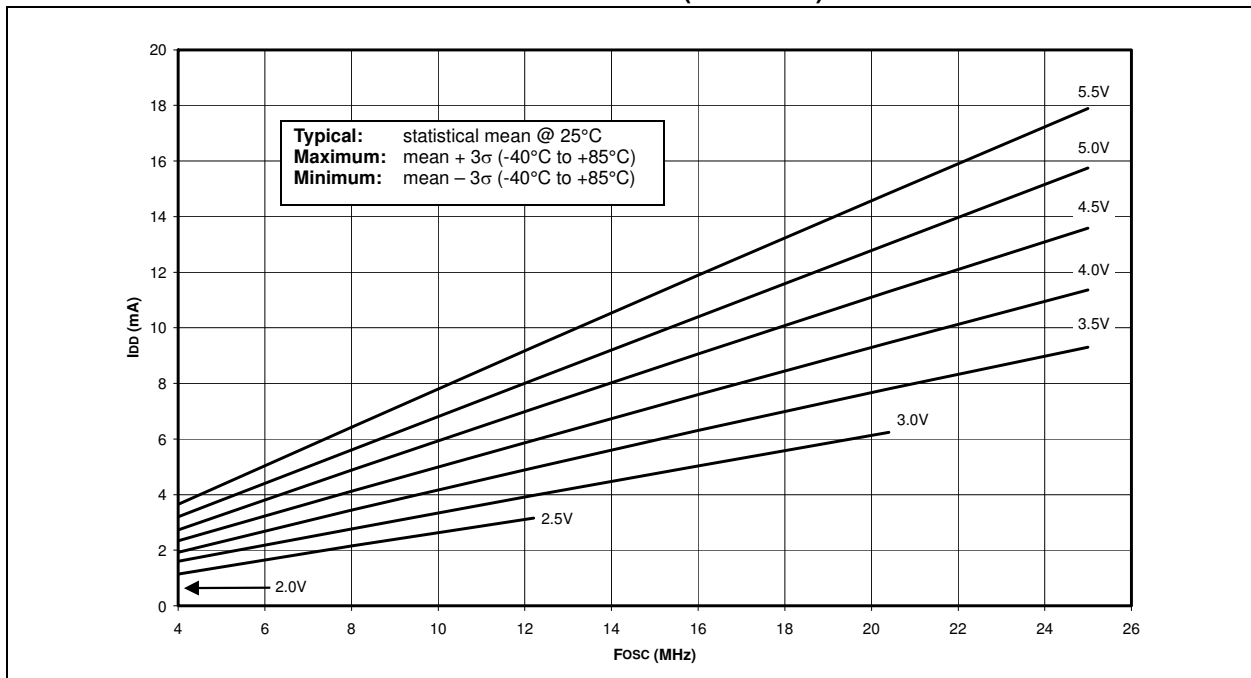

FIGURE 27-2: MAXIMUM I_{DD} vs. F_{osc} OVER V_{DD} (HS MODE) INDUSTRIAL



PIC18F6520/8520/6620/8620/6720/8720

FIGURE 27-3: MAXIMUM I_{DD} vs. F_{osc} OVER V_{DD} (HS MODE) EXTENDED

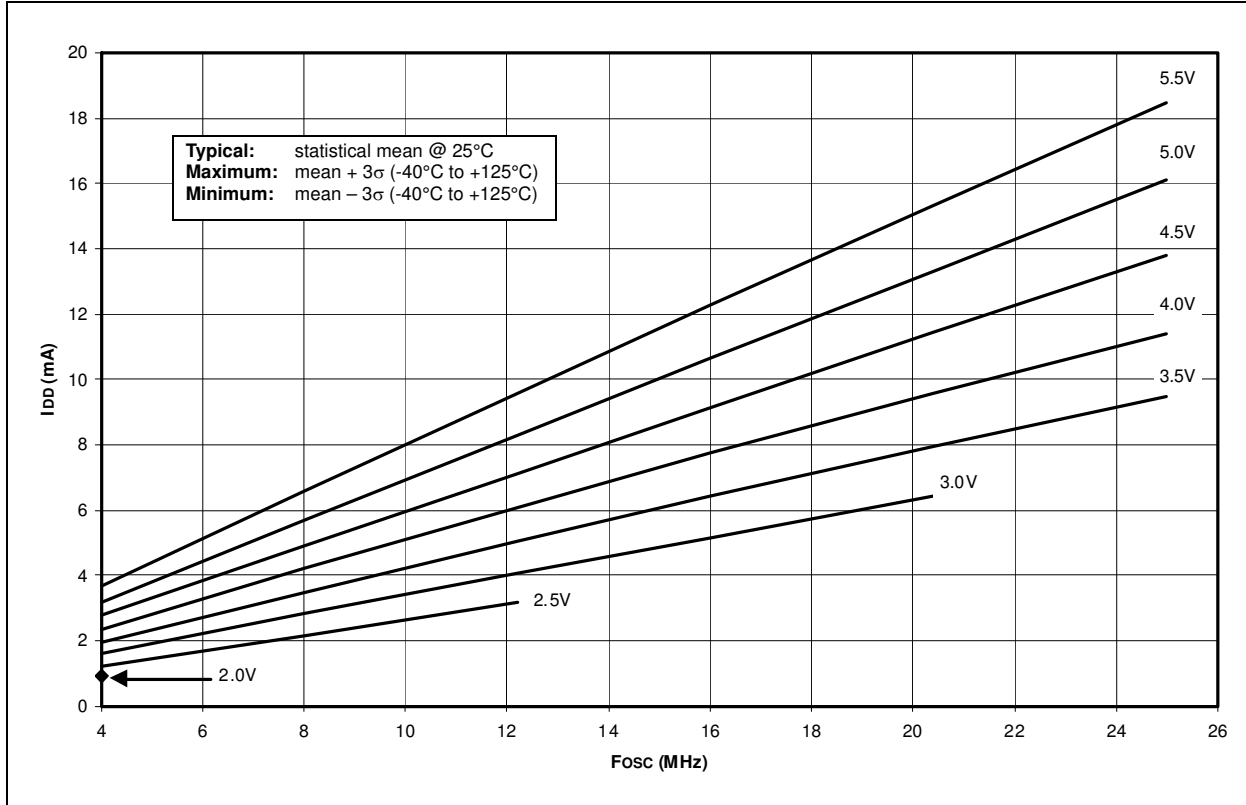
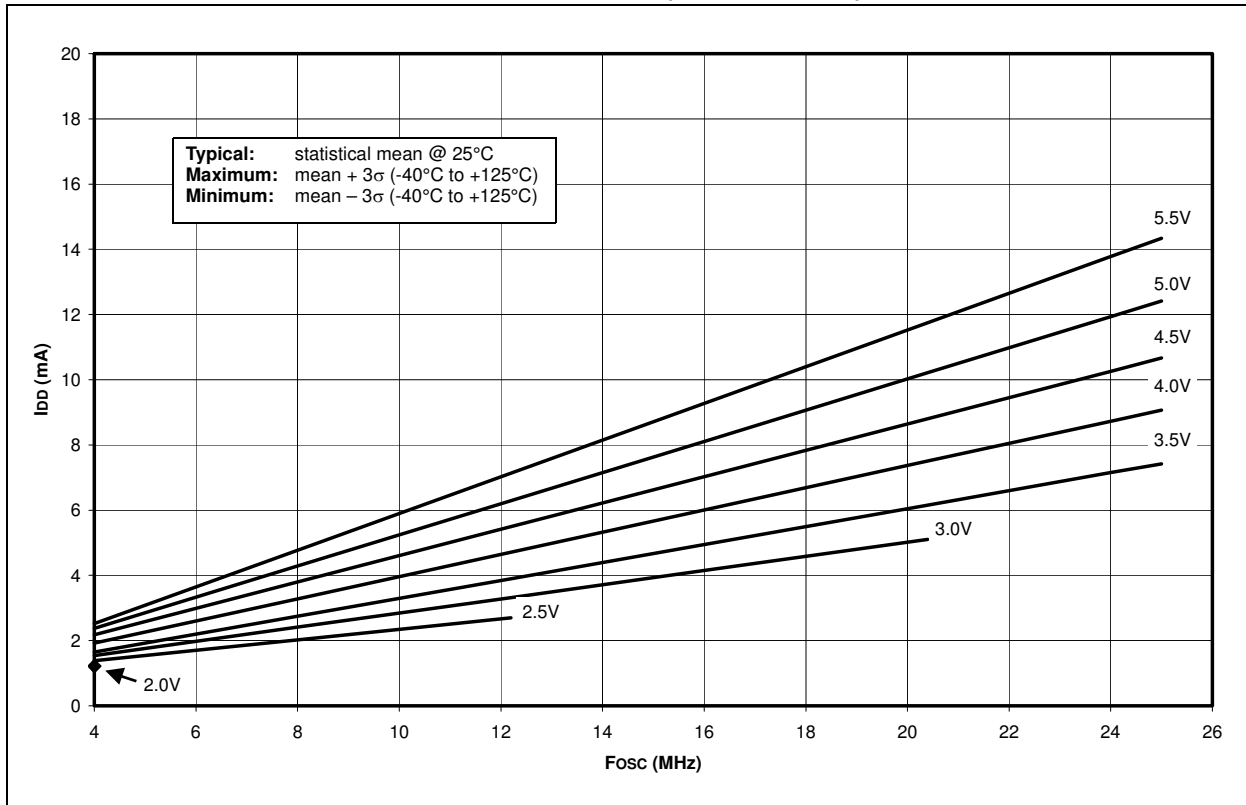

FIGURE 27-4: TYPICAL I_{DD} vs. F_{osc} OVER V_{DD} (HS/PLL MODE)



PIC18F6520/8520/6620/8620/6720/8720

FIGURE 27-5: MAXIMUM I_{DD} vs. Fosc OVER V_{DD} (HS/PLL MODE) INDUSTRIAL

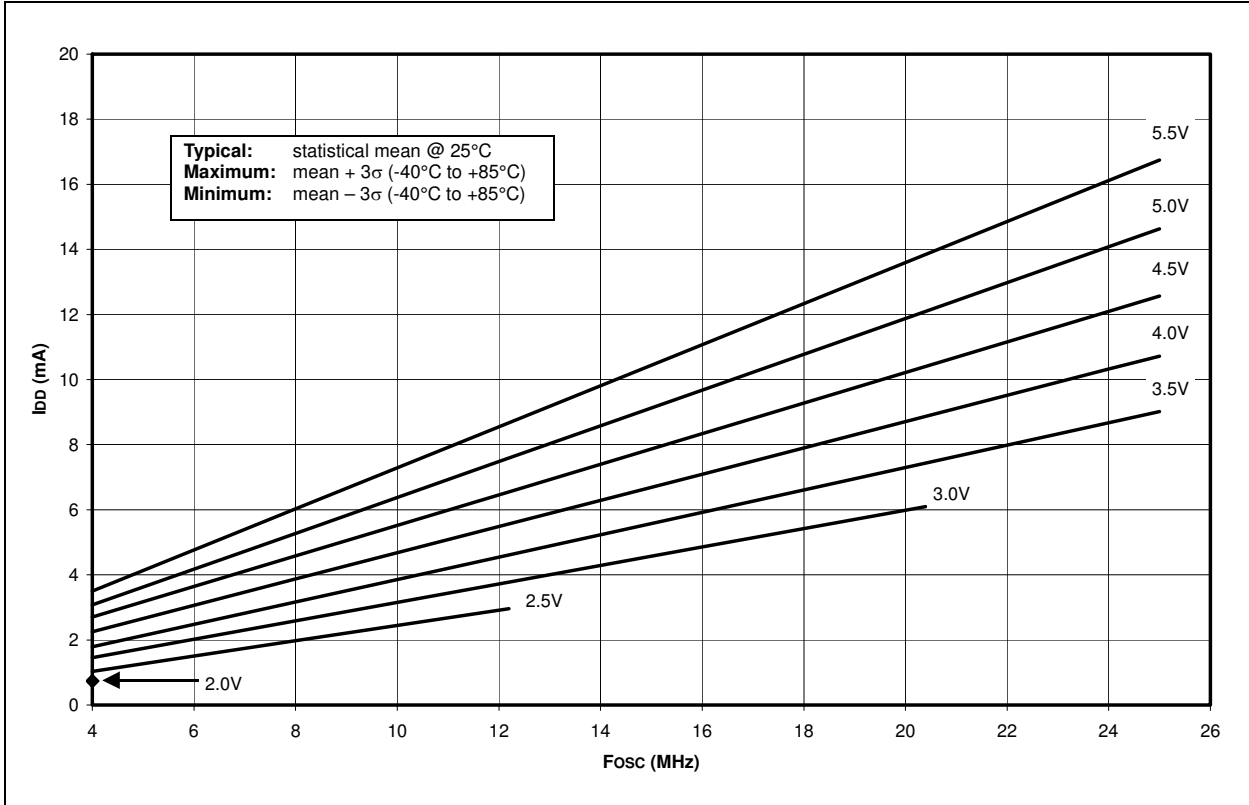
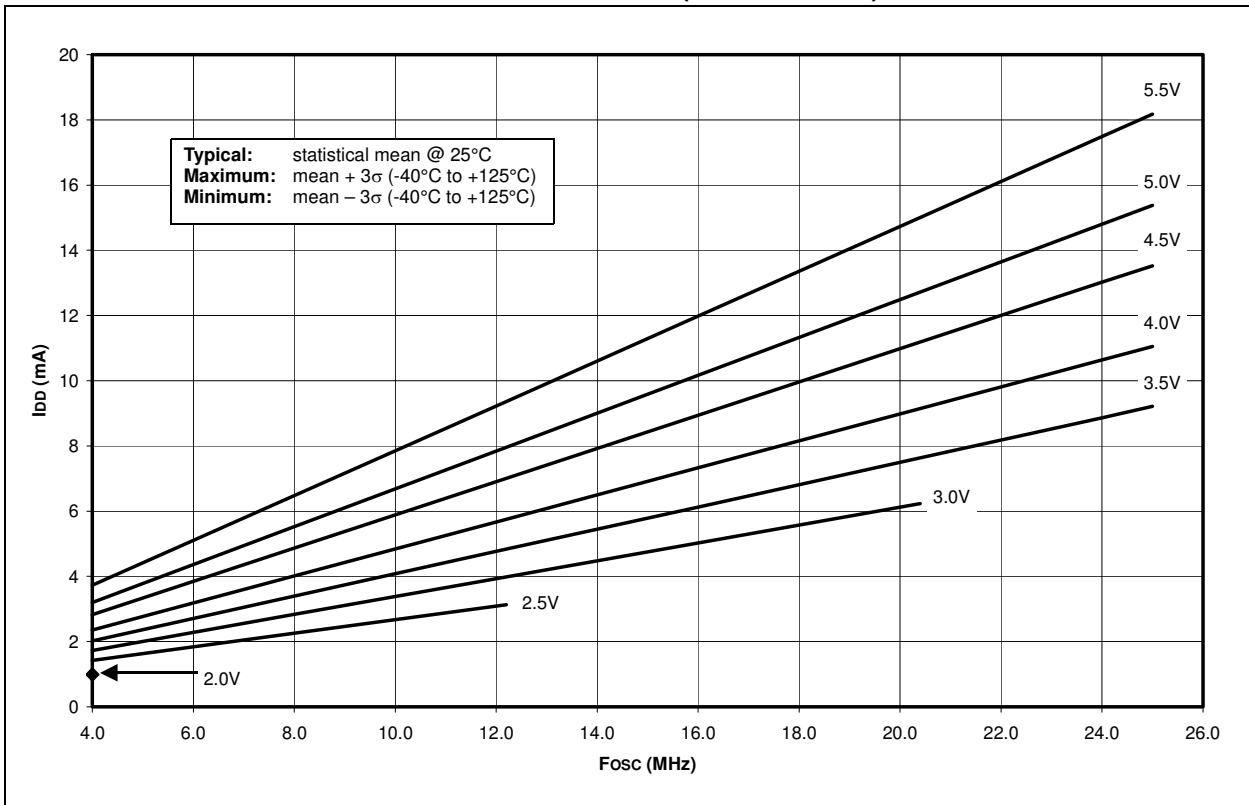

FIGURE 27-6: MAXIMUM I_{DD} vs. Fosc OVER V_{DD} (HS/PLL MODE) EXTENDED



PIC18F6520/8520/6620/8620/6720/8720

FIGURE 27-7: TYPICAL I_{DD} vs. F_{OSC} OVER V_{DD} (XT MODE)

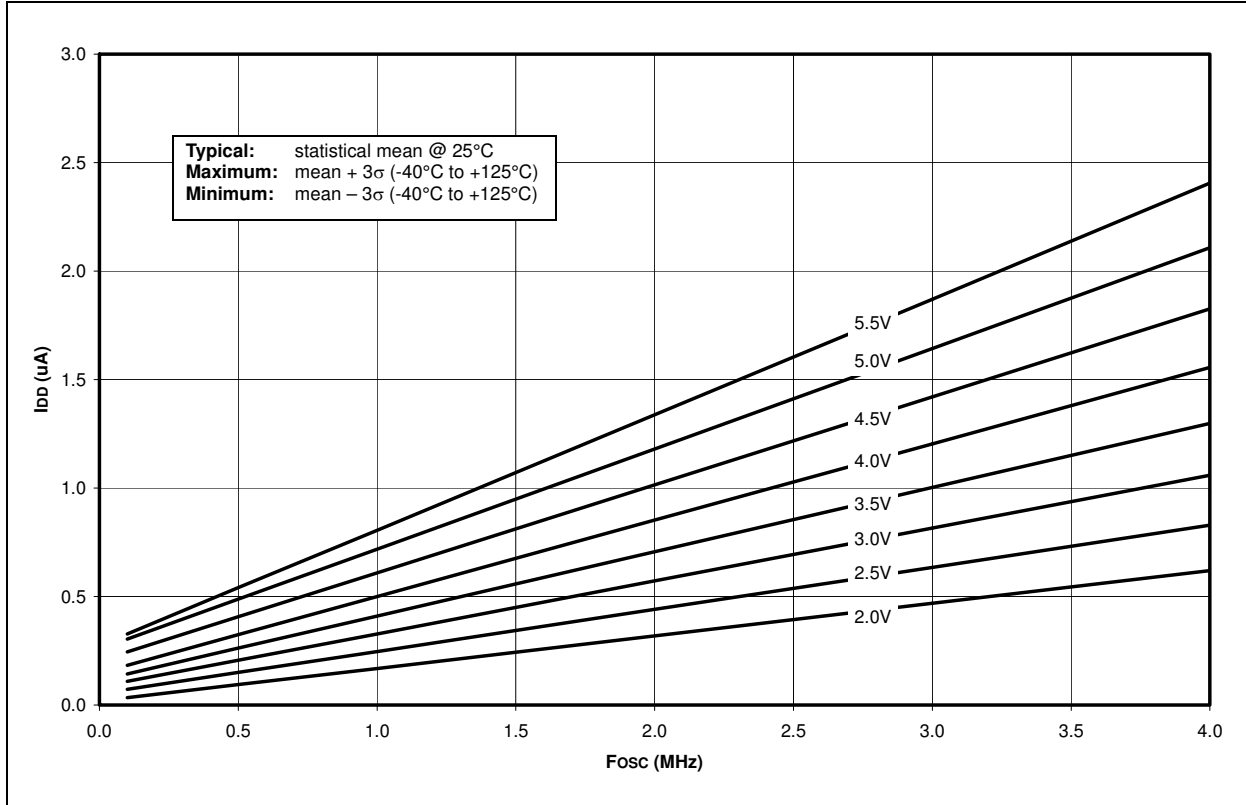
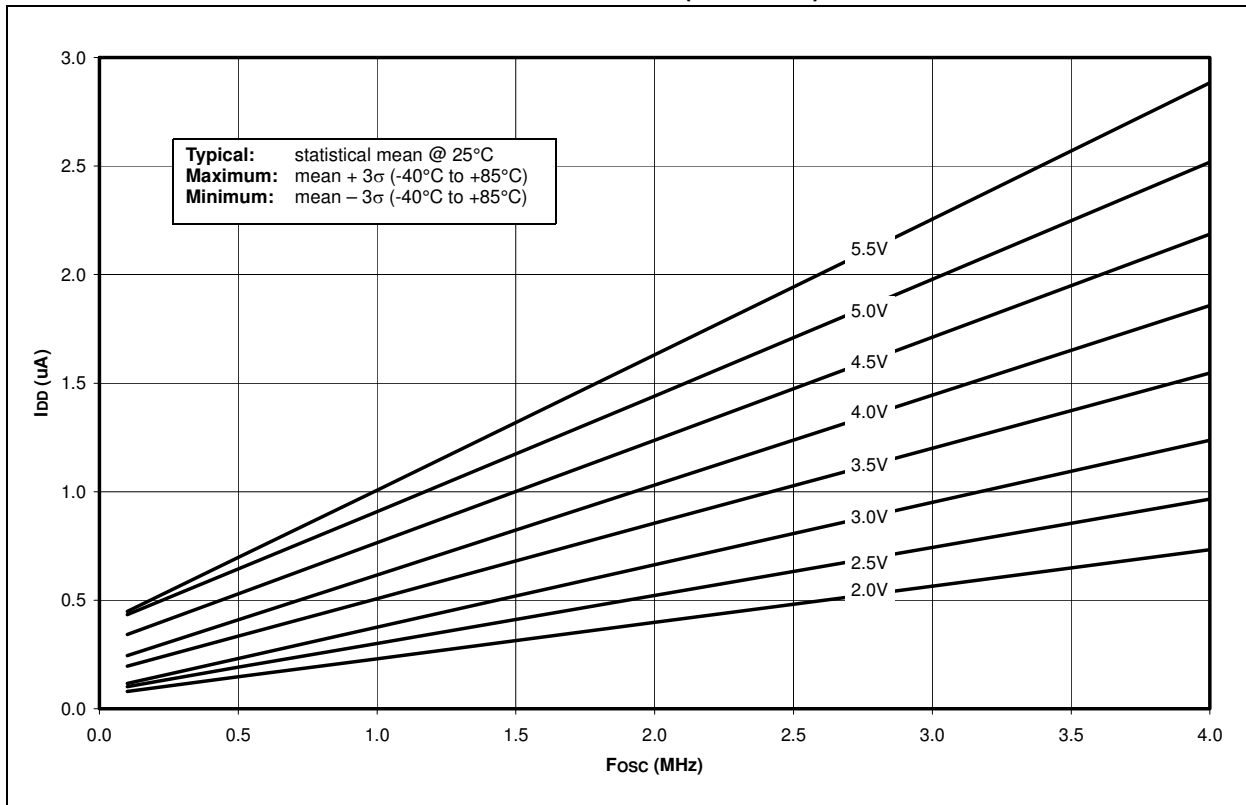

FIGURE 27-8: MAXIMUM I_{DD} vs. F_{OSC} OVER V_{DD} (XT MODE) INDUSTRIAL



PIC18F6520/8520/6620/8620/6720/8720

FIGURE 27-9: TYPICAL I_{DD} vs. F_{osc} OVER V_{DD} (LP MODE)

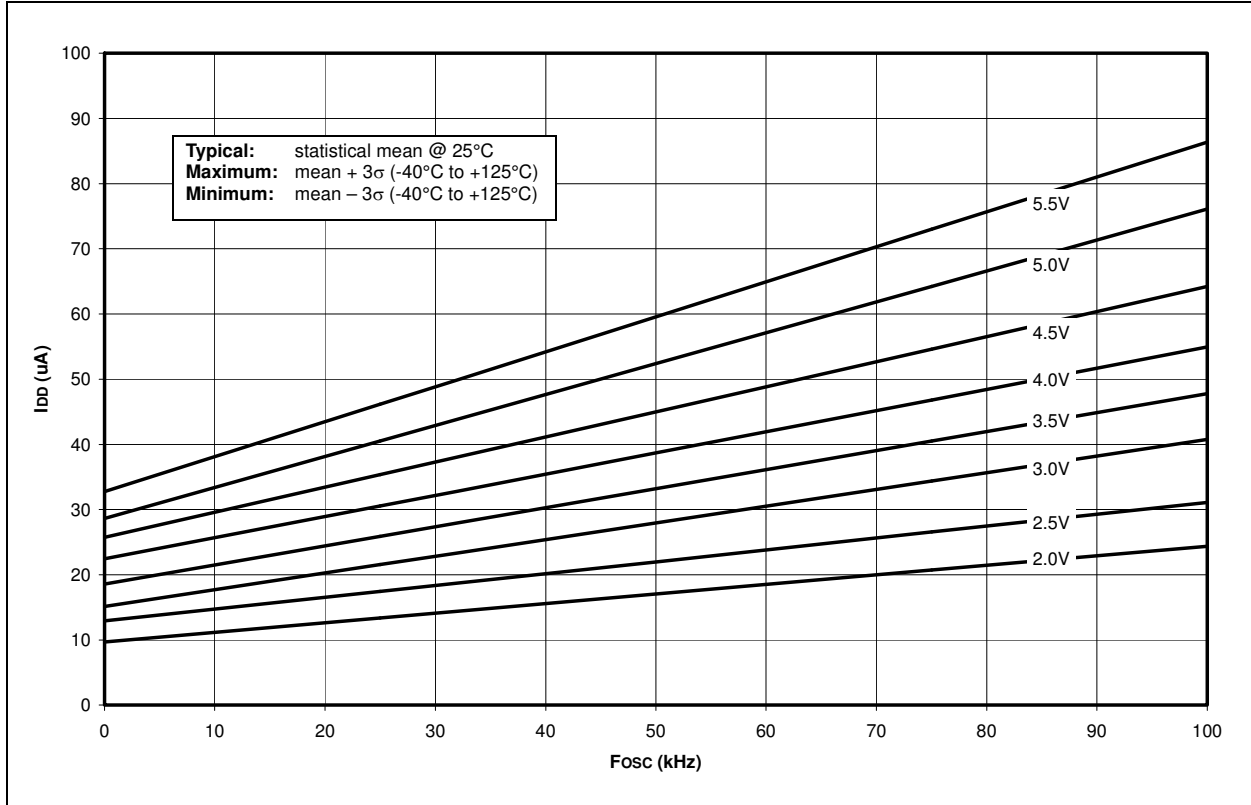
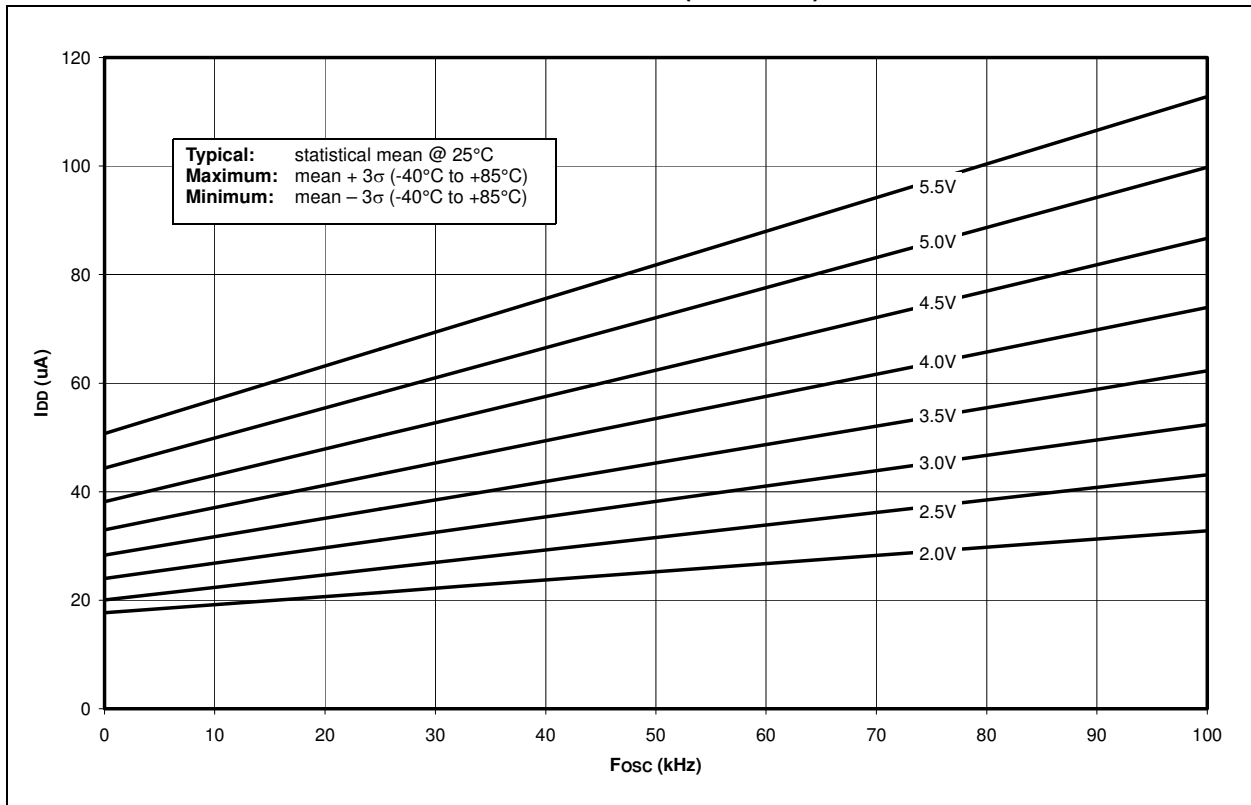

FIGURE 27-10: MAXIMUM I_{DD} vs. F_{osc} OVER V_{DD} (LP MODE) INDUSTRIAL



PIC18F6520/8520/6620/8620/6720/8720

FIGURE 27-11: MAXIMUM I_{DD} vs. Fosc OVER V_{DD} (LP MODE) EXTENDED

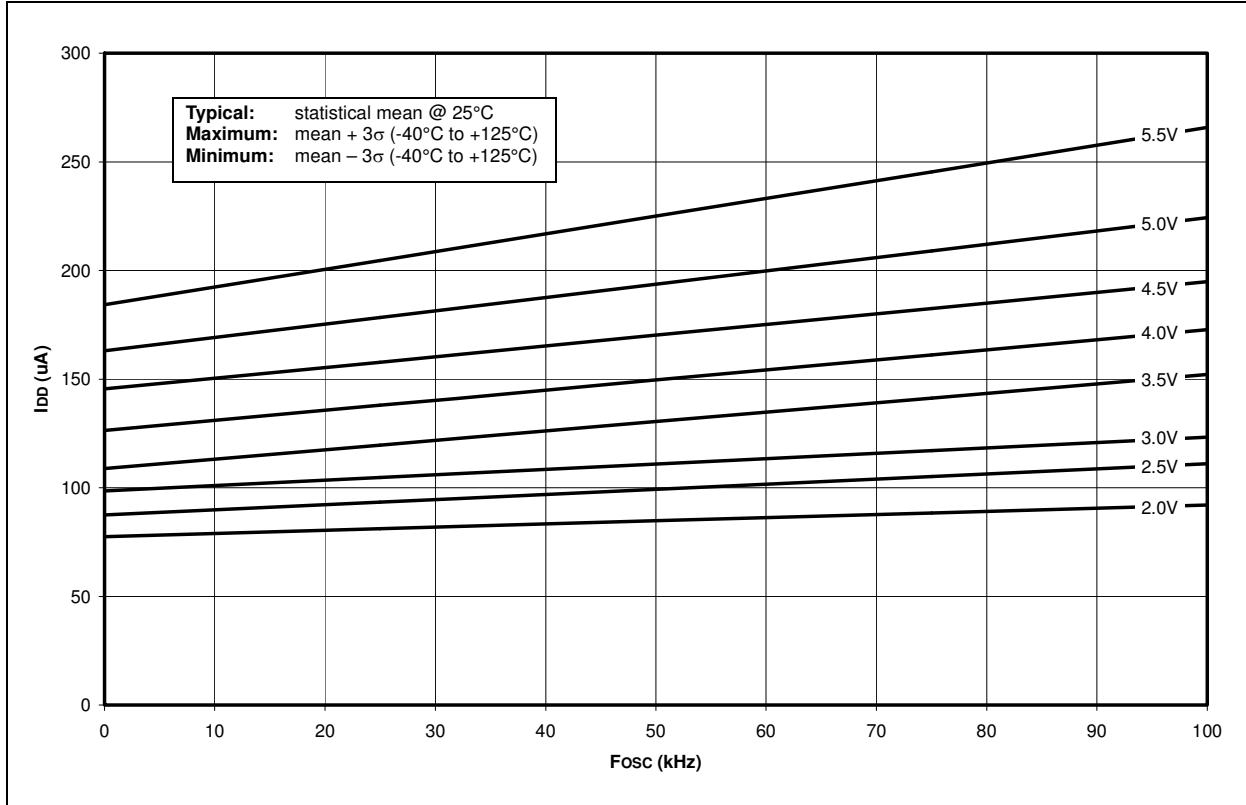
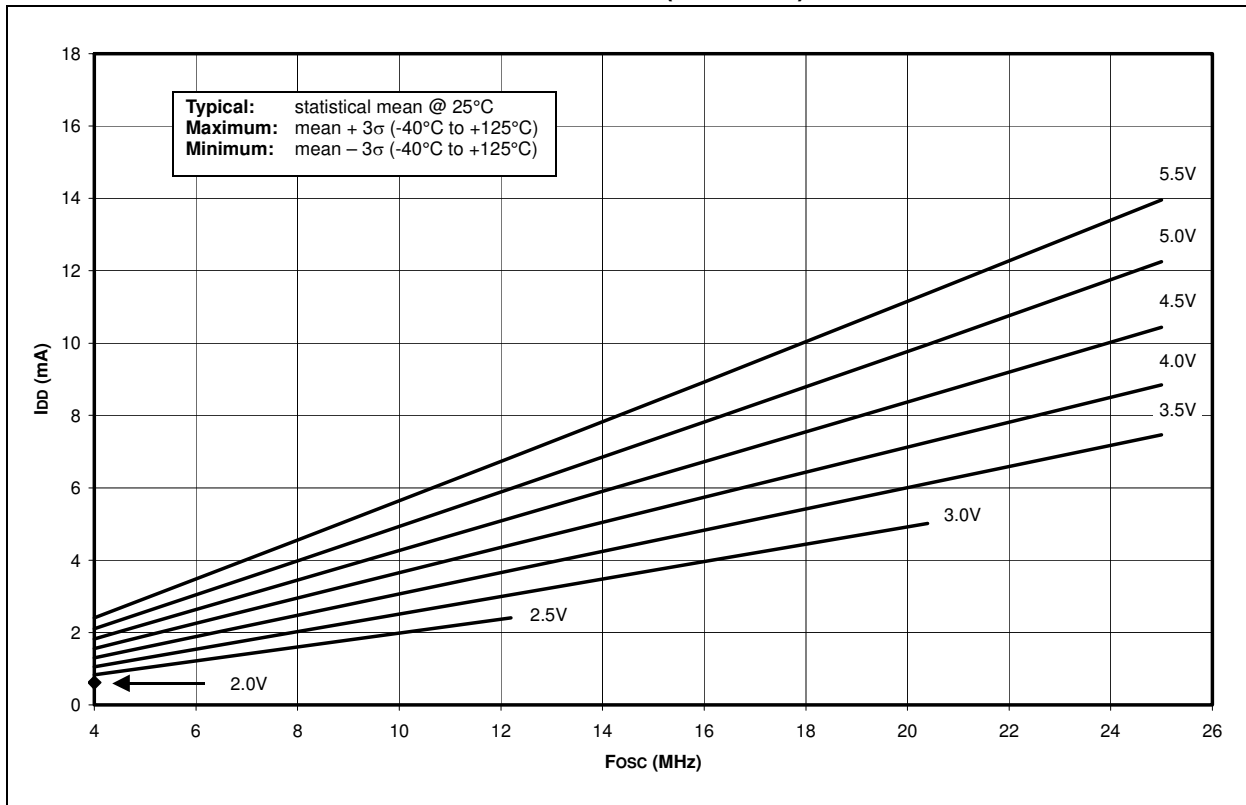

FIGURE 27-12: TYPICAL I_{DD} vs. Fosc OVER V_{DD} (EC MODE)



PIC18F6520/8520/6620/8620/6720/8720

FIGURE 27-13: MAXIMUM I_{DD} vs. Fosc OVER V_{DD} (EC MODE)

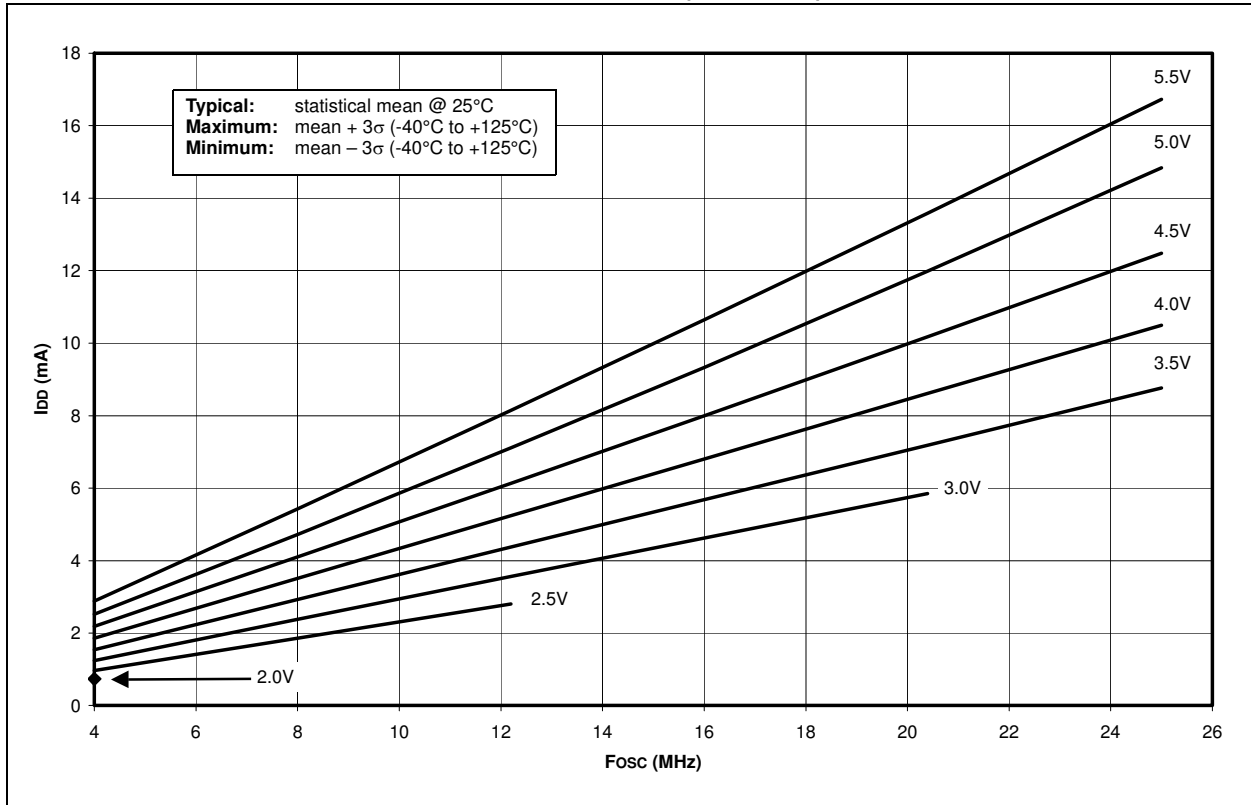
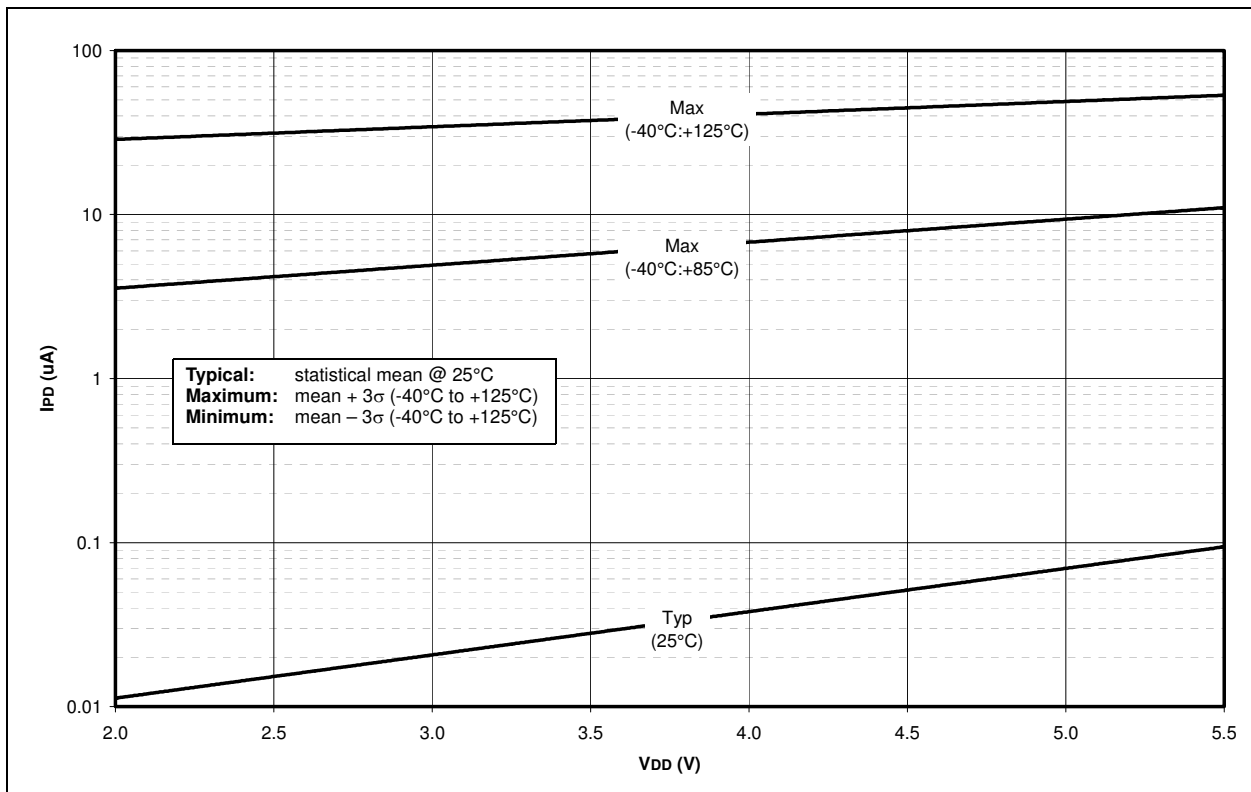

FIGURE 27-14: MAXIMUM I_{PD} vs. V_{DD} OVER TEMPERATURE



PIC18F6520/8520/6620/8620/6720/8720

FIGURE 27-15: TYPICAL AND MAXIMUM I_{PD} vs. V_{DD} OVER TEMPERATURE (TIMER1 AS MAIN OSCILLATOR, 32.768 kHz, C1 AND C2 = 47 pF)

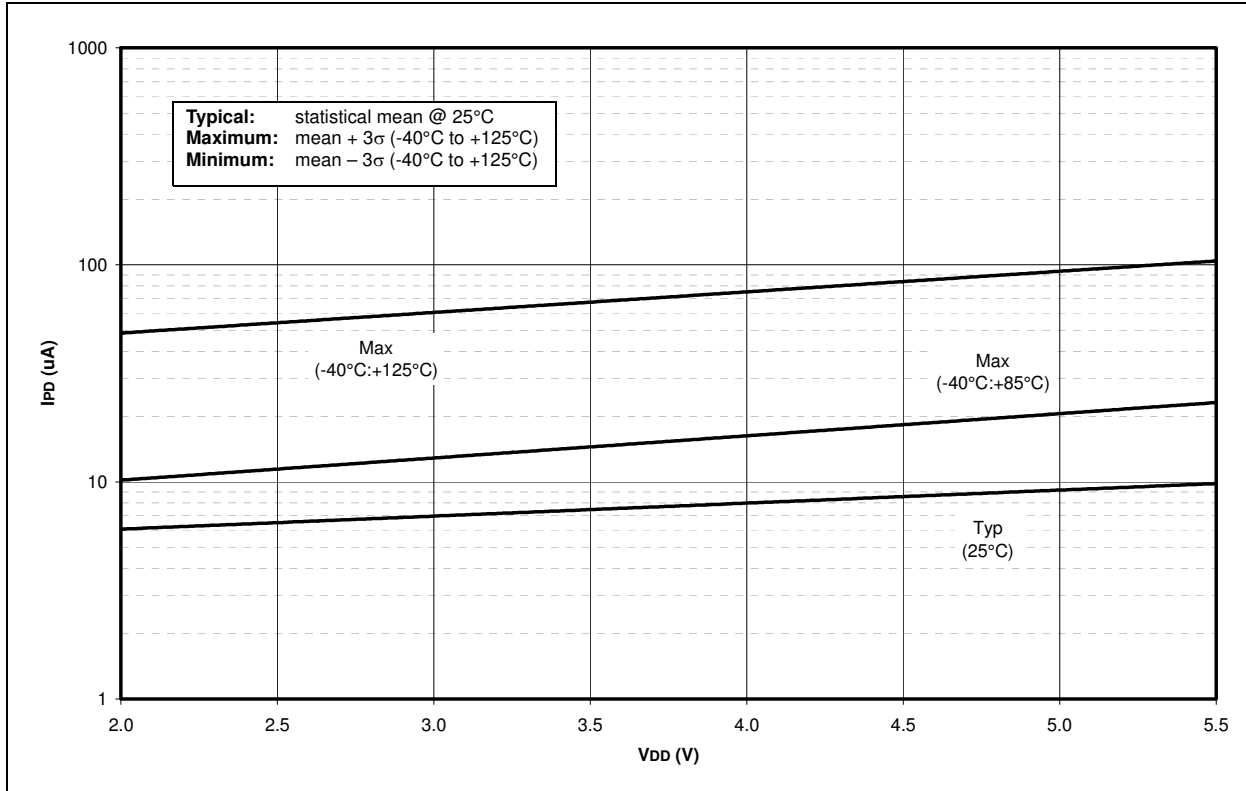
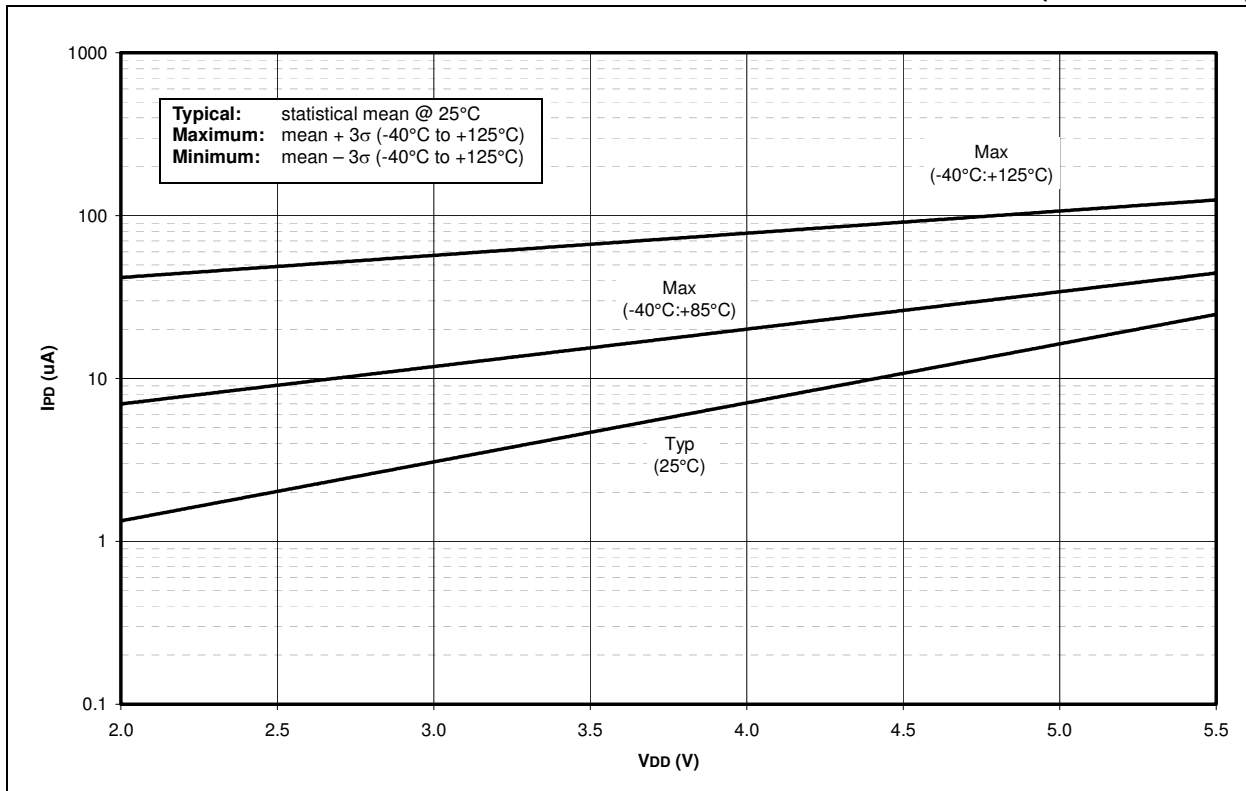

FIGURE 27-16: TYPICAL AND MAXIMUM ΔI_{WDT} vs. V_{DD} OVER TEMPERATURE (WDT ENABLED)



PIC18F6520/8520/6620/8620/6720/8720

FIGURE 27-17: TYPICAL I_{DD} vs. F_{osc} OVER V_{DD} (EC MODE)

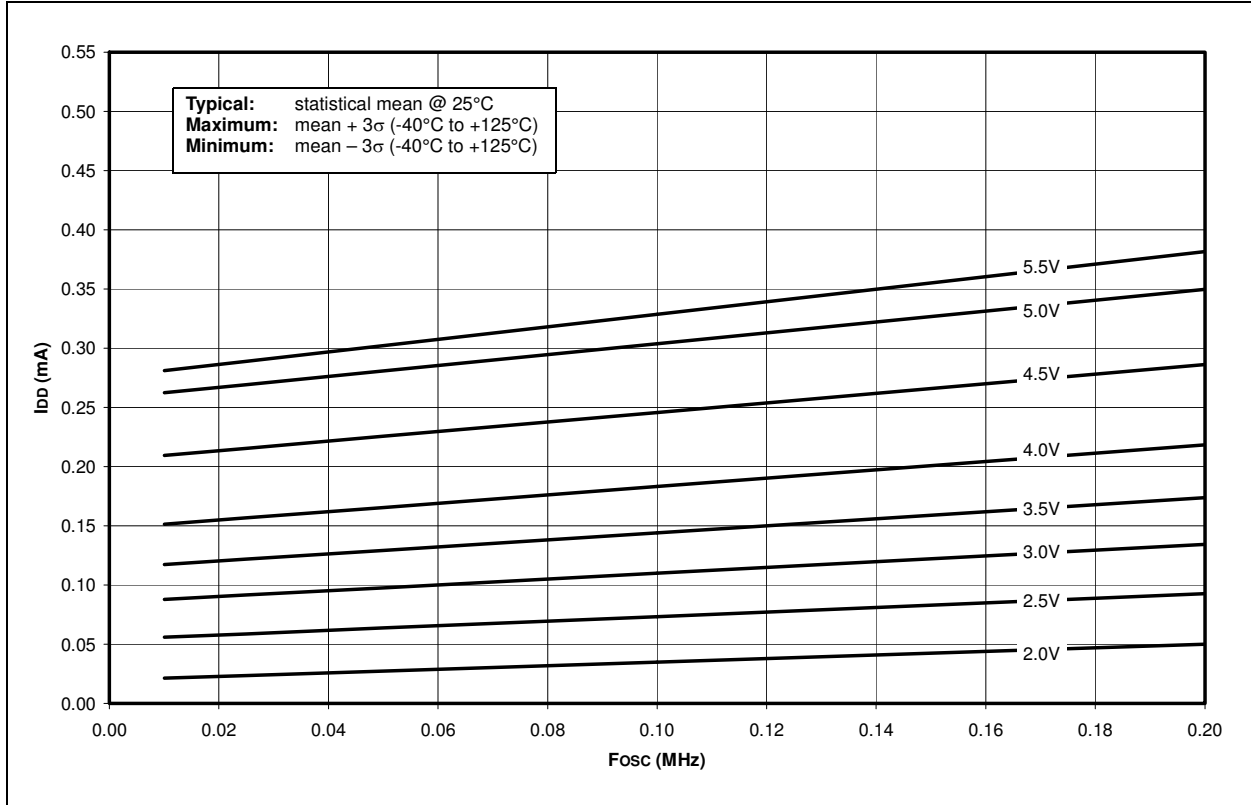
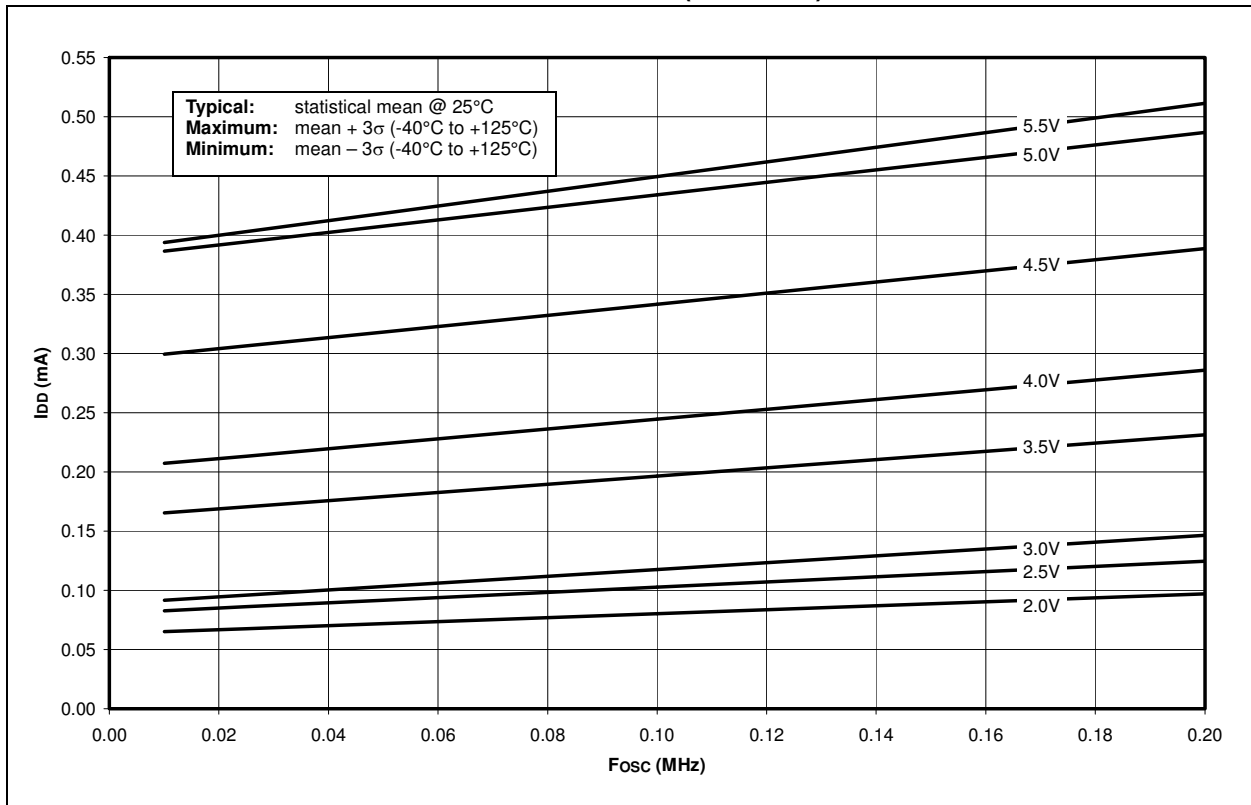

FIGURE 27-18: MAXIMUM I_{DD} vs. F_{osc} OVER V_{DD} (EC MODE)



PIC18F6520/8520/6620/8620/6720/8720

FIGURE 27-19: TYPICAL I_{DD} vs. F_{osc} OVER V_{DD} (EC MODE) (PIC18F8520 DEVICES ONLY)

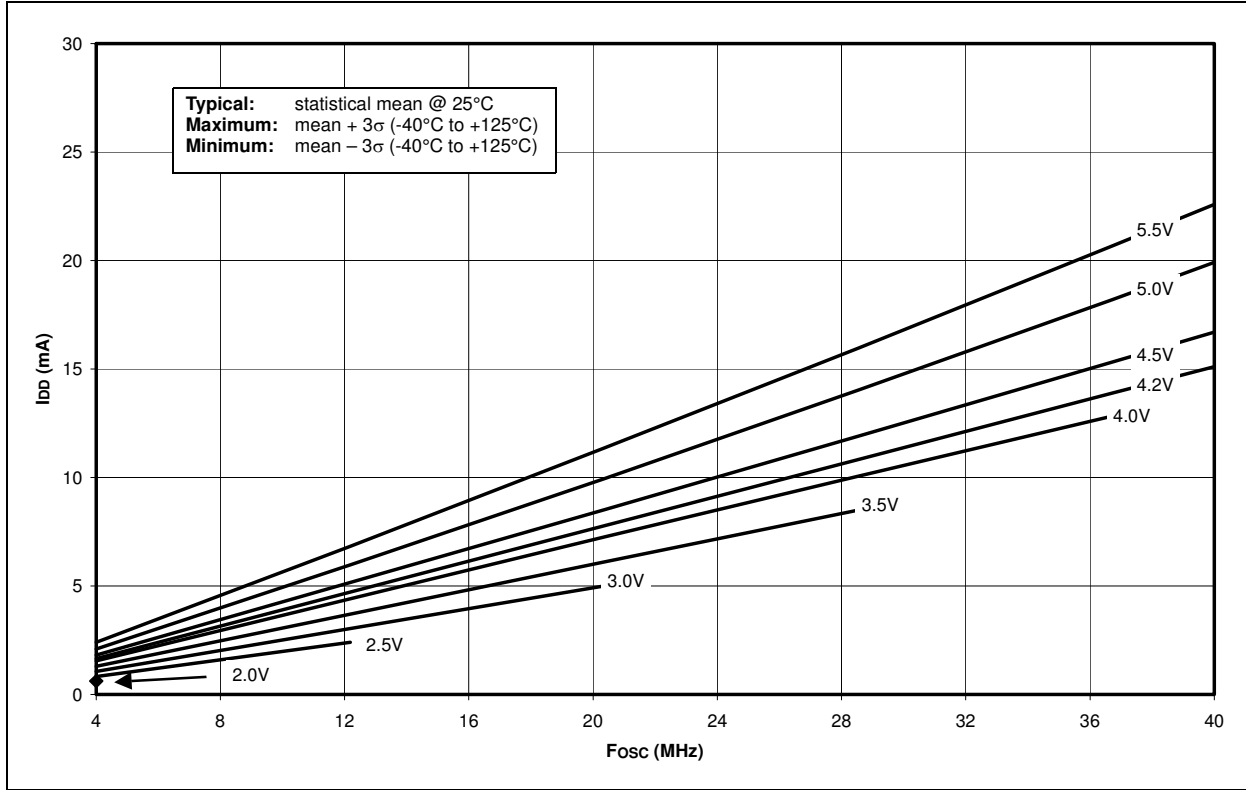
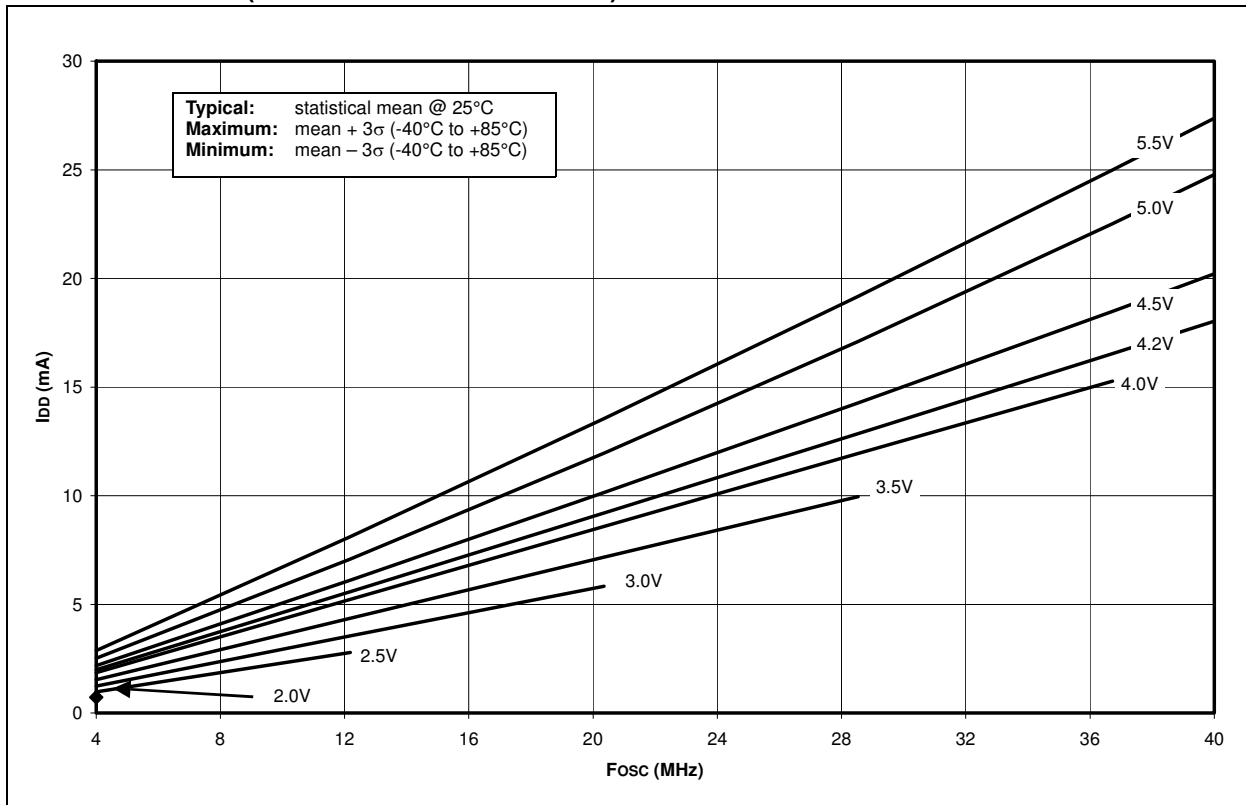

FIGURE 27-20: MAXIMUM I_{DD} vs. F_{osc} OVER V_{DD} (EC MODE) INDUSTRIAL (PIC18F8520 DEVICES ONLY)



PIC18F6520/8520/6620/8620/6720/8720

FIGURE 27-21: MAXIMUM I_{DD} vs. F_{osc} OVER V_{DD} (EC MODE) EXTENDED (PIC18F8520 DEVICES ONLY)

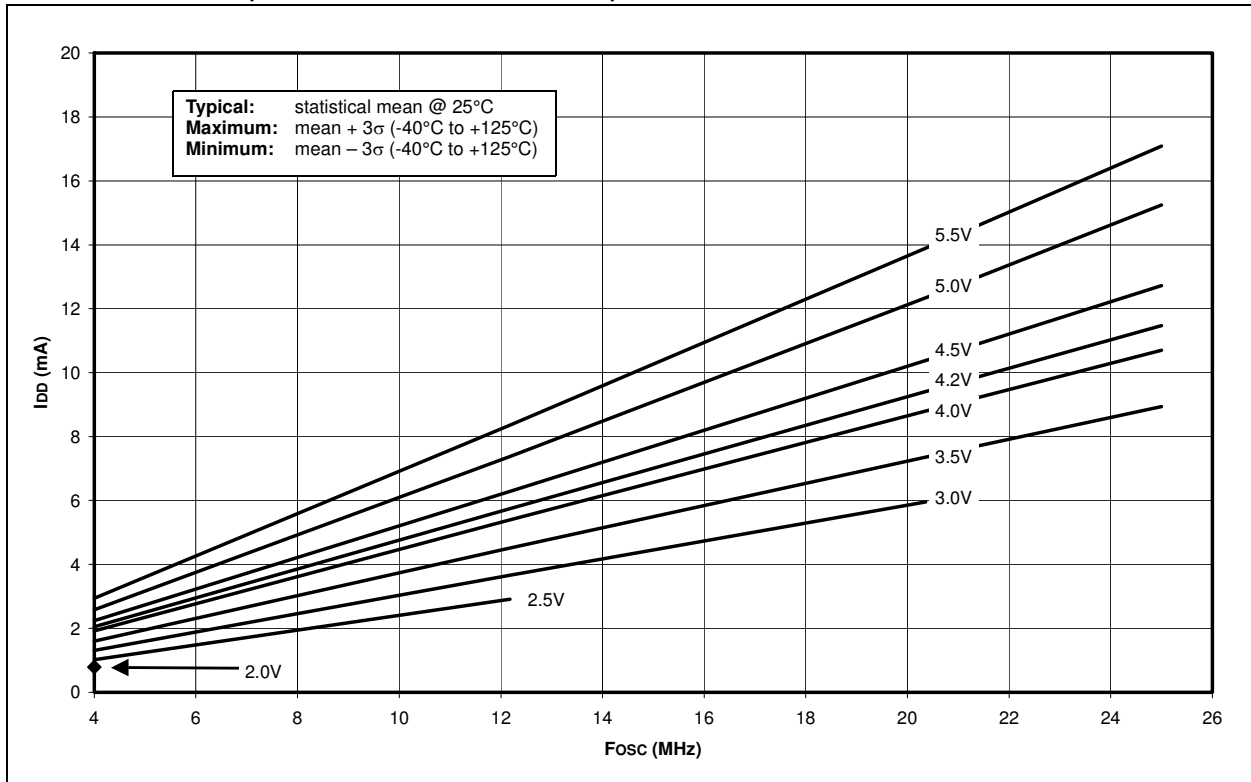
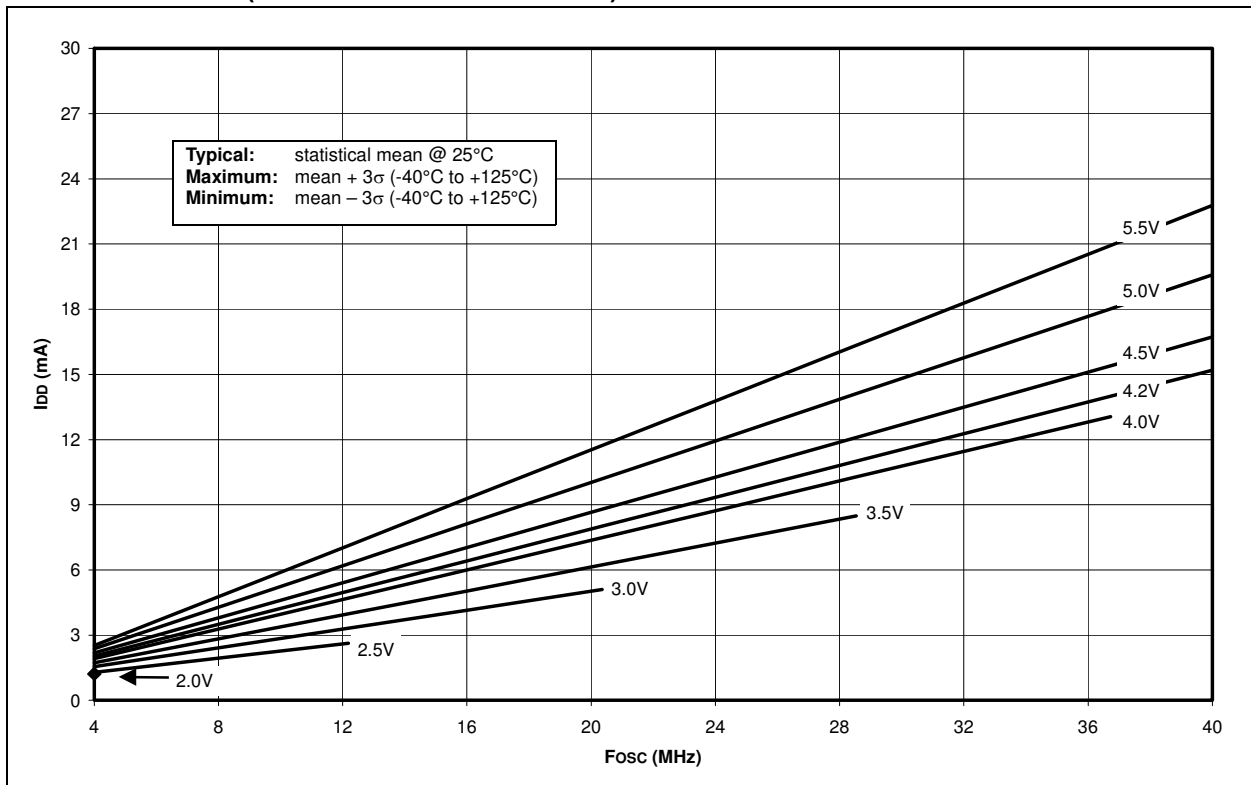

FIGURE 27-22: TYPICAL I_{DD} vs. F_{osc} OVER V_{DD} (HS/PLL MODE) (PIC18F8520 DEVICES ONLY)



PIC18F6520/8520/6620/8620/6720/8720

FIGURE 27-23: MAXIMUM I_{DD} vs. Fosc OVER V_{DD} (HS/PLL MODE) INDUSTRIAL (PIC18F8520 DEVICES ONLY)

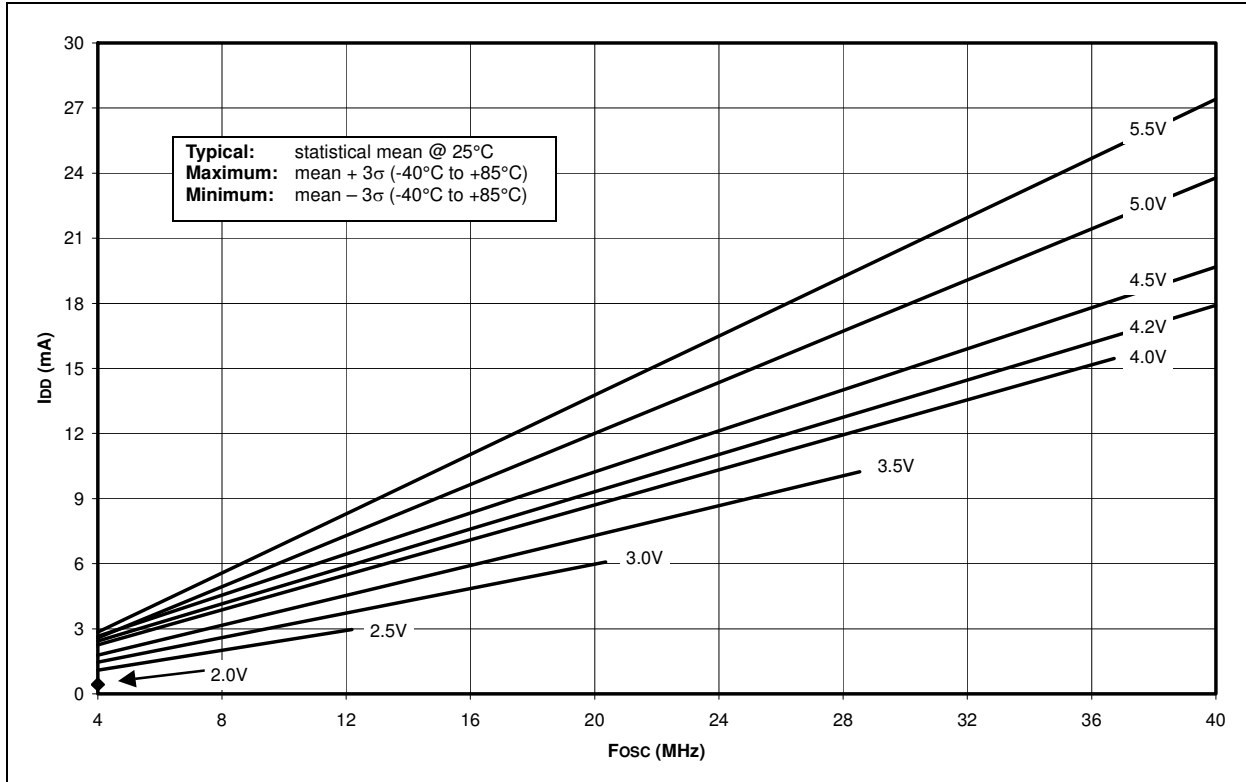
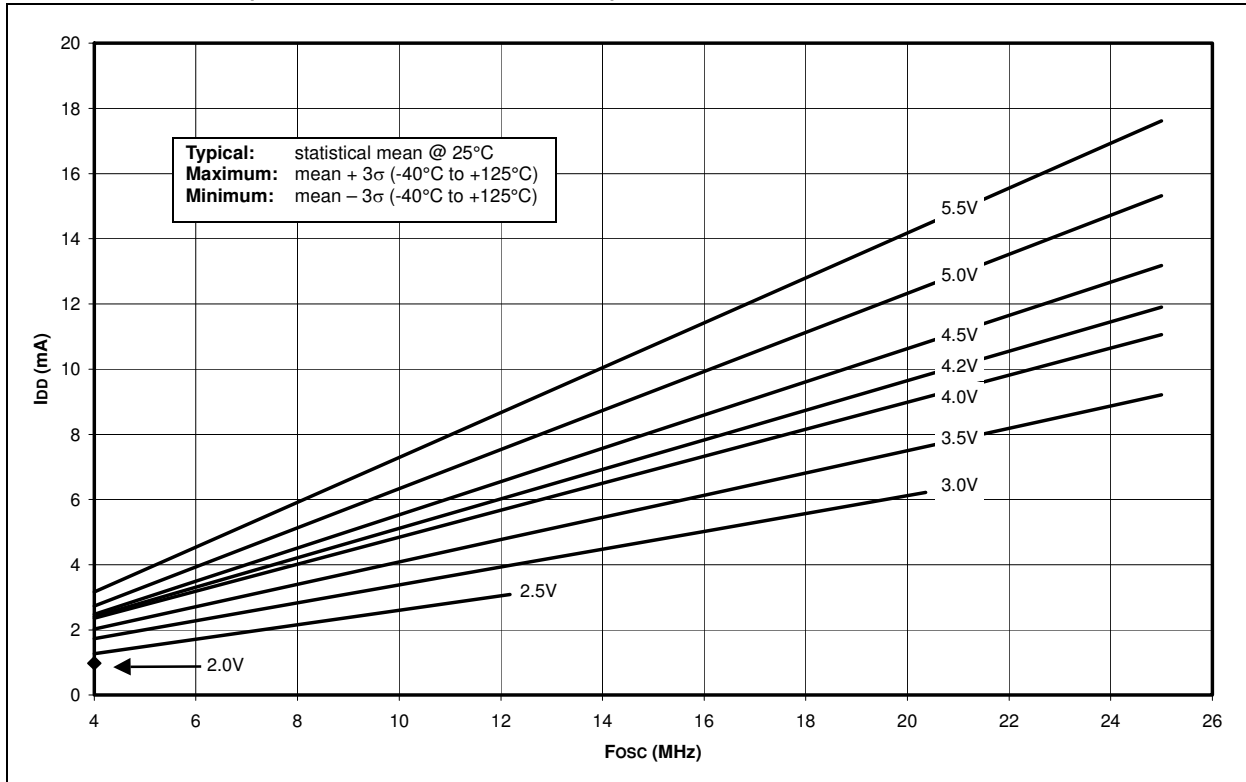

FIGURE 27-24: MAXIMUM I_{DD} vs. Fosc OVER V_{DD} (HS/PLL MODE) EXTENDED (PIC18F8520 DEVICES ONLY)



PIC18F6520/8520/6620/8620/6720/8720

FIGURE 27-25: A/D NONLINEARITY vs. VREFH (VDD = VREFH, -40°C TO +125°C)

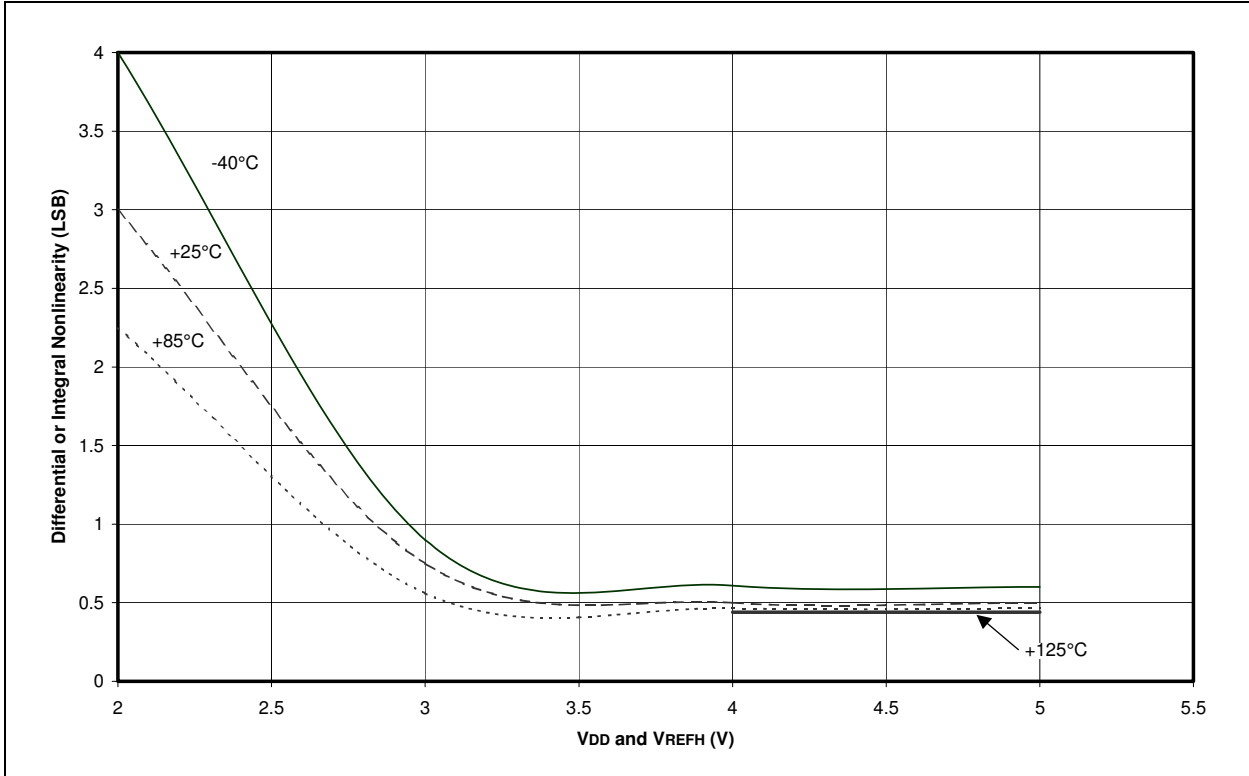
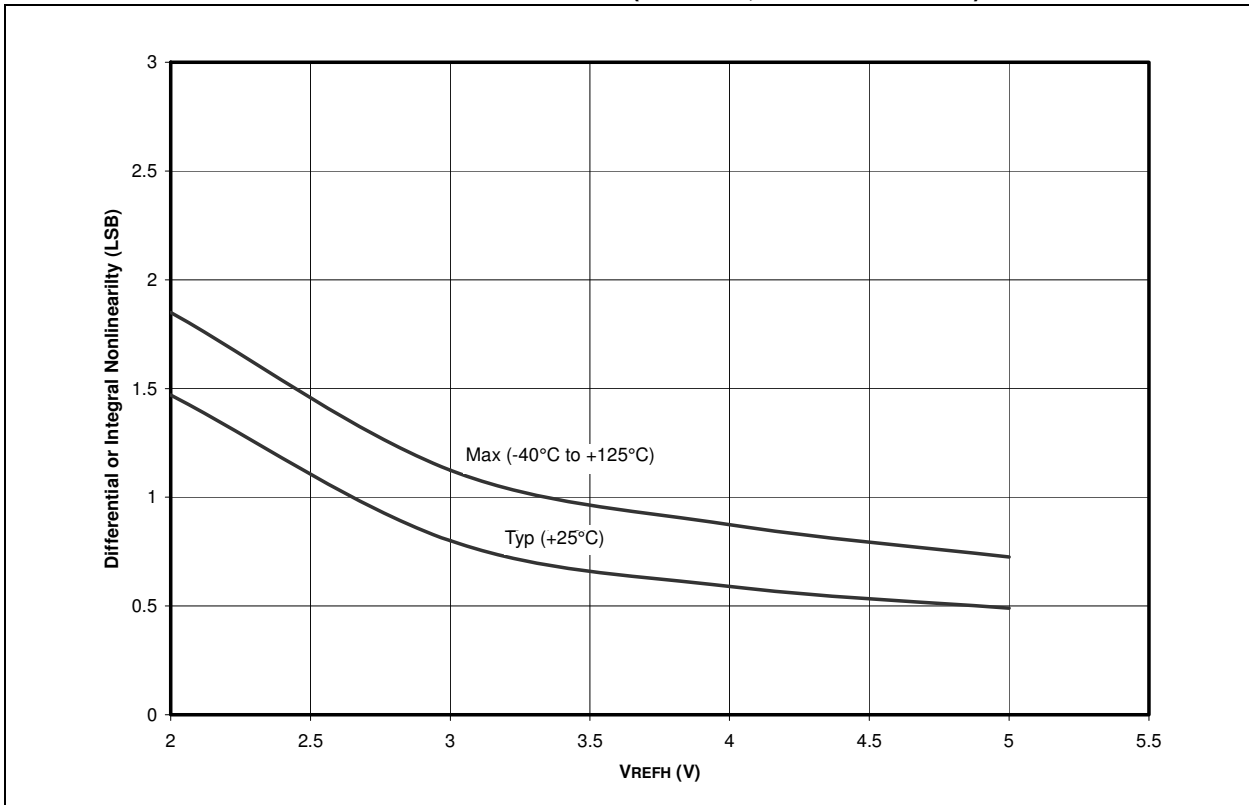

FIGURE 27-26: A/D NONLINEARITY vs. VREFH (VDD = 5V, -40°C TO +125°C)



PIC18F6520/8520/6620/8620/6720/8720

NOTES:

PIC18F6520/8520/6620/8620/6720/8720

28.0 PACKAGING INFORMATION

28.1 Package Marking Information

64-Lead TQFP (10x10x1 mm)

Example

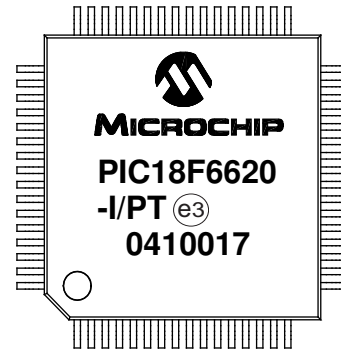
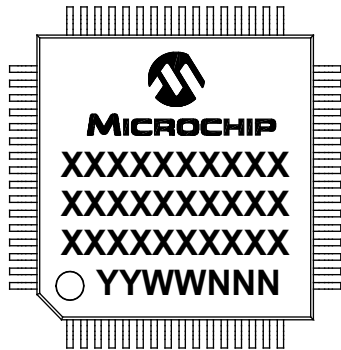

80-Lead TQFP (12x12x1 mm)

Example

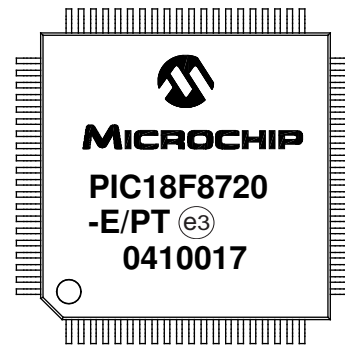
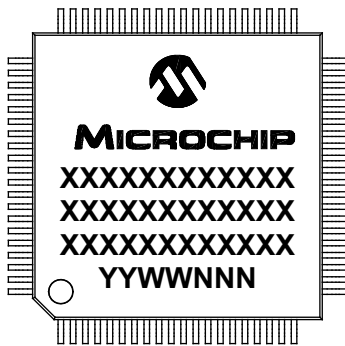

Legend:	XX...X	Customer-specific information
	Y	Year code (last digit of calendar year)
	YY	Year code (last 2 digits of calendar year)
	WW	Week code (week of January 1 is week '01')
	NNN	Alphanumeric traceability code
	(e3)	Pb-free JEDEC designator for Matte Tin (Sn)
	*	This package is Pb-free. The Pb-free JEDEC designator (e3) can be found on the outer packaging for this package.

Note: In the event the full Microchip part number cannot be marked on one line, it will be carried over to the next line, thus limiting the number of available characters for customer-specific information.

PIC18F6520/8520/6620/8620/6720/8720

28.2 Package Details

The following sections give the technical details of the packages.

64-Lead Plastic Thin Quad Flatpack (PT) – 10x10x1 mm Body, 2.00 mm [TQFP]

Note: For the most current package drawings, please see the Microchip Packaging Specification located at <http://www.microchip.com/packaging>

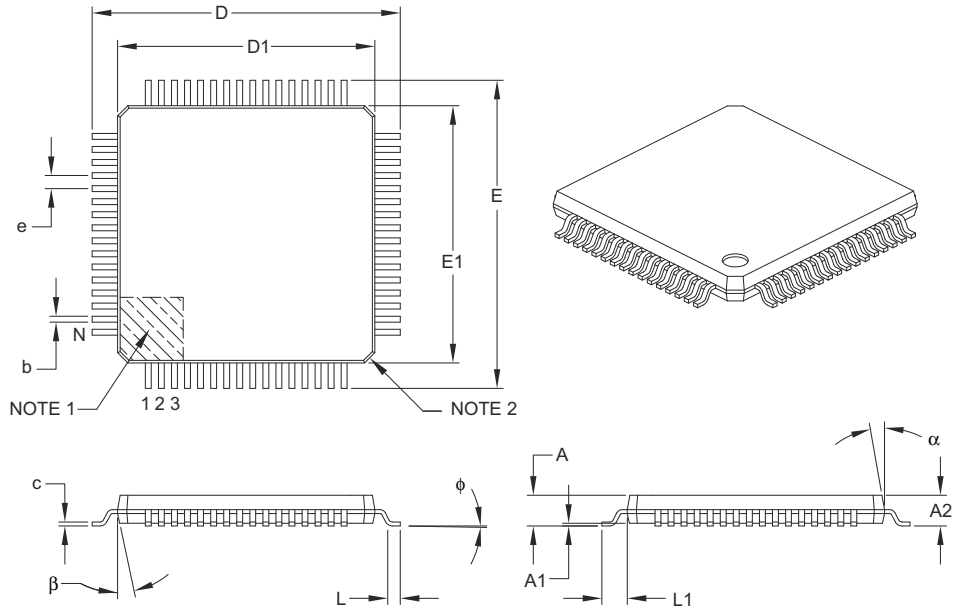

Dimension Limits	Units	MILLIMETERS		
		MIN	NOM	MAX
Number of Leads	N	64		
Lead Pitch	e	0.50 BSC		
Overall Height	A	–	–	1.20
Molded Package Thickness	A2	0.95	1.00	1.05
Standoff	A1	0.05	–	0.15
Foot Length	L	0.45	0.60	0.75
Footprint	L1	1.00 REF		
Foot Angle	ϕ	0°	3.5°	7°
Overall Width	E	12.00 BSC		
Overall Length	D	12.00 BSC		
Molded Package Width	E1	10.00 BSC		
Molded Package Length	D1	10.00 BSC		
Lead Thickness	c	0.09	–	0.20
Lead Width	b	0.17	0.22	0.27
Mold Draft Angle Top	α	11°	12°	13°
Mold Draft Angle Bottom	β	11°	12°	13°

Notes:

- Pin 1 visual index feature may vary, but must be located within the hatched area.
- Chamfers at corners are optional; size may vary.
- Dimensions D1 and E1 do not include mold flash or protrusions. Mold flash or protrusions shall not exceed 0.25 mm per side.
- Dimensioning and tolerancing per ASME Y14.5M.

BSC: Basic Dimension. Theoretically exact value shown without tolerances.

REF: Reference Dimension, usually without tolerance, for information purposes only.

Microchip Technology Drawing C04-085B

PIC18F6520/8520/6620/8620/6720/8720

64-Lead Plastic Thin Quad Flatpack (PT) 10x10x1 mm Body, 2.00 mm Footprint [TQFP]

Note: For the most current package drawings, please see the Microchip Packaging Specification located at <http://www.microchip.com/packaging>

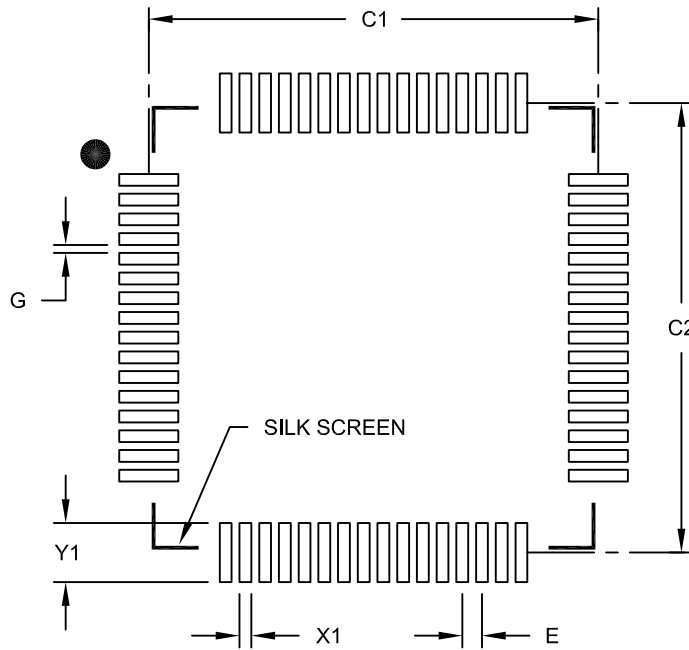

RECOMMENDED LAND PATTERN

		Units	MILLIMETERS		
		Dimension Limits	MIN	NOM	MAX
Contact Pitch	E		0.50 BSC		
Contact Pad Spacing	C1			11.40	
Contact Pad Spacing	C2			11.40	
Contact Pad Width (X64)	X1				0.30
Contact Pad Length (X64)	Y1				1.50
Distance Between Pads	G	0.20			

Notes:

1. Dimensioning and tolerancing per ASME Y14.5M

BSC: Basic Dimension. Theoretically exact value shown without tolerances.

Microchip Technology Drawing No. C04-2085B

PIC18F6520/8520/6620/8620/6720/8720

80-Lead Plastic Thin Quad Flatpack (PT) – 12x12x1 mm Body, 2.00 mm [TQFP]

Note: For the most current package drawings, please see the Microchip Packaging Specification located at <http://www.microchip.com/packageing>

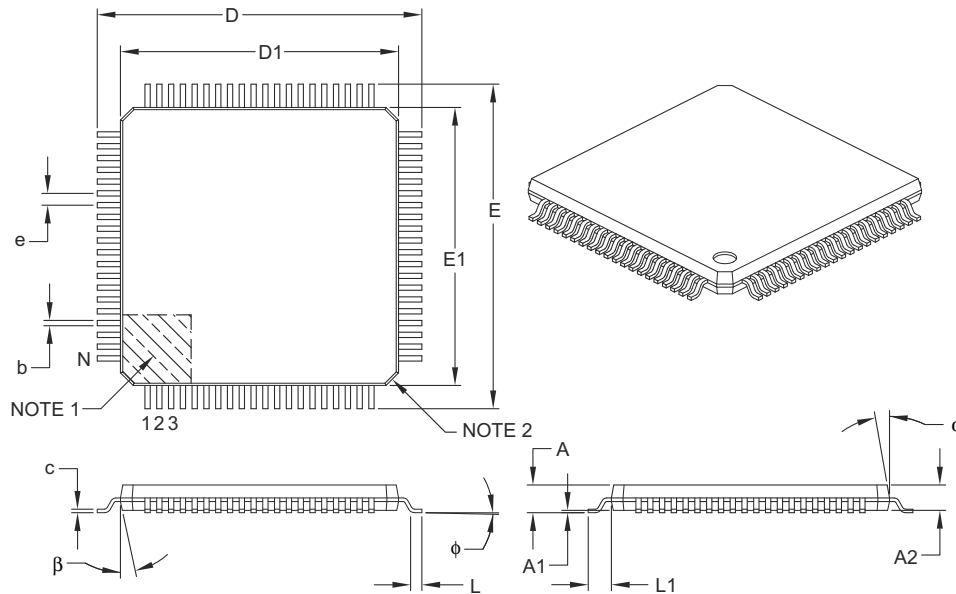

Dimension Limits	Units	MILLIMETERS		
		MIN	NOM	MAX
Number of Leads	N	80		
Lead Pitch	e	0.50 BSC		
Overall Height	A	–	–	1.20
Molded Package Thickness	A2	0.95	1.00	1.05
Standoff	A1	0.05	–	0.15
Foot Length	L	0.45	0.60	0.75
Footprint	L1	1.00 REF		
Foot Angle	ϕ	0°	3.5°	7°
Overall Width	E	14.00 BSC		
Overall Length	D	14.00 BSC		
Molded Package Width	E1	12.00 BSC		
Molded Package Length	D1	12.00 BSC		
Lead Thickness	c	0.09	–	0.20
Lead Width	b	0.17	0.22	0.27
Mold Draft Angle Top	α	11°	12°	13°
Mold Draft Angle Bottom	β	11°	12°	13°

Notes:

- Pin 1 visual index feature may vary, but must be located within the hatched area.
- Chamfers at corners are optional; size may vary.
- Dimensions D1 and E1 do not include mold flash or protrusions. Mold flash or protrusions shall not exceed 0.25 mm per side.
- Dimensioning and tolerancing per ASME Y14.5M.

BSC: Basic Dimension. Theoretically exact value shown without tolerances.

REF: Reference Dimension, usually without tolerance, for information purposes only.

Microchip Technology Drawing C04-092B

PIC18F6520/8520/6620/8620/6720/8720

80-Lead Plastic Thin Quad Flatpack (PT) -12x12x1mm Body, 2.00 mm Footprint [TQFP]

Note: For the most current package drawings, please see the Microchip Packaging Specification located at <http://www.microchip.com/packaging>

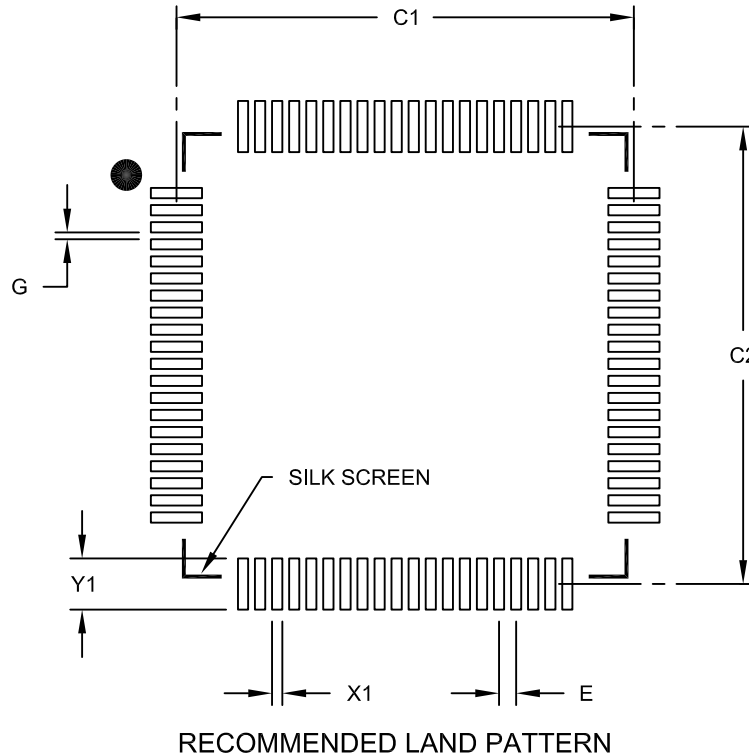

		MILLIMETERS		
Units		MIN	NOM	MAX
Dimension Limits				
Contact Pitch	E	0.50 BSC		
Contact Pad Spacing	C1		13.40	
Contact Pad Spacing	C2		13.40	
Contact Pad Width (X80)	X1			0.30
Contact Pad Length (X80)	Y1			1.50
Distance Between Pads	G	0.20		

Notes:

1. Dimensioning and tolerancing per ASME Y14.5M

BSC: Basic Dimension. Theoretically exact value shown without tolerances.

Microchip Technology Drawing No. C04-2092B

PIC18F6520/8520/6620/8620/6720/8720

NOTES:

PIC18F6520/8520/6620/8620/6720/8720

APPENDIX A: REVISION HISTORY

Revision A (January 2003)

Original data sheet for the PIC18FXX20 family which includes PIC18F6520, PIC18F6620, PIC18F6720, PIC18F8520, PIC18F8620 and PIC18F8720 devices.

This data sheet is based on the previous PIC18FXX20 Data Sheet (DS39580).

Revision B (January 2004)

This revision includes the DC and AC Characteristics Graphs and Tables. The Electrical Specifications in **Section 26.0 “Electrical Characteristics”** have been updated and there have been minor corrections to the data sheet text.

Revision C (November 2011)

This revision updated **Section 28.0 “Packaging Information”**.

APPENDIX B: DEVICE DIFFERENCES

The differences between the devices listed in this data sheet are shown in Table B-1.

TABLE B-1: DEVICE DIFFERENCES

Feature	PIC18F6520	PIC18F6620	PIC18F6720	PIC18F8520	PIC18F8620	PIC18F8720
On-Chip Program Memory (Kbytes)	32	64	128	32	64	128
Data Memory (bytes)	2048	3840	3840	2048	3840	3840
Boot Block (bytes)	2048	512	512	2048	512	512
Timer1 Low-Power Option	Yes	No	No	Yes	No	No
I/O Ports	Ports A, B, C, D, E, F, G	Ports A, B, C, D, E, F, G	Ports A, B, C, D, E, F, G	Ports A, B, C, D, E, F, G, H, J	Ports A, B, C, D, E, F, G, H, J	Ports A, B, C, D, E, F, G, H, J
A/D Channels	12	12	12	16	16	16
External Memory Interface	No	No	No	Yes	Yes	Yes
Maximum Operating Frequency (MHz)	40	25	25	40	25	25
Package Types	64-pin TQFP	64-pin TQFP	64-pin TQFP	80-pin TQFP	80-pin TQFP	80-pin TQFP

PIC18F6520/8520/6620/8620/6720/8720

APPENDIX C: CONVERSION CONSIDERATIONS

This appendix discusses the considerations for converting from previous versions of a device to the ones listed in this data sheet. Typically, these changes are due to the differences in the process technology used. An example of this type of conversion is from a PIC17C756 to a PIC18F8720.

Not Currently Available

APPENDIX D: MIGRATION FROM MID-RANGE TO ENHANCED DEVICES

A detailed discussion of the differences between the mid-range MCU devices (i.e., PIC16CXXX) and the enhanced devices (i.e., PIC18FXXX) is provided in AN716, *"Migrating Designs from PIC16C74A/74B to PIC18C442"*. The changes discussed, while device specific, are generally applicable to all mid-range to enhanced device migrations.

This Application Note is available as Literature Number DS00716.

APPENDIX E: MIGRATION FROM HIGH-END TO ENHANCED DEVICES

A detailed discussion of the migration pathway and differences between the high-end MCU devices (i.e., PIC17CXXX) and the enhanced devices (i.e., PIC18FXXX) is provided in AN726, "*PIC17CXXX to PIC18CXXX Migration*". This Application Note is available as Literature Number DS00726.

PIC18F6520/8520/6620/8620/6720/8720

NOTES:

PIC18F6520/8520/6620/8620/6720/8720

INDEX

A

A/D	213
A/D Converter Interrupt, Configuring	217
Acquisition Requirements	218
Acquisition Time	218
ADCON0 Register	213
ADCON1 Register	213
ADCON2 Register	213
ADRESH Register	213, 215
ADRESL Register	213, 215
Analog Port Pins	128
Analog Port Pins, Configuring	219
Associated Register Summary	221
Calculating Minimum Required Acquisition Time (Example)	218
CCP2 Trigger	220
Configuring the Module	217
Conversion Clock (Tad)	219
Conversion Requirements	339
Conversion Status (GO/DONE Bit)	215
Conversion Tad Cycles	220
Conversions	220
Converter Characteristics	338
Equations	218
Minimum Charging Time	218
Special Event Trigger (CCP)	152
Special Event Trigger (CCP2)	220
Tad vs. Device Operating Frequencies (Table)	219
Absolute Maximum Ratings	305
AC (Timing) Characteristics	318
Load Conditions for Device Timing Specifications	319
Parameter Symbolology	318
Temperature and Voltage Specifications	319
Timing Conditions	319
ACKSTAT Status Flag	187
ADCON0 Register	213
GO/DONE Bit	215
ADCON1 Register	213
ADCON2 Register	213
ADDLW	265
Addressable Universal Synchronous Asynchronous Receiver Transmitter (USART)	197
ADDWF	265
ADDWFC	266
ADRESH Register	213, 215
ADRESL Register	213, 215
Analog-to-Digital Converter. <i>See</i> A/D.	
ANDLW	266
ANDWF	267
Assembler	
MPASM Assembler	302

B

Baud Rate Generator	183
BC	267
BCF	268
BF Status Flag	187
Block Diagrams	
16-bit Byte Select Mode	75
16-bit Byte Write Mode	73
16-bit Word Write Mode	74
A/D	216
Analog Input Model	217

Baud Rate Generator	183
Capture Mode Operation	151
Comparator Analog Input Model	227
Comparator I/O Operating Modes (Diagram)	224
Comparator Output	226
Comparator Voltage Reference	230
Compare Mode Operation	152
Low-Voltage Detect (LVD)	234
Low-Voltage Detect (LVD) with External Input	234
MSSP (I ² C Master Mode)	181
MSSP (I ² C Mode)	166
MSSP (SPI Mode)	157
On-Chip Reset Circuit	29
PIC18F6X20 Architecture	9
PIC18F8X20 Architecture	10
PLL	23
PORT/LAT/TRIS Operation	103
PORTA	
RA3:RA0 and RA5 Pins	104
RA4/T0CKI Pin	104
RA6 Pin (as I/O)	104
PORTB	
RB2:RB0 Pins	107
RB3 Pin	107
RB7:RB4 Pins	106
PORTC (Peripheral Output Override)	109
PORTD and PORTE	
Parallel Slave Port	128
PORTD in I/O Port Mode	111
PORTD in System Bus Mode	112
PORTE in I/O Mode	115
PORTE in System Bus Mode	115
PORTF	
RF1/AN6/C2OUT and RF2/AN5/C1OUT Pins	117
RF6/RF3 and RF0 Pins	118
RF7 Pin	118
PORTG (Peripheral Output Override)	120
PORTH	
RH3:RH0 Pins in System Bus Mode	123
RH3:RH0 Pins in I/O Mode	122
RH7:RH4 Pins in I/O Mode	122
PORTJ	
RJ4:RJ0 Pins in System Bus Mode	126
RJ7:RJ6 Pins in System Bus Mode	126
PORTJ in I/O Mode	125
PWM Operation (Simplified)	154
Reads from Flash Program Memory	65
Single Comparator	225
Table Read Operation	61
Table Write Operation	62
Table Writes to Flash Program Memory	67
Timer0 in 16-bit Mode	132
Timer0 in 8-bit Mode	132
Timer1	136
Timer1 (16-bit R/W Mode)	136
Timer2	142
Timer3	144
Timer3 in 16-bit R/W Mode	144
Timer4	148
USART Receive	206
USART Transmit	204
Voltage Reference Output Buffer Example	231

PIC18F6520/8520/6620/8620/6720/8720

Watchdog Timer	251	Loading the SSPBUF (SSPSR) Register	160
BN	268	Reading a Flash Program Memory Word	65
BNC	269	Saving Status, WREG and BSR Registers in RAM ..	102
BNN	269	Writing to Flash Program Memory	68–69
BNOV	270	Code Protection	239
BNZ	270	COMF	276
BOR. <i>See</i> Brown-out Reset.		Comparator	223
BOV	273	Analog Input Connection Considerations	227
BRA	271	Associated Registers	228
BRG. <i>See</i> Baud Rate Generator.		Configuration	224
Brown-out Reset (BOR)	30	Effects of a Reset	227
BSF	271	Interrupts	226
BTFSC	272	Operation	225
BTFSS	272	Operation During Sleep	227
BTG	273	Outputs	225
BZ	274	Reference	225
C		External Signal	225
C Compilers		Internal Signal	225
MPLAB C18	302	Response Time	225
CALL	274	Comparator Specifications	315
Capture (CCP Module)	151	Comparator Voltage Reference	229
Associated Registers	153	Accuracy and Error	230
CCP Pin Configuration	151	Associated Registers	231
CCPR1H:CCPR1L Registers	151	Configuring	229
Software Interrupt	151	Connection Considerations	230
Timer1/Timer3 Mode Selection	151	Effects of a Reset	230
Capture/Compare/PWM (CCP)	149	Operation During Sleep	230
Capture Mode. <i>See</i> Capture.		Compare (CCP Module)	152
CCP Mode and Timer Resources	150	Associated Registers	153
CCPRxH Register	150	CCP Pin Configuration	152
CCPRxL Register	150	CCPR1 Register	152
Compare Mode. <i>See</i> Compare.		Software Interrupt	152
Interconnect Configurations	150	Special Event Trigger	138, 145, 152
Module Configuration	150	Timer1/Timer3 Mode Selection	152
PWM Mode. <i>See</i> PWM.		Compare (CCP2 Module)	
Capture/Compare/PWM Requirements (All CCP Modules) ...	327	Special Event Trigger	220
CLKO and I/O Timing Requirements	322, 323	Configuration Bits	239
Clocking Scheme/Instruction Cycle	44	Context Saving During Interrupts	102
CLRF	275	Control Registers	
CLRWDT	275	EECON1 and EECON2	62
Code Examples		TABLAT (Table Latch) Register	64
16 x 16 Signed Multiply Routine	86	TBLPTR (Table Pointer) Register	64
16 x 16 Unsigned Multiply Routine	86	Conversion Considerations	362
8 x 8 Signed Multiply Routine	85	CPFSEQ	276
8 x 8 Unsigned Multiply Routine	85	CPFSGT	277
Changing Between Capture Prescalers	151	CPFSLT	277
Data EEPROM Read	81	Customer Change Notification Service	375
Data EEPROM Refresh Routine	82	Customer Notification Service	375
Data EEPROM Write	81	Customer Support	375
Erasing a Flash Program Memory Row	66	D	
Fast Register Stack	44	Data EEPROM Memory	
How to Clear RAM (Bank 1) Using Indirect Addressing .	57	Associated Registers	83
Implementing a Real-Time Clock using a Timer1 Inter-		EEADR Register	79
rupt Service	139	EEADRH Register	79
Initializing PORTA	103	EECON1 Register	79
Initializing PORTB	106	EECON2 Register	79
Initializing PORTC	109	Operation During Code-Protect	82
Initializing PORTD	111	Protection Against Spurious Write	82
Initializing PORTE	114	Reading	81
Initializing PORTF	117	Using	82
Initializing PORTG	120	Write Verify	82
Initializing PORTH	122	Writing	81
Initializing PORTJ	125	Data Memory	47
		General Purpose Registers	47
		Map for PIC18FX520 Devices	48

PIC18F6520/8520/6620/8620/6720/8720

Map for PIC18FX620/X720 Devices	49	Operation	85
Special Function Registers	47	Performance Comparison	85
DAW	278	HS/PLL	23
DC and AC Characteristics		I	
Graphs and Tables	341	I/O Ports	103
DC Characteristics		I ² C Bus Data Requirements (Slave Mode)	334
PIC18FXX20 (Industrial and Extended), PIC18LFX20		I ² C Bus Start/Stop Bits Requirements (Slave Mode)	333
(Industrial)	313	I ² C Mode	
Power-Down and Supply Current	309	General Call Address Support	180
Supply Voltage	308	Master Mode	
DCFSNZ	279	Operation	182
DECF	278	Read/Write Bit Information (R/W Bit)	170, 171
DECFSZ	279	Serial Clock (RC3/SCK/SCL)	171
Development Support	301	ID Locations	239, 257
Device Differences	361	INCF	280
Direct Addressing	58	INCFSZ	281
Direct Addressing	56	In-Circuit Debugger	257
E		Resources (Table)	257
Electrical Characteristics	305	In-Circuit Serial Programming (ICSP)	239, 257
Errata	5	Indirect Addressing	58
Example SPI Mode Requirements (Master Mode, CKE = 0) .		INDF and FSR Registers	57
329		Operation	57
Example SPI Mode Requirements (Master Mode, CKE = 1) .		Indirect Addressing Operation	58
330		Indirect File Operand	47
Example SPI Mode Requirements (Slave Mode, CKE = 0) ...		INFSNZ	281
331		Instruction Cycle	44
Example SPI Slave Mode Requirements (CKE = 1)	332	Instruction Flow/Pipelining	45
Extended Microcontroller Mode	71	Instruction Format	261
External Clock Timing Requirements	320	Instruction Set	259
External Memory Interface	71	ADDLW	265
16-bit Byte Select Mode	75	ADDWF	265
16-bit Byte Write Mode	73	ADDWFC	266
16-bit Mode	73	ANDLW	266
16-bit Mode Timing	76	ANDWF	267
16-bit Word Write Mode	74	BC	267
PIC18F8X20 External Bus - I/O Port Functions	72	BCF	268
Program Memory Modes and External Memory Interface		BN	268
.....	71	BNC	269
		BNN	269
		BNOV	270
		BNZ	270
		BOV	273
		BRA	271
		BSF	271
		BTFSC	272
		BTFSS	272
		BTG	273
		BZ	274
		CALL	274
		CLRf	275
		CLRWDt	275
		COMF	276
		CPFSEQ	276
		CPFSGT	277
		CPFSLT	277
		DAW	278
		DCFSNZ	279
		DECF	278
		DECFSZ	279
		GOTO	280
		INCF	280
		INCFSZ	281
		INFSNZ	281
		IORLW	282
		IORWF	282
F			
Firmware Instructions	259		
Flash Program Memory	61		
Associated Registers	69		
Control Registers	62		
Erase Sequence	66		
Erasing	66		
Operation During Code-Protect	69		
Reading	65		
Table Pointer			
Boundaries Based on Operation	64		
Table Pointer Boundaries	64		
Table Reads and Table Writes	61		
Write Sequence	67		
Writing To	67		
Protection Against Spurious Writes	69		
Unexpected Termination	69		
Write Verify	69		
G			
General Call Address Support	180		
GOTO	280		
H			
Hardware Multiplier	85		
Introduction	85		

PIC18F6520/8520/6620/8620/6720/8720

LFSR	283	Easy Migration	7
MOVF	283	Expanded Memory	7
MOVFF	284	External Memory Interface	7
MOVLB	284	Other Special Features	7
MOVLW	285		
MOVWF	285	L	
MULLW	286	LFSR	283
MULWF	286	Low-Voltage Detect	233
NEGF	287	Characteristics	316
NOP	287	Converter Characteristics	316
POP	288	Effects of a Reset	237
PUSH	288	Operation	236
RCALL	289	Current Consumption	237
RESET	289	During Sleep	237
RETFIE	290	Reference Voltage Set Point	237
RETLW	290	Typical Application	233
RETURN	291	Low-Voltage ICSP Programming	257
RLCF	291	LVD. <i>See</i> Low-Voltage Detect.	233
RLNCF	292		
RRCF	292	M	
RRNCF	293	Master SSP (MSSP) Module	
SETF	293	Overview	157
SLEEP	294	Master SSP I ² C Bus Data Requirements	336
SUBFWB	294	Master SSP I ² C Bus Start/Stop Bits Requirements	335
SUBLW	295	Master Synchronous Serial Port (MSSP). <i>See</i> MSSP.	
SUBWF	295	Master Synchronous Serial Port. <i>See</i> MSSP	
SUBWFB	296	Memory Organization	
SWAPF	296	Data Memory	47
TBLRD	297	Memory Programming Requirements	317
TBLWT	298	Microchip Internet Web Site	375
TSTFSZ	299	Microcontroller Mode	71
XORLW	299	Microprocessor Mode	71
XORWF	300	Microprocessor with Boot Block Mode	71
Summary Table	262	Migration from High-End to Enhanced Devices	363
INT Interrupt (RB0/INT). <i>See</i> Interrupt Sources		Migration from Mid-Range to Enhanced Devices	362
INTCON Registers	89	MOVF	283
Inter-Integrated Circuit. <i>See</i> I ² C		MOVFF	284
Internet Address	375	MOVLB	284
Interrupt Sources	239	MOVLW	285
A/D Conversion Complete	217	MOVWF	285
Capture Complete (CCP)	151	MPLAB ASM30 Assembler, Linker, Librarian	302
Compare Complete (CCP)	152	MPLAB Integrated Development Environment Software	301
INT0	102	MPLAB PM3 Device Programmer	304
Interrupt-on-Change (RB7:RB4)	106	MPLAB REAL ICE In-Circuit Emulator System	303
PORTB, Interrupt-on-Change	102	MPLINK Object Linker/MPLIB Object Librarian	302
RB0/INT Pin, External	102	MSSP	157
TMR0	102	ACK Pulse	170, 171
TMR0 Overflow	133	Clock Stretching	176
TMR1 Overflow	135, 138	10-bit Slave Receive Mode (SEN = 1)	176
TMR2 to PR2 Match	142	10-bit Slave Transmit Mode	176
TMR2 to PR2 Match (PWM)	141, 154	7-bit Slave Receive Mode (SEN = 1)	176
TMR3 Overflow	143, 145	7-bit Slave Transmit Mode	176
TMR4 to PR4 Match	148	Clock Synchronization and the CKP bit	177
TMR4 to PR4 Match (PWM)	147	Control Registers (general)	157
Interrupts	87	Enabling SPI I/O	161
Control Registers	89	I ² C Mode	166
Enable Registers	95	Acknowledge Sequence Timing	190
Flag Registers	92	Baud Rate Generator	183
Logic	88	Bus Collision	
Priority Registers	98	During a Repeated Start Condition	194
Reset Control Registers	101	Bus Collision During a Start Condition	192
IORLW	282	Bus Collision During a Stop Condition	195
IORWF	282	Clock Arbitration	184
IPR Registers	98	Effect of a Reset	191
K		I ² C Clock Rate w/BRG	183
Key Features		Master Mode	181
		Reception	187

PIC18F6520/8520/6620/8620/6720/8720

Repeated Start Timing	186	RE1/ $\overline{\text{WR}}$ /AN6 Pin	128
Master Mode Start Condition	185	RE2/ $\overline{\text{CS}}$ /AN7 Pin	128
Master Mode Transmission	187	Read Waveforms	130
Multi-Master Communication, Bus Collision and Arbitration	191	Select (PSPMODE Bit)	111, 128
Multi-Master Mode	191	Write Waveforms	129
Registers	166	Parallel Slave Port Requirements (PIC18F8X20)	328
Sleep Operation	191	PIE Registers	95
Stop Condition Timing	190	Pin Functions	
I ² C Mode. See I ² C		AVDD	20
Module Operation	170	AVss	20
Operation	160	MCLR/VPP	11
Slave Mode	170	OSC1/CLKI	11
Addressing	170	OSC2/CLKO/RA6	11
Reception	171	RA0/AN0	12
Transmission	171	RA1/AN1	12
SPI		RA2/AN2/VREF-	12
Master Mode	162	RA3/AN3/VREF+	12
SPI Clock	162	RA4/T0CKI	12
SPI Master Mode	162	RA5/AN4/LVDIN	12
SPI Mode	157	RA6	12
SPI Mode. See SPI		RB0/INT0	13
SPI Slave Mode	163	RB1/INT1	13
Select Synchronization	163	RB2/INT2	13
SSPBUF Register	162	RB3/INT3/CCP2	13
SSPSR Register	162	RB4/KBI0	13
Typical Connection	161	RB5/KBI1/PGM	13
MSSP Module		RB6/KBI2/PGC	13
SPI Master./Slave Connection	161	RB7/KBI3/PGD	13
MULLW	286	RC0/T1OSO/T13CKI	14
MULWF	286	RC1/T1OSI/CCP2	14
		RC2/CCP1	14
N		RC3/SCK/SCL	14
NEGF	287	RC4/SDI/SDA	14
NOP	287	RC5/SDO	14
		RC6/TX1/CK1	14
O		RC7/RX1/DT1	14
Opcode Field Descriptions	260	RD0/PSP0/AD0	15
OPTION_REG Register		RD1/PSP1/AD1	15
PSA Bit	133	RD2/PSP2/AD2	15
T0CS Bit	133	RD3/PSP3/AD3	15
T0PS2:T0PS0 Bits	133	RD4/PSP4/AD4	15
T0SE Bit	133	RD5/PSP5/AD5	15
Oscillator Configuration	21	RD6/PSP6/AD6	15
EC	21	RD7/PSP7/AD7	15
ECIO	21	RE0/ $\overline{\text{RD}}$ /AD8	16
HS	21	RE1/ $\overline{\text{WR}}$ /AD9	16
HS + PLL	21	RE2/ $\overline{\text{CS}}$ /AD10	16
LP	21	RE3/AD11	16
RC	21	RE4/AD12	16
RCIO	21	RE5/AD13	16
XT	21	RE6/AD14	16
Oscillator Selection	239	RE7/CCP2/AD15	16
Oscillator Switching Feature	24	RF0/AN5	17
Oscillator Transitions	26	RF1/AN6/C2OUT	17
System Clock Switch Bit	25	RF2/AN7/C1OUT	17
Oscillator, Timer1	135, 137, 145	RF3/AN8	17
Oscillator, Timer3	143	RF4/AN9	17
Oscillator, WDT	250	RF5/AN10/CVREF	17
		RF6/AN11	17
P		RF7/ $\overline{\text{SS}}$	17
Packaging Information	355	RG0/CCP3	18
Details	356	RG1/TX2/CK2	18
Marking	355	RG2/RX2/DT2	18
Parallel Slave Port (PSP)	111, 128	RG3/CCP4	18
Associated Registers	130	RG4/CCP5	18
RE0/ $\overline{\text{RD}}$ /AN5 Pin	128	RH0/A16	19

PIC18F6520/8520/6620/8620/6720/8720

RH1/A17	19	PORTF Register	117
RH2/A18	19	TRISF Register	117
RH3/A19	19	PORTG	
RH4/AN12	19	Associated Registers	121
RH5/AN13	19	Functions	121
RH6/AN14	19	LATG Register	120
RH7/AN15	19	PORTG Register	120
RJ0/ALE	20	TRISG Register	120, 197
RJ1/OE	20	PORTH	
RJ2/WRL	20	Associated Registers	124
RJ3/WRH	20	Functions	124
RJ4/BA0	20	LATH Register	122
RJ5/CE	20	PORTH Register	122
RJ6/LB	20	TRISH Register	122
RJ7/UB	20	PORTJ	
VDD	20	Associated Registers	127
Vss	20	Functions	127
PIR Registers	92	LATJ Register	125
PLL Clock Timing Specifications	321	PORTJ Register	125
PLL Lock Time-out	30	TRISJ Register	125
Pointer, FSR	57	Postscaler, WDT	
POP	288	Assignment (PSA Bit)	133
POR. <i>See</i> Power-on Reset.		Rate Select (T0PS2:T0PS0 Bits)	133
PORTA		Switching Between Timer0 and WDT	133
Associated Registers	105	Power-down Mode. <i>See</i> Sleep.	
Functions	105	Power-on Reset (POR)	30
LATA Register	103	Oscillator Start-up Timer (OST)	30
PORTA Register	103	Power-up Timer (PWRT)	30
TRISA Register	103	Time-out Sequence	30
PORTB		Prescaler, Capture	151
Associated Registers	108	Prescaler, Timer0	133
Functions	108	Assignment (PSA Bit)	133
LATB Register	106	Rate Select (T0PS2:T0PS0 Bits)	133
PORTB Register	106	Switching Between Timer0 and WDT	133
RB0/INT Pin, External	102	Prescaler, Timer2	154
TRISB Register	106	Product Identification System	377
PORTC		Program Counter	
Associated Registers	110	PCL, PCLATH and PCLATU Registers	44
Functions	110	Program Memory	39
LATC Register	109	Access for PIC18F8X20 Program Memory Modes	40
PORTC Register	109	Instructions	45
RC3/SCK/SCL Pin	171	Interrupt Vector	39
TRISC Register	109, 197	Map and Stack for PIC18FXX20	40
PORTD	128	Maps for PIC18F8X20 Program Memory Modes	41
Associated Registers	113	PIC18F8X20 Modes	39
Functions	113	Reset Vector	39
LATD Register	111	Program Memory Write Timing Requirements	324
Parallel Slave Port (PSP) Function	111	Program Verification and Code Protection	253
PORTD Register	111	Associated Registers	253
TRISD Register	111	Configuration Register Protection	257
PORTE		Data EEPROM Code Protection	257
Analog Port Pins	128	Memory Code Protection	255
Associated Registers	116	Programming, Device Instructions	259
Functions	116	PSP. <i>See</i> Parallel Slave Port.	
LATE Register	114	Pulse Width Modulation. <i>See</i> PWM (CCP Module).	
PORTE Register	114	PUSH	288
PSP Mode Select (PSPMODE Bit)	111, 128	PWM (CCP Module)	154
RE0/RD/AN5 Pin	128	Associated Registers	155
RE1/WR/AN6 Pin	128	CCPR1H:CCPR1L Registers	154
RE2/CS/AN7 Pin	128	Duty Cycle	154
TRISE Register	114	Example Frequencies/Resolutions	155
PORTF		Period	154
Associated Registers	119	Setup for PWM Operation	155
Functions	119	TMR2 to PR2 Match	141, 154
LATF Register	117	TMR4 to PR4 Match	147

PIC18F6520/8520/6620/8620/6720/8720

Q

Q Clock 154

R

RAM. *See* Data Memory

RC Oscillator 22

RCALL 289

RCON Registers 101

RCSTA Register

 SPEN Bit 197

Reader Response 376

Register File 47

Registers

 ADCON0 (A/D Control 0) 213

 ADCON1 (A/D Control 1) 214

 ADCON2 (A/D Control 2) 215

 CCPxCON (Capture/Compare/PWM Control) 149

 CMCON (Comparator Control) 223

 CONFIG1H (Configuration 1 High) 240

 CONFIG2H (Configuration 2 High) 241

 CONFIG2L (Configuration 2 Low) 241

 CONFIG3H (Configuration 3 High) 242

 CONFIG3L (Configuration 3 Low) 242

 CONFIG3L (Configuration Byte) 41

 CONFIG4L (Configuration 4 Low) 243

 CONFIG5H (Configuration 5 High) 245

 CONFIG5L (Configuration 5 Low) 244

 CONFIG6H (Configuration 6 High) 247

 CONFIG6L (Configuration 6 Low) 246

 CONFIG7H (Configuration 7 High) 249

 CONFIG7L (Configuration 7 Low) 248

 CVRCON (Comparator Voltage Reference Control) 229

 Device ID 1 249

 Device ID 2 249

 EECON1 (Data EEPROM Control 1) 63, 80

 INTCON (Interrupt Control) 89

 INTCON2 (Interrupt Control 2) 90

 INTCON3 (Interrupt Control 3) 91

 IPR1 (Peripheral Interrupt Priority 1) 98

 IPR2 (Peripheral Interrupt Priority 2) 99

 IPR3 (Peripheral Interrupt Priority 3) 100

 LVDCON (Low-Voltage Detect Control) 235

 MEMCON (Memory Control) 71

 OSCCON 25

 PIE1 (Peripheral Interrupt Enable 1) 95

 PIE2 (Peripheral Interrupt Enable 2) 96

 PIE3 (Peripheral Interrupt Enable 3) 97

 PIR1 (Peripheral Interrupt Request 1) 92

 PIR2 (Peripheral Interrupt Request 2) 93

 PIR3 (Peripheral Interrupt Request 3) 94

 PSPCON (Parallel Slave Port Control) Register 129

 RCON 31

 RCON (Reset Control) 60, 101

 RCSTAx (Receive Status and Control) 199

 SSPCON2 (MSSP Control 2, I²C Mode) 169

 SSPSTAT (MSSP Status, I²C Mode) 167

 SSPSTAT (MSSP Status, SPI Mode) 158

 Statis 59

 STKPTR (Stack Pointer) 43

 Summary 52–55

 T1CON (Timer 1 Control) 135

 T3CON (Timer3 Control) 143

 TXSTAx (Transmit Status and Control) 198

 WDTCON (Watchdog Timer Control) 250

RESET 289

Reset 29, 239

Brown-out Reset (BOR) 239

 MCLR Reset 29

 MCLR Reset during Sleep 29

 Oscillator Start-up Timer (OST) 239

 Power-on Reset (POR) 29, 239

 Power-up Timer (PWRT) 239

 Programmable Brown-out Reset (PBOR) 29

 Reset Instruction 29

 Stack Full Reset 29

 Stack Underflow Reset 29

 Watchdog Timer (WDT) Reset 29

Reset, Watchdog Timer, Oscillator Start-up Timer, Power-up

 Timer and Brown-out Reset Requirements 325

RETFIE 290

RETLW 290

RETURN 291

Return Address Stack

 and Associated Registers 43

Revision History 361

RLCF 291

RLNCF 292

RRCF 292

RRNCF 293

S

SCI. *See* USART

SCK 157

SDI 157

SDO 157

Serial Clock, SCK 157

Serial Communication Interface. *See* USART.

Serial Data In, SDI 157

Serial Data Out, SDO 157

Serial Peripheral Interface. *See* SPI

SETF 293

Slave Select, \overline{SS} 157

SLEEP 294

Sleep 239, 252

Software Simulator (MPLAB SIM) 303

Special Event Trigger. *See* Compare

Special Features of the CPU 239

 Configuration Registers 240–249

Special Function Registers 47

 Map 50

SPI

 Serial Clock 157

 Serial Data In 157

 Serial Data Out 157

 Slave Select 157

 SPI Mode 157

SPI Master/Slave Connection 161

SPI Module

 Associated Registers 165

 Bus Mode Compatibility 165

 Effects of a Reset 165

 Master/Slave Connection 161

 Slave Mode 163

 Sleep Operation 165

\overline{SS} 157

SSP

 TMR2 Output for Clock Shift 141, 142

 TMR4 Output for Clock Shift 148

SSPOV Status Flag 187

SSPSTAT Register

 R/W Bit 170, 171

Status Bits

 Significance and Initialization Condition for RCON Reg-

PIC18F6520/8520/6620/8620/6720/8720

Register	31	Bus Collision During a Repeated Start Condition (Case 2)	194
SUBFWB	294	Bus Collision During a Stop Condition (Case 1)	195
SUBLW	295	Bus Collision During a Stop Condition (Case 2)	195
SUBWF	295	Bus Collision During Start Condition (SCL = 0)	193
SUBWFB	296	Bus Collision During Start Condition (SDA only)	192
SWAPF	296	Bus Collision for Transmit and Acknowledge	191
T		Capture/Compare/PWM (All CCP Modules)	326
Table Pointer Operations (table)	64	CLKO and I/O	321
TBLRD	297	Clock Synchronization	177
TBLWT	298	Clock/Instruction Cycle	44
Time-out in Various Situations	31	Example SPI Master Mode (CKE = 0)	328
Timer0	131	Example SPI Master Mode (CKE = 1)	329
16-bit Mode Timer Reads and Writes	133	Example SPI Slave Mode (CKE = 0)	330
Associated Registers	133	Example SPI Slave Mode (CKE = 1)	331
Clock Source Edge Select (T0SE Bit)	133	External Clock (All Modes except PLL)	320
Clock Source Select (T0CS Bit)	133	External Memory Bus for Sleep (Microprocessor Mode)	77
Operation	133	External Memory Bus for TBLRD (Extended Microcontroller Mode)	76
Overflow Interrupt	133	External Memory Bus for TBLRD (Microprocessor Mode)	76
Prescaler. <i>See</i> Prescaler, Timer0		I ² C Bus Data	333
Timer0 and Timer1 External Clock Requirements	326	I ² C Bus Start/Stop Bits	332
Timer1	135	I ² C Master Mode (7 or 10-bit Transmission)	188
16-bit Read/Write Mode	138	I ² C Master Mode (7-bit Reception)	189
Associated Registers	139	I ² C Master Mode First Start Bit Timing	185
Operation	136	I ² C Slave Mode (10-bit Reception, SEN = 0)	174
Oscillator	135, 137	I ² C Slave Mode (10-bit Reception, SEN = 1)	179
Overflow Interrupt	135, 138	I ² C Slave Mode (10-bit Transmission)	175
Special Event Trigger (CCP)	138, 152	I ² C Slave Mode (7-bit Reception, SEN = 0)	172
TMR1H Register	135	I ² C Slave Mode (7-bit Reception, SEN = 1)	178
TMR1L Register	135	I ² C Slave Mode (7-bit Transmission)	173
Use as a Real-Time Clock	138	Low-Voltage Detect	236
Timer2	141	Master SSP I ² C Bus Data	335
Associated Registers	142	Master SSP I ² C Bus Start/Stop Bits	335
Operation	141	Parallel Slave Port (PIC18F8X20)	327
Postscaler. <i>See</i> Postscaler, Timer2		Program Memory Read	322
PR2 Register	141, 154	Program Memory Write	323
Prescaler. <i>See</i> Prescaler, Timer2		PWM Output	154
SSP Clock Shift	141, 142	Repeat Start Condition	186
TMR2 Register	141	Reset, Watchdog Timer (WDT), Oscillator Start-up Timer (OST) and Power-up Timer (PWRT)	324
TMR2 to PR2 Match Interrupt	141, 142, 154	Slave Mode General Call Address Sequence (7 or 10-bit Address Mode)	180
Timer3	143	Slave Synchronization	163
Associated Registers	145	Slow Rise Time (MCLR Tied to VDD via 1 kOhm Resistor)	38
Operation	144	SPI Mode (Master Mode)	162
Oscillator	143, 145	SPI Mode (Slave Mode with CKE = 0)	164
Overflow Interrupt	143, 145	SPI Mode (Slave Mode with CKE = 1)	164
Special Event Trigger (CCP)	145	Stop Condition Receive or Transmit Mode	190
TMR3H Register	143	Synchronous Reception (Master Mode, SREN)	210
TMR3L Register	143	Synchronous Transmission	209
Timer4	147	Synchronous Transmission (Through TXEN)	209
Associated Registers	148	Time-out Sequence on POR w/PLL Enabled (MCLR Tied to VDD via 1 kOhm Resistor)	38
Operation	147	Time-out Sequence on Power-up (MCLR Not Tied to VDD)	
Postscaler. <i>See</i> Postscaler, Timer4		Case 1	37
PR4 Register	147	Case 2	37
Prescaler. <i>See</i> Prescaler, Timer4		Time-out Sequence on Power-up (MCLR Tied to VDD via 1 kOhm Resistor)	37
SSP Clock Shift	148	Timer0 and Timer1 External Clock	325
TMR4 Register	147	Timing for Transition Between Timer1 and OSC1 (HS	
TMR4 to PR4 Match Interrupt	147, 148		
Timing Diagrams			
A/D Conversion	338		
Acknowledge Sequence	190		
Baud Rate Generator with Clock Arbitration	184		
BRG Reset Due to SDA Arbitration During Start Condition	193		
Brown-out Reset (BOR)	325		
Bus Collision During a Repeated Start Condition (Case 1)	194		

PIC18F6520/8520/6620/8620/6720/8720

with PLL)	27	Time-out Period	250
Transition Between Timer1 and OSC1 (HS, XT, LP) .	26	WCOL	185
Transition Between Timer1 and OSC1 (RC, EC)	27	WCOL Status Flag	185, 186, 187, 190
Transition from OSC1 to Timer1 Oscillator	26	WDT Postscaler	250
USART Asynchronous Reception	207	WWW Address	375
USART Asynchronous Transmission	205	WWW, On-Line Support	5
USART Asynchronous Transmission (Back to Back)	205	X	
USART Synchronous Receive (Master/Slave)	337	XORLW	299
USART Synchronous Transmission (Master/Slave) .	337	XORWF	300
Wake-up from Sleep via Interrupt	253		
TRISE Register			
PSPMODE Bit	111, 128		
TSTFSZ	299		
Two-Word Instructions			
Example Cases	46		
TXSTA Register			
BRGH Bit	200		
U			
Universal Synchronous Asynchronous Receiver Transmitter.			
See USART			
USART			
Asynchronous Mode	204		
Associated Registers, Receive	207		
Associated Registers, Transmit	205		
Receiver	206		
Setting up 9-bit Mode with Address Detect	206		
Transmitter	204		
Baud Rate Generator (BRG)	200		
Associated Registers	200		
Baud Rate Error, Calculating	200		
Baud Rate Formula	200		
Baud Rates for Asynchronous Mode (BRGH = 0) .	202		
Baud Rates for Asynchronous Mode (BRGH = 1) .	203		
Baud Rates for Synchronous Mode	201		
High Baud Rate Select (BRGH Bit)	200		
Sampling	200		
Serial Port Enable (SPEN Bit)	197		
Synchronous Master Mode	208		
Associated Registers, Reception	210		
Associated Registers, Transmit	208		
Reception	210		
Transmission	208		
Synchronous Slave Mode	211		
Associated Registers, Receive	212		
Associated Registers, Transmit	211		
Reception	212		
Transmission	211		
USART Synchronous Receive Requirements	337		
USART Synchronous Transmission Requirements	337		
V			
Voltage Reference Specifications	315		
W			
Wake-up from Sleep	239, 252		
Using Interrupts	252		
Watchdog Timer (WDT)	239, 250		
Associated Registers	251		
Control Register	250		
Postscaler	251		
Programming Considerations	250		
RC Oscillator	250		

PIC18F6520/8520/6620/8620/6720/8720

THE MICROCHIP WEB SITE

Microchip provides online support via our WWW site at www.microchip.com. This web site is used as a means to make files and information easily available to customers. Accessible by using your favorite Internet browser, the web site contains the following information:

- **Product Support** – Data sheets and errata, application notes and sample programs, design resources, user's guides and hardware support documents, latest software releases and archived software
- **General Technical Support** – Frequently Asked Questions (FAQ), technical support requests, online discussion groups, Microchip consultant program member listing
- **Business of Microchip** – Product selector and ordering guides, latest Microchip press releases, listing of seminars and events, listings of Microchip sales offices, distributors and factory representatives

CUSTOMER CHANGE NOTIFICATION SERVICE

Microchip's customer notification service helps keep customers current on Microchip products. Subscribers will receive e-mail notification whenever there are changes, updates, revisions or errata related to a specified product family or development tool of interest.

To register, access the Microchip web site at www.microchip.com. Under "Support", click on "Customer Change Notification" and follow the registration instructions.

CUSTOMER SUPPORT

Users of Microchip products can receive assistance through several channels:

- Distributor or Representative
- Local Sales Office
- Field Application Engineer (FAE)
- Technical Support

Customers should contact their distributor, representative or field application engineer (FAE) for support. Local sales offices are also available to help customers. A listing of sales offices and locations is included in the back of this document.

Technical support is available through the web site at: <http://microchip.com/support>

PIC18F6520/8520/6620/8620/6720/8720

READER RESPONSE

It is our intention to provide you with the best documentation possible to ensure successful use of your Microchip product. If you wish to provide your comments on organization, clarity, subject matter, and ways in which our documentation can better serve you, please FAX your comments to the Technical Publications Manager at (480) 792-4150.

Please list the following information, and use this outline to provide us with your comments about this document.

TO: Technical Publications Manager Total Pages Sent _____

RE: Reader Response

From: Name _____

Company _____

Address _____

City / State / ZIP / Country _____

Telephone: (_____) _____ - _____ FAX: (_____) _____ - _____

Application (optional):

Would you like a reply? Y N

Device: PIC18F6520/8520/6620/8620/6720/8720

Literature Number: DS39609C

Questions:

1. What are the best features of this document?

2. How does this document meet your hardware and software development needs?

3. Do you find the organization of this document easy to follow? If not, why?

4. What additions to the document do you think would enhance the structure and subject?

5. What deletions from the document could be made without affecting the overall usefulness?

6. Is there any incorrect or misleading information (what and where)?

7. How would you improve this document?

PIC18F6520/8520/6620/8620/6720/8720

PIC18F6520/8520/6620/8620/6720/8720 PRODUCT IDENTIFICATION SYSTEM

To order or obtain information, e.g., on pricing or delivery, refer to the factory or the listed sales office.

<u>PART NO.</u>	-	<u>X</u>	<u>/XX</u>	<u>XXX</u>
Device		Temperature Range	Package	Pattern
Device		PIC18F6520/8520/6620/8620/6720/8720 ⁽¹⁾ ; PIC18F6520/8520/6620/8620/6720/8720T ⁽²⁾ ; VDD range 4.2V to 5.5V PIC18LF6520/8520/6620/8620/6720/8720 ⁽¹⁾ ; PIC18LF6520/8520/6620/8620/6720/8720T ⁽²⁾ ; VDD range 2.0V to 5.5V		
Temperature Range	I	= -40°C to +85°C (Industrial)		
	E	= -40°C to +125°C (Extended)		
Package	PT	= TQFP (Thin Quad Flatpack)		
Pattern		QTP, SQTP, Code or Special Requirements (blank otherwise)		

Examples:

- a) PIC18LF6620-I/PT 301 = Industrial temp., TQFP package, Extended VDD limits, QTP pattern #301.
- b) PIC18F8720-I/PT = Industrial temp., TQFP package, normal VDD limits.
- c) PIC18F8620-E/PT = Extended temp., TQFP package, standard VDD limits.

Note 1: F = Standard Voltage Range
 LF = Extended Voltage Range

2: T = in tape and reel

PIC18F6520/8520/6620/8620/6720/8720

NOTES:

Note the following details of the code protection feature on Microchip devices:

- Microchip products meet the specification contained in their particular Microchip Data Sheet.
- Microchip believes that its family of products is one of the most secure families of its kind on the market today, when used in the intended manner and under normal conditions.
- There are dishonest and possibly illegal methods used to breach the code protection feature. All of these methods, to our knowledge, require using the Microchip products in a manner outside the operating specifications contained in Microchip's Data Sheets. Most likely, the person doing so is engaged in theft of intellectual property.
- Microchip is willing to work with the customer who is concerned about the integrity of their code.
- Neither Microchip nor any other semiconductor manufacturer can guarantee the security of their code. Code protection does not mean that we are guaranteeing the product as "unbreakable."

Code protection is constantly evolving. We at Microchip are committed to continuously improving the code protection features of our products. Attempts to break Microchip's code protection feature may be a violation of the Digital Millennium Copyright Act. If such acts allow unauthorized access to your software or other copyrighted work, you may have a right to sue for relief under that Act.

Information contained in this publication regarding device applications and the like is provided only for your convenience and may be superseded by updates. It is your responsibility to ensure that your application meets with your specifications. MICROCHIP MAKES NO REPRESENTATIONS OR WARRANTIES OF ANY KIND WHETHER EXPRESS OR IMPLIED, WRITTEN OR ORAL, STATUTORY OR OTHERWISE, RELATED TO THE INFORMATION, INCLUDING BUT NOT LIMITED TO ITS CONDITION, QUALITY, PERFORMANCE, MERCHANTABILITY OR FITNESS FOR PURPOSE. Microchip disclaims all liability arising from this information and its use. Use of Microchip devices in life support and/or safety applications is entirely at the buyer's risk, and the buyer agrees to defend, indemnify and hold harmless Microchip from any and all damages, claims, suits, or expenses resulting from such use. No licenses are conveyed, implicitly or otherwise, under any Microchip intellectual property rights.

Trademarks

The Microchip name and logo, the Microchip logo, dsPIC, FlashFlex, KEELOQ, KEELOQ logo, MPLAB, PIC, PICmicro, PICSTART, PIC³² logo, rPIC, SST, SST Logo, SuperFlash and UNI/O are registered trademarks of Microchip Technology Incorporated in the U.S.A. and other countries.

FilterLab, Hampshire, HI-TECH C, Linear Active Thermistor, MTP, SEEVAL and The Embedded Control Solutions Company are registered trademarks of Microchip Technology Incorporated in the U.S.A.

Silicon Storage Technology is a registered trademark of Microchip Technology Inc. in other countries.

Analog-for-the-Digital Age, Application Maestro, BodyCom, chipKIT, chipKIT logo, CodeGuard, dsPICDEM, dsPICDEM.net, dsPICworks, dsSPEAK, ECAN, ECONOMONITOR, FanSense, HI-TIDE, In-Circuit Serial Programming, ICSP, Mindi, MiWi, MPASM, MPF, MPLAB Certified logo, MPLIB, MPLINK, mTouch, Omniclient Code Generation, PICC, PICC-18, PICDEM, PICDEM.net, PICkit, PICtail, REAL ICE, rLAB, Select Mode, SQI, Serial Quad I/O, Total Endurance, TSHARC, UniWinDriver, WiperLock, ZENA and Z-Scale are trademarks of Microchip Technology Incorporated in the U.S.A. and other countries.

SQTP is a service mark of Microchip Technology Incorporated in the U.S.A.

GestIC and ULPP are registered trademarks of Microchip Technology Germany II GmbH & Co. & KG, a subsidiary of Microchip Technology Inc., in other countries.

All other trademarks mentioned herein are property of their respective companies.

© 2003-2013, Microchip Technology Incorporated, Printed in the U.S.A., All Rights Reserved.

 Printed on recycled paper.

ISBN: 9781620769423

Microchip received ISO/TS-16949:2009 certification for its worldwide headquarters, design and wafer fabrication facilities in Chandler and Tempe, Arizona; Gresham, Oregon and design centers in California and India. The Company's quality system processes and procedures are for its PIC[®] MCUs and dsPIC[®] DSCs, KEELOQ[®] code hopping devices, Serial EEPROMs, microperipherals, nonvolatile memory and analog products. In addition, Microchip's quality system for the design and manufacture of development systems is ISO 9001:2000 certified.

QUALITY MANAGEMENT SYSTEM
CERTIFIED BY DNV
== ISO/TS 16949 ==



MICROCHIP

Worldwide Sales and Service

AMERICAS

Corporate Office
2355 West Chandler Blvd.
Chandler, AZ 85224-6199
Tel: 480-792-7200
Fax: 480-792-7277
Technical Support:
<http://www.microchip.com/support>
Web Address:
www.microchip.com

Atlanta
Duluth, GA
Tel: 678-957-9614
Fax: 678-957-1455

Boston
Westborough, MA
Tel: 774-760-0087
Fax: 774-760-0088

Chicago
Itasca, IL
Tel: 630-285-0071
Fax: 630-285-0075

Cleveland
Independence, OH
Tel: 216-447-0464
Fax: 216-447-0643

Dallas
Addison, TX
Tel: 972-818-7423
Fax: 972-818-2924

Detroit
Farmington Hills, MI
Tel: 248-538-2250
Fax: 248-538-2260

Indianapolis
Noblesville, IN
Tel: 317-773-8323
Fax: 317-773-5453

Los Angeles
Mission Viejo, CA
Tel: 949-462-9523
Fax: 949-462-9608

Santa Clara
Santa Clara, CA
Tel: 408-961-6444
Fax: 408-961-6445

Toronto
Mississauga, Ontario,
Canada
Tel: 905-673-0699
Fax: 905-673-6509

ASIA/PACIFIC

Asia Pacific Office
Suites 3707-14, 37th Floor
Tower 6, The Gateway
Harbour City, Kowloon
Hong Kong
Tel: 852-2401-1200
Fax: 852-2401-3431

Australia - Sydney
Tel: 61-2-9868-6733
Fax: 61-2-9868-6755

China - Beijing
Tel: 86-10-8569-7000
Fax: 86-10-8528-2104

China - Chengdu
Tel: 86-28-8665-5511
Fax: 86-28-8665-7889

China - Chongqing
Tel: 86-23-8980-9588
Fax: 86-23-8980-9500

China - Hangzhou
Tel: 86-571-2819-3187
Fax: 86-571-2819-3189

China - Hong Kong SAR
Tel: 852-2943-5100
Fax: 852-2401-3431

China - Nanjing
Tel: 86-25-8473-2460
Fax: 86-25-8473-2470

China - Qingdao
Tel: 86-532-8502-7355
Fax: 86-532-8502-7205

China - Shanghai
Tel: 86-21-5407-5533
Fax: 86-21-5407-5066

China - Shenyang
Tel: 86-24-2334-2829
Fax: 86-24-2334-2393

China - Shenzhen
Tel: 86-755-8864-2200
Fax: 86-755-8203-1760

China - Wuhan
Tel: 86-27-5980-5300
Fax: 86-27-5980-5118

China - Xian
Tel: 86-29-8833-7252
Fax: 86-29-8833-7256

China - Xiamen
Tel: 86-592-2388138
Fax: 86-592-2388130

China - Zhuhai
Tel: 86-756-3210040
Fax: 86-756-3210049

ASIA/PACIFIC

India - Bangalore
Tel: 91-80-3090-4444
Fax: 91-80-3090-4123

India - New Delhi
Tel: 91-11-4160-8631
Fax: 91-11-4160-8632

India - Pune
Tel: 91-20-2566-1512
Fax: 91-20-2566-1513

Japan - Osaka
Tel: 81-6-6152-7160
Fax: 81-6-6152-9310

Japan - Tokyo
Tel: 81-3-6880-3770
Fax: 81-3-6880-3771

Korea - Daegu
Tel: 82-53-744-4301
Fax: 82-53-744-4302

Korea - Seoul
Tel: 82-2-554-7200
Fax: 82-2-558-5932 or
82-2-558-5934

Malaysia - Kuala Lumpur
Tel: 60-3-6201-9857
Fax: 60-3-6201-9859

Malaysia - Penang
Tel: 60-4-227-8870
Fax: 60-4-227-4068

Philippines - Manila
Tel: 63-2-634-9065
Fax: 63-2-634-9069

Singapore
Tel: 65-6334-8870
Fax: 65-6334-8850

Taiwan - Hsin Chu
Tel: 886-3-5778-366
Fax: 886-3-5770-955

Taiwan - Kaohsiung
Tel: 886-7-213-7828
Fax: 886-7-330-9305

Taiwan - Taipei
Tel: 886-2-2508-8600
Fax: 886-2-2508-0102

Thailand - Bangkok
Tel: 66-2-694-1351
Fax: 66-2-694-1350

EUROPE

Austria - Wels
Tel: 43-7242-2244-39
Fax: 43-7242-2244-393

Denmark - Copenhagen
Tel: 45-4450-2828
Fax: 45-4485-2829

France - Paris
Tel: 33-1-69-53-63-20
Fax: 33-1-69-30-90-79

Germany - Munich
Tel: 49-89-627-144-0
Fax: 49-89-627-144-44

Italy - Milan
Tel: 39-0331-742611
Fax: 39-0331-466781

Netherlands - Drunen
Tel: 31-416-690399
Fax: 31-416-690340

Spain - Madrid
Tel: 34-91-708-08-90
Fax: 34-91-708-08-91

UK - Wokingham
Tel: 44-118-921-5869
Fax: 44-118-921-5820

11/29/12