

## Switched Capacitor Voltage Inverter with Shutdown

### Features

- Inverts Input Supply Voltage
- 60mA Output Current with a Voltage Drop of 580mV
- 0.45mA Quiescent Current at 3.3V Supply Voltage
- 99% Voltage Conversion Efficiency
- 1.8V to 5V operating range
- Require Only Two Capacitors
- Over-Temperature Protection
- Logic Controlled Shutdown
- 6-Pin SOT-23 Package and TDFN2X2 6-pin Package

### Applications

- Cell Phone
- Small LCD Panels
- Portable Equipment
- Handy-Terminals, PDAs
- Battery-Operated Equipment

### General Description

The G5930 is an unregulated charge-pump voltage inverter which may be used to generate a negative supply from positive input. Input voltages ranging from +1.8V to +5V can be inverted into a -1.8V to -5V output supply. The device is ideal for both battery-powered and board level voltage conversion applications with a typical operating current of 0.45mA at 3.3V supply.

The G5930 can deliver 60mA output current with a voltage drop of 580mV. The parts are over-temperature protected.

Applications include cell phones, PDAs, and other portable equipment. The device is available in a space-saving 6-pin SOT-23 and TDFN2X2 6-pin Package.

### Ordering Information

ORDER NUMBER	MARKING	TEMP. RANGE	PACKAGE (Green)
G5930TBU	5930x	-40°C to 85°C	SOT-23-6
G5930RB1U	5930	-40°C to 85°C	TDFN2X2-6

Note: TB : SOT23-6      RB: TDFN2X2-6  
 1: Bonding Code (only TDFN2X2-6)  
 U: Tape & Reel

### Pin Configuration

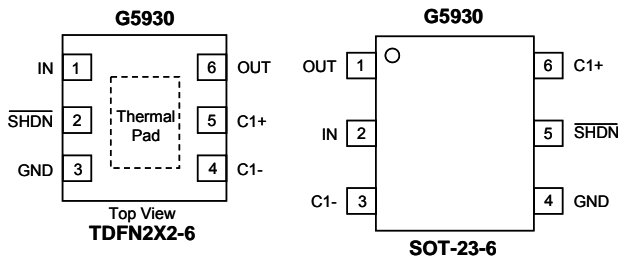

Note: Recommend connecting the Thermal Pad to the Ground for excellent power dissipation.

### Typical Application Circuit

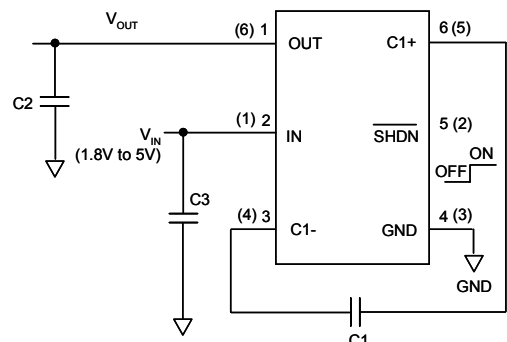

C1, C2, C3: 1 $\mu$ F MLCC (X5R)  
 \*( ) TDFN2X2-6 Package