

Features

- ▶ Switch-mode, single or dual LED controller
- ▶ 5.0V to 55V input voltage range, up to 80V boosted output voltage
- ▶ Boost-, Boost-to-battery-, Buck-to-battery- or SEPIC-topology
- ▶ Constant current regulation implemented
- ▶ Differential high-side sense up to 60V
- ▶ High-frequency PWM dimming capability
- ▶ 10:1 Analog dimming capability for LED binning
- ▶ Digital dimming up to 5000:1 at 100Hz PWM
- ▶ Integrated softstart
- ▶ Advanced In-System Diagnostic (e.g. GND loss, output-overload and highside-feedback diagnostics)
- ▶ Very low sleep mode currents of typ. 8μA
- ▶ Integrated automotive LDOs for 5V & 3.3V
- ▶ AEC-Q100 Qualified
- ▶ Junction temperature range -40°C to +150°C

Applications

- ▶ Automotive LED lighting applications
- ▶ General indoor and outdoor lighting and signals
- ▶ TFT backlighting
- ▶ General current driven applications

General Description

E522.32 and E522.34 are parts of a family of fixed frequency switch-mode high voltage LED power supplies and controllers with high efficiency. Integrated high-side sensing allows topologies related to GND (Boost-to-GND or SEPIC) as well as related to input voltage (Boost-to-battery or Buck-to-battery, particularly in harsh automotive environments).

The switching frequency is adjustable up to 600kHz by an external resistor or can be synchronized in Master-Slave configurations with other devices. The phase shift of 180° between channels essentially reduces EMI. Devices are available as 2-channel with spread spectrum oscillators (E522.32) and as 2-channel without spread spectrum (E522.34) versions to optimize size and effort of the application. Multiple control- and monitoring functions, e.g. short- and open load detection, over-temperature shutdown and undervoltage lockout are implemented.

Ordering Information

Product ID	Oscillator spectrum	Package
E522.32	spread	QFN32L5
E522.34	narrow	QFN32L5

Typical Application Circuit

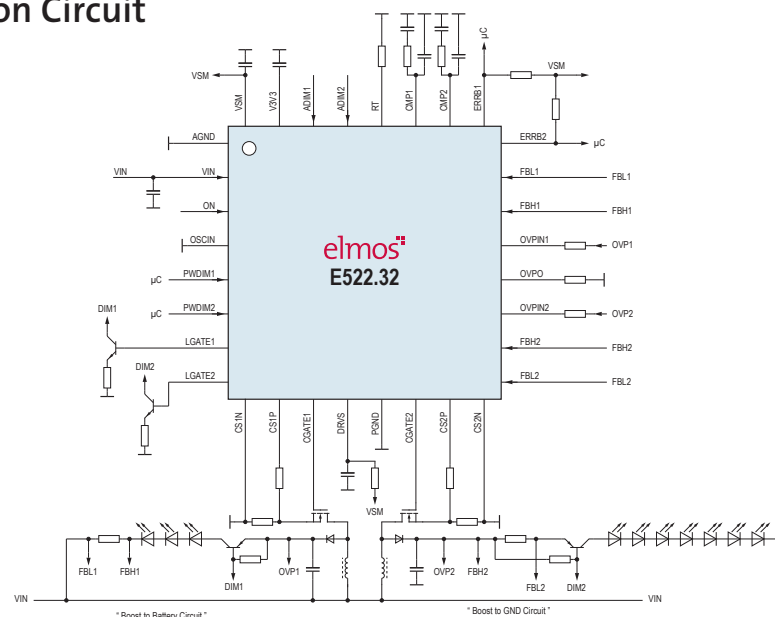

This document contains information on a pre-production product. Elmos Semiconductor AG reserves the right to change specifications and information herein without notice.

Elmos Support 03/2013

Headquarters

Elmos Semiconductor AG

Heinrich-Hertz-Str. 1
44227 Dortmund (Germany)
Phone: +49 (0) 231 / 75 49-100
Fax: +49 (0) 231 / 75 49-149
sales-germany@elmos.com
www.elmos.com

Regional Sales and Application Support Office Munich

Elmos Semiconductor AG

Am Gefluegelhof 12
85716 Unterschleißheim/Eching (Germany)
Phone: +49 (0) 89 / 31 83 70-0
Fax: +49 (0) 89 / 31 83 70-31
sales-germany@elmos.com

Sales and Application Support Office North America

Elmos NA. Inc.

32255 Northwestern Highway, Suite 45
Farmington Hills, MI 48334 (United States)
Phone: +1 (0) 248 / 8 65 32 00
sales-usa@elmosna.com

Sales and Application Support Office Korea and Japan

Elmos Korea

B-1007, U-Space 2, #670 Daewangpangyo-ro,
Sampyoung-dong, Bunddang-gu, Sungnam-si
Kyounggi-do 463-400 Korea
Phone: +82 (0)31 / 7 14 11 31
sales-korea@elmos.com

Sales and Application Support Office China

Elmos Semiconductor Technology (Shanghai) Co., Ltd.

Unit London, 1BF GC Tower,
No. 1088 YuanShen Road,
Pudong New District,
Shanghai, PR China, 200122
Phone: +86 (0) 21 / 51 78 51 88
Fax: +86 (0) 21 / 51 78 52 05
sales-china@elmos.com

中国地区销售与应用支持

艾尔默斯半导体技术（上海）有限公司
中国上海浦东新区源深路1088号
葛洲坝大厦1B楼伦敦单元, 200122
电话: +86 (0) 21 / 51 78 51 88
传真: +86 (0) 21 / 51 78 52 05
sales-china@elmos.com

Sales and Application Support Office Singapore

Elmos Semiconductor Singapore Pte Ltd.

60 Alexandra Terrace
#09-31 The Comtech (Singapore 118502)
Phone: +65 (0) 663 / 5 11 41
Fax: +65 (0) 663 / 5 11 40
sales-singapore@elmos.com

Note Elmos Semiconductor AG (below Elmos) reserves the right to make changes to the product contained in this publication without notice. Elmos assumes no responsibility for the use of any circuits described herein, conveys no licence under any patent or other right, and makes no representation that the circuits are free of patent infringement. While the information in this publication has been checked, no responsibility, however, is assumed for inaccuracies. Elmos does not recommend the use of any of its products in life support applications where the failure or malfunction of the product can reasonably be expected to cause failure of a life-support system or to significantly affect its safety or effectiveness. Products are not authorized for use in such applications.

Copyright © 2013 Elmos. Reproduction, in part or whole, without the prior written consent of Elmos, is prohibited.