

Off-Line, High Voltage EL Lamp Driver

Features

- ▶ Processed with HVCMOS® technology
- ▶ Input voltage up to 200V DC
- ▶ 400V peak-to-peak output voltage
- ▶ Output load up to 350nF (100in² for 3.5nF/in² lamp)
- ▶ Adjustable output lamp frequency
- ▶ Adjustable on/off pulsing frequency

Applications

- ▶ Electronic organizers
- ▶ Handheld portable computers
- ▶ Display signs
- ▶ Portable instrumentation equipment

General Description

The Supertex HV809 is an off-line, high voltage, EL lamp driver integrated circuit designed for driving EL lamps of up to 350nF at 400Hz. The input supply voltage can be a rectified nominal 120V AC source or any other DC source up to 200V. The HV809 will supply the EL lamp with an AC square wave with a peak-to-peak voltage of two times the input DC voltage.

The HV809 has two internal oscillators, a low voltage output linear regulator, and a high voltage output H-bridge. The high voltage output H-bridge frequency is set by an external resistor connected between the REL-Osc and GND pins. The EL lamp is connected between pins VA and VB. For the HV809 in the 8-pin package, an external RC network can be connected between the oscillator's Osc1 and Osc2 pins to pulse the EL lamp on and off.

For detailed circuit and application information please refer to Application Note AN-H36.

Block Diagram

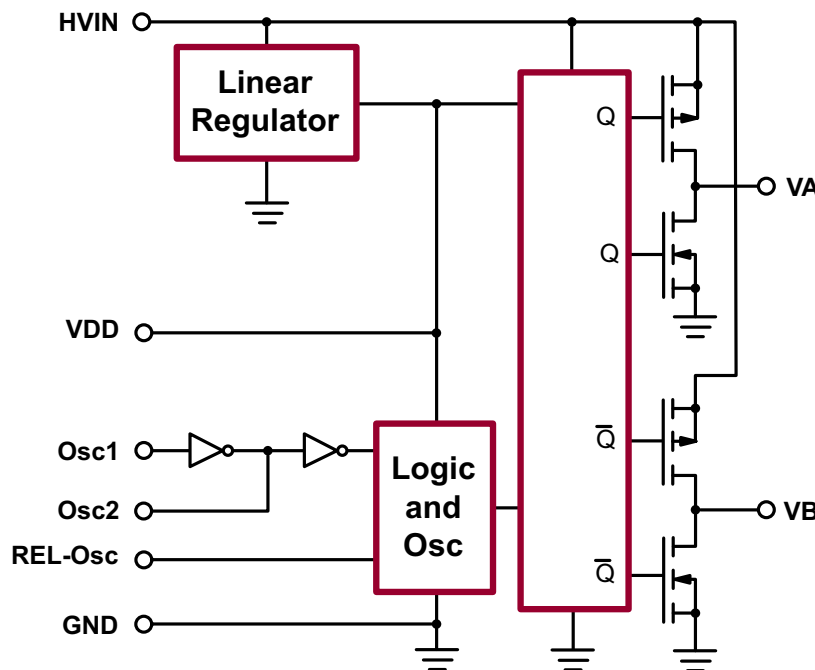

Ordering Information

Part Number	Package Option	Packing
HV809K2-G	7-Lead TO-220	50/Tube
HV809LG-G	8-Lead SOIC	2500/Reel
HV809SG-G	8-Lead SOIC w/ heat slug	2500/Reel

-G denotes a lead (Pb)-free / RoHS compliant package

Pin Configuration

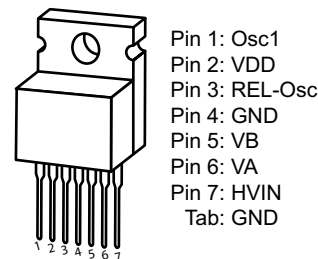

Pin 1: Osc1
 Pin 2: VDD
 Pin 3: REL-Osc
 Pin 4: GND
 Pin 5: VB
 Pin 6: VA
 Pin 7: HVIN
 Tab: GND

7-Lead TO-220
(front view)

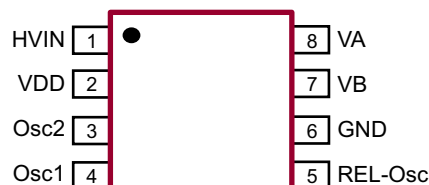

8-Lead SOIC
(top view)

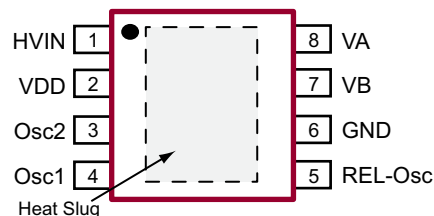

8-Lead SOIC w/ Heat Slug
(top view)
(Heat slug is at ground potential)

Absolute Maximum Ratings

Parameter	Value
HV _{IN} , High voltage input	+210V
V _{DD} , Internal supply voltage	+15V
Operating temperature range	-25°C to +85°C
Storage temperature range	-55°C to +150°C
Power dissipation:	
8-Lead SOIC	500mW
8-Lead SOIC w/ Heat Slug	1.5 Watts
7-Lead TO-220*	15Watts

Absolute Maximum Ratings are those values beyond which damage to the device may occur. Functional operation under these conditions is not implied. Continuous operation of the device at the absolute rating level may affect device reliability. All voltages are referenced to device ground.

* With external heat sink mounted, refer to App Note AN-H36.

Product Marking



L = Lot Number
 YY = Year Sealed
 WW = Week Sealed
 _____ = "Green" Packaging

Package may or may not include the following marks: Si or

7-Lead TO-220



Y = Last Digit of Year Sealed
 WW = Week Sealed
 L = Lot Number
 _____ = "Green" Packaging

Package may or may not include the following marks: Si or

8-Lead SOIC

Typical Thermal Resistance

Package	θ_{ja}
7-Lead TO-220	29°C/W
8-Lead SOIC	101°C/W
8-Lead SOIC w/ heat slug	84°C/W

Recommended Operating Conditions

Sym	Parameter	Min	Typ	Max	Units	Conditions
HV _{IN}	High voltage input	50	-	200	V	---
C _L	Load capacitance	-	-	350	nF	R _{EL} = 1.0MΩ, HV _{IN} = 170V
		-	-	150	nF	R _{EL} = 390kΩ, HV _{IN} = 170V
T _A	Operating temperature	-25	-	85	°C	---

Electrical Characteristics

DC Characteristics (Over recommended operating conditions unless otherwise specified - $T_A = 25^\circ\text{C}$)

Sym	Parameter	Min	Typ	Max	Units	Conditions
I_{IN}	High voltage supply current	-	-	70	mA	$HV_{IN} = 170\text{V}$, $R_{EL} = 1.0\text{M}\Omega$, $C_L = 350\text{nF}$
		-	-	9.0	mA	$HV_{IN} = 170\text{V}$, $R_{EL} = 1.0\text{M}\Omega$, $C_L = 50\text{nF}$
I_{INQ}	Quiescent supply current	-	-	400	μA	$HV_{IN} = 170\text{V}$, $R_{EL} = 1.0\text{M}\Omega$, Osc1 = GND, No Load
		-	-	100	μA	$HV_{IN} = 170\text{V}$, $R_{EL} = 1.0\text{M}\Omega$, Osc1 = V_{DD} , No Load
I_{SINK}	Osc2 sink current*	-	300	-	μA	$V_{Osc2} = 1.0\text{V}$
I_{SOURCE}	Osc2 source current*	-	100	-	μA	$V_{Osc2} = V_{DD} - 1.0\text{V}$
I_{Osc1}	Osc1 logic input leakage current	-	± 10	-	μA	$V_{Osc1} = \text{GND}$ and V_{DD}
$V_{Osc1(hyst)}$	Osc1 hysteresis voltage	-	2.5	-	V	---
V_{A-B}	Min differential output voltage across lamp	-	-	400	V	$HV_{IN} = 200\text{V}$
V_{DD}	Internal supply voltage	8.0	10	12	V	No load on V_{DD}
$I_{DD(OUT)}$	Output V_{DD} current	4.0	-	-	mA	For HV809K2, $\Delta V_{DD} = 1.0\text{V}$

* I_{SINK} and I_{SOURCE} are not valid for the TO-220 package.

AC Characteristics (Over recommended operating conditions unless otherwise specified - $T_A = 25^\circ\text{C}$)

Sym	Parameter	Min	Typ	Max	Units	Conditions
f_{EL}	V_{A-B} output drive frequency	320	400	480	Hz	$R_{EL} = 1.0\text{M}\Omega$, Osc1 = GND, $C_L = 350\text{nF}$
		0.8	1.0	1.2	kHz	$R_{EL} = 390\text{k}\Omega$, Osc1 = GND, $C_L = 150\text{nF}$
t_r	Output rise time	-	180	250	μs	$C_L = 150\text{nF}$, $HV_{IN} = 170\text{V}$
t_f	Output fall time	-	50	100	μs	$C_L = 150\text{nF}$, $HV_{IN} = 170\text{V}$

Function Table

Input	Outputs	
	VA	VB
Osc1		
GND	Enabled	Enabled
VDD	Disabled	Disabled

Figure 1. AC Off-Line EL Lamp

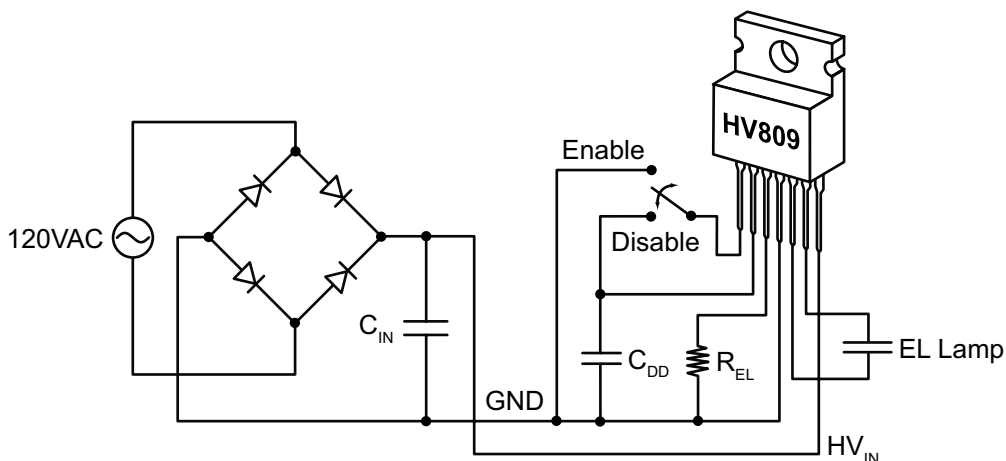

Figure 2. Pulsing EL Lamp

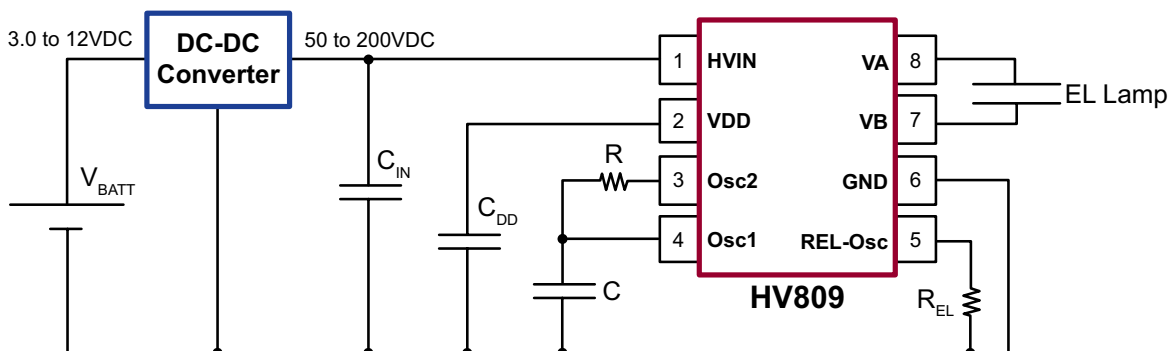
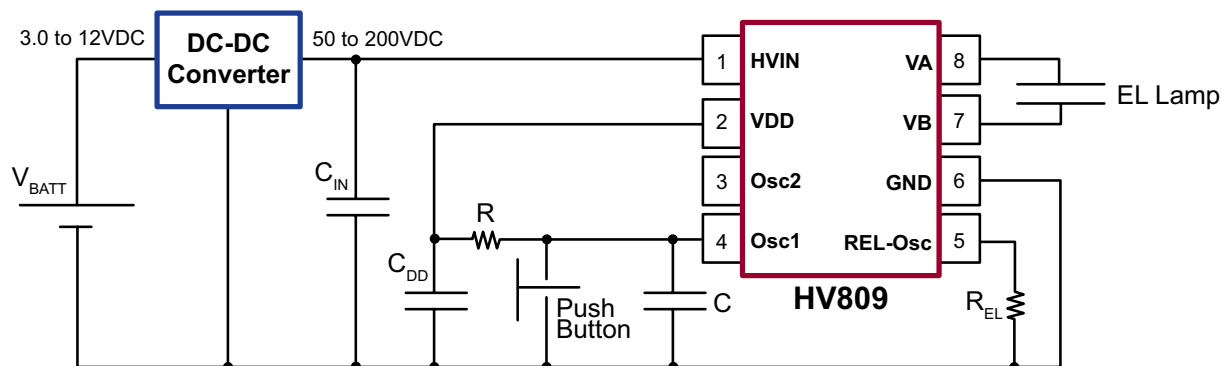
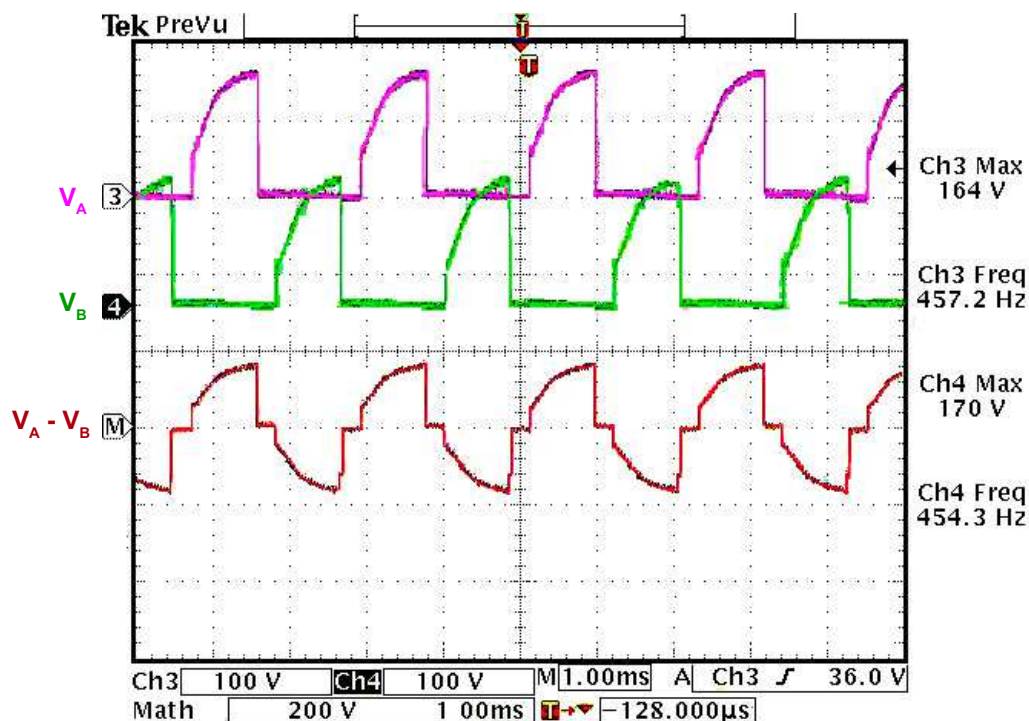

Figure 3. Push-Button, Delayed Turn Off



Typical Waveform on V_A , V_B , and Differential Waveform $V_A - V_B$

($HV_{IN} = 170V$, $R_{EL} = 1.0M\Omega$, and $C_L = 350nF$)



Function Table

Pin Name	Description
Osc1	The Output H-bridge can be enabled and disabled by connecting the Osc1 pin to the GND and VDD pins. The output can be left enabled by connecting the Osc1 pin to GND.
Osc2	The RC network can be connected between the oscillator's Osc1 and Osc2 pins to pulse the EL lamp on and off.
VDD	Internal supply voltage.
REL-Osc	EL lamp frequency is controlled via an external R_{EL} resistor connected between the REL-Osc and GND pins of the device.
VB	VB side of the EL lamp driver H-bridge. Connection for one of the EL lamp terminals.
VA	VA side of the EL lamp driver H-bridge. Connection for one of the EL lamp terminals.
HVIN	High voltage input supply pin.
GND	Ground pin.

7-Lead TO-220 Package Outline (K2)

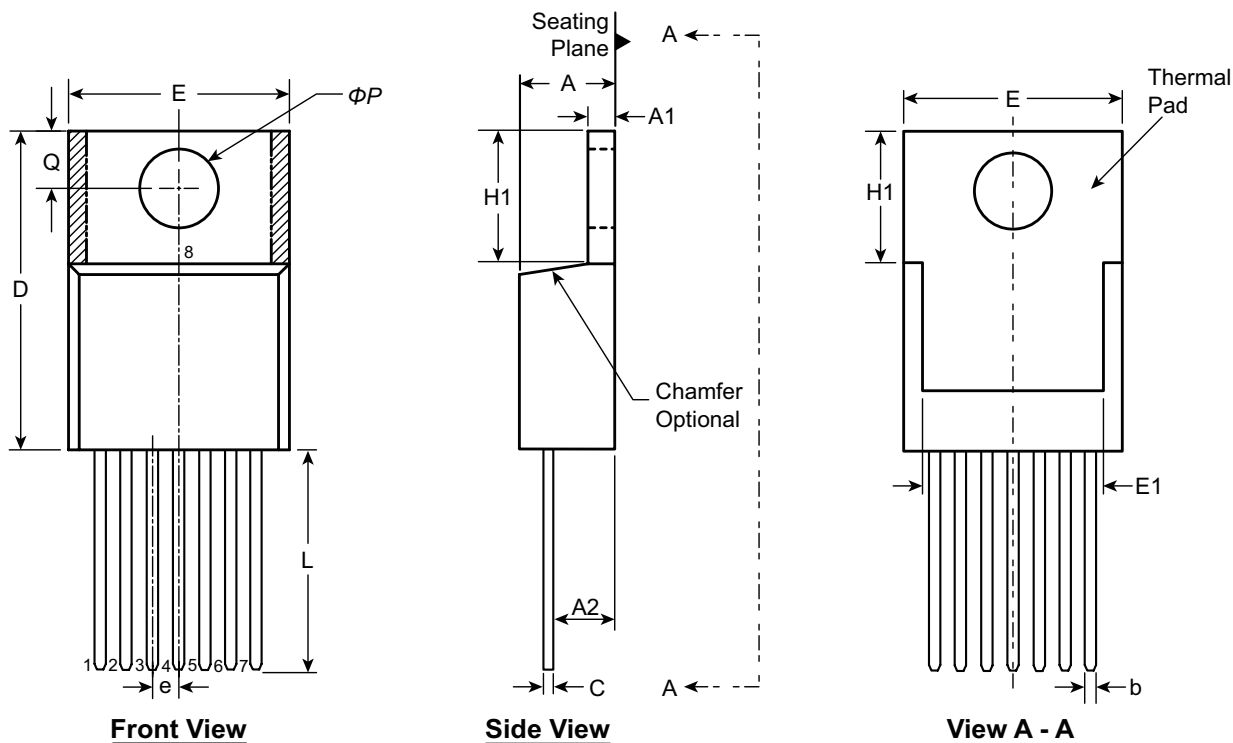

Symbol		A	A1	A2	b	c	D	E	E1	e	H1	L	Q	ΦP	
Dimension (inches)	MIN	.160	.045	.090	.023	.015	.560	.385	.300 REF	.045	.234	.540	.103	.146	
	NOM	-	-	-	-	-	-	-		-	-	-	-	-	-
	MAX	.190	.055	.115	.037	.022	.590	.415		.055	.258	.560	.113	.156	

Drawings not to scale.

Supertex Doc. #: DSPD-7TO220K2, Version NR090308.

8-Lead SOIC (Narrow Body) Package Outline (LG)

4.90x3.90mm body, 1.75mm height (max), 1.27mm pitch

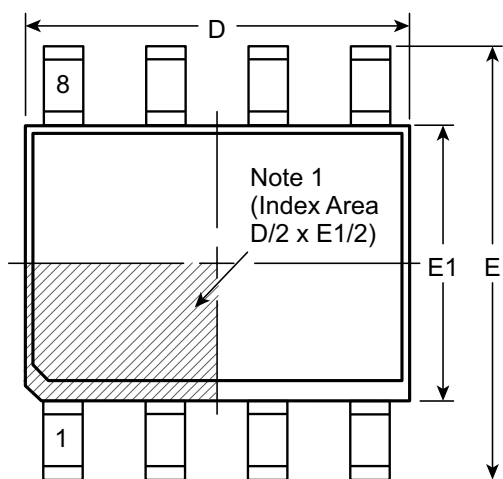

Top View

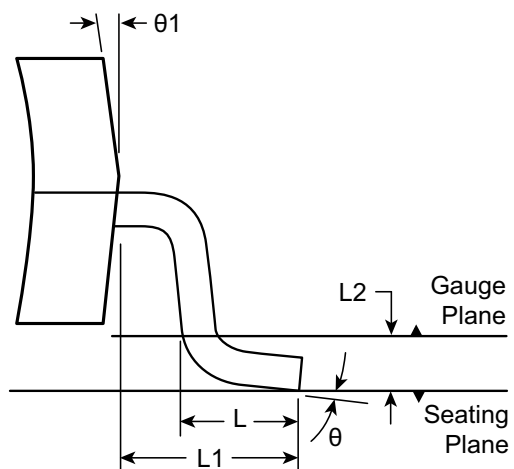

View B

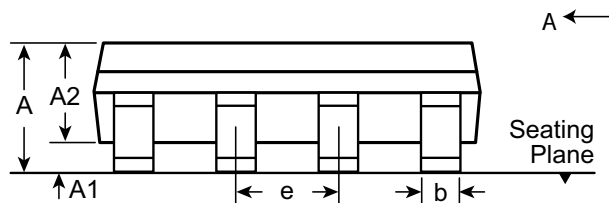

Side View

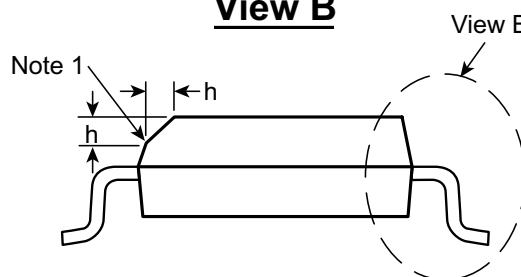

View A-A

Note:
 1. This chamfer feature is optional. A Pin 1 identifier must be located in the index area indicated. The Pin 1 identifier can be: a molded mark/identifier; an embedded metal marker; or a printed indicator.

Symbol	A	A1	A2	b	D	E	E1	e	h	L	L1	L2	θ	θ_1	
Dimension (mm)	MIN	1.35*	0.10	1.25	0.31	4.80*	5.80*	3.80*	1.27 BSC	0.25	0.40	1.04 REF	0.25 BSC	0°	5°
	NOM	-	-	-	-	4.90	6.00	3.90		-	-			-	-
	MAX	1.75	0.25	1.65*	0.51	5.00*	6.20*	4.00*		0.50	1.27			8°	15°

JEDEC Registration MS-012, Variation AA, Issue E, Sept. 2005.

* This dimension is not specified in the JEDEC drawing.

Drawings are not to scale.

Supertex Doc. #: DSPD-8SOLGTG, Version I041309.

8-Lead SOIC (Narrow Body w/Heat Slug) Package Outline (SG)

4.90x3.90mm body, 1.70mm height (max), 1.27mm pitch

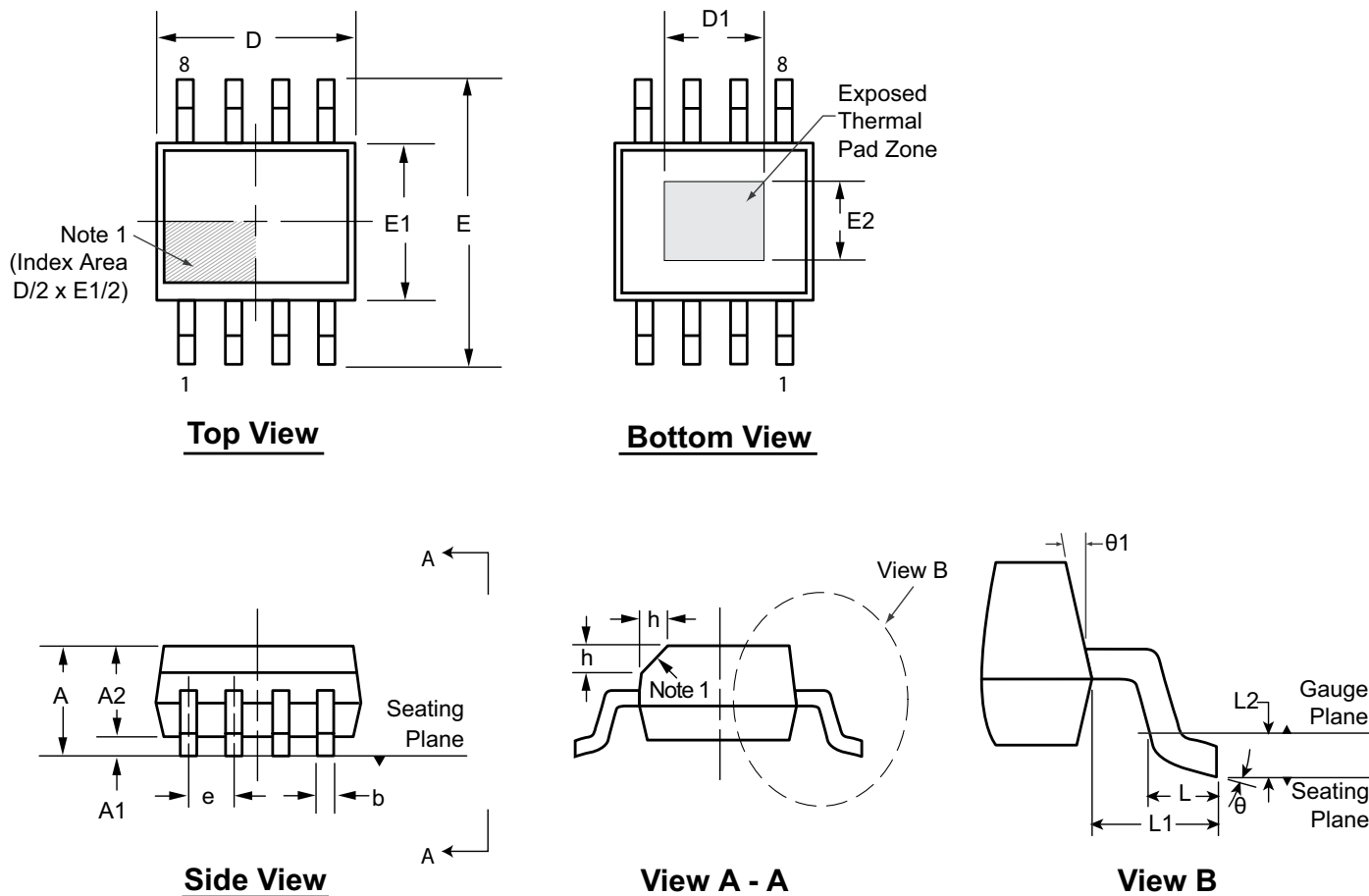

Note:
 1. If optional chamfer feature is not present, a Pin 1 identifier must be located in the index area indicated. The Pin 1 identifier can be: a molded mark/identifier; an embedded metal marker; or a printed indicator.

Symbol	A	A1	A2	b	D	D1	E	E1	E2	e	h	L	L1	L2	θ	θ1			
Dimension (mm)	MIN	1.25*	0.00	1.25	0.31	4.80*	3.30†	5.80*	3.80*	2.29†	1.27 BSC	0.25	0.40	1.04 REF	0.25 BSC	0°	5°		
	NOM	-	-	-	-	4.90	-	6.00	3.90	-		-	-			-	-	-	-
	MAX	1.70	0.15	1.55*	0.51	5.00*	3.81†	6.20*	4.00*	2.79†		0.50	1.27			-	-	8°	15°

JEDEC Registration MS-012, Variation BA, Issue E, Sept. 2005.

* This dimension is not specified in the JEDEC drawing.

† This dimension differs from the JEDEC drawing.

Drawings not to scale.

Supertex Doc. #: DSPD-8SOSG, Version D041009.

(The package drawing(s) in this data sheet may not reflect the most current specifications. For the latest package outline information go to <http://www.supertex.com/packaging.html>.)

Supertex inc. does not recommend the use of its products in life support applications, and will not knowingly sell them for use in such applications unless it receives an adequate "product liability indemnification insurance agreement." Supertex inc. does not assume responsibility for use of devices described, and limits its liability to the replacement of the devices determined defective due to workmanship. No responsibility is assumed for possible omissions and inaccuracies. Circuitry and specifications are subject to change without notice. For the latest product specifications refer to the Supertex inc. (website: <http://www.supertex.com>)