

KM416C1004C, KM416C1204C KM416V1004C, KM416V1204C

CMOS DRAM

1M x 16Bit CMOS Dynamic RAM with Extended Data Out

DESCRIPTION

This is a family of 1,048,576 x 16 bit Extended Data Out CMOS DRAMs. Extended Data Out Mode offers high speed random access of memory cells within the same row, so called Hyper Page Mode. Power supply voltage (+5.0V or +3.3V), refresh cycle (1K Ref. or 4K Ref.), access time (-45, -5 or -6), power consumption(Normal or Low power) and package type(SOJ or TSOP-II) are optional features of this family. All of this family have $\overline{\text{CAS}}$ -before- $\overline{\text{RAS}}$ refresh, $\overline{\text{RAS}}$ -only refresh and Hidden refresh capabilities. Furthermore, Self-refresh operation is available in L-version. This 1Mx16 EDO Mode DRAM family is fabricated using Samsung's advanced CMOS process to realize high band-width, low power consumption and high reliability. It may be used as graphic memory unit for microcomputer, personal computer and portable machines.

FEATURES

• Part Identification

- KM416C1004C/C-L (5V, 4K Ref.)
- KM416C1204C/C-L (5V, 1K Ref.)
- KM416V1004C/C-L (3.3V, 4K Ref.)
- KM416V1204C/C-L (3.3V, 1K Ref.)

• Active Power Dissipation

Unit : mW

Speed	3.3V		5V	
	4K	1K	4K	1K
-45	-	-	550	825
-5	324	504	495	770
-6	288	468	440	715

- Extended Data Out Mode operation (Fast Page Mode with Extended Data Out)
- 2 $\overline{\text{CAS}}$ Byte/Word Read/Write operation
- $\overline{\text{CAS}}$ -before- $\overline{\text{RAS}}$ refresh capability
- $\overline{\text{RAS}}$ -only and Hidden refresh capability
- Self-refresh capability (L-ver only)
- TTL(5V)/LVTTTL(3.3V) compatible inputs and outputs
- Early Write or output enable controlled write
- JEDEC Standard pinout
- Available in plastic SOJ 400mil and TSOP(II) packages
- Single +5V±10% power supply (5V product)
- Single +3.3V±0.3V power supply (3.3V product)

• Refresh Cycles

Part NO.	V _{CC}	Refresh cycle	Refresh period	
			Normal	L-ver
C1004C	5V	4K	64ms	128ms
V1004C	3.3V			
C1204C	5V	1K	16ms	
V1204C	3.3V			

• Performance Range

Speed	t _{RAC}	t _{CAC}	t _{RC}	t _{HPC}	Remark
-45	45ns	13ns	69ns	16ns	5V/3.3V
-5	50ns	15ns	84ns	20ns	5V/3.3V
-6	60ns	17ns	104ns	25ns	5V/3.3V

FUNCTIONAL BLOCK DIAGRAM

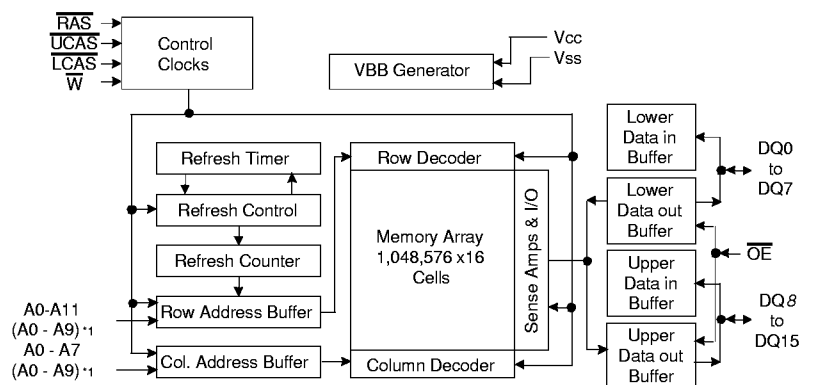

Note) *1 : 1K Refresh

SAMSUNG ELECTRONICS CO., LTD. reserves the right to change products and specifications without notice.



ELECTRONICS

PIN CONFIGURATION (Top Views)

• KM416C/V10(2)04CJ

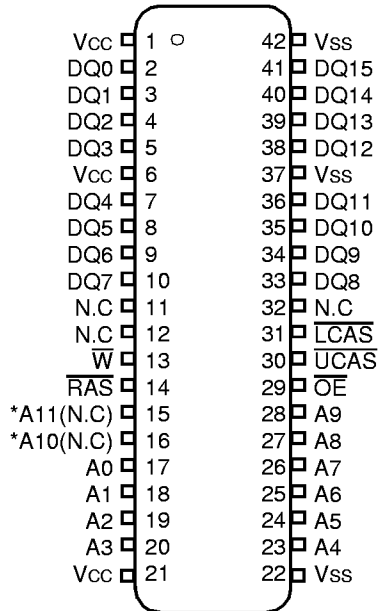

• KM416C/V10(2)04CT

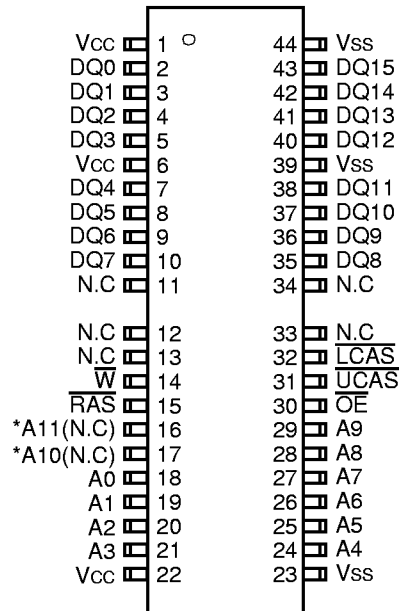

*A10 and A11 are N.C for KM416C/V1204C(5V/3.3V, 1K Ref. product)

J : 400mil 42 SOJ

T : 400mil 50(44) TSOP II

Pin Name	Pin Function
A0 - A11	Address Inputs (4K Product)
A0 - A9	Address Inputs (1K Product)
DQ0 - 15	Data In/Out
Vss	Ground
\overline{RAS}	Row Address Strobe
\overline{UCAS}	Upper Column Address Strobe
\overline{LCAS}	Lower Column Address Strobe
\overline{W}	Read/Write Input
\overline{OE}	Data Output Enable
Vcc	Power(+5V)
	Power(+3.3V)
N.C	No Connection

KM416C1004C, KM416C1204C KM416V1004C, KM416V1204C

CMOS DRAM

ABSOLUTE MAXIMUM RATINGS

Parameter	Symbol	Rating		Units
		3.3V	5V	
Voltage on any pin relative to Vss	V _{IN} , V _{OUT}	-0.5 to +4.6	-1.0 to +7.0	V
Voltage on Vcc supply relative to Vss	V _{CC}	-0.5 to +4.6	-1.0 to +7.0	V
Storage Temperature	T _{stg}	-55 to +150	-55 to +150	°C
Power Dissipation	P _D	1	1	W
Short Circuit Output Current	I _{OS}	50	50	mA

* Permanent device damage may occur if "ABSOLUTE MAXIMUM RATINGS" are exceeded. Functional operation should be restricted to the conditions as detailed in the operational sections of this data sheet. Exposure to absolute maximum rating conditions for extended periods may affect device reliability.

RECOMMENDED OPERATING CONDITIONS (Voltage referenced to Vss, T_A= 0 to 70°C)

Parameter	Symbol	3.3V			5V			Units
		Min	Typ	Max	Min	Typ	Max	
Supply Voltage	V _{CC}	3.0	3.3	3.6	4.5	5.0	5.5	V
Ground	V _{SS}	0	0	0	0	0	0	V
Input High Voltage	V _{IH}	2.0	-	V _{CC} +0.3 ^{*1}	2.4	-	V _{CC} +1.0 ^{*1}	V
Input Low Voltage	V _{IL}	-0.3 ^{*2}	-	0.8	-1.0 ^{*2}	-	0.8	V

*1 : V_{CC}+1.3V/15ns(3.3V), V_{CC}+2.0V/20ns(5V), Pulse width is measured at V_{CC}

*2 : -1.3V/15ns(3.3V), -2.0V/20ns(5V), Pulse width is measured at V_{SS}

DC AND OPERATING CHARACTERISTICS (Recommended operating conditions unless otherwise noted.)

Max	Parameter	Symbol	Min	Max	Units
3.3V	Input Leakage Current (Any input 0≤V _{IN} ≤V _{IN} +0.3V, all other input pins not under test=0 Volt)	I _{I(L)}	-5	5	μA
	Output Leakage Current (Data out is disabled, 0V≤V _{OUT} ≤V _{CC})	I _{O(L)}	-5	5	μA
	Output High Voltage Level(I _{OH} =-2mA)	V _{OH}	2.4	-	V
	Output Low Voltage Level(I _{OL} =2mA)	V _{OL}	-	0.4	V
5V	Input Leakage Current (Any input 0≤V _{IN} ≤V _{IN} +0.5V, all other input pins not under test=0 Volt)	I _{I(L)}	-5	5	μA
	Output Leakage Current (Data out is disabled, 0V≤V _{OUT} ≤V _{CC})	I _{O(L)}	-5	5	μA
	Output High Voltage Level(I _{OH} =-5mA)	V _{OH}	2.4	-	V
	Output Low Voltage Level(I _{OL} =4.2mA)	V _{OL}	-	0.4	V



ELECTRONICS

KM416C1004C, KM416C1204C KM416V1004C, KM416V1204C

CMOS DRAM

DC AND OPERATING CHARACTERISTICS (Continued)

Symbol	Power	Speed	Max				Units
			KM416V1004C	KM416V1204C	KM416C1004C	KM416C1204C	
I _{CC1}	Don't care	-45	100	150	100	150	mA
		-5	90	140	90	140	mA
		-6	80	130	80	130	mA
I _{CC2}	Normal L	Don't care	1	1	2	2	mA
			1	1	1	1	mA
I _{CC3}	Don't care	-45	100	150	100	150	mA
		-5	90	140	90	140	mA
		-6	80	130	80	130	mA
I _{CC4}	Don't care	-45	110	110	110	110	mA
		-5	100	100	100	100	mA
		-6	90	90	90	90	mA
I _{CC5}	Normal L	Don't care	0.5	0.5	1	1	mA
			200	200	200	200	µA
I _{CC6}	Don't care	-45	100	150	110	150	mA
		-5	90	140	90	140	mA
		-6	80	130	80	130	mA
I _{CC7}	L	Don't care	300	200	350	250	µA
I _{CC8}	L	Don't care	150	150	200	200	µA

I_{CC1}* : Operating Current ($\overline{\text{RAS}}$ and $\overline{\text{UCAS}}$, $\overline{\text{LCAS}}$, Address cycling @t_{RC}=min.)

I_{CC2} : Standby Current ($\overline{\text{RAS}}=\overline{\text{UCAS}}=\overline{\text{LCAS}}=\overline{\text{W}}=V_{\text{IH}}$)

I_{CC3}* : $\overline{\text{RAS}}$ -only Refresh Current ($\overline{\text{UCAS}}=\overline{\text{LCAS}}=V_{\text{IH}}$, $\overline{\text{RAS}}$, Address cycling @t_{RC}=min.)

I_{CC4}* : Hyper Page Mode Current ($\overline{\text{RAS}}=V_{\text{IL}}$, $\overline{\text{UCAS}}$ or $\overline{\text{LCAS}}$, Address cycling @t_{HPC}=min.)

I_{CC5} : Standby Current ($\overline{\text{RAS}}=\overline{\text{UCAS}}=\overline{\text{LCAS}}=\overline{\text{W}}=V_{\text{CC}}-0.2\text{V}$)

I_{CC6}* : $\overline{\text{CAS}}$ -Before- $\overline{\text{RAS}}$ Refresh Current ($\overline{\text{RAS}}$, $\overline{\text{UCAS}}$ or $\overline{\text{LCAS}}$ cycling @t_{RC}=min.)

I_{CC7} : Battery back-up current, Average power supply current, Battery back-up mode

Input high voltage(V_{IH})=V_{CC}-0.2V, Input low voltage(V_{IL})=0.2V, $\overline{\text{UCAS}}$, $\overline{\text{LCAS}}=0.2\text{V}$,

DQ=Don't care, T_{RC}=31.25µs(4K/L-ver), 125µs(1K/L-ver)

T_{RAS}=T_{RASmin}~300ns

I_{CC8} : Self Refresh Current

$\overline{\text{RAS}}=\overline{\text{UCAS}}=\overline{\text{LCAS}}=V_{\text{IL}}$, $\overline{\text{W}}=\overline{\text{OE}}=A_0 \sim A_{11}=V_{\text{CC}}-0.2\text{V}$ or 0.2V,

DQ0 ~ DQ15=V_{CC}-0.2V, 0.2V or Open

*Note : I_{CC1}, I_{CC3}, I_{CC4} and I_{CC6} are dependent on output loading and cycle rates. Specified values are obtained with the output open. I_{CC} is specified as an average current. In I_{CC1}, I_{CC3} and I_{CC6}, address can be changed maximum once while $\overline{\text{RAS}}=V_{\text{IL}}$. In I_{CC4}, address can be changed maximum once within one Hyper page mode cycle time, t_{HPC}.



ELECTRONICS

KM416C1004C, KM416C1204C KM416V1004C, KM416V1204C

CMOS DRAM

CAPACITANCE (TA=25°C, VCC=5V or 3.3V, f=1MHz)

Parameter	Symbol	Min	Max	Units
Input capacitance [A0 ~ A11]	CIN1	-	5	pF
Input capacitance [$\overline{\text{RAS}}$, $\overline{\text{UCAS}}$, $\overline{\text{LCAS}}$, $\overline{\text{W}}$, $\overline{\text{OE}}$]	CIN2	-	7	pF
Output capacitance [DQ0 - DQ15]	CdQ	-	7	pF

AC CHARACTERISTICS (0°C ≤ TA ≤ 70°C, See note 1,2)

Test condition (5V device) : VCC=5.0V±10%, Vih/Vil=2.4/0.8V, Voh/Vol=2.0/0.8V

Test condition (3.3V device) : VCC=3.3V±0.3V, Vih/Vil=2.2/0.7V, Voh/Vol=2.0/0.8V

Parameter	Symbol	-45		-5		-6		Units	Notes
		Min	Max	Min	Max	Min	Max		
Random read or write cycle time	tRC	79		84		104		ns	
Read-modify-write cycle time	tRWC	105		115		140		ns	
Access time from $\overline{\text{RAS}}$	tRAC		45		50		60	ns	3,4,10
Access time from $\overline{\text{CAS}}$	tCAC		14		15		17	ns	3,4,5
Access time from column address	tAA		23		25		30	ns	3,10
$\overline{\text{CAS}}$ to output in Low-Z	tCLZ	3		3		3		ns	3
Output buffer turn-off delay from $\overline{\text{CAS}}$	tCEZ	3	13	3	13	3	15	ns	6,19
$\overline{\text{OE}}$ to output in Low-Z	tOLZ	3		3		3		ns	3
Transition time (rise and fall)	tT	2	50	2	50	2	50	ns	2
$\overline{\text{RAS}}$ precharge time	tRP	30		30		40		ns	
$\overline{\text{RAS}}$ pulse width	tRAS	45	10K	50	10K	60	10K	ns	
$\overline{\text{RAS}}$ hold time	tRSH	13		13		17		ns	
$\overline{\text{CAS}}$ hold time	tCSH	36		40		50		ns	
$\overline{\text{CAS}}$ pulse width	tCAS	7	10K	8	10K	10	10K	ns	18
$\overline{\text{RAS}}$ to $\overline{\text{CAS}}$ delay time	tRCD	19	31	20	35	20	43	ns	4
$\overline{\text{RAS}}$ to column address delay time	tRAD	14	22	15	25	15	30	ns	10
$\overline{\text{CAS}}$ to $\overline{\text{RAS}}$ precharge time	tCRP	5		5		5		ns	
Row address set-up time	tASR	0		0		0		ns	
Row address hold time	tRAH	9		10		10		ns	
Column address set-up time	tASC	0		0		0		ns	11
Column address hold time	tCAH	7		8		10		ns	11
Column address to $\overline{\text{RAS}}$ lead time	tRAL	23		25		30		ns	
Read command set-up time	tRCS	0		0		0		ns	
Read command hold time referenced to $\overline{\text{CAS}}$	tRCH	0		0		0		ns	8
Read command hold time referenced to $\overline{\text{RAS}}$	tRRH	0		0		0		ns	8
Write command hold time	tWCH	8		10		10		ns	
Write command pulse width	tWP	8		10		10		ns	
Write command to $\overline{\text{RAS}}$ lead time	tRWL	10		13		15		ns	
Write command to $\overline{\text{CAS}}$ lead time	tCWL	7		8		10		ns	14



ELECTRONICS

KM416C1004C, KM416C1204C
KM416V1004C, KM416V1204C

CMOS DRAM

AC CHARACTERISTICS (Continued)

Parameter	Symbol	-45		-5		-6		Units	Notes
		Min	Max	Min	Max	Min	Max		
Data set-up time	tDS	0		0		0		ns	9,17
Data hold time	tDH	7		8		10		ns	9,17
Refresh period (1K, Normal)	tREF		16		16		16	ms	
Refresh period (4K, Normal)	tREF		64		64		64	ms	
Refresh period (L-ver)	tREF		128		128		128	ms	
Write command set-up time	twCS	0		0		0		ns	7
$\overline{\text{CAS}}$ to $\overline{\text{W}}$ delay time	tcWD	28		32		36		ns	7,13
$\overline{\text{RAS}}$ to $\overline{\text{W}}$ delay time	trWD	59		67		79		ns	7
Column address $\overline{\text{W}}$ delay time	tAWD	37		42		49		ns	7
$\overline{\text{CAS}}$ precharge to $\overline{\text{W}}$ delay time	tcpWD	39		47		54		ns	7
$\overline{\text{CAS}}$ set-up time ($\overline{\text{CAS}}$ -before- $\overline{\text{RAS}}$ refresh)	tCSR	5		5		5		ns	15
$\overline{\text{CAS}}$ hold time ($\overline{\text{CAS}}$ -before- $\overline{\text{RAS}}$ refresh)	tCHR	10		10		10		ns	16
$\overline{\text{RAS}}$ to $\overline{\text{CAS}}$ precharge time	trPC	5		5		5		ns	
Access time from $\overline{\text{CAS}}$ precharge	tCPA		25		28		35	ns	3
Hyper Page mode cycle time	tHPC	18		20		25		ns	18
Hyper Page read-modify-write cycle time	tHPRWC	39		47		56		ns	18
$\overline{\text{CAS}}$ precharge time (Hyper Page cycle)	tCP	7		8		10		ns	12
$\overline{\text{RAS}}$ pulse width (Hyper Page cycle)	trASP	45	200K	50	200K	60	200K	ns	
$\overline{\text{RAS}}$ hold time from $\overline{\text{CAS}}$ precharge	trHCP	27		30		35		ns	
$\overline{\text{OE}}$ access time	toEA		13		13		15	ns	3
$\overline{\text{OE}}$ to data delay	toED	10		13		15		ns	
Output buffer turn off delay time from $\overline{\text{OE}}$	toEZ	3	13	3	13	3	15	ns	6
$\overline{\text{OE}}$ command hold time	toEH	10		13		15		ns	
Output data hold time	tDOH	4		5		5		ns	
Output buffer turn off delay from $\overline{\text{RAS}}$	trEZ	3	13	3	13	3	15	ns	6,19
Output buffer turn off delay from $\overline{\text{W}}$	tWEZ	3	13	3	13	3	15	ns	6
$\overline{\text{W}}$ to data delay	twED	15		15		15		ns	
$\overline{\text{OE}}$ to $\overline{\text{CAS}}$ hold time	toCH	5		5		5		ns	
$\overline{\text{CAS}}$ hold time to $\overline{\text{OE}}$	tCHO	5		5		5		ns	
$\overline{\text{OE}}$ precharge time	toEP	5		5		5		ns	
$\overline{\text{W}}$ pulse width (Hyper Page Cycle)	twPE	5		5		5		ns	
$\overline{\text{RAS}}$ pulse width ($\overline{\text{C}}$ -B- $\overline{\text{R}}$ self refresh)	trASS	100		100		100		us	20,21,22
$\overline{\text{RAS}}$ precharge time ($\overline{\text{C}}$ -B- $\overline{\text{R}}$ self refresh)	trPS	79		90		110		ns	20,21,22
$\overline{\text{CAS}}$ hold time ($\overline{\text{C}}$ -B- $\overline{\text{R}}$ self refresh)	tCHS	-50		-50		-50		ns	20,21,22



NOTES

1. An initial pause of 200 μ s is required after power-up followed by any 8 $\overline{\text{RAS}}$ -only refresh or $\overline{\text{CAS}}$ -before- $\overline{\text{RAS}}$ refresh cycles before proper device operation is achieved.
2. Input voltage levels are V_{ih}/V_{il} . $V_{ih}(\text{min})$ and $V_{il}(\text{max})$ are reference levels for measuring timing of input signals. Transition times are measured between $V_{ih}(\text{min})$ and $V_{il}(\text{max})$ and are assumed to be 2ns for all inputs.
3. Measured with a load equivalent to 2 TTL(5V)/1TTL(3.3V) loads and 100pF.
4. Operation within the $t_{\text{RCD}}(\text{max})$ limit insures that $t_{\text{RAC}}(\text{max})$ can be met. $t_{\text{RCD}}(\text{max})$ is specified as a reference point only. If t_{RCD} is greater than the specified $t_{\text{RCD}}(\text{max})$ limit, then access time is controlled exclusively by t_{CAC} .
5. Assumes that $t_{\text{RCD}} \geq t_{\text{RCD}}(\text{max})$.
6. This parameter defines the time at which the output achieves the open circuit condition and is not referenced to V_{oh} or V_{ol} .
7. t_{WCS} , t_{RWD} , t_{CWD} , t_{AWD} and t_{CPWD} are non restrictive operating parameters. They are included in the data sheet as electrical characteristics only. If $t_{\text{WCS}} \geq t_{\text{WCS}}(\text{min})$, the cycle is an early write cycle and the data output will remain high impedance for the duration of the cycle. If $t_{\text{CWD}} \geq t_{\text{CWD}}(\text{min})$, $t_{\text{RWD}} \geq t_{\text{RWD}}(\text{min})$, $t_{\text{AWD}} \geq t_{\text{AWD}}(\text{min})$ and $t_{\text{CPWD}} \geq t_{\text{CPWD}}(\text{min})$, then the cycle is a read-modify-write cycle and the data output will contain the data read from the selected address. If neither of the above conditions is satisfied, the condition of the data out is indeterminate.
8. Either t_{RCH} or t_{RRH} must be satisfied for a read cycle.
9. These parameters are referenced to $\overline{\text{CAS}}$ falling edge in early write cycles and to $\overline{\text{W}}$ falling edge in $\overline{\text{OE}}$ controlled write cycle and read-modify-write cycles.
10. Operation within the $t_{\text{RAD}}(\text{max})$ limit insures that $t_{\text{RAC}}(\text{max})$ can be met. $t_{\text{RAD}}(\text{max})$ is specified as a reference point only. If t_{RAD} is greater than the specified $t_{\text{RAD}}(\text{max})$ limit, then access time is controlled by t_{AA} .

KM416C/V10(2)04C/C-L Truth Table

$\overline{\text{RAS}}$	$\overline{\text{LCAS}}$	$\overline{\text{UCAS}}$	$\overline{\text{W}}$	$\overline{\text{OE}}$	DQ0 - DQ7	DQ8-DQ15	STATE
H	X	X	X	X	Hi-Z	Hi-Z	Standby
L	H	H	X	X	Hi-Z	Hi-Z	Refresh
L	L	H	H	L	DQ-OUT	Hi-Z	Byte Read
L	H	L	H	L	Hi-Z	DQ-OUT	Byte Read
L	L	L	H	L	DQ-OUT	DQ-OUT	Word Read
L	L	H	L	H	DQ-IN	-	Byte Write
L	H	L	L	H	-	DQ-IN	Byte Write
L	L	L	L	H	DQ-IN	DQ-IN	Word Write
L	L	L	H	H	Hi-Z	Hi-Z	-

11. tASC, tCAH are referenced to the earlier $\overline{\text{CAS}}$ falling edge.
12. tCP is specified from the later $\overline{\text{CAS}}$ rising edge in the previous cycle to the earlier $\overline{\text{CAS}}$ falling edge in the next cycle.
13. tcWD is referenced to the later $\overline{\text{CAS}}$ falling edge at word read-modify-write cycle.
14. tcWL is specified from $\overline{\text{W}}$ falling edge to the earlier $\overline{\text{CAS}}$ rising edge.
15. tCSR is referenced to the earlier $\overline{\text{CAS}}$ falling edge before $\overline{\text{RAS}}$ transition low.
16. tCHR is referenced to the later $\overline{\text{CAS}}$ rising edge after $\overline{\text{RAS}}$ transition low.

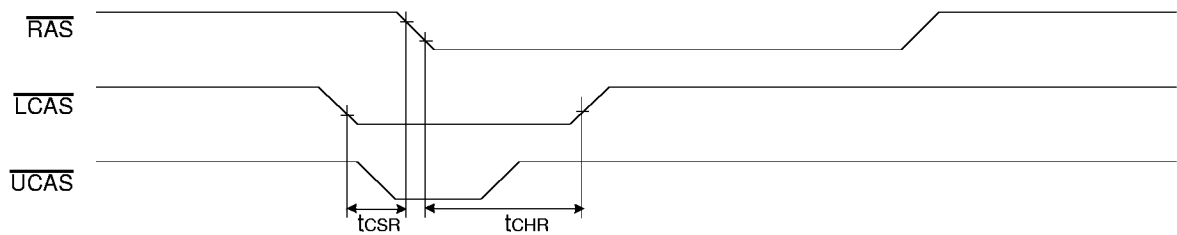

17. tDS, tDH is independently specified for lower byte DQ(0-7), upper byte DQ(8-15)
18. tASC ≥ 6ns, assume tT = 2.0ns.
19. If $\overline{\text{RAS}}$ goes to high before $\overline{\text{CAS}}$ high going, the open circuit condition of the output is achieved by $\overline{\text{CAS}}$ high going.
If $\overline{\text{CAS}}$ goes to high before $\overline{\text{RAS}}$ high going, the open circuit condition of the output is achieved by $\overline{\text{RAS}}$ high going.
20. If tRASS ≥ 100us, then $\overline{\text{RAS}}$ precharge time must use tRPS instead of tRP.
21. For $\overline{\text{RAS}}$ -only refresh and burst $\overline{\text{CAS}}$ -before- $\overline{\text{RAS}}$ refresh mode, 4096(4K)/1024(1K) cycles of burst refresh must be executed within 64ms/16ms before and after self refresh, in order to meet refresh specification.
22. For distributed $\overline{\text{CAS}}$ -before- $\overline{\text{RAS}}$ with 15.6us interval, $\overline{\text{CAS}}$ -before- $\overline{\text{RAS}}$ refresh should be executed with in 15.6us immediately before and after self refresh in order to meet refresh specification.

WORD READ CYCLE

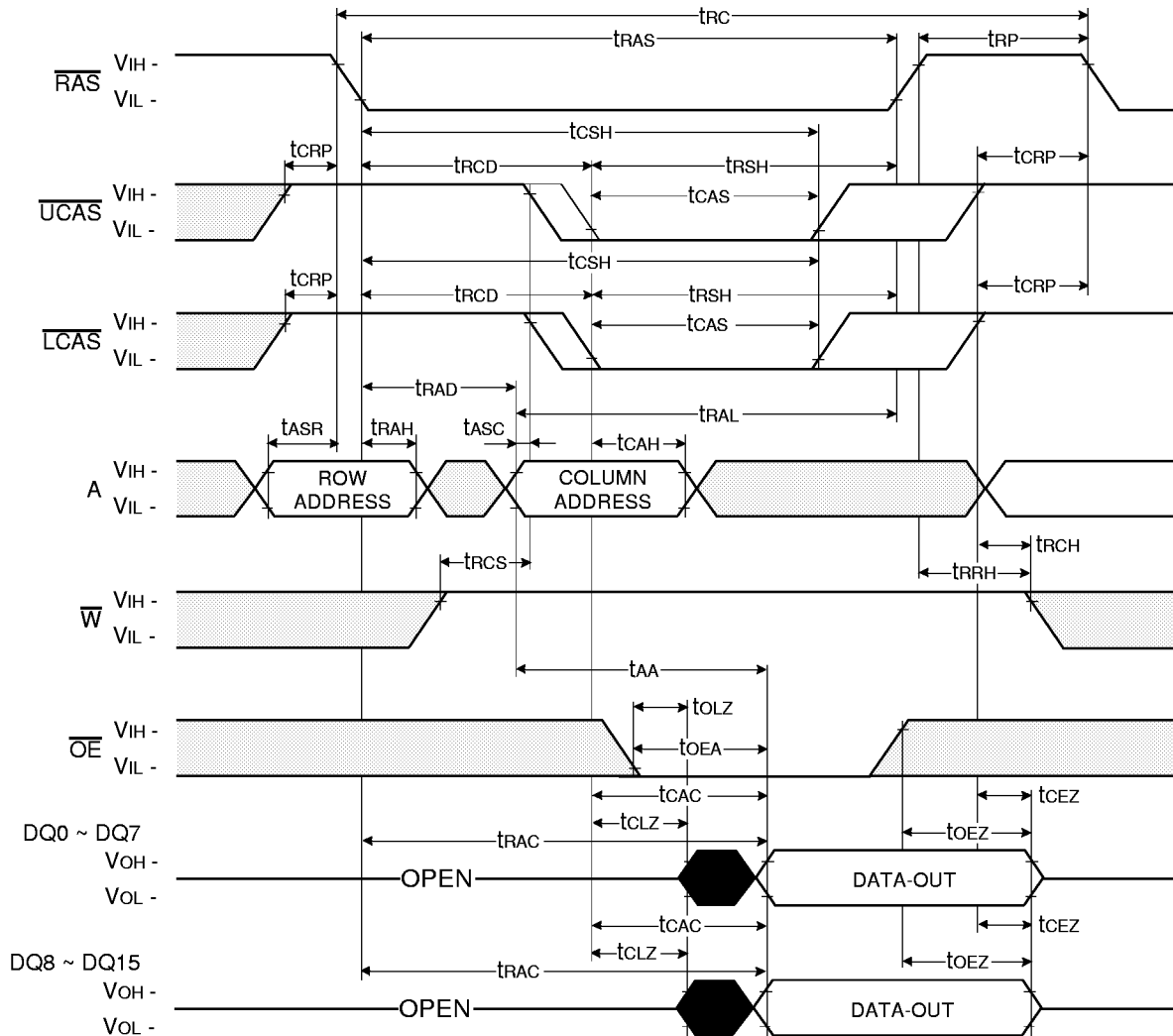

 Don't care
 Undefined

UPPER BYTE READ CYCLE

NOTE : DIN = OPEN

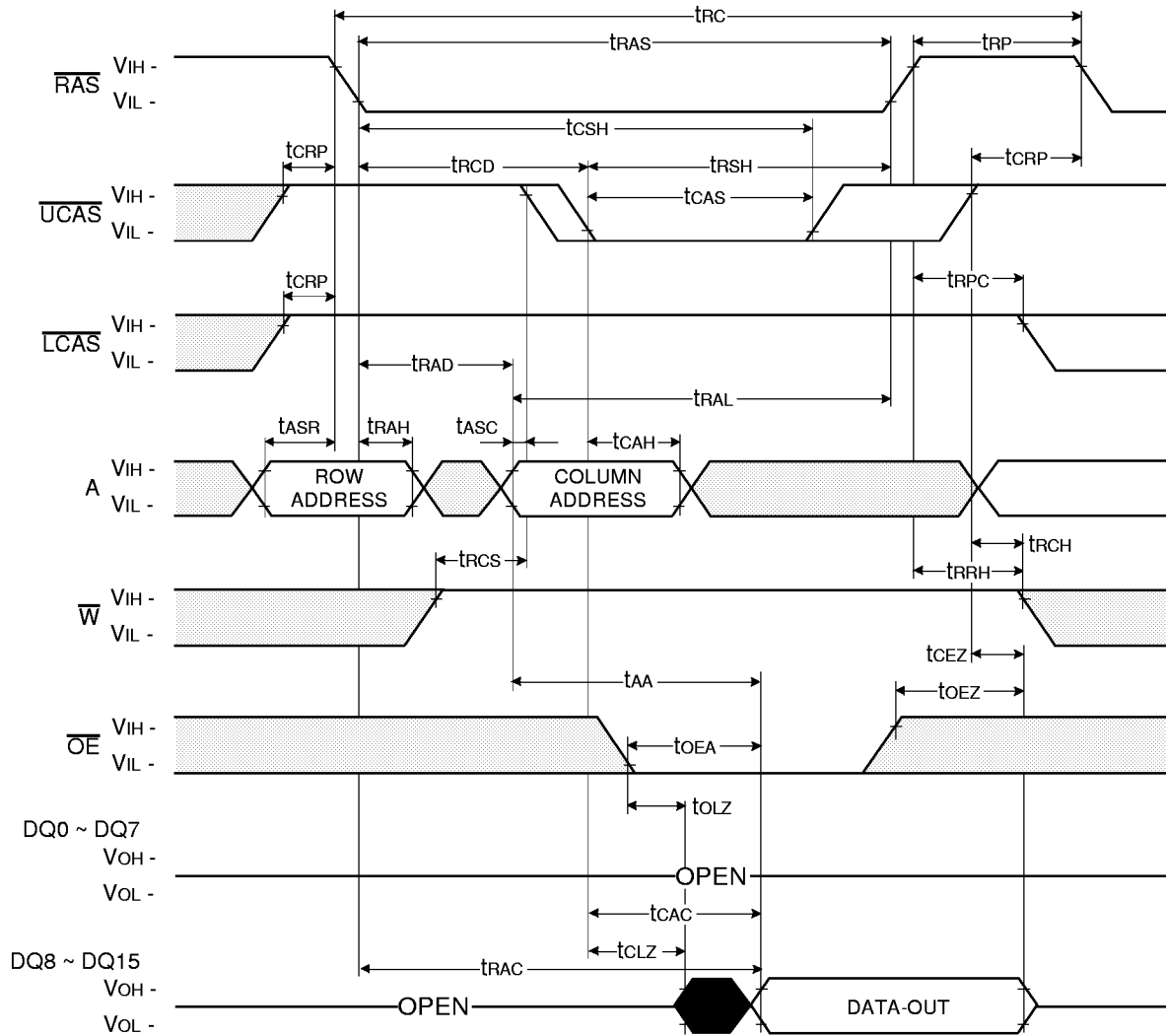

□ Don't care
■ Undefined

WORD WRITE CYCLE (EARLY WRITE)

NOTE : Dout = OPEN

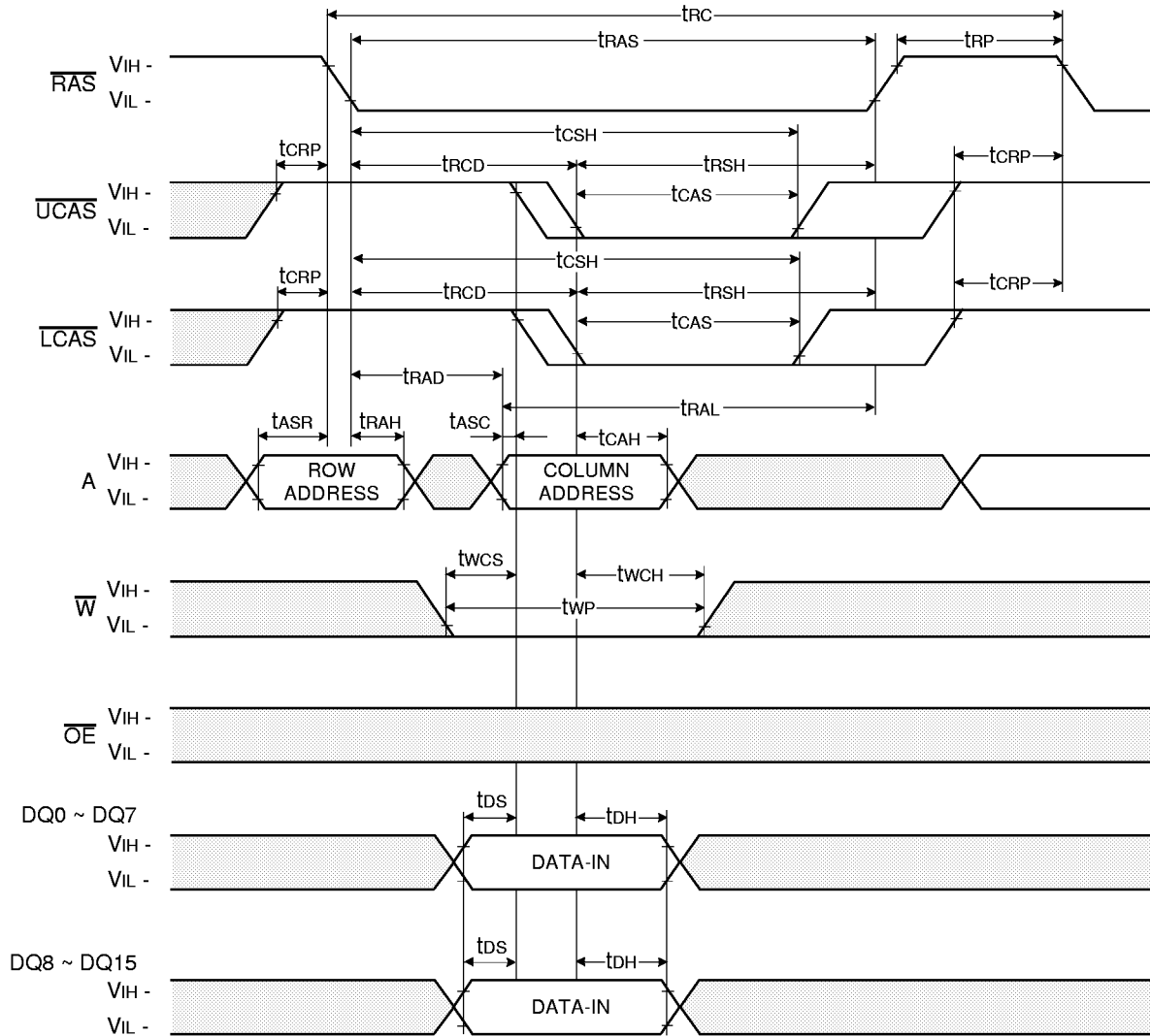

□ Don't care
■ Undefined

LOWER BYTE WRITE CYCLE (EARLY WRITE)

NOTE : DOUT = OPEN

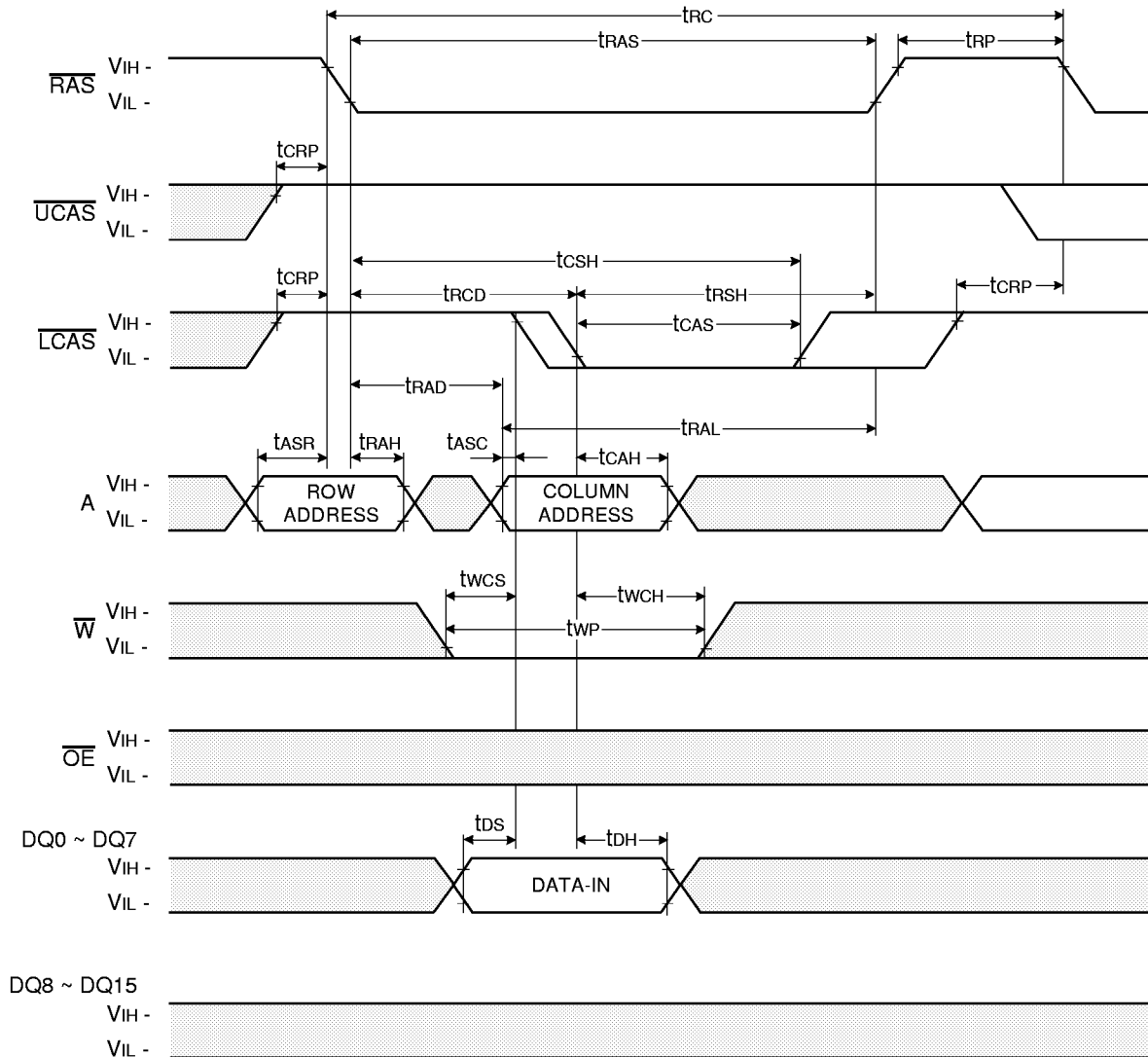

□ Don't care
■ Undefined

UPPER BYTE WRITE CYCLE (EARLY WRITE)

NOTE : DOUT = OPEN

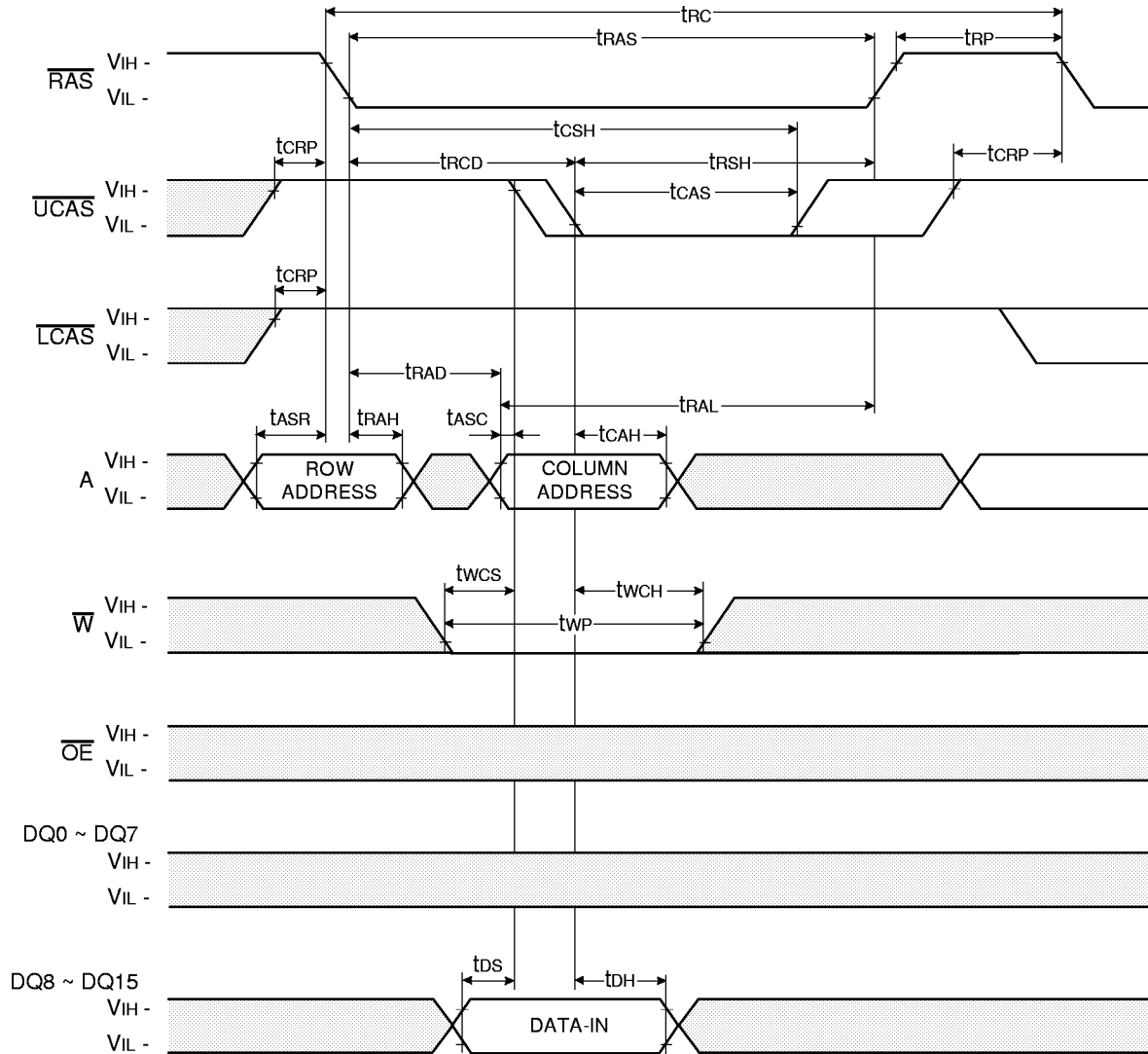

Don't care
 Undefined

WORD WRITE CYCLE (\overline{OE} CONTROLLED WRITE)

NOTE : DOUT = OPEN

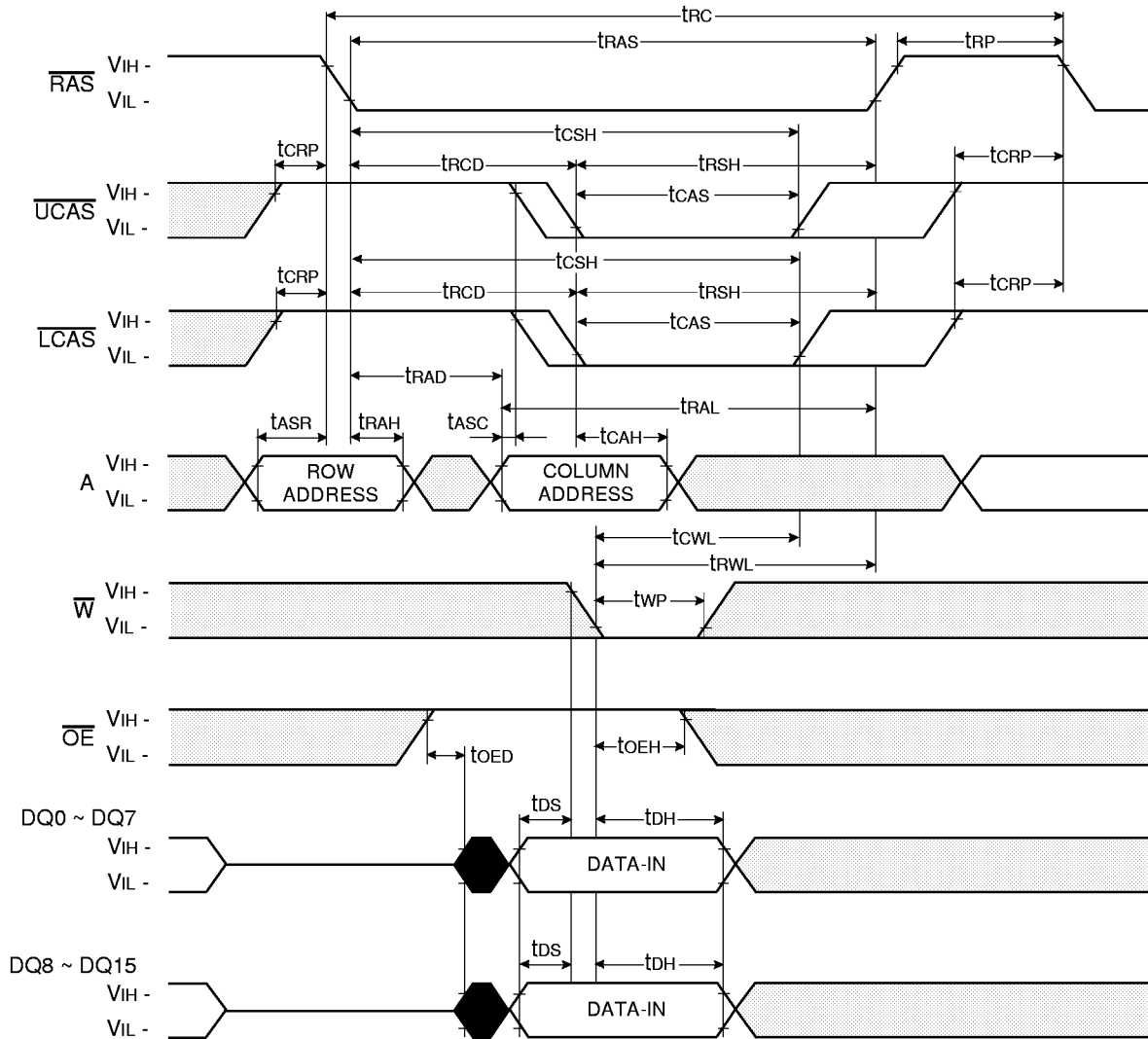

□ Don't care
 ■ Undefined

LOWER BYTE WRITE CYCLE (\overline{OE} CONTROLLED WRITE)

NOTE : DOUT = OPEN

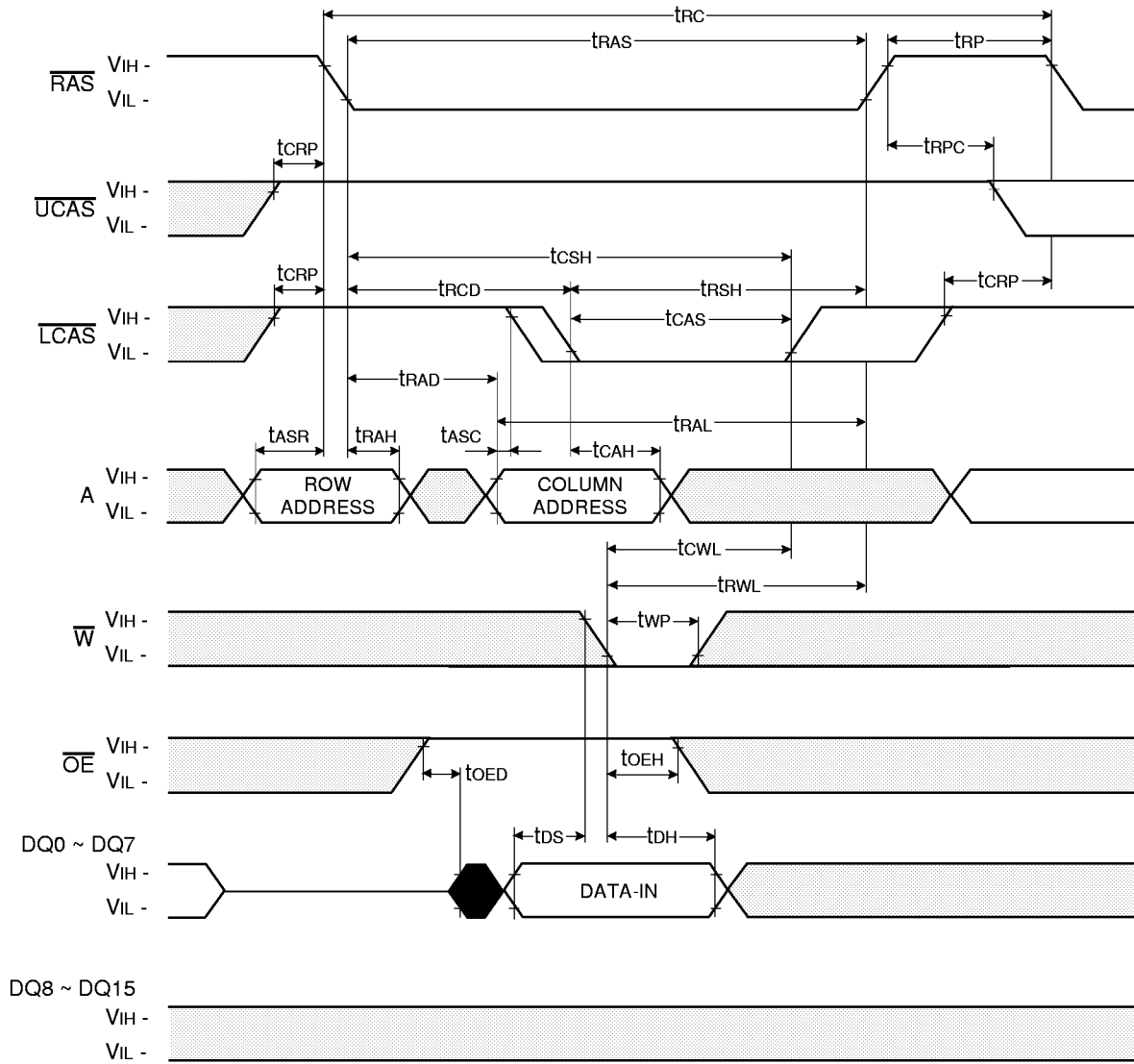

Don't care
 Undefined

UPPER BYTE WRITE CYCLE (\overline{OE} CONTROLLED WRITE)

NOTE : DOUT = OPEN

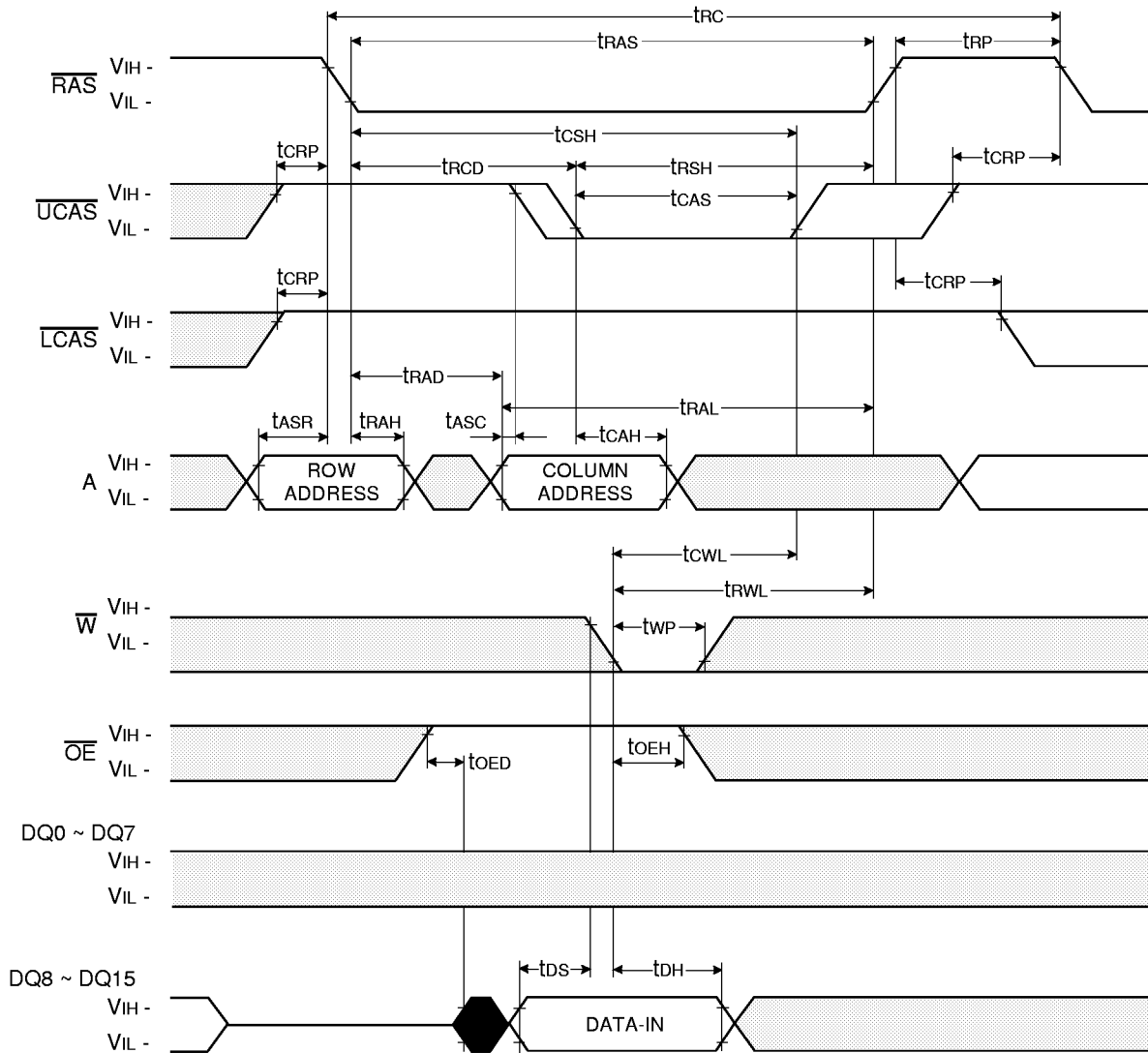

Don't care
 Undefined

**KM416C1004C, KM416C1204C
KM416V1004C, KM416V1204C**

CMOS DRAM

WORD READ - MODIFY - WRITE CYCLE

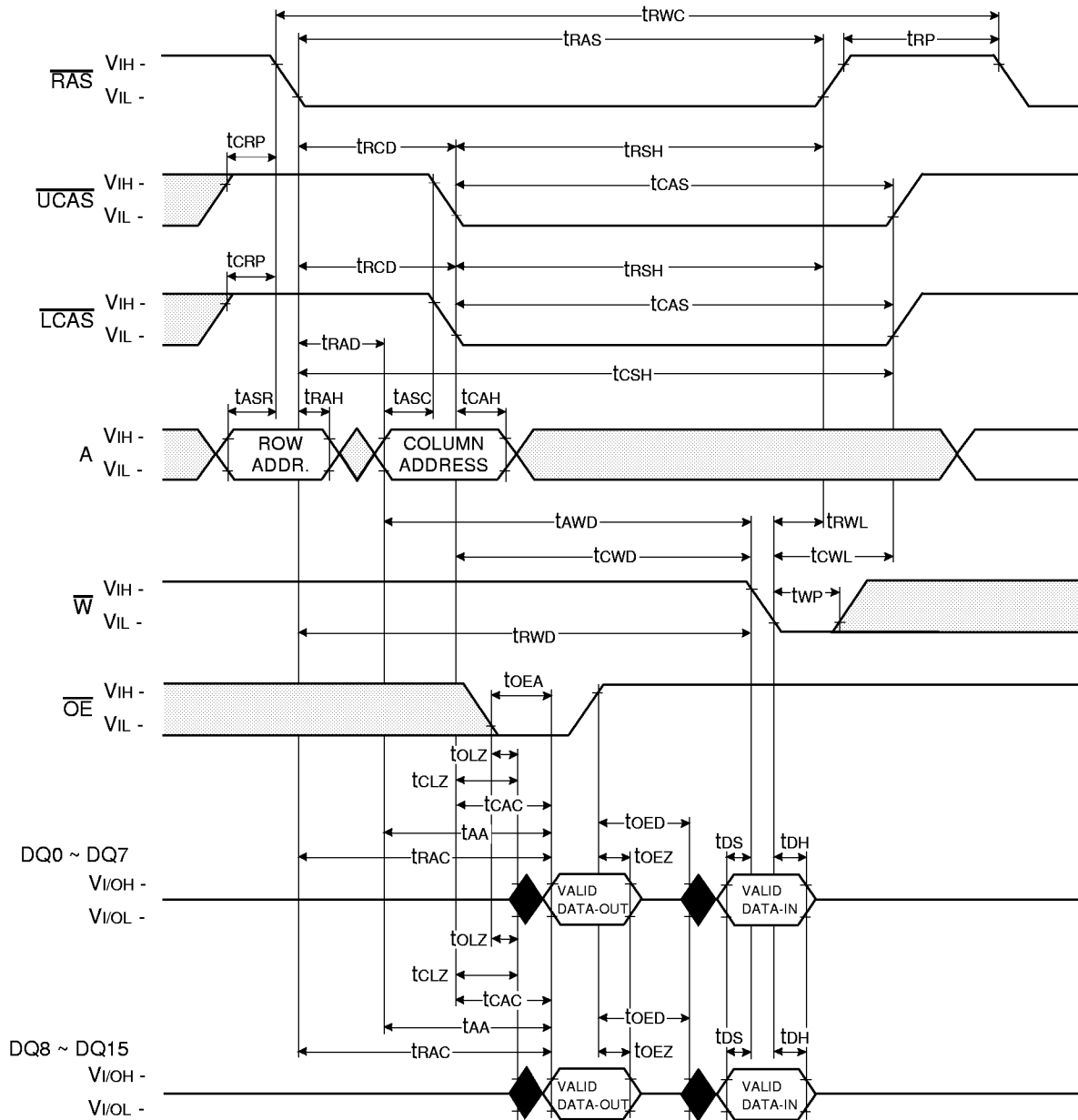

□ Don't care
■ Undefined

**KM416C1004C, KM416C1204C
KM416V1004C, KM416V1204C**

CMOS DRAM

UPPER-BYTE READ - MODIFY - WRITE CYCLE

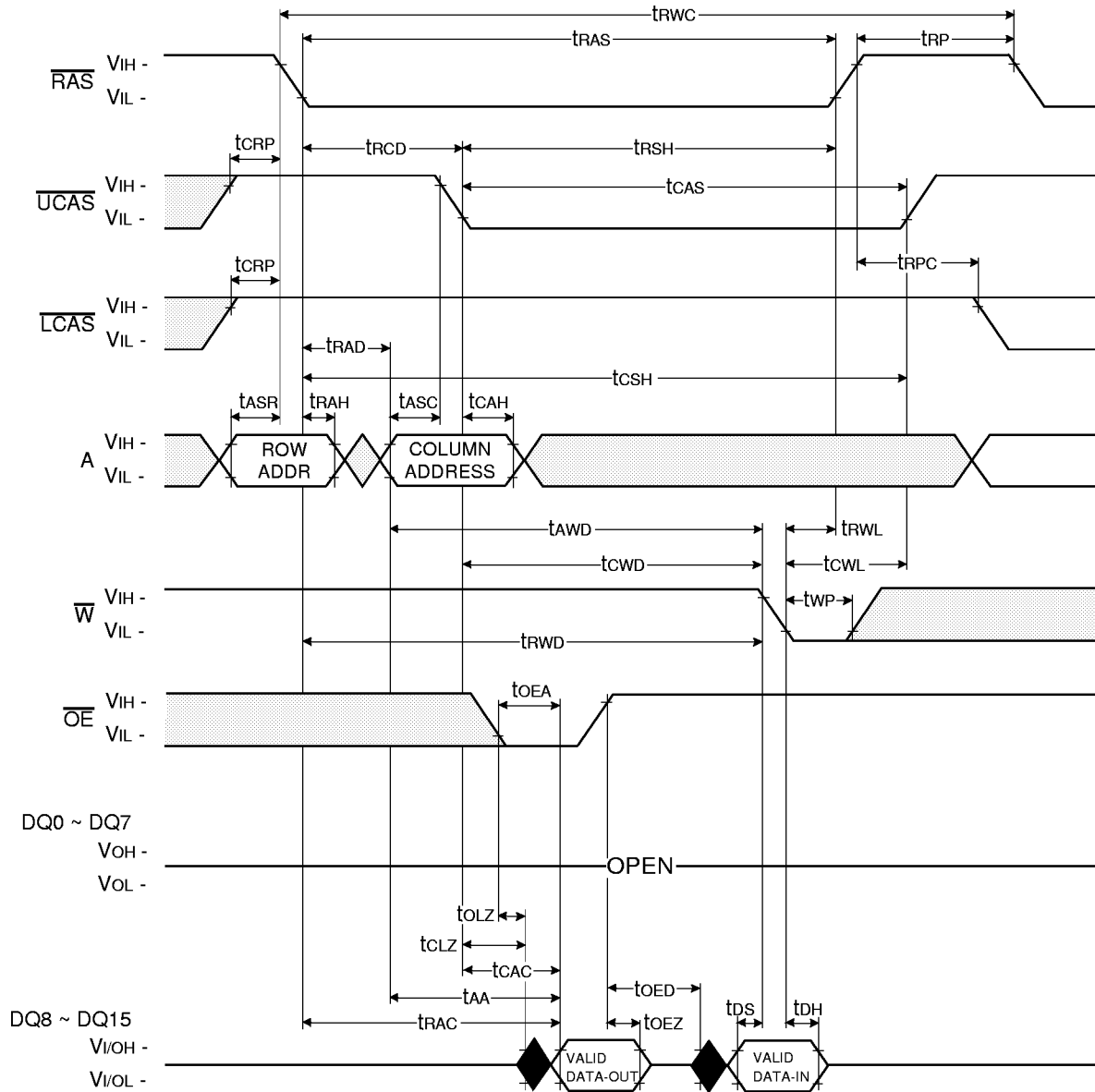

□ Don't care
■ Undefined

HYPER PAGE MODE LOWER BYTE READ CYCLE

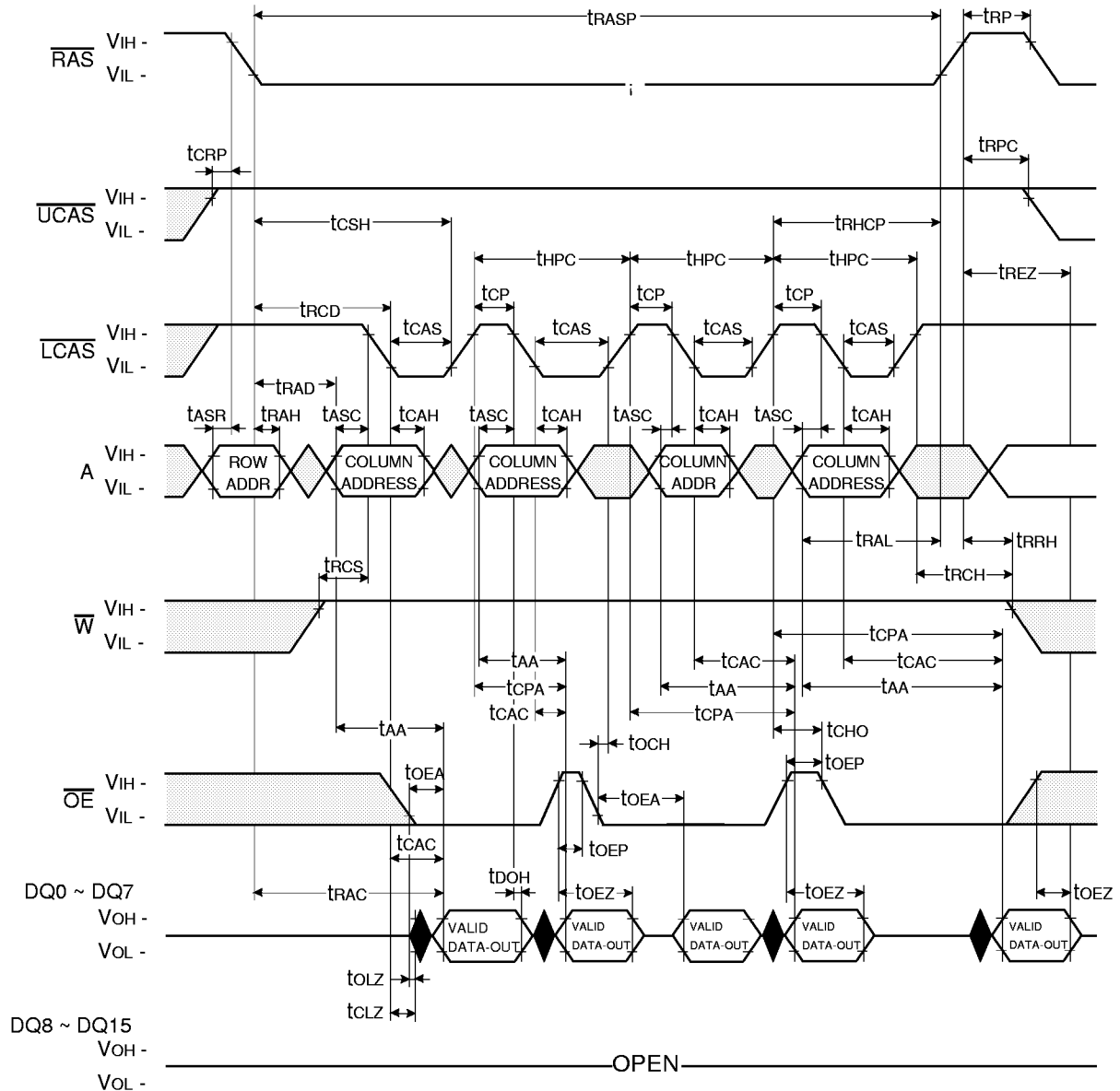

HYPER PAGE MODE WORD WRITE CYCLE (EARLY WRITE)

NOTE : Dout = OPEN

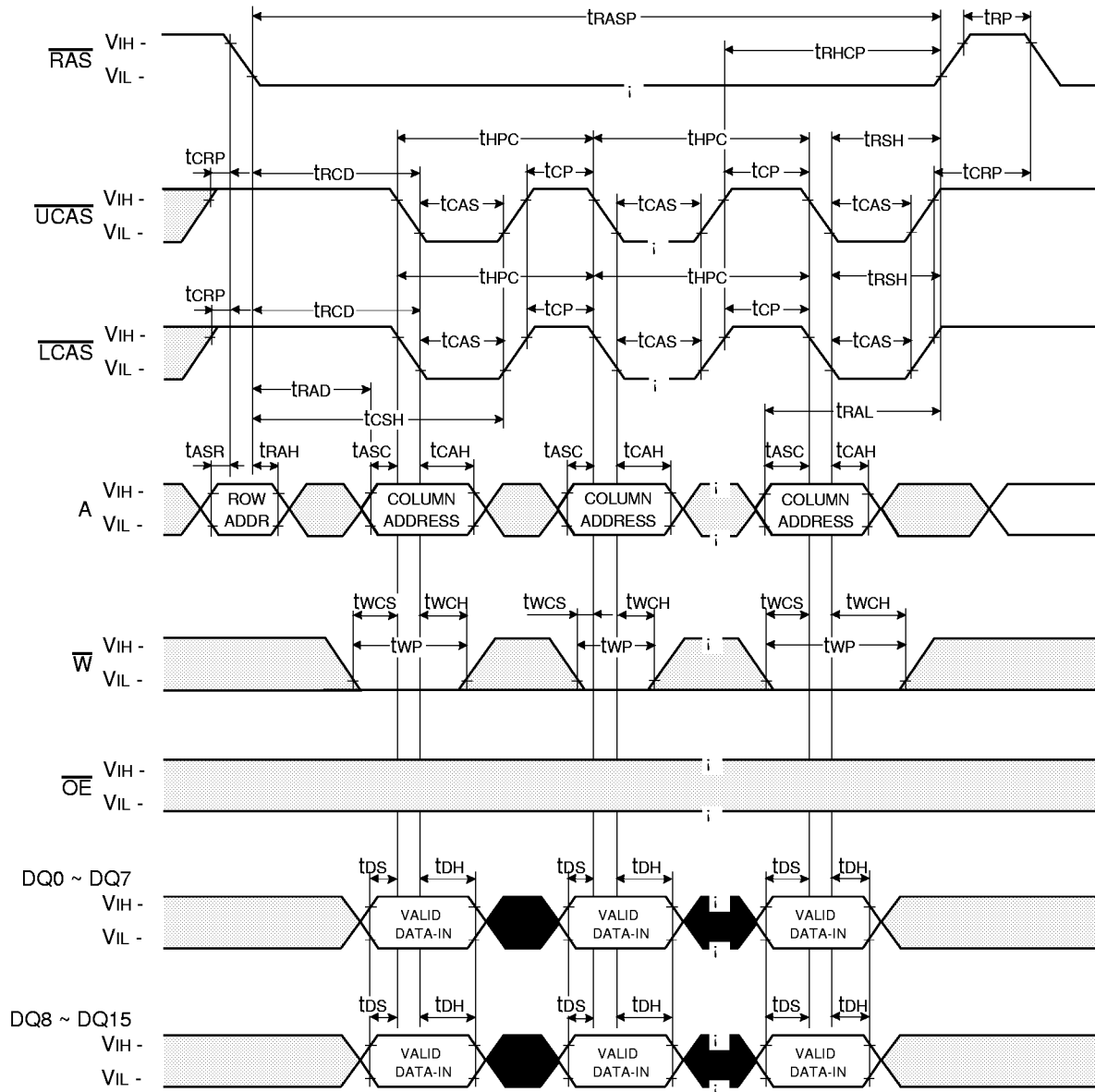

□ Don't care
■ Undefined

HYPER PAGE MODE LOWER BYTE WRITE CYCLE (EARLY WRITE)

NOTE : DOUT = OPEN

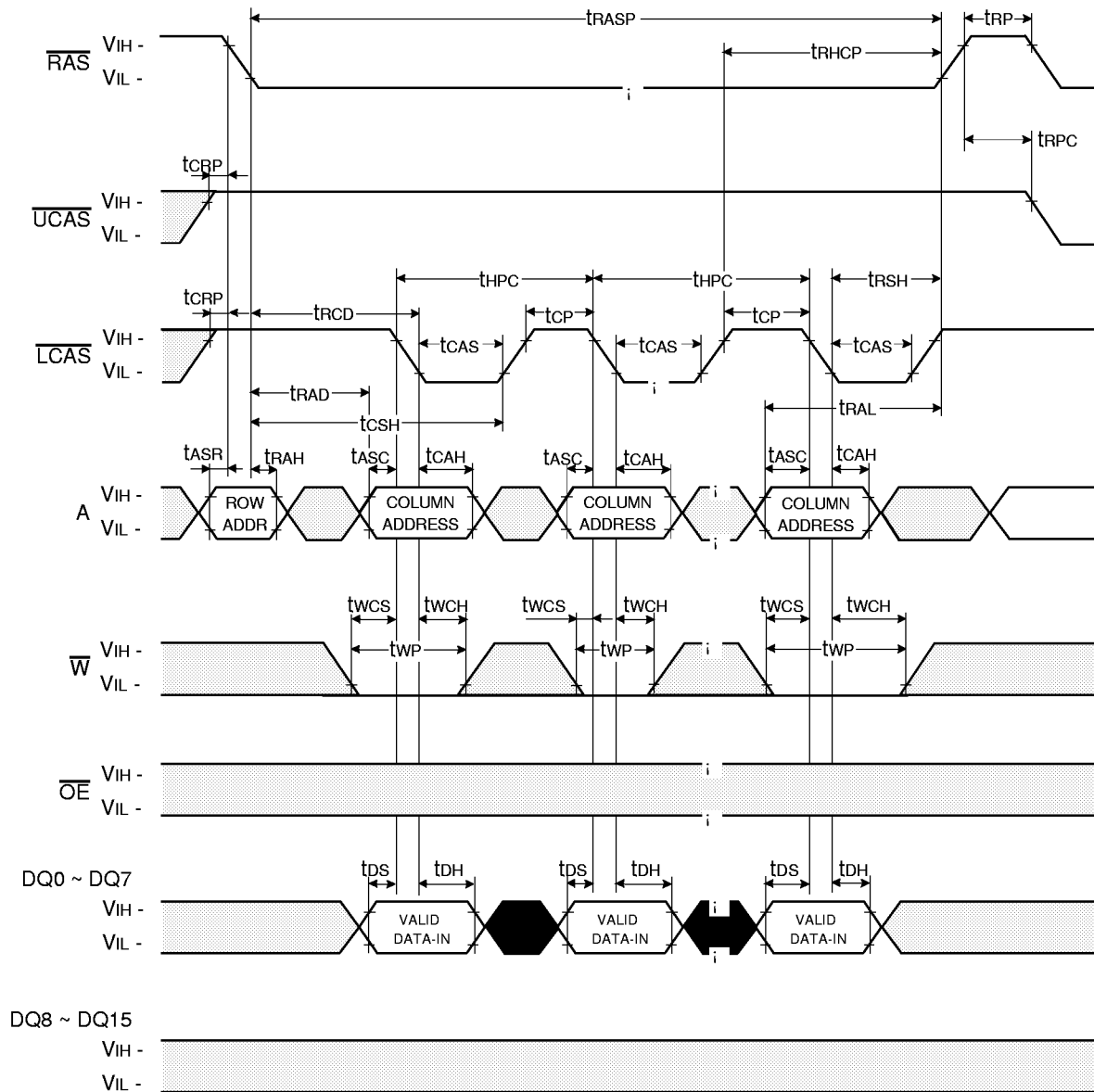

□ Don't care
■ Undefined

HYPER PAGE MODE UPPER BYTE WRITE CYCLE (EARLY WRITE)

NOTE : Dout = OPEN

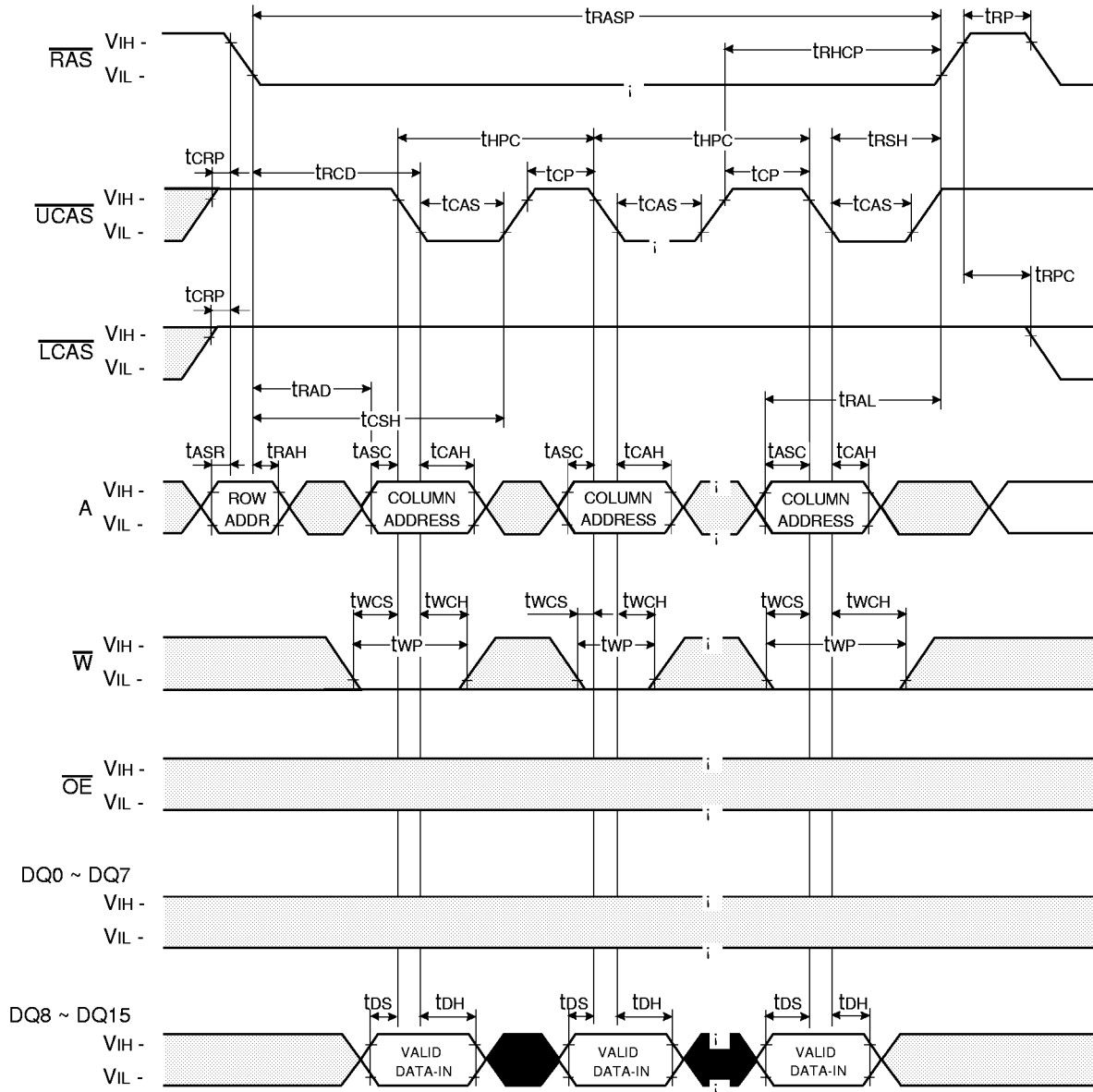

□ Don't care
■ Undefined

HYPER PAGE MODE WORD READ - MODIFY - WRITE CYCLE

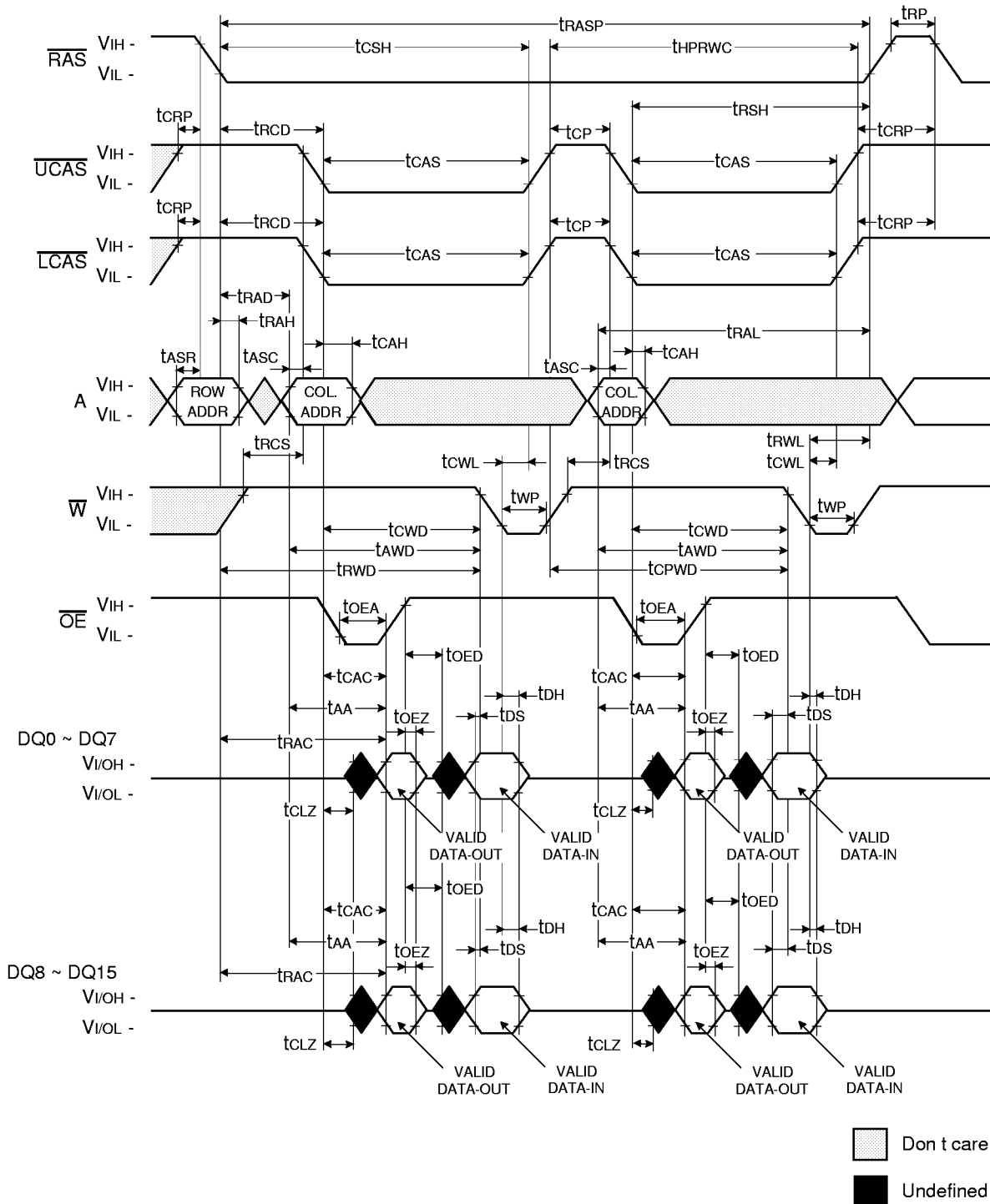

HYPER PAGE MODE LOWER BYTE READ - MODIFY - WRITE CYCLE

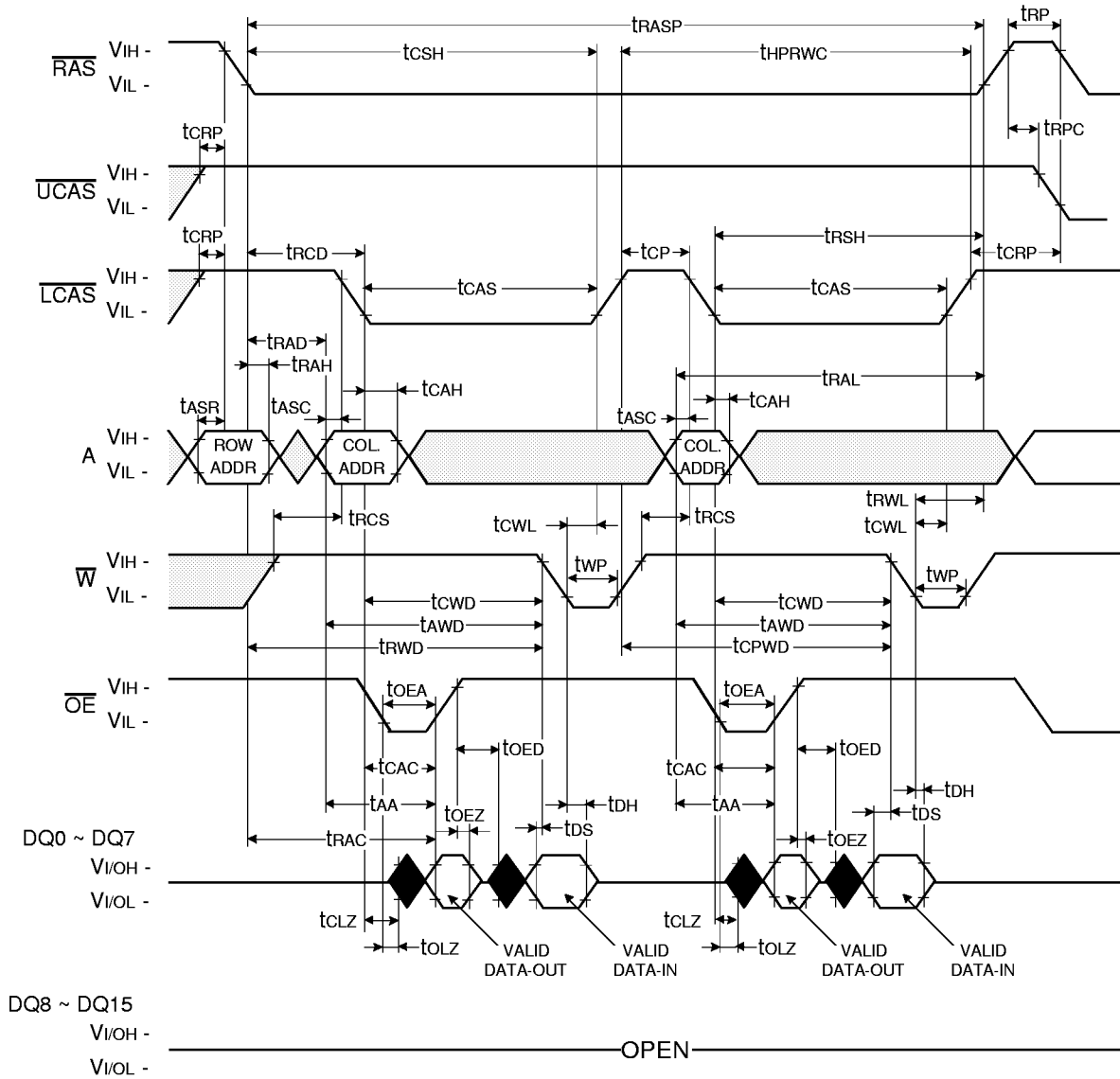

 Don't care
 Undefined

HYPER PAGE READ AND WRITE MIXED CYCLE

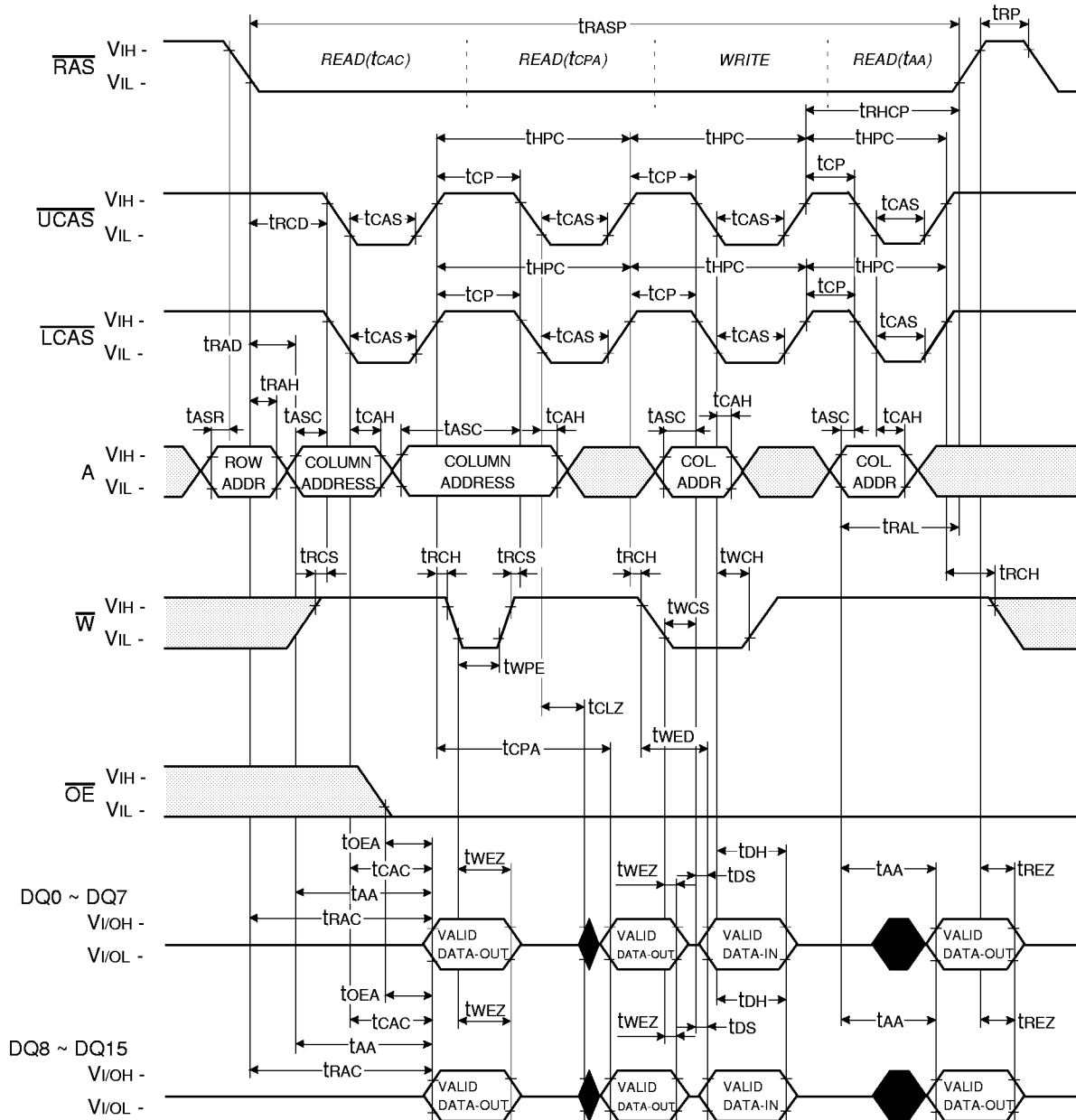

□ Don't care

■ Undefined

$\overline{\text{RAS}}$ - ONLY REFRESH CYCLE

NOTE : $\overline{\text{W}}$, $\overline{\text{OE}}$, DIN = Don't care

DOUT = OPEN

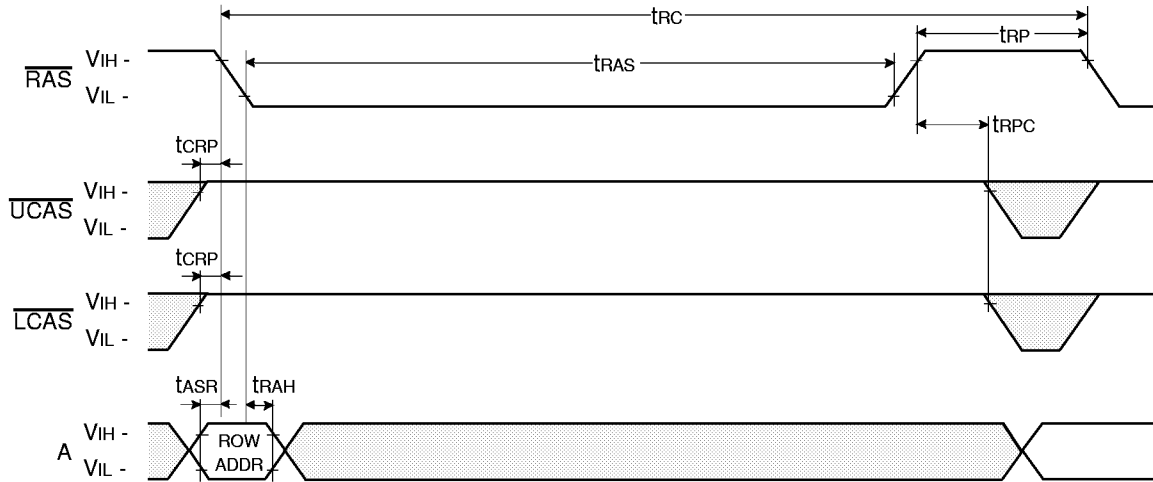

$\overline{\text{CAS}}$ - BEFORE - $\overline{\text{RAS}}$ REFRESH CYCLE

NOTE : $\overline{\text{OE}}$, A = Don't care

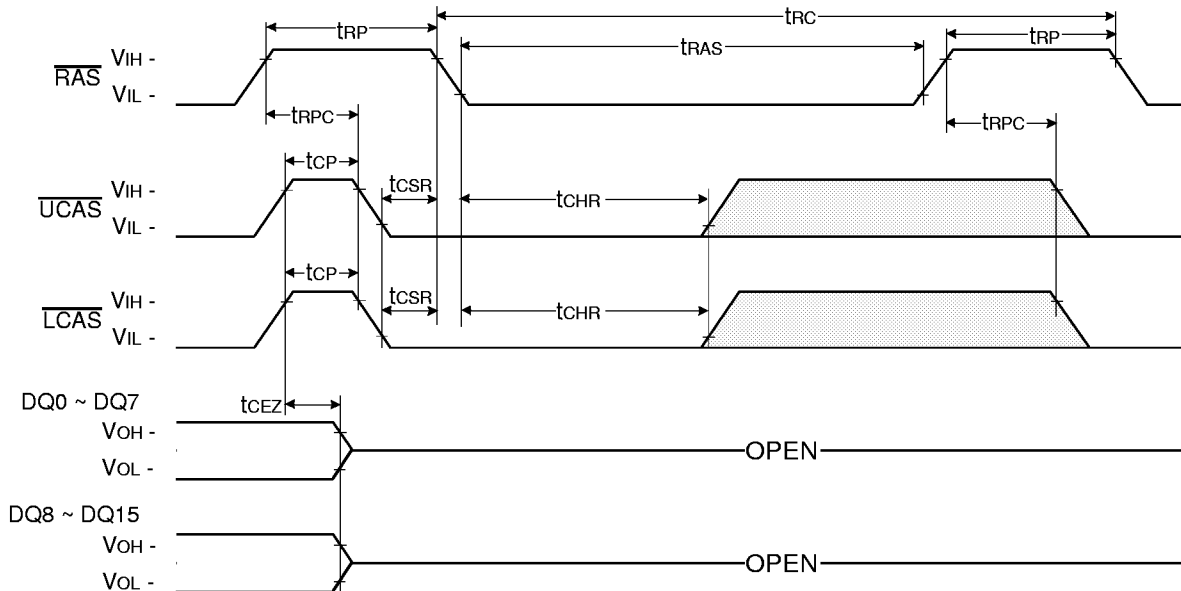

 Don't care
 Undefined

HIDDEN REFRESH CYCLE (READ)

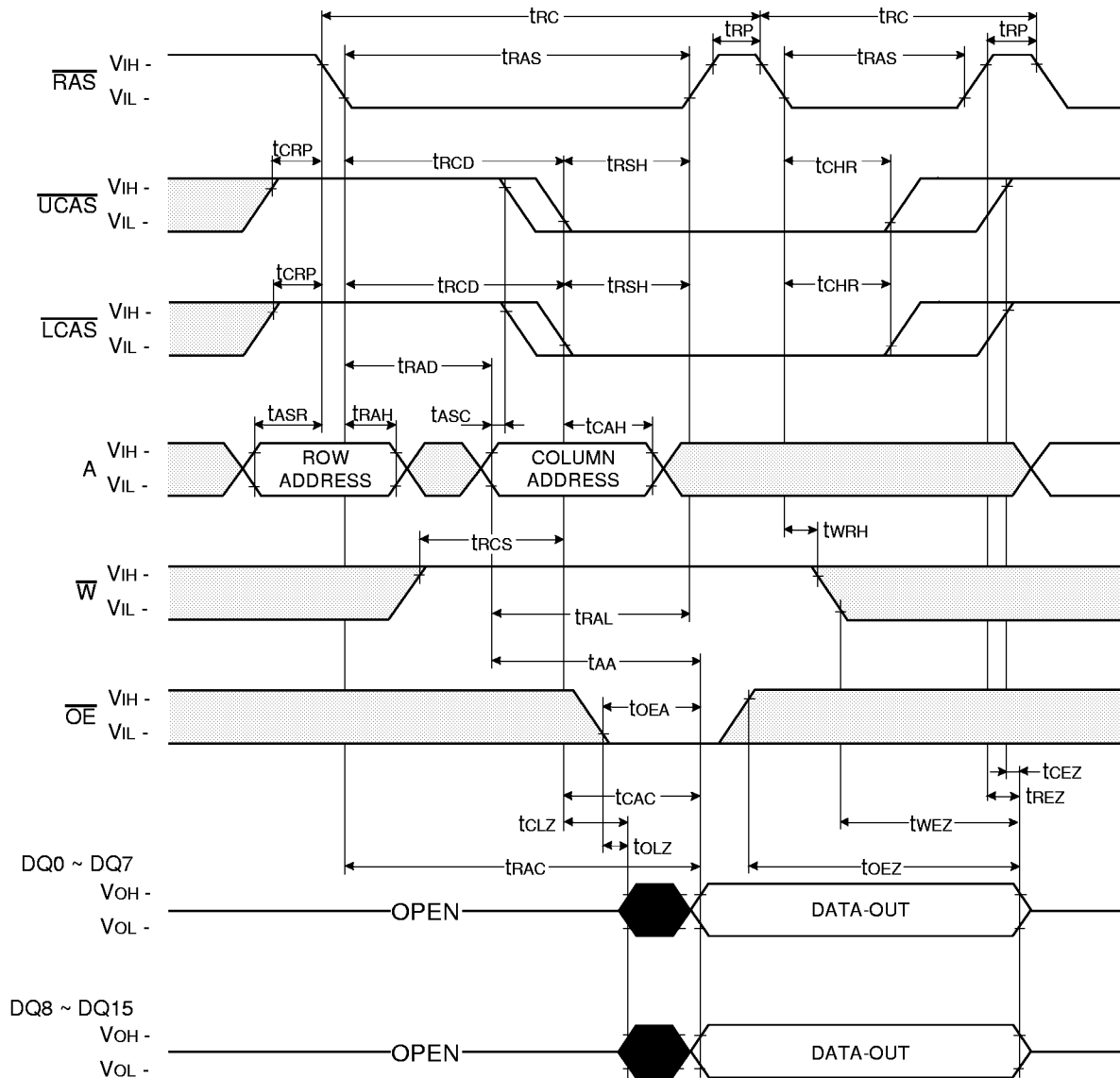

 Don't care
 Undefined

HIDDEN REFRESH CYCLE (WRITE)

NOTE : DOUT = OPEN

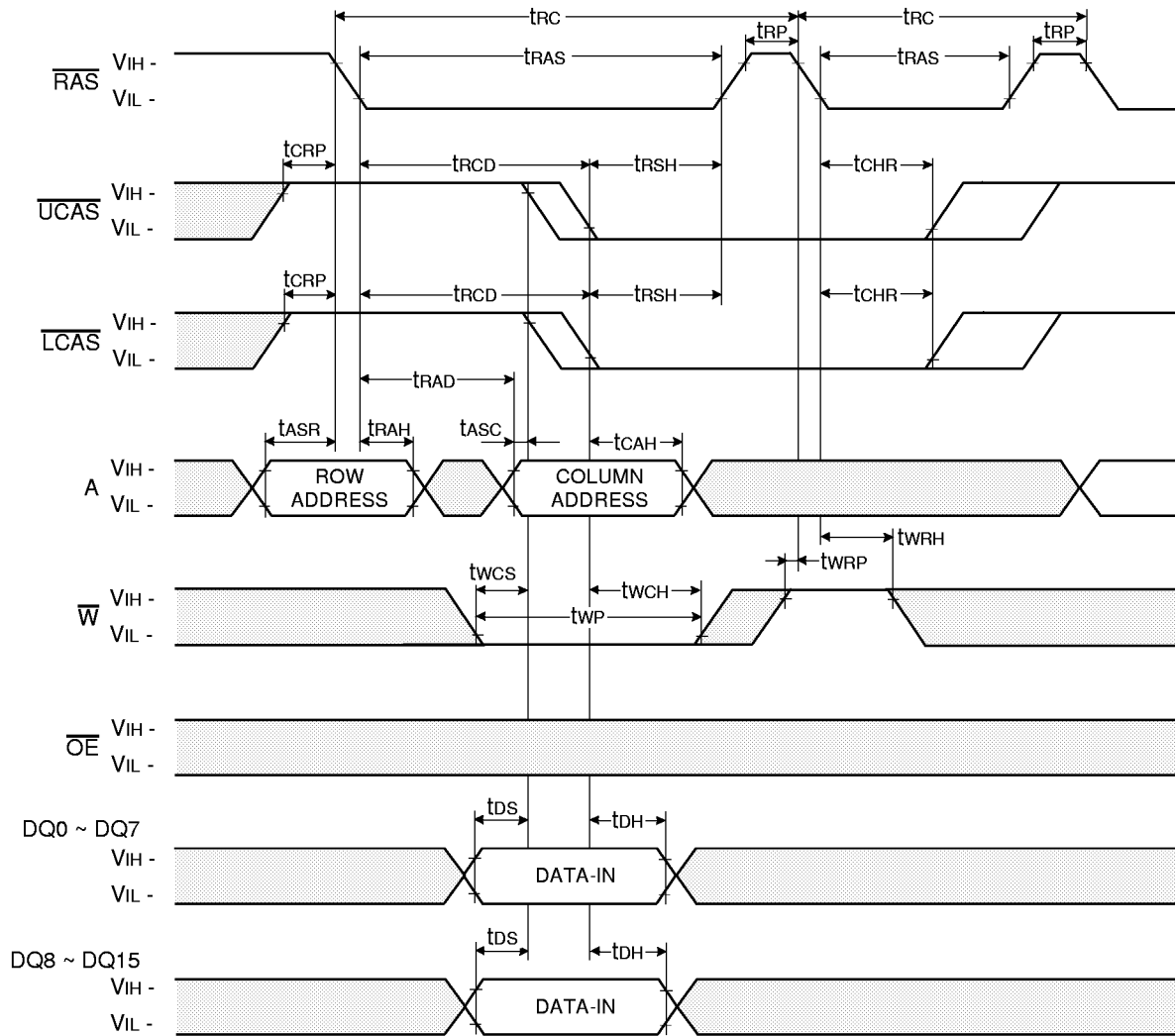

□ Don't care
■ Undefined

**KM416C1004C, KM416C1204C
KM416V1004C, KM416V1204C**

CMOS DRAM

$\overline{\text{CAS}}$ - BEFORE - $\overline{\text{RAS}}$ SELF REFRESH CYCLE

NOTE : $\overline{\text{OE}}$, A = Don't care

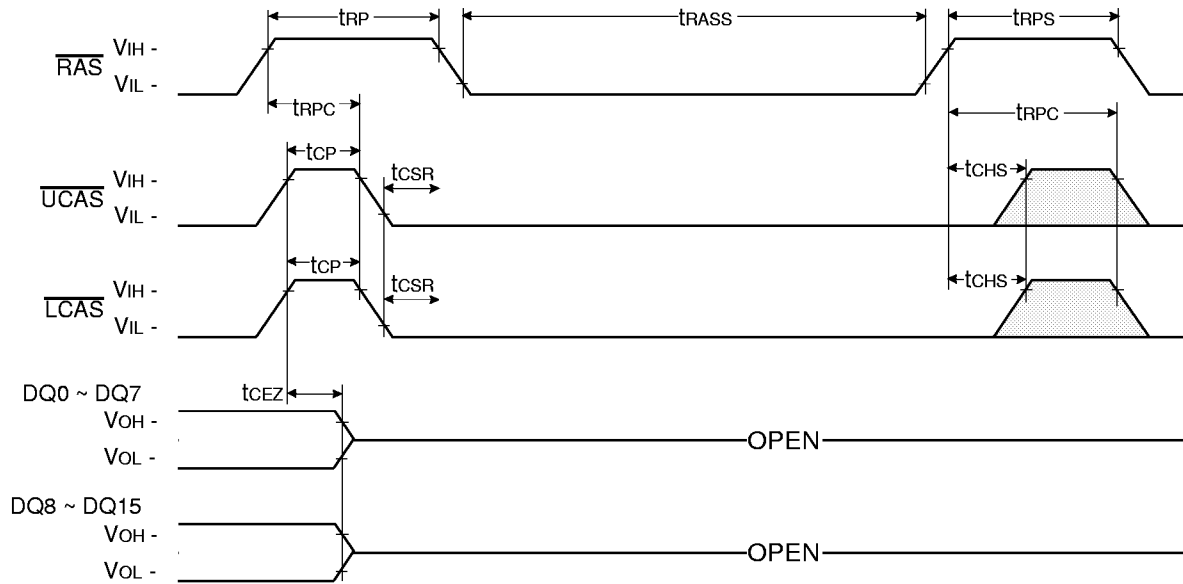

 Don't care
 Undefined



ELECTRONICS

**KM416C1004C, KM416C1204C
KM416V1004C, KM416V1204C**

CMOS DRAM

PACKAGE DIMENSION

