

Verpackt im Gurt in Anlehnung an DIN IEC 60286-3
 Tape on Reel Packaging according to DIN IEC 60286-3
 Verpackungseinheit: 280 Stück
 Packaging unit: 280 pcs

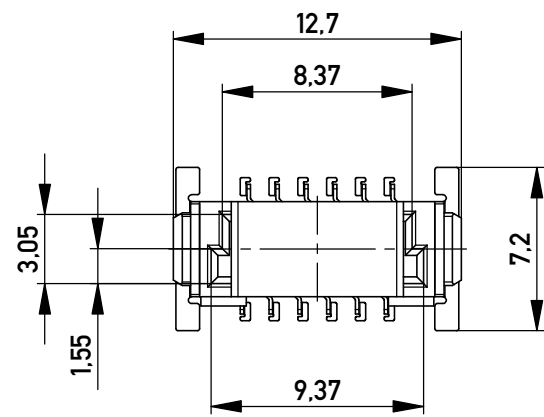

ohne Ansaughaube - without hood

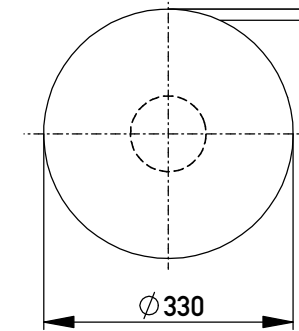
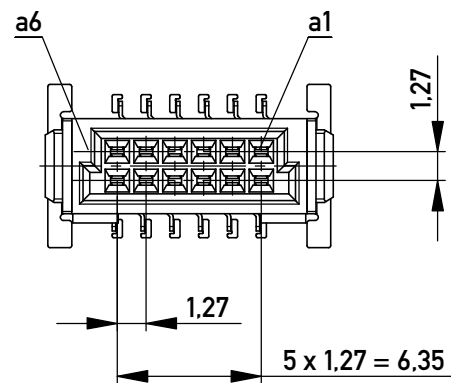

Abspulrichtung - Reel off Direction

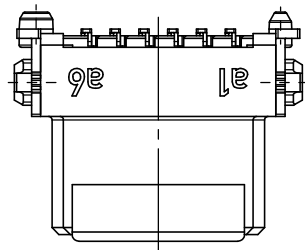
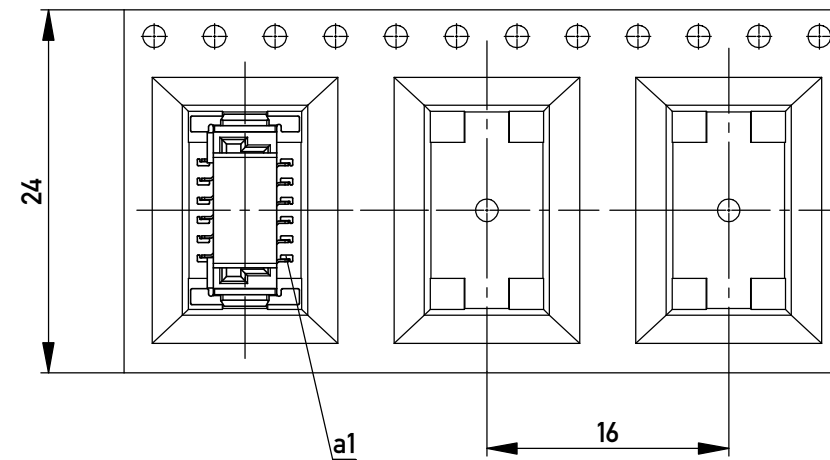

Anforderungsstufe 1
 Performance Level 1

Kontaktbereich vergoldet
 Mating Area gold plating

Anschlussbereich verzinkt 4-6 µm
 Terminal Area 4-6 µm tin plating

Koplanarität der Anschlüsse ≤ 0,1 mm
 Coplanarity Area of Termination ≤ 0,1 mm

Leiterplatten-Layout Vorschlag für SMT
 PCB-Layout Proposal for SMT

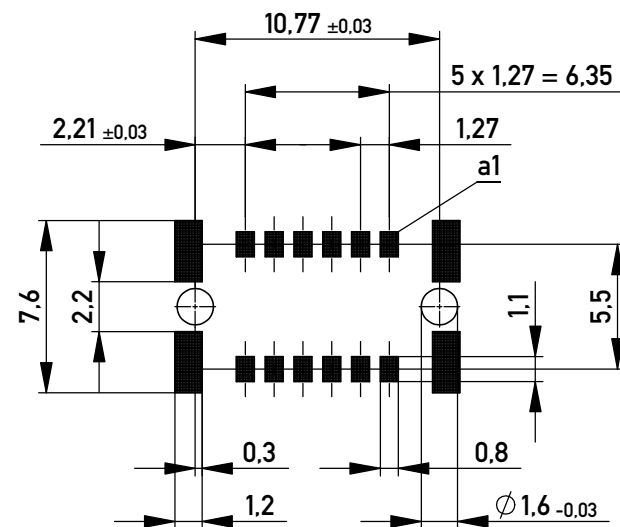

BA 7-03 - Standard Bauhöhe

type 7-03 - standard assembly height

Copyright by ERNI Production GmbH & Co. KG
 Proprietary notice pursuant to ISO 16016 to be observed.

Information:		Tolerances		Scale	3:1
All rights reserved. Only for Information. To ensure that this is the latest version of this drawing, please contact one of the ERNI companies before using.		Subject to modification without prior notice. Drawing will not be updated.		Designation	
www.ERNI.com		www.ERNI.com		Federl. SMC-B 12-SMD-BA7-03 Female SMC-B 12-SMD-type7-03	
e	16.09.2015	101603440002		K	
Index	Date	Class		A3	
		Class		SMCB	