

CMOS 8-bit Single Chip Microcomputer

Description

The CXP820P60 is a CMOS 8-bit single chip microcomputer integrating on a single chip an A/D converter, serial interface, timer/counter, time-base timer, capture timer/counter, fluorescent display panel controller/driver, remote control reception circuit, and PWM output circuit besides the basic configurations of 8-bit CPU, ROM, RAM, and I/O port.

The CXP820P60 also provides sleep/stop function that enables lower power consumption.

CXP820P60 is the PROM-incorporated version of the CXP82052/82060 with built-in mask ROM. This provides the additional feature of being able to write directly into the program. Thus, it is most suitable for evaluation use during system development and for small-quantity production.

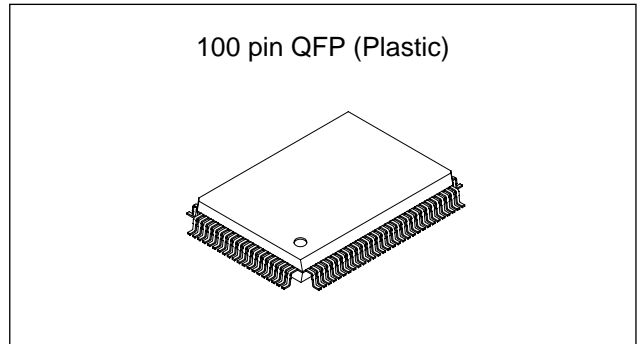

Structure

Silicon gate CMOS IC

Features

- Wide-range instruction system (213 instructions) to cover various types of data
 - 16-bit arithmetic/multiplication and division/Boolean bit operation instructions
- Minimum instruction cycle
 - 250ns at 16MHz operation
 - 122µs at 32kHz operation
- Incorporated PROM capacity
 - 60K bytes
- Incorporated RAM capacity
 - 3984 bytes (including fluorescent display area)
- Peripheral functions
 - A/D converter
 - 8 bits, 8 channels, successive approximation method (Conversion time of 3.25µs/16MHz)
 - Serial interface
 - Incorporated buffer RAM (Auto transfer for 1 to 32 bytes), 1 channel 8-bit clock synchronized type, (MSB/LSB first selectable), 1 channel Start-stop synchronization (UART), 1 channel
 - Timer
 - 8-bit timer, 8-bit timer/counter, 19-bit time-base timer
 - 16-bit capture timer/counter, 32kHz timer/counter
 - Fluorescent display panel controller/driver
 - Supports the universal grid fluorescent display panel
 - High voltage drive output port of 56 pins (40V)
 - Maximum of 640 segments display possible
 - Display timing number of 1 to 20
 - Dimmer function
 - Incorporated pull-down resistor (mask option)
 - Hardware key scan function (Maximum of 16 × 8 key matrix supportable)
- Remote control reception circuit
 - 8-bit pulse measurement counter, 6-stage FIFO
- PWM output
 - 14 bits, 1 channel
- Interruption
 - 17 factors, 15 vectors, multi-interruption possible
- Standby mode
 - Sleep/stop
- Package
 - 100-pin plastic QFP
- Piggy/Evaluation chip
 - CXP82000 100-pin ceramic QFP

Sony reserves the right to change products and specifications without prior notice. This information does not convey any license by any implication or otherwise under any patents or other right. Application circuits shown, if any, are typical examples illustrating the operation of the devices. Sony cannot assume responsibility for any problems arising out of the use of these circuits.

Block Diagram

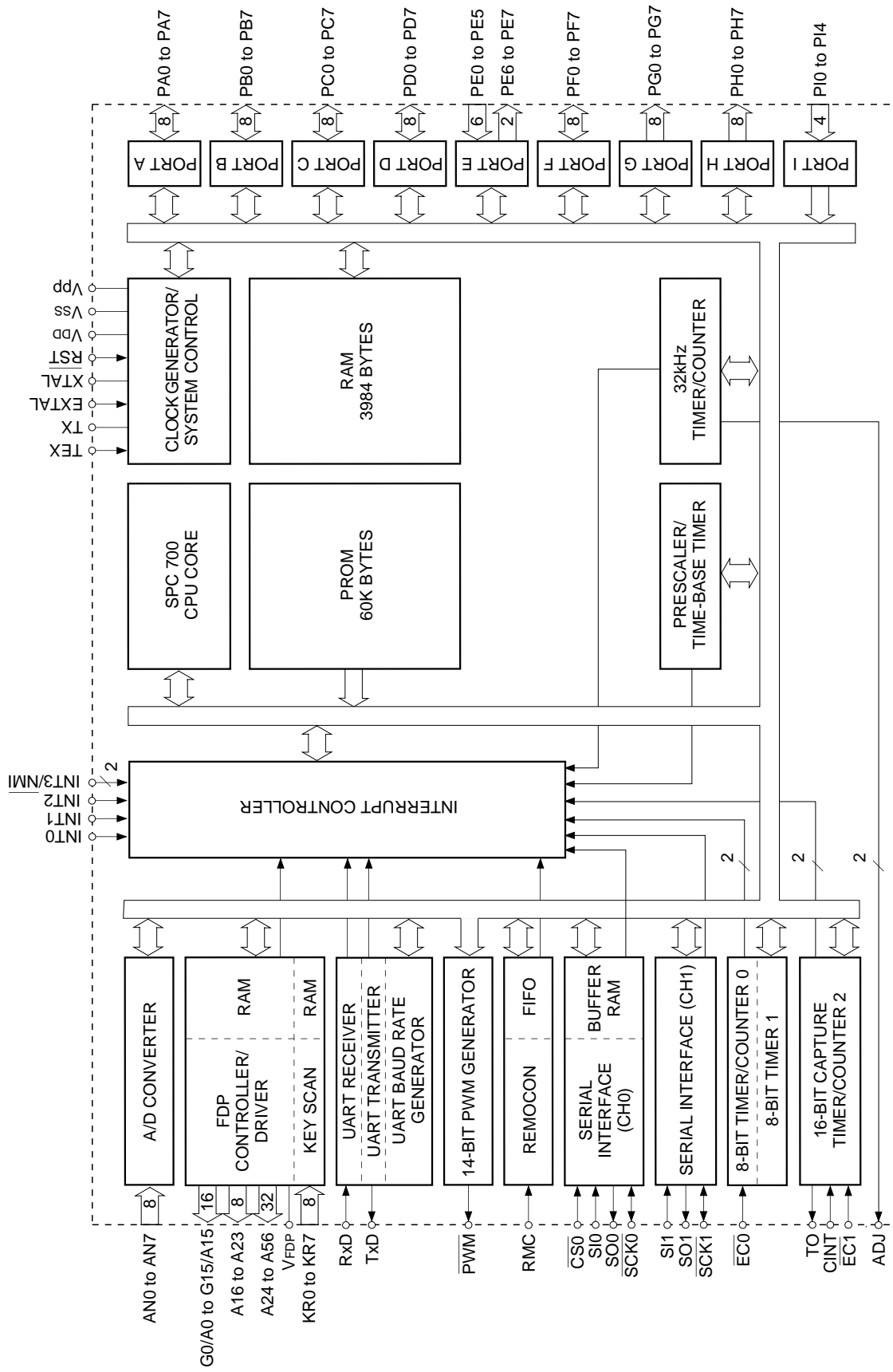

Pin Assignment (Top View)

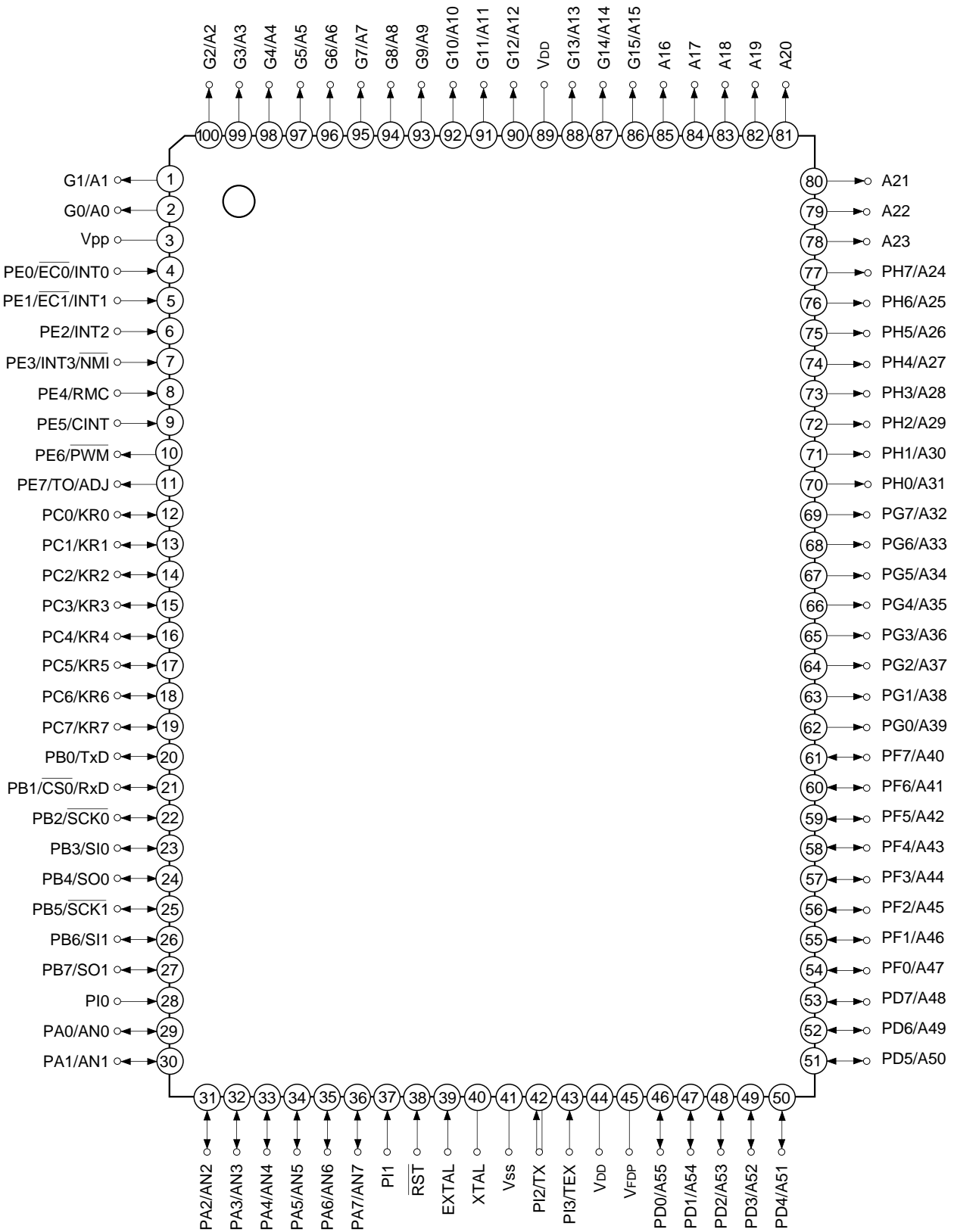

- Note)** 1. Vpp (Pin 3) is left open.
 2. VDD (Pins 44 and 89) are both connected to VDD.

Pin Description

Symbol	I/O	Functions	
PA0/AN0 to PA7/AN7	I/O/ Analog input	(Port A) 8-bit I/O port. I/O can be set in a unit of single bits. Incorporation of the pull-up resistor can be set through the program in a unit of 4 bits. (8 pins)	Analog inputs to A/D converter. (8 pins)
PB0/TxD	I/O/Output	(Port B) 8-bit I/O port. I/O can be set in a unit of single bits. Incorporation of the pull-up resistor can be set through the program in a unit of 4 bits. (8 pins)	UART transmission data output.
PB1/ $\overline{\text{CS0}}$ /RxD	I/O/Input/Input		Chip select input for serial interface (CH0). UART reception data input.
PB2/ $\overline{\text{SCK0}}$	I/O/I/O		Serial clock I/O (CH0).
PB3/SI0	I/O/Input		Serial data input (CH0).
PB4/SO0	I/O/Output		Serial data output (CH0).
PB5/ $\overline{\text{SCK1}}$	I/O/I/O		Serial clock I/O (CH1).
PB6/SI1	I/O/Input		Serial data input (CH1).
PB7/SO1	I/O/Output		Serial data output (CH1).
PC0/KR0 to PC7/KR7	I/O/Input	(Port C) 8-bit I/O port. I/O can be set in a unit of single bits. Capable of driving 12mA sink current. Incorporation of the pull-up resistor can be set through the program in a unit of 4 bits. (8 pins)	Serves as key return inputs when operating key scan with fluorescent display panel (FDP) segment signal. (8 pins)
PD0/A55 to PD7/A48	I/O/Output	(Port D) 8-bit I/O port. I/O can be set in a unit of single bits. (8 pins)	FDP segment signal (anode connection) outputs.
PE0/INT0/ $\overline{\text{EC0}}$	Input/Input/Input	(Port E) 8-bit port. Lower 6 bits are for inputs; upper 2 bits are for outputs. (8 pins)	Inputs for external interruption request. (4 pins)
PE1/INT1/ $\overline{\text{EC1}}$	Input/Input/Input		
PE2/INT2	Input/Input		Non-maskable interruption request input.
PE3/INT3/ NMI	Input/Input/Input		
PE4/RMC	Input/Input		Remote control reception circuit input.
PE5/CINT	Input/Input		External capture input for 16-bit timer/counter.
PE6/PWM	Output/Output		14-bit PWM output.
PE7/TO/ ADJ	Output/Output/ Output		Output for the 16-bit timer/counter rectangular waves, and 32kHz oscillation frequency division.

Symbol	I/O	Functions	
PF0/A47 to PF7/A40	I/O/Output	(Port F) 8-bit output port. I/O can be set in a unit of single bits. (8 pins)	FDP segment signal (anode connection) outputs. (8 pins)
PG0/A39 to PG7/A32	Output/Output	(Port G) 8-bit output port. (8 pins)	FDP segment signal (anode connection) outputs. (8 pins)
PH0/A31 to PH7/A24	Output/Output	(Port H) 8-bit output port. (8 pins)	FDP segment signal (anode connection) outputs. (8 pins)
PI0	Input	(Port I) 4-bit input port. (4 pins)	Crystal connectors for 32kHz timer/counter clock oscillation. For usage as event counter, input to TEX, and leave TX open.
PI1	Input		
PI2/TX	Input		
PI3/TEX	Input/Input		
A16 to A23	Output	FDP segment signal (anode connection) outputs. (8 pins)	
G0/A0 to G15/A15	Output/Output	Outputs for FDP timing signals (grid connection)/segment signals (anode connection). (16 pins)	
V _{FDP}		FDP voltage supply for incorporated pull-down (PD) resistor.	
EXTAL	Input	Crystal connectors for system clock oscillation. When the clock is supplied externally, input to EXTAL; opposite phase clock should be input to XTAL.	
XTAL			
$\overline{\text{RST}}$	Input	Low-level active, system reset.	
V _{pp}		V _{cc} supply for incorporated PROM writing. Leave this pin open during normal operation.	
V _{DD}		Positive power supply.	
V _{SS}		GND.	

I/O Circuit Format for Pins

Pin	Circuit format	After a reset
<p>PA0/AN0 to PA7/AN7</p> <p>8 pins</p>	<p>Port A</p> <p>Pull-up register "0" after a reset</p> <p>Port A data</p> <p>Port A direction "0" after a reset</p> <p>Internal data bus</p> <p>RD (Port A)</p> <p>Port A input selector "0" after a reset</p> <p>Input multiplexer</p> <p>A/D converter</p> <p>* Pull-up transistor approx. 100kΩ</p>	<p>Hi-Z</p>
<p>PB0/TxD</p> <p>1 pin</p>	<p>Port B</p> <p>Pull-up register "0" after a reset</p> <p>TxD</p> <p>UART output selection "0" after a reset</p> <p>Port B data</p> <p>Port B direction "0" after a reset</p> <p>Internal data bus</p> <p>RD (Port B)</p> <p>* Pull-up transistor approx. 100kΩ</p>	<p>Hi-Z</p>
<p>PB1/$\overline{\text{CS0}}$/RxD PB3/SI0 PB6/SI1</p> <p>3 pins</p>	<p>Port B</p> <p>Pull-up register "0" after a reset</p> <p>Port B data</p> <p>Port B direction "0" after a reset</p> <p>Internal data bus</p> <p>RD (Port B)</p> <p>Schmitt input</p> <p>$\overline{\text{CS0}}$ SI0 SI1 RxD</p> <p>* Pull-up transistor approx. 100kΩ</p>	<p>Hi-Z</p>

Pin	Circuit format	After a reset
<p>PB2/$\overline{\text{SCK0}}$ PB5/$\overline{\text{SCK1}}$</p> <p>2 pins</p>	<p>Port B</p> <p>* Pull-up transistor approx. 100kΩ</p>	<p>Hi-Z</p>
<p>PB4/$\overline{\text{SO0}}$ PB7/$\overline{\text{SO1}}$</p> <p>2 pins</p>	<p>Port B</p> <p>* Pull-up transistor approx. 100kΩ</p>	<p>Hi-Z</p>
<p>PC0/$\overline{\text{KR0}}$ to PC7/$\overline{\text{KR7}}$</p> <p>8 pins</p>	<p>Port C</p> <p>*₁ Large current 12mA *₂ Pull-up transistor approx. 100kΩ</p>	<p>Hi-Z</p>

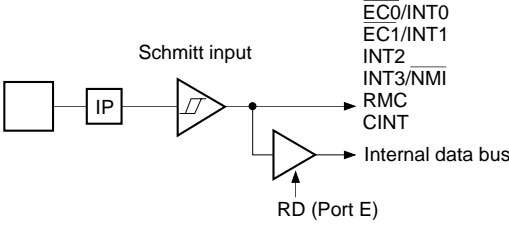
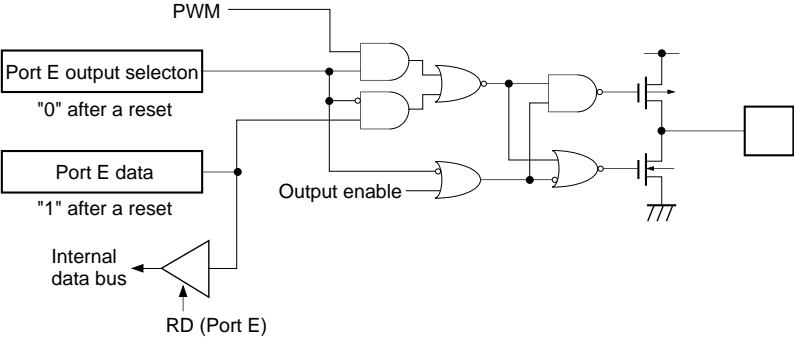
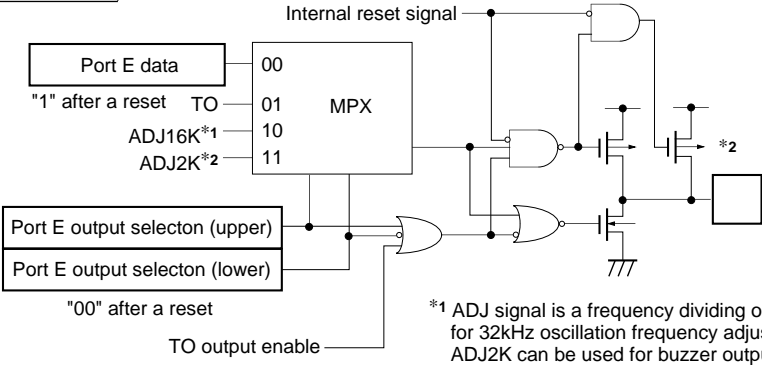
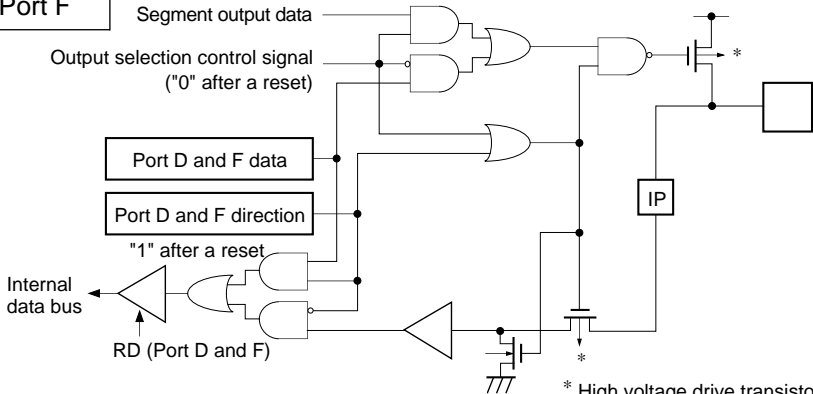
Pin	Circuit format	After a reset
<p>PE0/$\overline{EC0}$/INT0 PE1/$\overline{EC1}$/INT1 PE2/INT2 PE3/INT3/\overline{NMI} PE4/RMC PE5/CINT</p> <p>6 pins</p>	<p>Port E</p>  <p>$\overline{EC0}$/INT0 $\overline{EC1}$/INT1 INT2 INT3/\overline{NMI} RMC CINT</p> <p>Internal data bus</p> <p>RD (Port E)</p>	<p>Hi-Z</p>
<p>PE6/\overline{PWM}</p> <p>1 pin</p>	<p>Port E</p>  <p>\overline{PWM}</p> <p>Port E output selector "0" after a reset</p> <p>Port E data "1" after a reset</p> <p>Internal data bus</p> <p>RD (Port E)</p> <p>Output enable</p>	<p>High level</p>
<p>PE7/TO/ADJ</p> <p>1 pin</p>	<p>Port E</p>  <p>Internal reset signal</p> <p>Port E data "1" after a reset</p> <p>MPX</p> <p>00 TO 01 ADJ16K*1 10 ADJ2K*2 11</p> <p>Port E output selector (upper) Port E output selector (lower) "00" after a reset</p> <p>TO output enable</p> <p>*1 ADJ signal is a frequency dividing output for 32kHz oscillation frequency adjustment. ADJ2K can be used for buzzer output. *2 Pull-up transistor approx. 150kΩ</p>	<p>High level (High level at ON resistance of pull-up transistor during a reset)</p>
<p>PD0/A55 to PD7/A48 PF0/A47 to PF7/A40</p> <p>16 pins</p>	<p>Port D Port F</p>  <p>Segment output data</p> <p>Output selection control signal ("0" after a reset)</p> <p>Port D and F data</p> <p>Port D and F direction</p> <p>Internal data bus</p> <p>"1" after a reset</p> <p>RD (Port D and F)</p> <p>IP</p> <p>* High voltage drive transistor</p>	<p>Hi-Z</p>

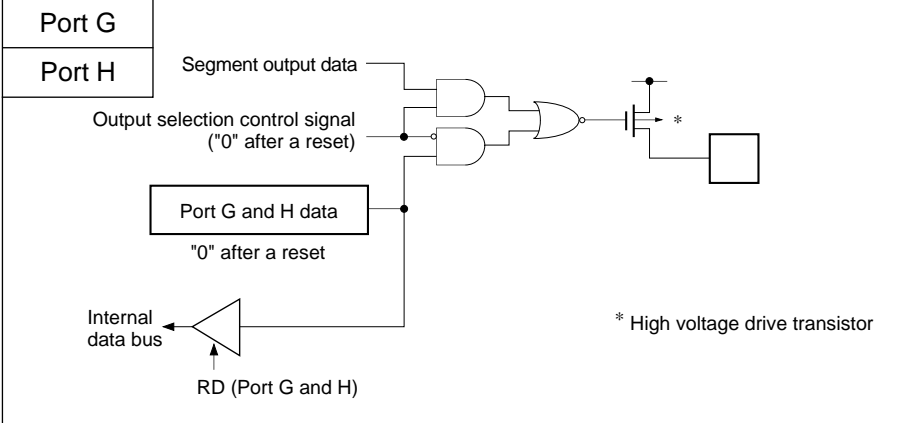
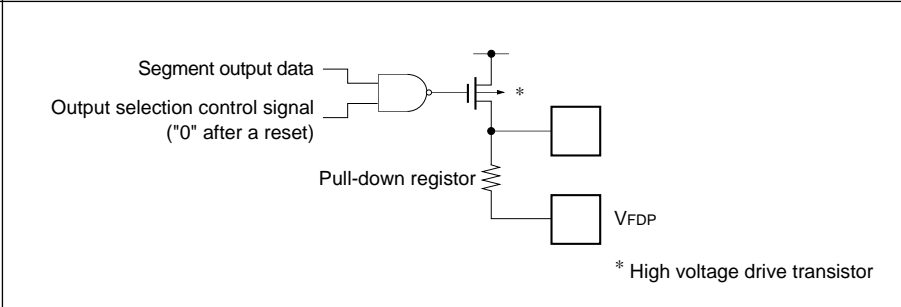
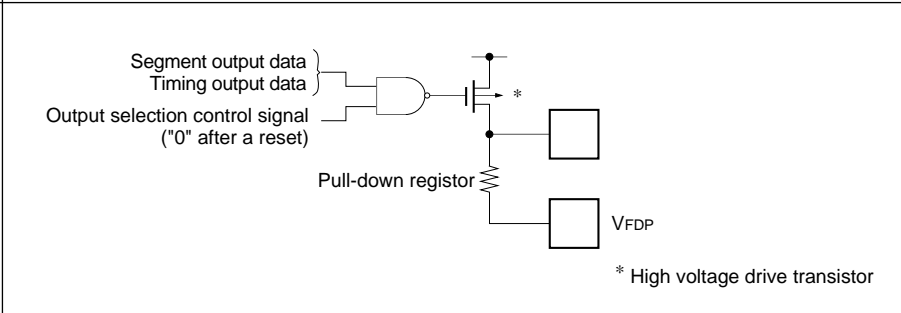
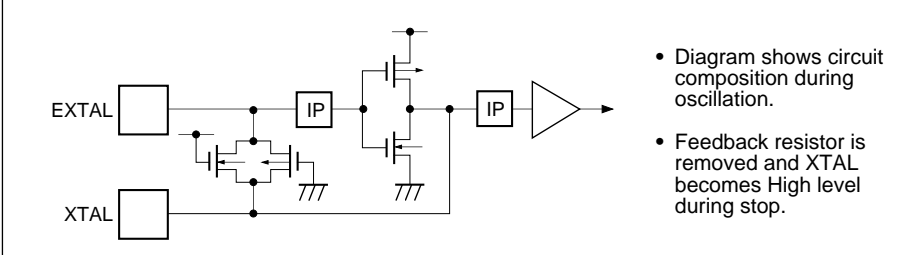
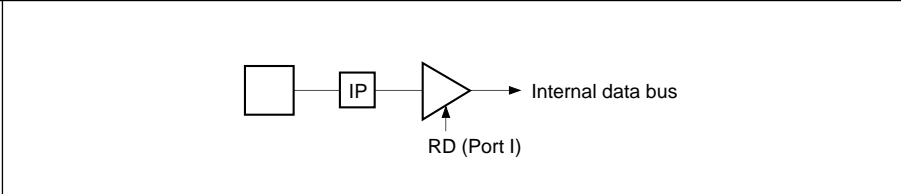
Pin	Circuit format	After a reset
PG0/A39 to PG7/A32 PH0/A31 to PH7/A24 16 pins		Hi-Z
A16 to A23 8 pins		Hi-Z or Low level (when PD resistor is connected)
G0/A0 to G15/A15 16 pins		Hi-Z or Low level (when PD resistor is connected)
EXTAL XTAL 2 pins	 <ul style="list-style-type: none"> • Diagram shows circuit composition during oscillation. • Feedback resistor is removed and XTAL becomes High level during stop. 	Oscillation
PI0 PI1 2 pins		Hi-Z

Absolute Maximum Ratings

(V_{SS} = 0V reference)

Item	Symbol	Rating	Unit	Remarks
Supply voltage	V _{DD}	-0.3 to +7.0	V	
	V _{pp}	-0.3 to +13.0	V	Incorporated PROM
FDP display supply voltage	V _{FDP}	-40* ² to +7.0* ¹	V	
Input voltage	V _{IN}	-0.3 to +7.0* ¹	V	
Output voltage	V _{OUT}	-0.3 to +7.0* ¹	V	
Display output voltage	V _{OD}	-40* ² to +7.0* ¹	V	
High level output current	I _{OH}	-5	mA	All pins excluding display outputs* ³ (value per pin)
	I _{ODH1}	-15	mA	Display outputs A20 to A55 (value per pin)
	I _{ODH2}	-50	mA	Display outputs G0/A0 to G15/A15, and A16 to A19 (value per pin)
High level total output current	∑I _{OH}	-30	mA	Total for all pins excluding display outputs
	∑I _{ODH}	-120	mA	Total for all display outputs
Low level output current	I _{OL}	15	mA	Pins excluding large current output (value per pin)
	I _{OLC}	20	mA	Large current output pins* ⁴ (value per pin)
Low level total output current	∑I _{OL}	100	mA	Total for all output pins
Operating temperature	T _{opr}	-20 to +75	°C	
Storage temperature	T _{stg}	-55 to +150	°C	
Allowable power dissipation	P _D	600	mW	

*¹ V_{IN}, V_{OUT} and V_{OD} must not exceed V_{DD} + 0.3V.

*² V_{FDP} and V_{OD} must not exceed V_{DD} - 40V.

*³ Specifies output current of general-purpose I/O ports.

*⁴ The large current drive transistor is the N-CH transistor of Port C (PC).

Note) Usage exceeding absolute maximum ratings may permanently impair the LSI. Normal operation should be conducted under the recommended operating conditions. Exceeding these conditions may adversely affect the reliability of the LSI.

Recommended Operating Conditions

(V_{SS} = 0V reference)

Item	Symbol	Min.	Max.	Unit	Remarks
Supply voltage	V _{DD}	4.5	5.5	V	Guaranteed operation range during 1/2, 1/4 frequency dividing clock modes
		3.5	5.5	V	Guaranteed operation range during 1/16 frequency dividing clock or sleep modes
		2.7	5.5	V	Guaranteed operation range with TEX clock
		2.5	5.5	V	Guaranteed data hold range during stop
High level input voltage	V _{IH}	0.7V _{DD}	V _{DD}	V	*1
	V _{IHS}	0.8V _{DD}	V _{DD}	V	*2
	V _{IHH}	0.7V _{DD}	V _{DD}	V	*3
	V _{IHEX}	V _{DD} - 0.4	V _{DD} + 0.3	V	EXTAL *4
Low level input voltage	V _{IL}	0	0.3V _{DD}	V	*1
	V _{ILS}	0	0.2V _{DD}	V	*2
	V _{ILH}	0	0.7	V	*3
	V _{ILEX}	-0.3	0.4	V	EXTAL *4
Operating temperature	T _{opr}	-20	+75	°C	

*1 Value for each pin of normal input port (PA, PB0, PB4, PB7, PC).

*2 Value of the following pins:

$\overline{\text{RST}}$, CINT, $\overline{\text{CS0/RxD}}$, SI0, SI1, $\overline{\text{SCK0}}$, $\overline{\text{SCK1}}$, $\overline{\text{EC0/INT0}}$, $\overline{\text{EC1/INT1}}$, INT2, INT3/ $\overline{\text{NMI}}$, RMC.

*3 Value for each pin (PD, PF).

*4 Specifies only during external clock input.

Electrical Characteristics

DC Characteristics

(Ta = -20 to +75°C, Vss = 0V reference)

Item	Symbol	Pins	Conditions	Min.	Typ.	Max.	Unit
High level output current	V _{OH}	PA to PD, PE6, PE7, PF to PH	V _{DD} = 4.5V, I _{OH} = -0.5mA	4.0			V
			V _{DD} = 4.5V, I _{OH} = -1.2mA	3.5			V
Low level output current	V _{OL}	PA to PC, PE6, PE7	V _{DD} = 4.5V, I _{OL} = 1.8mA			0.4	V
			V _{DD} = 4.5V, I _{OL} = 3.6mA			0.6	V
		PC	V _{DD} = 4.5V, I _{OL} = 12.0mA			1.5	V
Input current	I _{IHE}	EXTAL	V _{DD} = 5.5V, V _{IH} = 5.5V	0.5		40	μA
	I _{ILE}		V _{DD} = 5.5V, V _{IL} = 0.4V	-0.5		-40	μA
	I _{IHT}	TEX	V _{DD} = 5.5V, V _{IL} = 5.5V	0.1		10	μA
			V _{DD} = 5.5V, V _{IL} = 0.4V	-0.1		-10	μA
	I _{ILR}	$\overline{\text{RST}}$	V _{DD} = 5.5V, V _{IL} = 0.4V	-1.5		-400	μA
	I _{IL}	PA to PC*1				-50	μA
Display output current	I _{OH}	A20 to A55	V _{DD} = 4.5V V _{OH} = V _{DD} - 2.5V	-8			mA
		G0/A0 to G15/A15, A16 to A19		-30			mA
Open drain output leakage current (P-CH Tr off state)	I _{LOL}	G0/A0 to G15/A15, A16 to A55	V _{DD} = 5.5V V _{OL} = V _{DD} - 35V V _{FDP} = V _{DD} - 35V			-20	μA
Pull-down resistance	R _L	G0/A0 to G15/A15, A16 to A23	V _{DD} = 5V V _{OD} - V _{FDP} = 30V	30	70	220	kΩ
I/O leakage current	I _{Iz}	PA to PC*1, PD*2, PE0 to PE5, PF*2, PI	V _{DD} = 5.5V V _I = 0, 5.5V			±10	μA

Item	Symbol	Pins	Conditions	Min.	Typ.	Max.	Unit
Supply current*3	I _{DD1}	V _{DD}	1/2 frequency dividing clock mode operation		27	55	mA
			V _{DD} = 5.5V, 16MHz crystal oscillation (C ₁ = C ₂ = 15pF)				
	I _{DD2}		V _{DD} = 3V, 32kHz crystal oscillation (C ₁ = C ₂ = 47pF)		35	110	μA
	I _{DDS1}		Sleep mode		1.5	8	mA
			V _{DD} = 5.5V, 16MHz crystal oscillation (C ₁ = C ₂ = 15pF)				
	I _{DDS2}		V _{DD} = 3V, 32kHz crystal oscillation (C ₁ = C ₂ = 47pF)		15	30	μA
I _{DDS3}	Stop mode V _{DD} = 5.5V, termination of 16MHz and 32kHz oscillation				10	μA	
Input capacity	C _{IN}	PA to PC, PD*2, PE0 to PE5, PF*2, PI, EXTAL, <u>RST</u>	Clock 1MHz 0V for all pins excluding measured pins		10	20	pF

*1 PA to PC pins specify the input current when pull-up resistor has been selected; leakage current when no resistor has been selected.

*2 PD and PF pins specify when they are used as input pins by program.

*3 When all pins are open.

AC Characteristics

(1) Clock timing

(Ta = -20 to +75°C, VDD = 4.5 to 5.5V, VSS = 0V reference)

Item	Symbol	Pin	Conditions	Min.	Typ.	Max.	Unit
System clock frequency	fc	XTAL EXTAL	Fig. 1, Fig. 2	1		16	MHz
System clock input pulse width	t _{XL} t _{XH}	EXTAL	Fig. 1, Fig. 2 External clock drive	28			ns
System clock input rise time, fall time	t _{CR} t _{CF}	EXTAL	Fig. 1, Fig. 2 External clock drive	t _{sys} + 50*1		200	ns
Event count input clock pulse width	t _{EH} t _{EL}	EC0, EC1	Fig. 3				ns
Event count input clock rise time, fall time	t _{ER} t _{EF}	EC0, EC1	Fig. 3			20	ms
System clock frequency	fc	TEX TX	VDD = 2.7 to 5.5V Fig. 2 (32kHz clock applied condition)		32.768		kHz
Event count input pulse width	t _{TL} t _{TH}	TEX	Fig. 3	10			μs
Event count input rise time, fall time	t _{TR} t _{TF}	TEX	Fig. 3			20	ms

*1 t_{sys} indicates the three values below according to the upper two bits (CPU clock selection) of the control clock register (CLC: 00FEh).

t_{sys} [ns] = 2000/fc (upper two bits = "00"), 4000/fc (upper two bits = "01"), 16000/fc (upper two bits = "11")

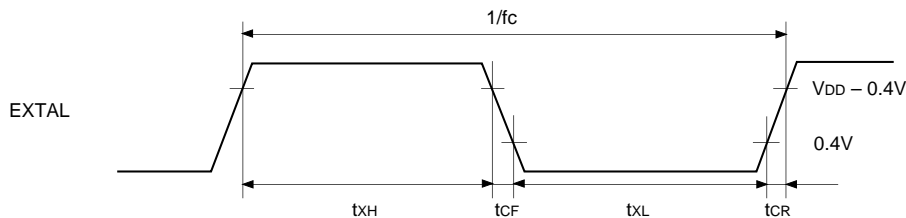

Fig. 1. Clock timing

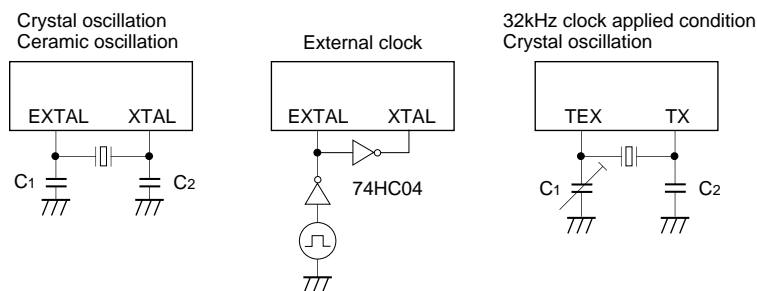

Fig. 2. Clock applied conditions

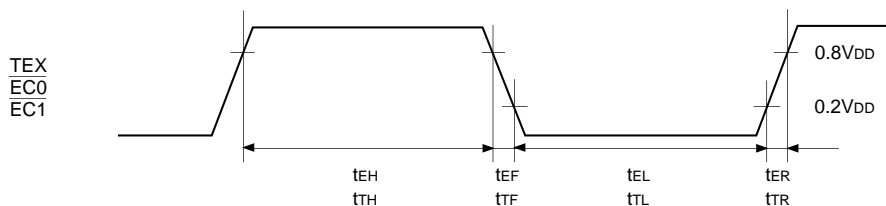

Fig. 3. Event count clock timing

(2) Serial transfer (CH0)

(Ta = -20 to +75°C, VDD = 4.5 to 5.5V, VSS = 0V reference)

Item	Symbol	Pin	Condition	Min.	Max.	Unit
$\overline{\text{CS0}} \downarrow \rightarrow \overline{\text{SCK0}}$ delay time	t_{DCSK}	$\overline{\text{SCK0}}$	Chip select transfer mode ($\overline{\text{SCK0}}$ = output mode)		$t_{\text{sys}} + 200$	ns
$\overline{\text{CS0}} \uparrow \rightarrow \overline{\text{SCK0}}$ float delay time	t_{DCSKF}	$\overline{\text{SCK0}}$	Chip select transfer mode ($\overline{\text{SCK0}}$ = output mode)		$t_{\text{sys}} + 200$	ns
$\overline{\text{CS0}} \downarrow \rightarrow \text{SO0}$ delay time	t_{DCSO}	SO0	Chip select transfer mode		$t_{\text{sys}} + 200$	ns
$\overline{\text{CS0}} \uparrow \rightarrow \text{SO0}$ float delay time	t_{DCSOF}	SO0	Chip select transfer mode		$t_{\text{sys}} + 200$	ns
$\overline{\text{CS0}}$ High level width	t_{WHCS}	$\overline{\text{CS0}}$	Chip select transfer mode	$t_{\text{sys}} + 200$		ns
$\overline{\text{SCK0}}$ cycle time	t_{KCY}	$\overline{\text{SCK0}}$	Input mode	$2t_{\text{sys}} + 200$		ns
			Output mode	$16000/f_c$		ns
$\overline{\text{SCK0}}$ High, Low level width	t_{KH} t_{KL}	$\overline{\text{SCK0}}$	Input mode	$t_{\text{sys}} + 100$		ns
			Output mode	$8000/f_c - 50$		ns
SI0 input setup time (for $\overline{\text{SCK0}} \uparrow$)	t_{SIK}	SI0	$\overline{\text{SCK0}}$ input mode	100		ns
			$\overline{\text{SCK0}}$ output mode	200		ns
SI0 input hold time (for $\overline{\text{SCK0}} \uparrow$)	t_{KSI}	SI0	$\overline{\text{SCK0}}$ input mode	$t_{\text{sys}} + 200$		ns
			$\overline{\text{SCK0}}$ output mode	100		ns
$\overline{\text{SCK0}} \downarrow \rightarrow \text{SO0}$ delay time	t_{KSO}	SO0	$\overline{\text{SCK0}}$ input mode		$t_{\text{sys}} + 200$	ns
			$\overline{\text{SCK0}}$ output mode		100	ns

Note 1) t_{sys} indicates the three values below according to the upper two bits (CPU clock selection) of the control clock register (CLC: 00FEh).

t_{sys} [ns] = 2000/ f_c (upper two bits = "00"), 4000/ f_c (upper two bits = "01"), 16000/ f_c (upper two bits = "11")

Note 2) The load condition for the $\overline{\text{SCK0}}$ output mode, SO0 output delay time is 50pF + 1TTL.

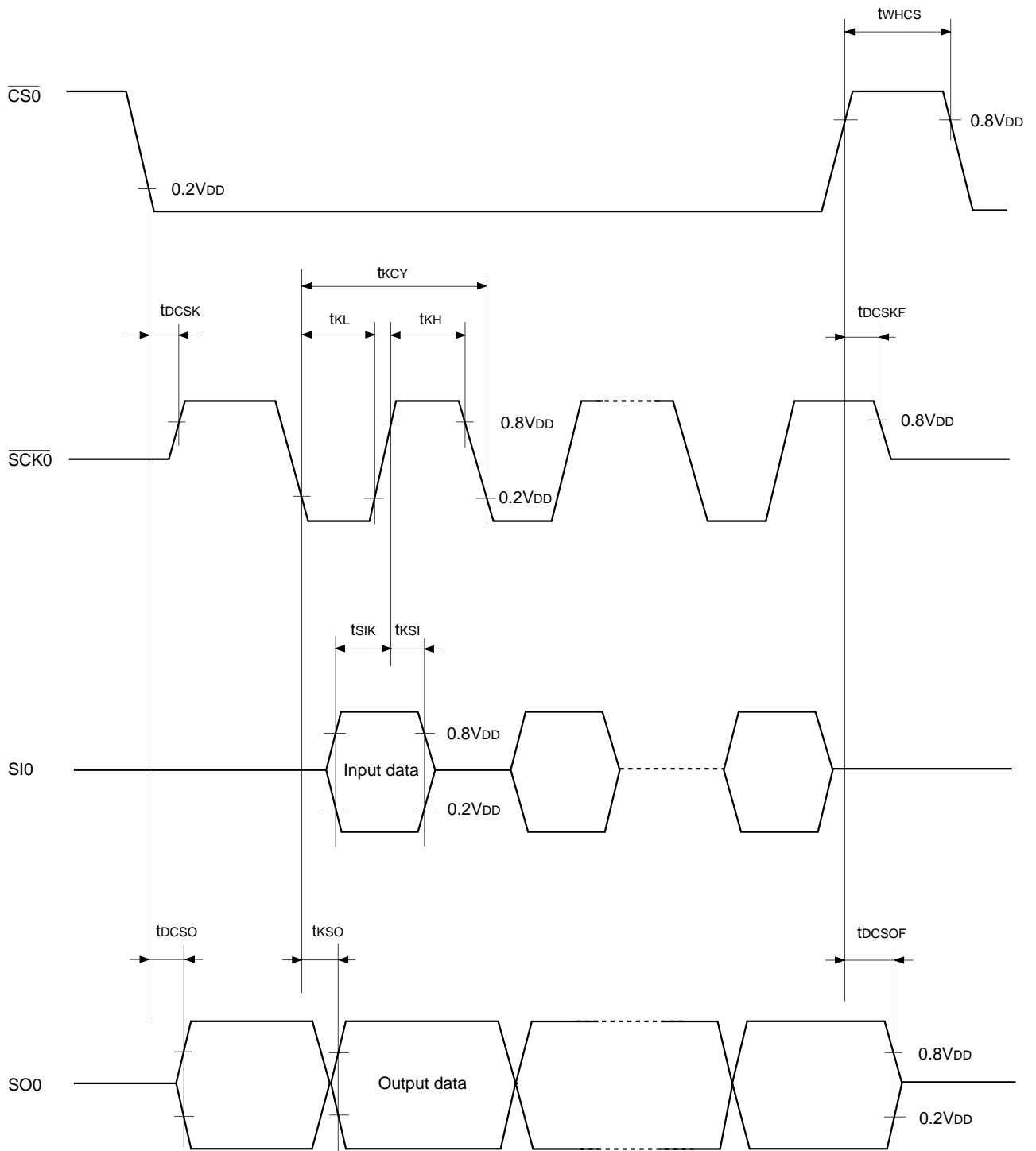

Fig. 4. Serial transfer CH0 timing

Serial transfer (CH1)

($T_a = -20$ to $+75^\circ\text{C}$, $V_{DD} = 4.5$ to 5.5V , $V_{SS} = 0\text{V}$ reference)

Item	Symbol	Pin	Condition	Min.	Max.	Unit
$\overline{\text{SCK1}}$ cycle time	t_{KCY}	$\overline{\text{SCK1}}$	Input mode	1000		ns
			Ouput mode	$16000/f_c$		ns
$\overline{\text{SCK1}}$ High, Low level width	t_{KH} t_{KL}	$\overline{\text{SCK1}}$	Input mode	400		ns
			Ouput mode	$8000/f_c - 50$		ns
SI1 input setup time (for $\overline{\text{SCK1}} \uparrow$)	t_{SIK}	SI1	$\overline{\text{SCK1}}$ input mode	100		ns
			$\overline{\text{SCK1}}$ ouput mode	200		ns
SI1 input hold time (for $\overline{\text{SCK1}} \uparrow$)	t_{KSI}	SI1	$\overline{\text{SCK1}}$ input mode	200		ns
			$\overline{\text{SCK1}}$ ouput mode	100		ns
$\overline{\text{SCK1}} \downarrow \rightarrow \text{SO1}$ delay time	t_{KSO}	SO1	$\overline{\text{SCK1}}$ input mode		200	ns
			$\overline{\text{SCK1}}$ ouput mode		100	ns

Note) The load condition for the $\overline{\text{SCK1}}$ output mode, SO1 output delay time is $50\text{pF} + 1\text{TTL}$.

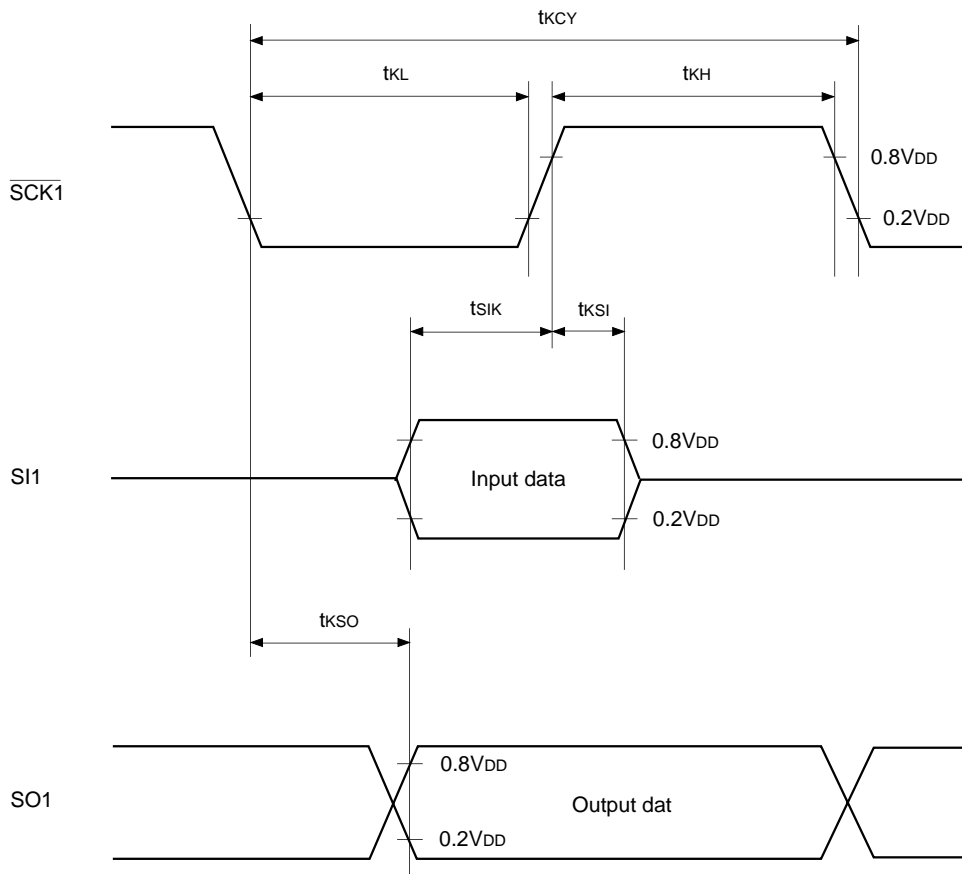
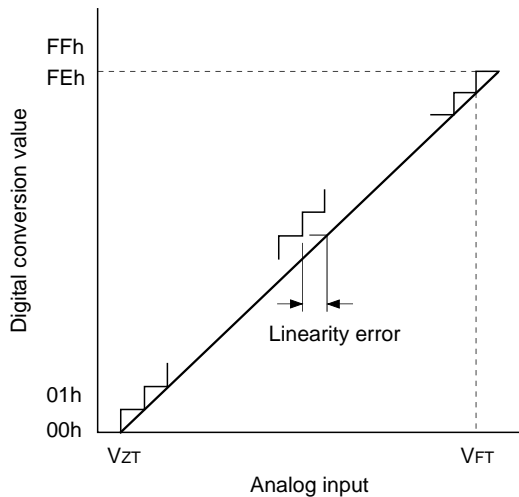

Fig. 5. Serial transfer CH1 timing

(3) A/D converter characteristics

($T_a = -20$ to $+75^\circ\text{C}$, $V_{DD} = 4.5$ to 5.5V , $V_{SS} = 0\text{V}$ reference)

Item	Symbol	Pin	Condition	Min.	Typ.	Max.	Unit
Resolution						8	Bits
Linearity error			$T_a = 25^\circ\text{C}$ $V_{DD} = 5.0\text{V}$ $V_{SS} = 0\text{V}$			± 3	LSB
Zero transition voltage	V_{ZT}^{*1}			-10	10	70	mV
Full-scale transition voltage	V_{FT}^{*2}			4910	4970	5030	mV
Conversion time	t_{CONV}			$26/f_{ADC}^{*3}$			μs
Sampling time	t_{SAMP}			$6/f_{ADC}^{*3}$			μs
Analog input voltage	V_{IAN}	AN0 to AN7		0		V_{DD}	V



*1 V_{ZT} : Value at which the digital conversion value changes from 00h to 01h and vice versa.

*2 V_{FT} : Value at which the digital conversion value changes from FEh to FFh and vice versa.

*3 f_{ADC} indicates the below values due to the contents of bit 6 (CKS) of the A/D control register (ADC: 00F9h) and bits 7 (PCK1) and 6 (PCK0) of the clock control register (CLC: 00FEh).

However, the selection for $f_{ADC} = f_c$ (CKS = "0") is limited in the clock range of $f_c = 1$ to 14MHz ($V_{DD} = 4.5$ to 5.5V).

Fig. 6. Definition of A/D converter terms

(4) Interruption, reset input (Ta = -20 to +75°C, VDD = 4.5 to 5.5V, Vss = 0V reference)

Item	Symbol	Pin	Condition	Min.	Max.	Unit
External interruption High, Low level width	t _{IH} t _{IL}	INT0 INT1 INT2 $\overline{\text{NMI/INT3}}$		1		μs
Reset input Low level width	t _{RSL}	$\overline{\text{RST}}$		32/fc		μs

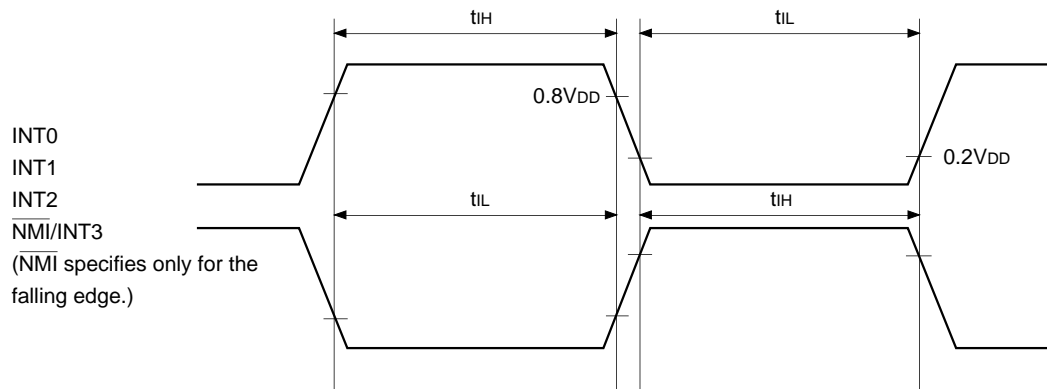

Fig. 7. Interruption input timing

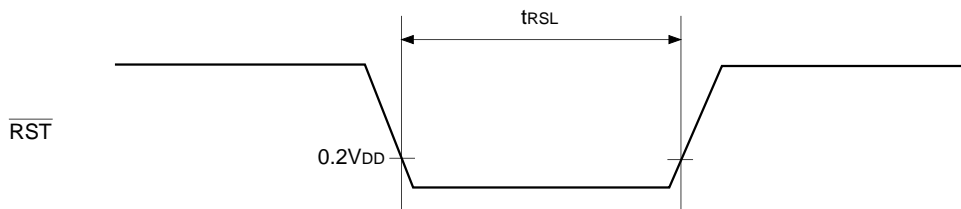

Fig. 8. $\overline{\text{RST}}$ input timing

Appendix

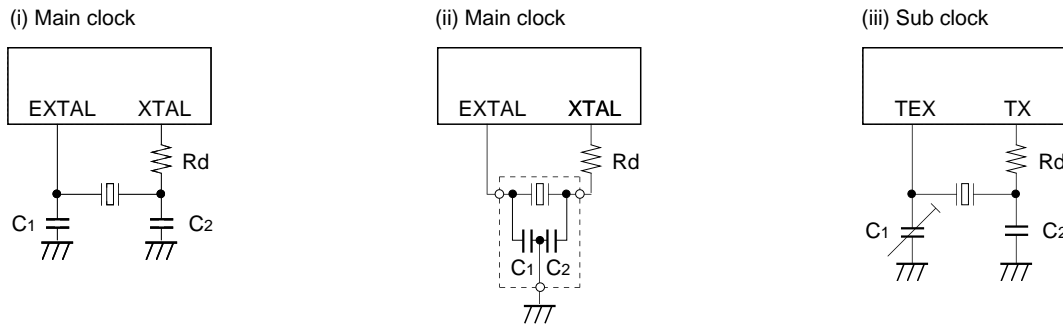

Fig. 9. Recommended oscillation circuit

Manufacturer	Model	fc (MHz)	C1 (pF)	C2 (pF)	Rd (Ω)	Circuit example	Remarks	
MURATA MFG CO., LTD.	CSA10.0MTZ	10.0	30	30	0	(i)		
	CSA12.0MTZ	12.0						
	CSA16.00MXZ040	16.0	5	5				
	CST10.0MTW*	10.0	30	30		(ii)		
	CST12.0MTW*	12.0						
	CST16.00MXW0C1*	16.0					5	5
RIVER ELETEC CO., LTD	HC-49/U03	8.0	18	18	330	(i)		
		12.0	12	12				
		16.0	10	10				
KINSEKI LTD.	HC-49/U (-S)	8.0	10	10	0		(i)	
		12.0	5	5				
		16.0	Open	Open				
Seiko Instruments Inc.	VTC-200 SP-T	32.768kHz	18	18	330k	(iii)		CL = 12.5pF

Models marked with an asterisk (*) have the built-in ground capacitance (C1, C2).

Mask Option Table

Item	Mask ROM	CXP820P60Q-1-□□□
Package	100-pin plastic QFP	100-pin plastic QFP
ROM capacitance	52K/60K byte	PROM 60K byte
Reset pin pull-up resistor	Existent/Non-existent	Existent
High voltage drive pin pull-down resistor	Existent/Non-existent	Non-existent (PH7/A24 to PD0/A55) Existent (G0/A0 to A23)

Characteristics Curve

