



### Features

- Compliant with CSFP MSA 2.0 (Option 2)
- Two Bi-Directional Transceivers in One SFP Package
- Compliant with IEEE 802.3ah, 1000Base-BX10-D
- Duplex LC Connector
- Single 3.3V Supply
- 11dB Minimum Power Budget
- 10km Minimum Reach
- 1490nm DFB Laser, PIN Receiver
- Commercial and Industrial Temperatures Available
- Digital Diagnostic
- Color Coded Bail Latch Tube: Purple
- RoHS Compliant

**Table 1 – General Operating**

Parameter	Symbol	Min.	Typical	Max.	Unit	Notes
Supply Voltage	V <sub>cc</sub>	3.135	3.3	3.465	V	
Total Current		-	-	500	mA	
Case Operating Temperature (C-temp)	T <sub>opr</sub>	-5	-	70	°C	1
Case Operating Temperature (I-temp)	T <sub>opr</sub>	-40	-	85	°C	
Storage Temperature	T <sub>stg</sub>	-40	-	85	°C	
Data Rate	DR	-	1250	-	Mbps	

Note 1: Please refer to ordering information in Table 12

**Table 2 – Transmitter Specifications (Optical) (Each Channel)**

Parameter	Symbol	Min.	Typical	Max.	Unit	Notes
Optical Power	P <sub>op</sub>	-9	-6	-3	dBm	
Average Launch Power Tx_Off	P <sub>off</sub>	-	-	-45	dBm	
Extinction Ratio	ER	6	-	-	dB	
Eye Mask		IEEE 802.3ah Compliant				
Optical Rise/Fall Time (20%~80% values)	t <sub>r</sub> /t <sub>f</sub>	-	-	260	ps	
Mean Wavelength	λ	1480	1490	1500	nm	
Spectral Width (-20dB)	Δλ	IEEE 802.3ah Table 59-4 Compliant				

**Table 3 – Transmitter Specifications (Electrical) (Each Channel)**

Parameter	Symbol	Min.	Typical	Max.	Unit	Notes
Input Differential Impedance	R <sub>in</sub>	80	100	120	Ω	
Single Ended Data Input Swing	V <sub>in, p-p</sub>	250	-	1200	mV	

TxFault_Fault	$V_{\text{fault}}$	2	-	Vcc	V	
TxFault_Normal	$V_{\text{normal}}$	Vee	-	Vee + 0.5	V	
TxDisable_Disable	$V_{\text{d}}$	2	-	Vcc	V	
TxDisable_Enable	$V_{\text{en}}$	Vee	-	Vee + 0.8	V	

**Table 4 – Receiver Specifications (Optical) (Each Channel)**

Parameter	Symbol	Min.	Typical	Max.	Unit	Notes
Receiver Power Low	$R_{\text{sens,low}}$	-	-22	-20	dBm	2
Receiver Power High	$R_{\text{sens,high}}$	-3	-	-	dBm	2
Damage Threshold For Receiver	$P_{\text{in, damage}}$	0	-	-	dBm	
Wavelength	$\lambda$	1260	-	1360	nm	
Receiver Reflectance	RX_r	-	-	-12	dB	
LOS Assert	-	-45	-	-	dBm	
LOS De-Assert	-	-	-	-20	dBm	
LOS Hysteresis	-	0.5	-	5	dB	

 Note 2: Measured at  $10^{-12}$  BER, PRBS  $2^7-1$ , 6dB ER

**Table 5 – Receiver Specifications (Electrical) (Each Channel)**

Parameter	Symbol	Min.	Typical	Max.	Unit	Notes
Single Ended Data Output Swing	$V_{\text{out,p-p}}$	185	-	1000	mV	
Data Output Rise/Fall Time	$t_r/t_f$	-	-	500	ps	
RX_LOS Voltage (High)	RX_LOS <sub>H</sub>	2	-	-	V	
RX_LOS Voltage (Low)	RX_LOS <sub>L</sub>	-	-	0.8	V	
LOS Output Voltage-Fault	$V_{\text{LOS fault}}$	2	-	V <sub>cc</sub>	V	
LOS Output Voltage-Normal	$V_{\text{LOS normal}}$	V <sub>ee</sub>	-	V <sub>ee</sub> + 0.5	V	

**Table 6 – Timing and Electrical (Each Channel)**

Parameter	Symbol	Min.	Typical	Max.	Unit	Notes
Tx Disable Negate Time	$t_{\text{on}}$	-	-	1	ms	
Tx Disable Assert Time	$t_{\text{off}}$	-	-	10	μs	
Time to Initialize, Including Reset of Tx Fault	$t_{\text{init}}$	-	-	300	ms	
Tx Fault Assert Time	$t_{\text{fault}}$	-	-	100	μs	
Tx Disable to Reset	$t_{\text{reset}}$	10	-	-	μs	
LOS Assert Time	$t_{\text{loss_on}}$	-	-	100	μs	
LOS De-Assert Time	$t_{\text{loss_off}}$	-	-	100	μs	
Serial ID Clock Rate	$f_{\text{serial\_clock}}$	-	-	100	kHz	

**Table 7 – Diagnostics**

Parameter	Range	Accuracy	Unit	Calibration	Formula
Temperature (C-Temp)	-5 to 70	±3	°C	External	$T_c(C) = T_{slope} * T_{ad}(16 \text{ bit signed twos complement value}) + T_{offset}$
Temperature (I-temp)	-40 to 85	±3	°C	External	$T_c(C) = T_{slope} * T_{ad}(16 \text{ bit signed twos complement value}) + T_{offset}$
Voltage	2.97 to 3.63	±3%	V	External	$V(\text{Volts}) = V_{slope} * V_{ad} (16 \text{ bit unsigned integer}) + V_{offset}$
Bias Current	0 to 100	±10%	mA	External	$I(\text{mA}) = I_{slope} * I_{ad}(16 \text{ bit unsigned integer}) + I_{offset}$
Tx Power	-9 to -3	±3	dBm	External	$Tx\_PWR(\mu W) = Tx\_PWR_{slope} * Tx\_PWR_{ad} (16 \text{ bit unsigned integer}) + Tx\_PWR_{offset}$
Rx Power	-20 to -3	±3	dBm	External	$Rx\_PWR(\mu W) = A_0 + A_1 * x + A_2 * x^2 + A_3 * x^3 + A_4 * x^4$

**Table 8 – EEPROM Serial ID (A0h for Channel 1; B0h for Channel 2)**

Name of Field	Description of Field	Address	Hex	ASCII
Identifier	Type of serial transceiver	0	03	
Ext. Identifier	Extended identifier of type of serial transceiver	1	04	
Connector	Code for connector type	2	07	
Transceiver	Code for electronic compatibility or optical compatibility	3	00	
		4	00	
		5	00	
		6	40	
		7	00	
		8	00	
		9	00	
		10	00	
Encoding	Code for serial encoding algorithm	11	01	
BR.Nominal	Units of 100 MBits/sec.	12	0D	
Reserved	Reserved	13	00	
Length (9µm,km)	9/125 µm fiber, units of km	14	0A	
Length (9µm)	9/125 µm fiber, units of 100 m	15	64	
Length (50µm)	50/125 µm fiber, units of 10 m	16	00	
Length (62.5µm)	62.5/125 µm fiber, units of 10 m	17	00	
Length (Copper)	Units of meters	18	00	
Reserved	Reserved	19	00	
Vendor Name	SFP vendor name (ASCII)	20	53	S
		21	4F	O
		22	55	U
		23	52	R
		24	43	C
		25	45	E
		26	50	P
		27	48	H
		28	4F	O
		29	54	T
		30	4F	O
		31	4E	N
		32	49	I
		33	43	C
		34	53	S
		35	20	[Space]

**Table 8 – EEPROM Serial ID (A0h for Channel 1; B0h for Channel 2)**

Name of Field	Description of Field	Address	Hex	ASCII
Reserved	Reserved	36	00	
Vendor OUI	SFP vendor IEEE company ID for Source Photonics Inc.	37	00	
		38	1F	
		39	22	
Vendor P/N	Part number in ASCII, e.g. SPLC43GBBXCDFA	40	53	S
		41	50	P
		42	4C	L
		43	43	C
		44	34	4
		45	33	3
		46	47	G
		47	42	B
		48	42	B
		49	58	X
		50	43	C
		51	44	D
		52	46	F
		53	41	A
54	20	[Space]		
55	20	[Space]		
Vendor Rev.	Revision level for part number provide by vendor (ASCII)	56	31	
		57	30	
		58	20	
		59	20	
Wavelength	1490nm	60	05	
		61	D2	
Reserved	Reserved	62	00	
CC_BASE	Check code for Base ID Fields (addresses 0 to 62)	63	xx	
Options	Indicates which optional transceiver signals are implemented	64	00	
		65	1A	

**Table 8 – EEPROM Serial ID (A0h for Channel 1; B0h for Channel 2)**

Name of Field	Description of Field	Address	Hex	ASCII
BR, max	Upper bit rate margin, unit of %	66	00	
BR, min	Lower bit rate margin, unit of %	67	00	
Vendor S/N	Serial number	68-83	xx	
Date Code	Vendor's manufacturing date code	84-91	xx	
Diagnostic Monitoring Type	Indicates which type of diagnostic monitoring is implemented in the transceiver	92	58	
Enhanced Options	Indicates which optional enhanced features are implemented in the transceiver	93	B0	
SFF-8472 Compliance	Indicates which revision of SFF-8472 the transceiver complies with	94	02	
CC_EXT	Check code for Extended ID Fields (addresses 64 to 94)	95	xx	
Vendor Specific	Vendor Specific EEPROM	96-127	xx	

**Table 9 – Digital Diagnostic EEPROM (A2h for Channel 1; B2h for Channel 2)**

Address	# Bytes	Name	Description	Value
00-01	2	Temp High Alarm	MSB at low address	
02-03	2	Temp Low Alarm	MSB at low address	
04-05	2	Temp High Warning	MSB at low address	
06-07	2	Temp Low Warning	MSB at low address	
08-09	2	Voltage High Alarm	MSB at low address	
10-11	2	Voltage Low Alarm	MSB at low address	
12-13	2	Voltage High Warning	MSB at low address	
14-15	2	Voltage Low Warning	MSB at low address	
16-17	2	Bias High Alarm	MSB at low address	
18-19	2	Bias Low Alarm	MSB at low address	
20-21	2	Bias High Warning	MSB at low address	
22-23	2	Bias Low Warning	MSB at low address	
24-25	2	TX Power High Alarm	MSB at low address	

26-27	2	TX Power Low Alarm	MSB at low address	
28-29	2	TX Power High Warning	MSB at low address	
30-31	2	TX Power Low Warning	MSB at low address	
32-33	2	RX Power High Alarm	MSB at low address	
34-35	2	RX Power Low Alarm	MSB at low address	
36-37	2	RX Power High Warning	MSB at low address	
38-39	2	RX Power Low Warning	MSB at low address	
40-55	16	Reserved	Reserved for future monitored quantities	
56-59	4	Rx_PWR(4)	Single precision floating point calibration data - Rx optical power. Bit 7 of byte 56 is MSB. Bit 0 of byte 59 is LSB.	
60-63	4	Rx_PWR(3)	Single precision floating point calibration data - Rx optical power. Bit 7 of byte 60 is MSB. Bit 0 of byte 63 is LSB.	
64-67	4	Rx_PWR(2)	Single precision floating point calibration data, Rx optical power. Bit 7 of byte 64 is MSB, bit 0 of byte 67 is LSB.	
68-71	4	Rx_PWR(1)	Single precision floating point calibration data, Rx optical power. Bit 7 of byte 68 is MSB, bit 0 of byte 71 is LSB.	
72-75	4	Rx_PWR(0)	Single precision floating point calibration data, Rx optical power. Bit 7 of byte 72 is MSB, bit 0 of byte 75 is LSB.	
76-77	2	Tx_I(Slope)	Fixed decimal (unsigned) calibration data, laser bias current. Bit 7 of byte 76 is MSB, bit 0 of byte 77 is LSB.	
78-79	2	Tx_I(Offset)	Fixed decimal (signed two's complement) calibration data, laser bias current. Bit 7 of byte 78 is MSB, bit 0 of byte 79 is LSB.	
80-81	2	Tx_PWR(Slope)	Fixed decimal (unsigned) calibration data, transmitter coupled output power. Bit 7 of byte 80 is MSB, bit 0 of byte 81 is LSB.	
82-83	2	Tx_PWR(Offset)	Fixed decimal (signed two's complement) calibration data, transmitter coupled output power. Bit 7 of byte 82 is MSB, bit 0 of byte 83 is LSB.	
84-85	2	T (Slope)	Fixed decimal (unsigned) calibration data, internal module temperature. Bit 7 of byte 84 is MSB, bit 0 of byte 85 is LSB.	

86-87	2	T (Offset)	Fixed decimal (signed two's complement) calibration data, internal module temperature. Bit 7 of byte 86 is MSB, bit 0 of byte 87 is LSB.
88-89	2	V (Slope)	Fixed decimal (unsigned) calibration data, internal module supply voltage. Bit 7 of byte 88 is MSB, bit 0 of byte 89 is LSB.
90-91	2	V (Offset)	Fixed decimal (signed two's complement) calibration data, internal module supply voltage. Bit 7 of byte 90 is MSB. Bit 0 of byte 91 is LSB.
92-94	3	Reserved	Reserved
95	1	Checksum	Byte 95 contains the low order 8 bits of the sum of bytes 0 – 94.

**Table 10 – A/D Values and Status Bits (A2h for Channel 1; B2h for Channel 2)**

Byte	Bit	Name	Description
96	All	Temperature MSB	Internally measured module temperature.
97	All	Temperature LSB	
98	All	Vcc MSB	Internally measured supply voltage in transceiver.
99	All	Vcc LSB	
100	All	TX Bias MSB	Internally measured TX Bias Current.
101	All	TX Bias LSB	
102	All	TX Power MSB	Measured TX output power.
103	All	TX Power LSB	
104	All	RX Power MSB	Measured RX input power.
105	All	RX Power LSB	
106	All	Reserved MSB	Reserved
107	All	Reserved LSB	
108	All	Reserved MSB	
109	All	Reserved LSB	
110	7	TX Disable State	
	6	Soft TX Disable	Read/write bit that allows software disable of laser. Writing '1' disables laser.
	5	Channel Shut Down Control	Read/write bit that allows shutting down Ch1 or Ch2 power supply and Ch1 or Ch2 is under the low power dissipation mode. Write '1' to shut down Ch1 or Ch2 and write '0' to turn on Ch1 or Ch2. Default power up value is zero/low.



	4	Rate Select State	Rate select is not implemented.
	3	Soft Rate Select	
	2	Tx Fault	Digital state of the TX Fault Output Pin. Updated within 100msec of change on pin.
	1	LOS	Digital state of the LOS Output Pin. Updated within 100msec of change on pin.
	0	Data_Ready_Bar	Indicates transceiver has achieved power up and data is ready. Bit remains high until data is ready to be read at which time the device sets the bit low.
111	All	Reserved	Reserved
112	7	Temp High Alarm	Set when internal temperature exceeds high alarm level.
	6	Temp Low Alarm	Set when internal temperature is below low alarm level.
	5	Vcc High Alarm	Set when internal supply voltage exceeds high alarm level.
	4	Vcc Low Alarm	Set when internal supply voltage is below low alarm level.
	3	Tx Bias High Alarm	Set when internal supply voltage exceeds high alarm level.
	2	Tx Bias Low Alarm	Set when internal supply voltage is below low alarm level.
	1	Rx Power High Alarm	Set when TX output power exceeds high alarm level.
	0	Rx Power Low Alarm	Set when TX output power is below low alarm level.
113	7	Vcc High Alarm	Set when Received Power exceeds high alarm level.
	6	Vcc Low Alarm	Set when Received Power is below low alarm level.
	5-0	Reserved	Reserved
114	All	Reserved	Reserved
115	All	Reserved	Reserved
116	7	Temp High Warning	Set when internal temperature exceeds high Warning level.
	6	Temp Low Warning	Set when internal temperature is below low Warning level.
	5	Vcc High Warning	Set when internal supply voltage exceeds high Warning level.
	4	Vcc Low Warning	Set when internal supply voltage is below low Warning level.
	3	Tx Bias High Warning	Set when internal supply voltage exceeds high Warning level.
	2	Tx Bias Low Warning	Set when internal supply voltage is below low Warning level.
	1	Rx Power High Warning	Set when TX output power exceeds high Warning level.
	0	Rx Power Low Warning	Set when TX output power is below low Warning level.
117	7	Vcc High Warning	Set when Received Power exceeds high Warning level.
	6	Vcc Low Warning	Set when Received Power is below low Warning level.

	5-0	Reserved	Reserved
118	All	Reserved	Reserved
119	All	Reserved	Reserved
120-127	All	Vendor Specific	Vendor Specific

**Table 11 – Pin Definitions**

Pin Number	Name	Chanel Number	Function	Plug Sequence	Note
1	VeeT	Common	Transceiver Ground	1	
2	TX_Fault	Common	Transmitter Fault Indicationi	3	1
3	TX1_Disable	1	Transmitter Disable of Ch1; Turns off transmitter laser output of Ch1	3	
4	MOD_DEF2	Common	2-wire Serial Interface Data Line (SDA)	3	
5	MOD_DEF1	Common	2-wire Serial Interface Clock (SCL)	3	
6	TD2-	2	Inverted Transmit Data Input of Ch2	3	
7	TD2+	2	Transmit Data Input of Ch2	3	
8	LOS1	1	Loss of signal for Ch1	3	
9	RD2+	2	Received Data Output of Ch2	3	
10	RD2-	2	Inverted Received Data Output of Ch2	3	
11	Vee	Common	Transceiver Ground	1	
12	RD1-	1	Inverted Received Data Output of Ch1	3	
13	RD1+	1	Received Data Output of Ch1	3	
14	LOS2	2	Loss of signal for Ch2	3	
15	VccR	Common	Receiver Power	2	
16	VccT	Common	Transmitter Power	2	
17	Tx2_Disable	2	Transmitter Disable of Ch2; Turns off transmitter laser output of Ch2	3	
18	TD1+	1	Transmit Data Input of Ch1	3	
19	TD1-	1	Inverted Transmit Data Input of Ch1	3	
20	Vee	Common	Transceiver Ground	1	

Note 1: TX\_Fault is internally OR output for TX fault conditions in either Channel 1 or Channel 2. In order o determine which channel is at fault, the Host can read the internal memory bits for status:

- Bit2 in (A2h: 110) for TX1 fault
- Bit2 in (B2h: 110) for TX2 fault

### Recommended Interface Circuit

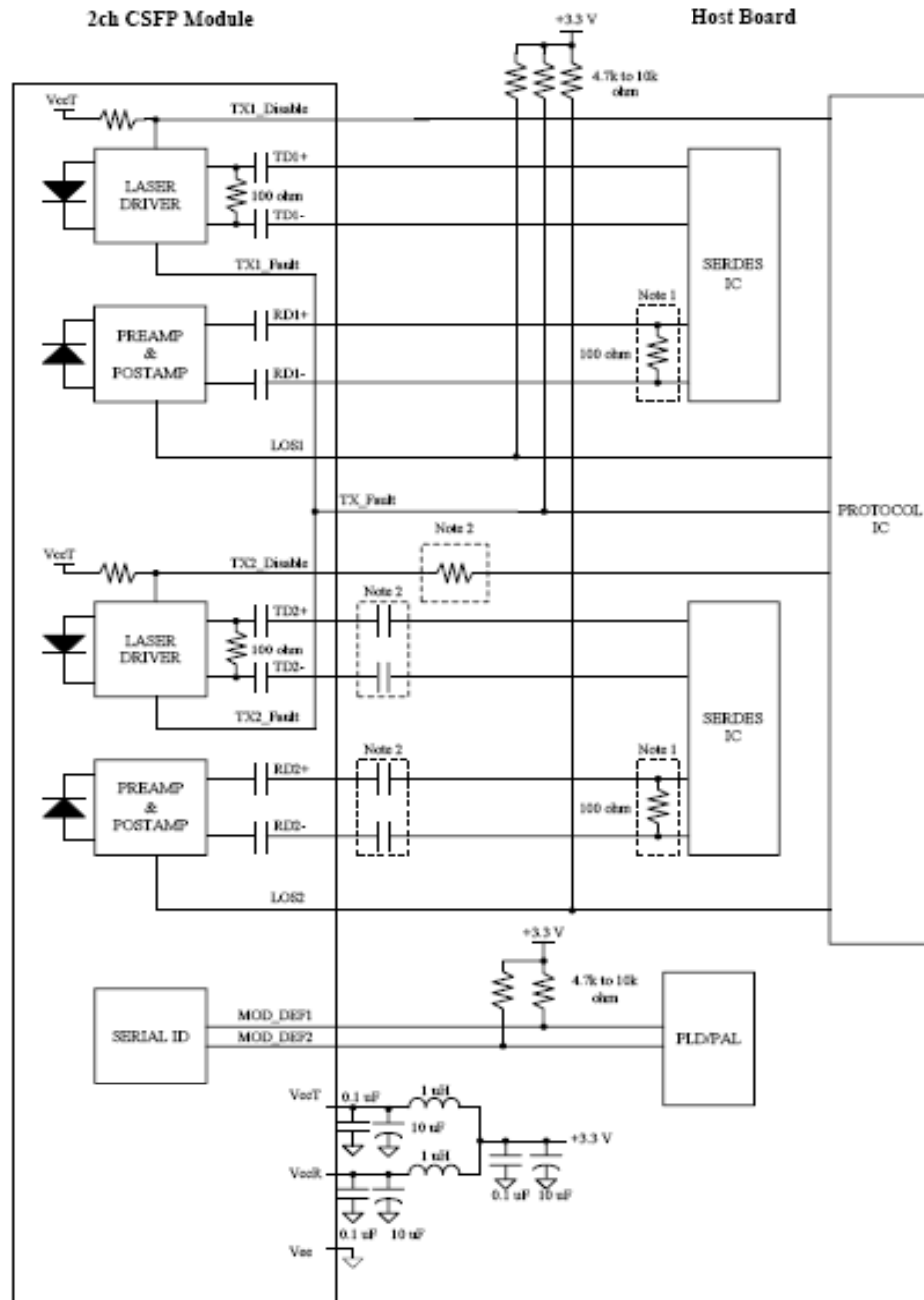

Note 1. Consult the SERDES manufacturer for the termination method.

Note 2. Protections from incorrect insertion are strongly recommended.

### Mechanical Diagram

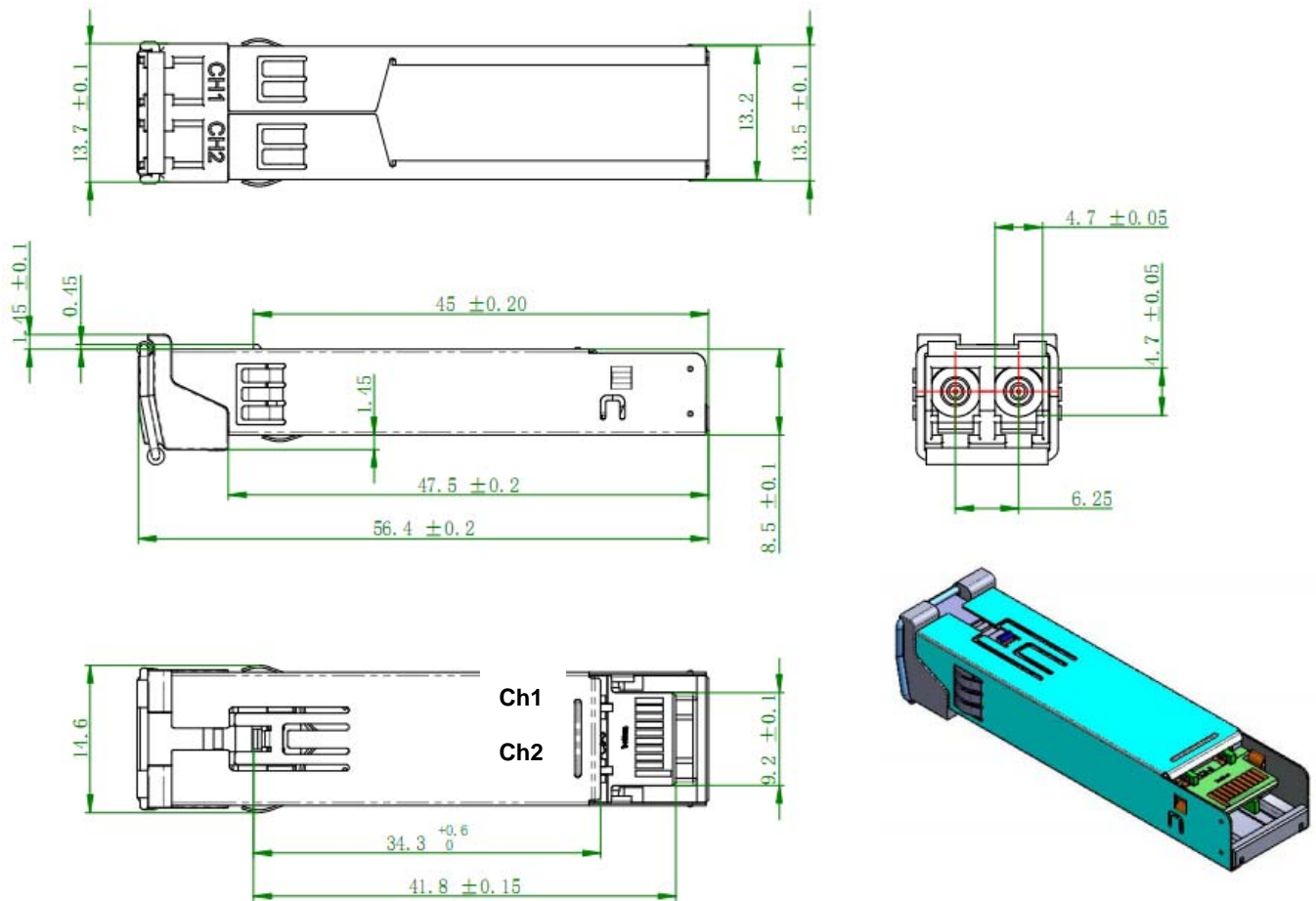

### Order Information

Table 12 – Ordering Information

Part No.	Description
SPLC-43-GB-BX-CDFA	CSFP, 1000BASE-BX10-D, 1490nm Tx, 1310nm Rx, C-temp, with Digital Diagnostic, RoHS Compliant
SPLC-43-GB-BX-IDFA	CSFP, 1000BASE-BX10-D, 1490nm Tx, 1310nm Rx, I-temp, with Digital Diagnostic, RoHS Compliant

## Warnings

**Handling Precautions:** This device is susceptible to damage as a result of electrostatic discharge (ESD). A static free environment is highly recommended. Follow guidelines according to proper ESD procedures.

**Laser Safety:** Radiation emitted by laser devices can be dangerous to human eyes. Avoid eye exposure to direct or indirect radiation.

## Legal Notice

### IMPORTANT NOTICE!

All information contained in this document is subject to change without notice, at Source Photonics' sole and absolute discretion. Source Photonics warrants performance of its products to current specifications only in accordance with the company's standard one-year warranty; however, specifications designated as "preliminary" are given to describe components only, and Source Photonics expressly disclaims any and all warranties for said products, including express, implied, and statutory warranties, warranties of merchantability, fitness for a particular purpose, and non-infringement of proprietary rights. Please refer to the company's Terms and Conditions of Sale for further warranty information.

Source Photonics assumes no liability for applications assistance, customer product design, software performance, or infringement of patents, services, or intellectual property described herein. No license, either express or implied, is granted under any patent right, copyright, or intellectual property right, and Source Photonics makes no representations or warranties that the product(s) described herein are free from patent, copyright, or intellectual property rights. Products described in this document are NOT intended for use in implantation or other life support applications where malfunction may result in injury or death to persons. Source Photonics customers using or selling products for use in such applications do so at their own risk and agree to fully defend and indemnify Source Photonics for any damages resulting from such use or sale.

THE INFORMATION CONTAINED IN THIS DOCUMENT IS PROVIDED ON AN "AS IS" BASIS. Customer agrees that Source Photonics is not liable for any actual, consequential, exemplary, or other damages arising directly or indirectly from any use of the information contained in this document. Customer must contact Source Photonics to obtain the latest version of this publication to verify, before placing any order, that the information contained herein is current.

## Contact

### U.S.A. Headquarters

20550 Nordhoff Street  
Chatsworth, CA 91311  
USA

Tel: +1-818-773-9044

Fax: +1-818-773-0261

[sales@sourcephotonics.com](mailto:sales@sourcephotonics.com)

### China

Building #2&5, West Export Processing Zone  
No. 8 Kexin Road, Hi-Tech Zone  
Chengdu, 611731, China

Tel: +86-28-8795-8788

Fax: +86-28-8795-8789

[sales@sourcephotonics.com.cn](mailto:sales@sourcephotonics.com.cn)

### Taiwan

9F, No 81, Shui Lee Rd.  
Hsinchu, 300, Taiwan  
R.O.C.

Tel: +886-3-5169222

Fax: +886-3-5169213

[sales@sourcephotonics.com.tw](mailto:sales@sourcephotonics.com.tw)

© Copyright Source Photonics, Inc. 2007-2012

All rights reserved