

[ Obsolete product ]

Agilent has a new name

Keysight Technologies.

Keysight Technologies Inc. is the world's leading electronic measurement company, transforming today's measurement experience through innovations in wireless, modular, and software solutions. With its HP and Agilent legacy, Keysight delivers solutions in wireless communications, aerospace and defense and semiconductor markets with world-class platforms, software and consistent measurement science.

# Agilent HSDL-3602 IrDA<sup>®</sup> Data 1.4 Compliant 4 Mb/s 3V Infrared Transceiver Data Sheet

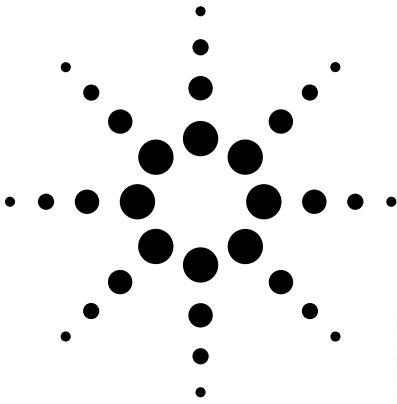

## Description

The HSDL-3602 is a low-height infrared transceiver module that provides interface between logic and IR signals for through-air, serial, half-duplex IR data link. The module is compliant to IrDA Data Physical Layer Specifications 1.1 and IEC825-Class 1 Eye Safety Standard.

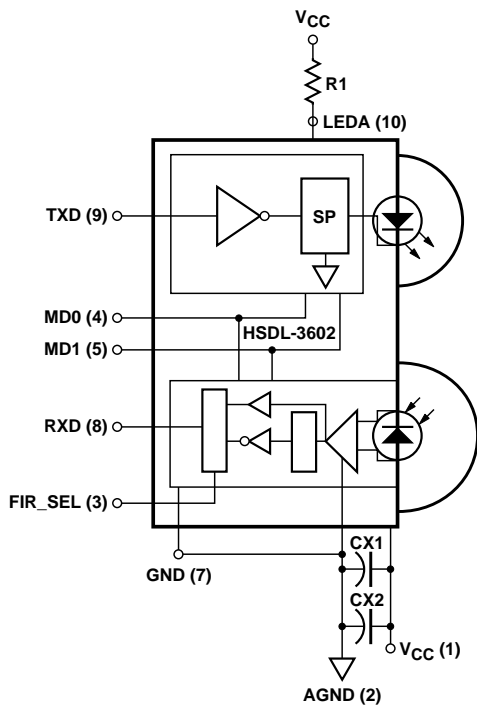

HSDL-3602 Functional block diagram

## Applications

- **Digital imaging**
  - Digital still cameras
  - Photo-imaging printers
- **Data communication**
  - Notebook computers
  - Desktop PCs
  - Win CE handheld products
  - Personal Digital Assistants (PDAs)
  - Printers
  - Fax machines, photocopiers
  - Screen projectors
  - Auto PCs
  - Dongles
  - Set-top box
- **Telecommunication products**
  - Cellular phones
  - Pagers
- **Small industrial and medical instrumentation**
  - General data collection devices
  - Patient and pharmaceutical data collection devices
- **IR LANs**

## Features

- **Fully compliant to IrDA 1.1 specifications:**
  - 9.6 kb/s to 4 Mb/s operation
  - Excellent nose-to-nose operation
- **Typical link distance > 1.5 m**
- **IEC825-Class 1 eye safe**
- **Wide operating voltage range**
  - 2.7 V to 3.6 V
- **Small module size**
  - 4.0 x 12.2 x 4.9 mm (H x W x D)
- **Complete shutdown**
  - TXD, RXD, PIN diode
- **Low shutdown current**
  - 10 nA typical
- **Adjustable optical power management**
  - Adjustable LED drive-current to maintain link integrity
- **Single Rx data output**
  - FIR select pin switch to FIR
- **Integrated EMI shield**
  - Excellent noise immunity
- **Edge detection input**
  - Prevents the LED from long turn-on time
- **Interface to various super I/O and controller devices**
- **Designed to accommodate light loss with cosmetic window**
- **Only 2 external components are required**

The HSDL-3602 contains a high-speed and high-efficiency 870 nm LED, a silicon PIN diode, and an integrated circuit. The IC contains an LED driver and a receiver providing a single output (RXD) for all data rates supported.

The HSDL-3602 can be completely shut down to achieve very low power consumption. In the shut down mode, the PIN diode is inactive, thus producing very

little photo-current even under very bright ambient light. The HSDL-3602 also incorporates the capability for adjustable optical power. With two programming pins; MODE 0 and MODE 1, the optical power output can be adjusted lower when the nominal desired link distance is one-third or two-third of the full IrDA link.

The HSDL-3602 comes with a front view packaging option (HSDL-3602-007/-037). It has an

integrated shield that helps to ensure low EMI emission and high immunity to EMI field, thus enhancing reliable performance.

**Application Support Information**

The Application Engineering group in Agilent Technologies is available to assist you with the Technical understanding associated with HSDL-3602 infrared transceiver module. You can contact them through your local Agilent sales representatives for additional details.

**Ordering Information**

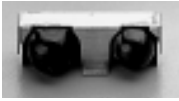
Package Option	Package	Part Number	Standard Package Increment
	Front View	HSDL-3602-007	400
	Front View	HSDL-3602-037	1800

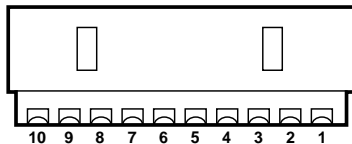

Back view (HSDL-3602-007/-037)

**I/O Pins Configuration Table**

Pin	Description	Symbol
1	Supply Voltage	V <sub>CC</sub>
2	Analog Ground	AGND
3	FIR Select	FIR_SEL
4	Mode 0	MD0
5	Mode 1	MD1
6	No Connection	NC
7	Ground	GND
8	Receiver Data Output	RXD
9	Transmitter Data Output	TXD
10	LED Anode	LEDA

### Transceiver Control Truth Table

Mode 0	Mode 1	FIR_SEL	RX Function	TX Function
1	0	X	Shutdown	Shutdown
0	0	0	SIR	Full Distance Power
0	1	0	SIR	2/3 Distance Power
1	1	0	SIR	1/3 Distance Power
0	0	1	MIR/FIR	Full Distance Power
0	1	1	MIR/FIR	2/3 Distance Power
1	1	1	MIR/FIR	1/3 Distance Power

X = Don't Care

### Transceiver I/O Truth Table

Transceiver Mode	FIR_SEL	Inputs		Outputs	
		TXD	EI	LED	RXD
Active	X	1	X	On	Not Valid
Active	0	0	High <sup>[1]</sup>	Off	Low <sup>[3]</sup>
Active	1	0	High <sup>[2]</sup>	Off	Low <sup>[3]</sup>
Active	X	0	Low	Off	High
Shutdown	X	X <sup>[4]</sup>	Low	Not Valid	Not Valid

X = Don't Care EI = In-Band Infrared Intensity at detector

#### Notes:

1. In-Band EI  $\leq 115.2$  kb/s and FIR\_SEL = 0.
2. In-Band EI  $\geq 0.576$  Mb/s and FIR\_SEL = 1.
3. Logic Low is a pulsed response. The condition is maintained for duration dependent on the pattern and strength of the incident intensity.
4. To maintain low shutdown current, TXD needs to be driven high or low and not left floating.

### Recommended Application Circuit Components

Component	Recommended Value
R1	2.2 $\Omega$ $\pm$ 5%, 0.5 Watt, for 2.7 $\leq$ V <sub>CC</sub> $\leq$ 3.3 V operation 2.7 $\Omega$ $\pm$ 5%, 0.5 Watt, for 3.0 $\leq$ V <sub>CC</sub> $\leq$ 3.6 V operation
CX1 <sup>[5]</sup>	0.47 $\mu$ F $\pm$ 20%, X7R Ceramic
CX2 <sup>[6]</sup>	6.8 $\mu$ F $\pm$ 20%, Tantalum

#### Notes:

5. CX1 must be placed within 0.7 cm of the HSDL-3602 to obtain optimum noise immunity.
6. In "HSDL-3602 Functional Block Diagram" on page 3 it is assumed that V<sub>led</sub> and V<sub>CC</sub> share the same supply voltage and filter capacitors. In case the 2 pins are powered by different supplies CX2 is applicable for V<sub>led</sub> and CX1 for V<sub>CC</sub>. In environments with noisy power supplies, including CX2 on the V<sub>CC</sub> line can enhance supply rejection performance.

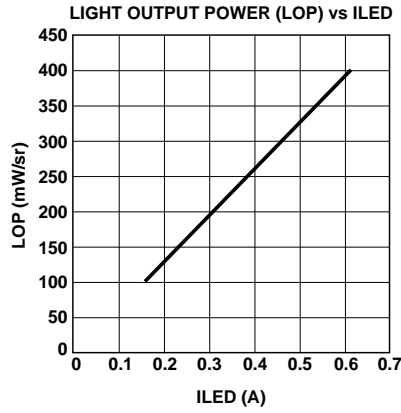
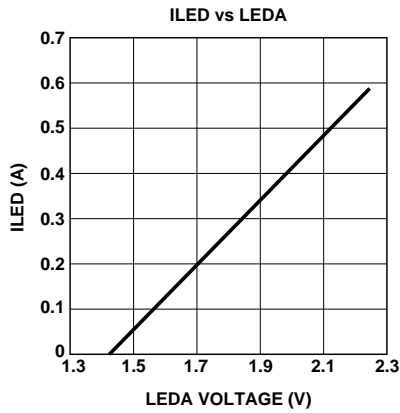

### Marking Information

The HSDL-3602-007/-037 is marked '3602YYWW' on the shield where 'YY' indicates the unit's manufacturing year, and 'WW' refers to the work week in which the unit is tested.

**Caution:** The BiCMOS inherent to the design of this component increases the component's susceptibility to damage from electrostatic discharge (ESD). It is advised that normal static precautions be taken in handling and assembly of this component to prevent damage and/or degradation, which may be induced by ESD.

### Absolute Maximum Ratings<sup>[7]</sup>

Parameter	Symbol	Minimum	Maximum	Unit	Conditions
Storage Temperature	$T_S$	-40	+100	°C	
Operating Temperature	$T_A$	-20	+70	°C	
DC LED Current	$I_{LED} (DC)$		165	mA	
Peak LED Current	$I_{LED} (PK)$		650	mA	$\leq 90 \mu s$ pulse width, $\leq 25\%$ duty cycle
			750	mA	$\leq 2 \mu s$ pulse width, $\leq 10\%$ duty cycle
LED Anode Voltage	$V_{LEDA}$	-0.5	7	V	
Supply Voltage	$V_{CC}$	0	7	V	
Transmitter Data Input Current	$I_{TXD} (DC)$	-12	12	mA	
Receiver Data Output Voltage	$V_O$	-0.5	$V_{CC} + 0.5$	V	$ I_O(RXD)  = 20 \mu A$

**Note:**

7. For implementations where case to ambient thermal resistance  $\leq 50^\circ C/W$ .

### Recommended Operating Conditions

Parameter	Symbol	Minimum	Maximum	Unit	Conditions
Operating Temperature	$T_A$	-20	+70	°C	
Supply Voltage	$V_{CC}$	2.7	3.6	V	
Logic High Input Voltage for TXD, MD0, MD1, and FIR_SEL	$V_{IH}$	$2 V_{CC}/3$	$V_{CC}$	V	
Logic Low Transmitter Input Voltage	$V_{IL}$	0	$V_{CC}/3$	V	
LED (Logic High) Current Pulse Amplitude	$I_{LEDA}$	400	650	mA	
Receiver Signal Rate		0.0024	4	Mb/s	

### Electrical & Optical Specifications

Specifications hold over the Recommended Operating Conditions unless otherwise noted. Unspecified test conditions can be anywhere in their operating range. All typical values are at 25°C and 3.3 V unless otherwise noted.

Parameter	Symbol	Min.	Typ.	Max.	Units	Conditions	
<b>Transceiver</b>							
Supply Current	Shutdown	$I_{CC1}$	10	200	nA	$V_{SD} \geq V_{CC} - 0.5$	
	Idle	$I_{CC2}$	2.5	5	mA	$V_I(TXD) \leq V_{IL}, EI = 0$	
Digital Input Current	Logic Low/High	$I_L/I_H$	-1	1	µA	$0 \leq V_I \leq V_{CC}$	
<b>Transmitter</b>							
Transmitter Radiant Intensity	Logic High Intensity	$E_{IH}$	100	250	400	mW/sr	$V_{IH} = 3.0 V$ $I_{LEDA} = 400 mA$ $\theta_{1/2} \leq 15^\circ$
	Peak Wavelength	$\lambda_p$		875		nm	
	Spectral Line Half Width	$\Delta\lambda_{1/2}$		35		nm	
	Viewing Angle	$2\theta_{1/2}$	30		60	°	
	Optical Pulse Width	$tpw(EI)$	1.5	1.6	1.8	µs	$tpw(TXD) = 1.6 \mu s$ at 115.2 kb/s
			148	217	260	ns	$tpw(TXD) = 217 ns$ at 1.15 Mb/s
			115	125	135	ns	$tpw(TXD) = 125 ns$ at 4.0 Mb/s
	Rise and Fall Times	$t_r(EI), t_f(EI)$			40	ns	$tpw(TXD) = 125 ns$ at 4.0 Mb/s $t_{r/f}(TXD) = 10 ns$
Maximum Optical Pulse Width	$tpw(max)$		20	50	µs	TXD pin stuck high	
LED Anode On State Voltage	$V_{ON}(LEDA)$			2.4	V	$I_{LEDA} = 400 mA, V_I(TXD) \geq V_{IH}$	
LED Anode Off State Leakage Current	$I_{LK}(LEDA)$		1	100	nA	$V_{LEDA} = V_{CC} = 3.6 V,$ $V_I(TXD) \leq V_{IL}$	

## Electrical & Optical Specifications

Specifications hold over the Recommended Operating Conditions unless otherwise noted. Unspecified test conditions can be anywhere in their operating range. All typical values are at 25°C and 3.3 V unless otherwise noted.

Parameter	Symbol	Min.	Typ.	Max.	Units	Conditions
<b>Receiver</b>						
Receiver Data Output Voltage	Logic Low	$V_{OL}$	0	—	0.4	V $I_{OL} = 1.0 \text{ mA}$ , $EI \geq 3.6 \text{ } \mu\text{W}/\text{cm}^2$ , $\theta_{1/2} \leq 15^\circ$
	Logic High	$V_{OH}$	$V_{CC} - 0.2$	—	$V_{CC}$	V $I_{OH} = -20 \text{ } \mu\text{A}$ , $EI \leq 0.3 \text{ } \mu\text{W}/\text{cm}^2$ , $\theta_{1/2} \leq 15^\circ$
	Viewing Angle	$2\theta_{1/2}$	30			°
Logic High Receiver Input Irradiance	$EI_H$		0.0036	500	$\text{mW}/\text{cm}^2$	For in-band signals $\leq 115.2 \text{ kb/s}^{[8]}$
			0.0090	500	$\text{mW}/\text{cm}^2$	0.576 Mb/s $\leq$ in-band signals $\leq 4 \text{ Mb/s}^{[8]}$
Logic Low Receiver Input Irradiance	$EI_L$			0.3	$\mu\text{W}/\text{cm}^2$	For in-band signals <sup>[8]</sup>
Receiver Peak Sensitivity Wavelength	$\lambda_p$		880		nm	
Receiver SIR Pulse Width	tpw (SIR)	1		4.0	$\mu\text{s}$	$\theta_{1/2} \leq 15^\circ^{[10]}$ , $C_L = 10 \text{ pF}$
Receiver MIR Pulse Width	tpw (MIR)	100		500	ns	$\theta_{1/2} \leq 15^\circ^{[11]}$ , $C_L = 10 \text{ pF}$
Receiver FIR Pulse Width	tpw (FIR)	85		165	ns	$\theta_{1/2} \leq 15^\circ^{[12]}$ , $C_L = 10 \text{ pF}$ , $V_{CC} = 3 \text{ to } 3.6 \text{ V}$
					190	ns
Receiver ASK Pulse Width	tpw (ASK)		1		$\mu\text{s}$	500 kHz/50% duty cycle carrier ASK <sup>[13]</sup>
Receiver Latency Time for FIR	$t_L$ (FIR)		40	50	$\mu\text{s}$	
Receiver Latency Time for SIR	$t_L$ (SIR)		20	50	$\mu\text{s}$	
Receiver Rise/Fall Times	$t_{r/f}$ (RXD)		25		ns	
Receiver Wake Up Time	$t_W$			100	$\mu\text{s}$	[14]

### Notes:

8. An in-band optical signal is a pulse/sequence where the peak wavelength,  $\lambda_p$ , is defined as  $850 \leq \lambda_p \leq 900 \text{ nm}$ , and the pulse characteristics are compliant with the IrDA Serial Infrared Physical Layer Link Specification.
9. Logic Low is a pulsed response. The condition is maintained for duration dependent on pattern and strength of the incident intensity.
10. For in-band signals  $\leq 115.2 \text{ kb/s}$  where  $3.6 \text{ } \mu\text{W}/\text{cm}^2 \leq EI \leq 500 \text{ mW}/\text{cm}^2$ .
11. For in-band signals at 1.15 Mb/s where  $9.0 \text{ } \mu\text{W}/\text{cm}^2 \leq EI \leq 500 \text{ mW}/\text{cm}^2$ .
12. For in-band signals of 125 ns pulse width, 4 Mb/s, 4 PPM at recommended 400 mA drive current.
13. Pulse width specified is the pulse width of the second 500 kHz carrier pulse received in a data bit. The first 500 kHz carrier pulse may exceed 2  $\mu\text{s}$  in width, which will not affect correct demodulation of the data stream. An ASK or DASK system using the HSDL-3602 has been shown to correctly receive all data bits for  $9 \text{ } \mu\text{W}/\text{cm}^2 \leq EI \leq 500 \text{ mW}/\text{cm}^2$  incoming signal strength. ASK or DASK should use the FIR channel enabled.
14. The wake up time is the time between the transition from a shutdown state to an active state, and the time when the receiver is active and ready to receive infrared signals.

### TXD "Stuck ON" Protection

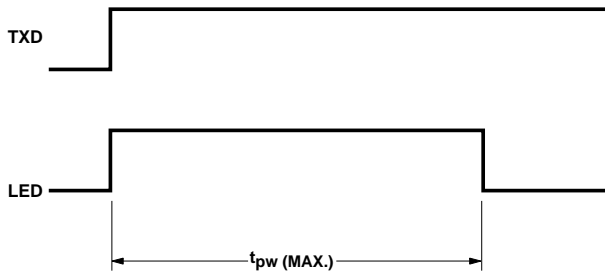

### RXD Output Waveform

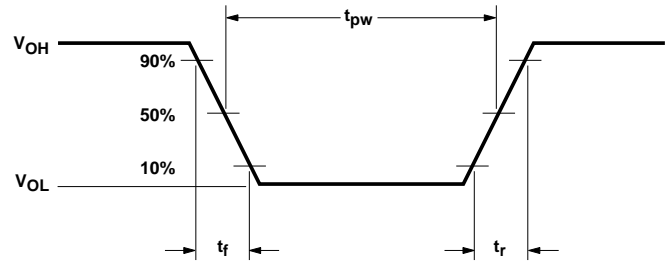

### LED Optical Waveform

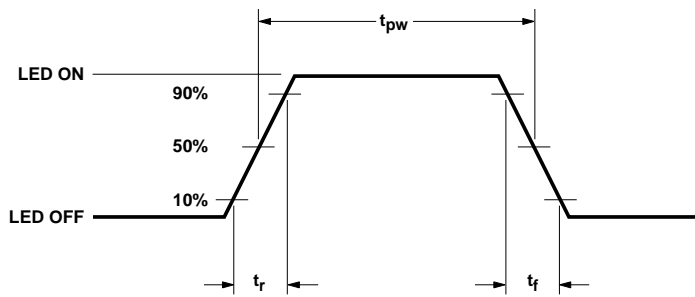

### Receiver Wake Up Time Definition (when MD0 $\neq$ 1 and MD1 $\neq$ 0)

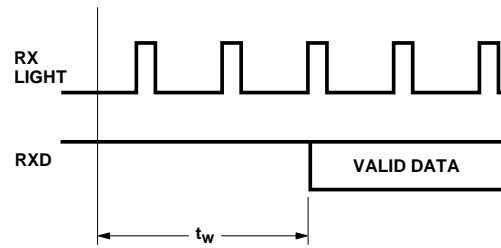



**HSDL-3602-007 and HSDL-3602-037 Package Outline with Dimension and Recommended PC Board Pad Layout**

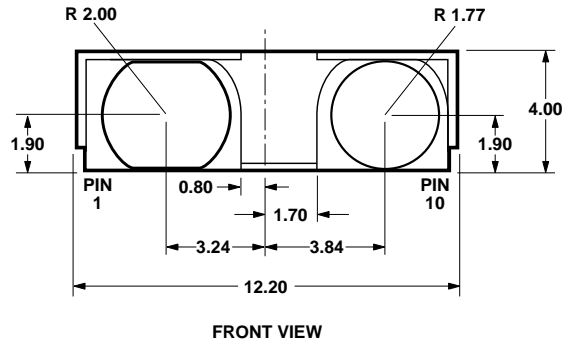
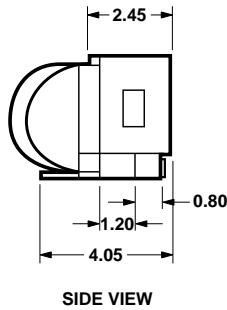
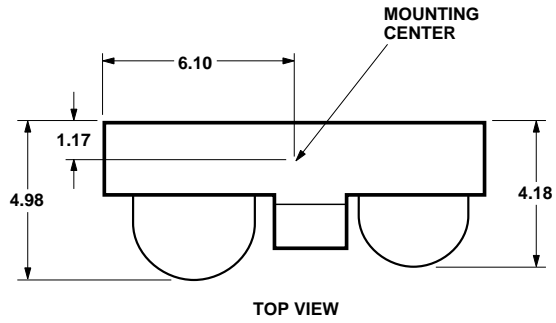

ALL DIMENSIONS IN MILLIMETERS (mm).  
 DIMENSION TOLERANCE IS 0.20 mm  
 UNLESS OTHERWISE SPECIFIED.

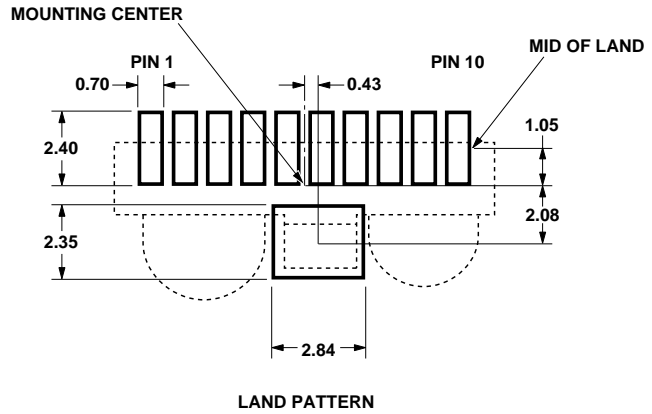
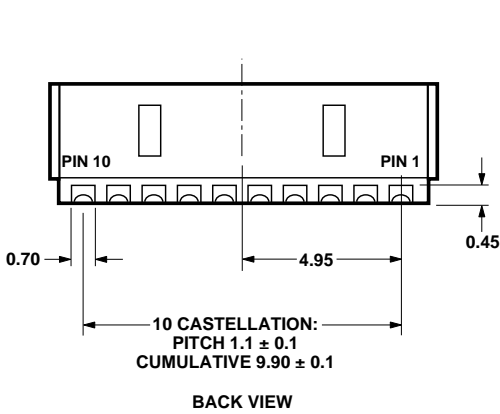

**Tape and Reel Dimensions (HSDL-3602-007, -037)**

ALL DIMENSIONS IN MILLIMETERS (mm)

QUANTITY = 400 PIECES PER REEL (HSDL-3602-007)  
1800 PIECES PER TAPE (HSDL-3602-037)

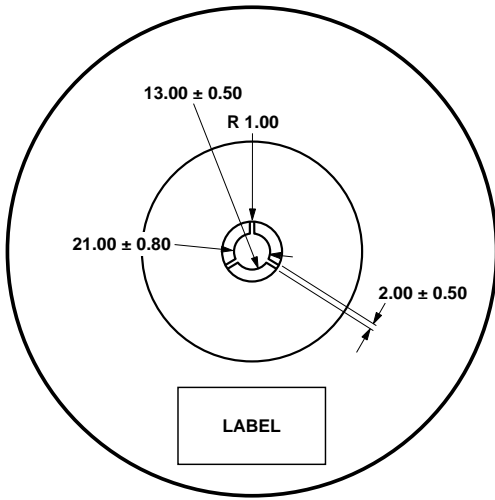

SHAPE AND DIMENSIONS OF REELS

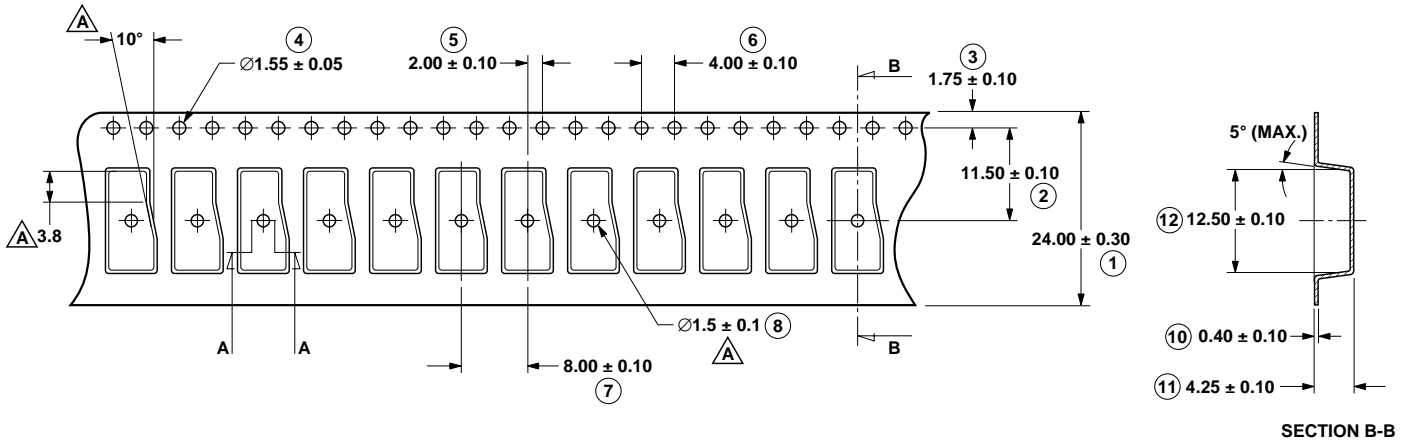
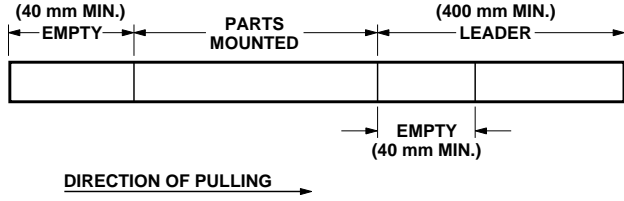

SECTION B-B

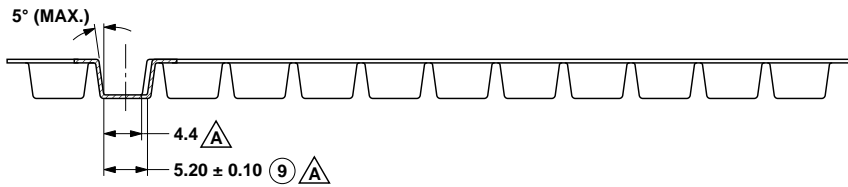

SECTION A-A

**Moisture Proof Packaging**

All HSDL-3602 options are shipped in moisture proof package. Once opened, moisture absorption begins.

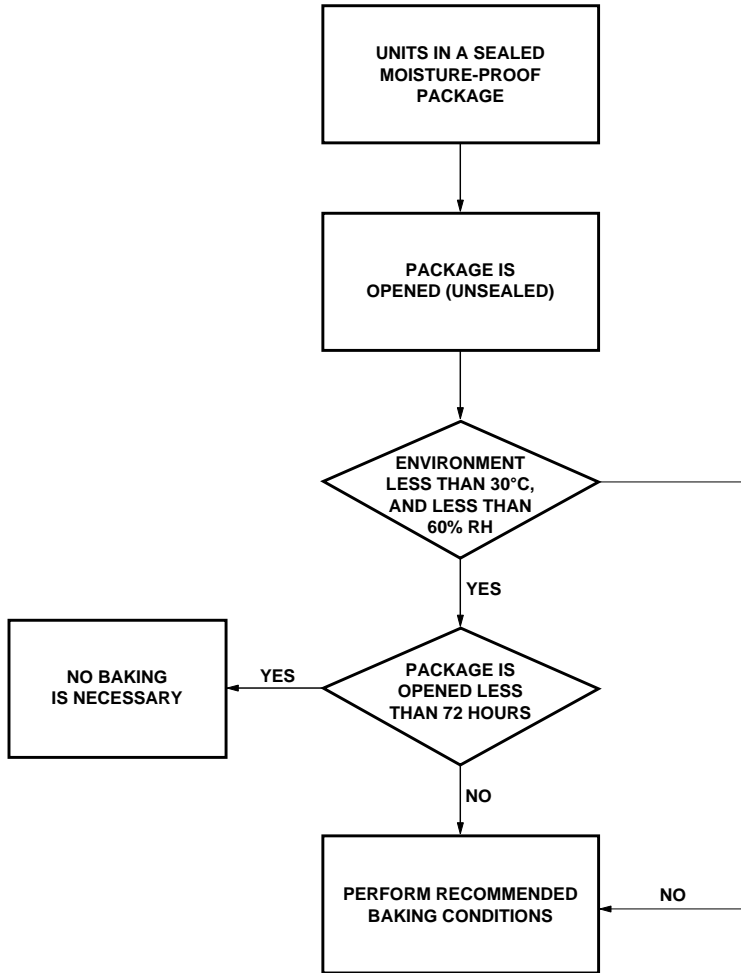

**Baking Conditions**

If the parts are not stored in dry conditions, they must be baked before reflow to prevent damage to the parts.

Package	Temp.	Time
In reels	60°C	≥ 48 hours
In bulk	100°C	≥ 4 hours
	125°C	≥ 2 hours
	150°C	≥ 1 hour

Baking should be done only once.

**Recommended Storage Conditions**

Storage Temperature	10°C to 30°C
Relative Humidity	below 60% RH

**Time from Unsealing to Soldering**

After removal from the bag, the parts should be soldered within 3 days if stored at the recommended storage conditions. If times longer than 72 hours are needed, the parts must be stored in a dry box.

## Reflow Profile

The reflow profile is a straight-line representation of a nominal temperature profile for a convective reflow solder process. The temperature profile is divided into four process zones, each with different  $\Delta T/\Delta \text{time}$  temperature change rates. The  $\Delta T/\Delta \text{time}$  rates are detailed in the following table. The temperatures are measured at the component to printed circuit board connections.

In **process zone P1**, the PC board and HSDL-3602 castellation I/O pins are heated to a temperature of 125°C to activate the flux in the solder paste. The temperature ramp up rate, R1, is limited to 4°C per second to allow for even heating of both the PC board and HSDL-3602 castellation I/O pins.

**Process zone P2** should be of sufficient time duration (> 60 seconds) to dry the solder paste. The temperature is raised to a level just below the liquidus point of the solder, usually 170°C (338°F).

**Process zone P3** is the solder reflow zone. In zone P3, the temperature is quickly raised above the liquidus point of solder to 230°C (446°F) for optimum results. The dwell time above the liquidus point of solder should be between 15 and 90 seconds. It usually takes about 15 seconds to assure proper coalescing of the solder balls into liquid solder and the formation of good solder connections. Beyond a dwell time

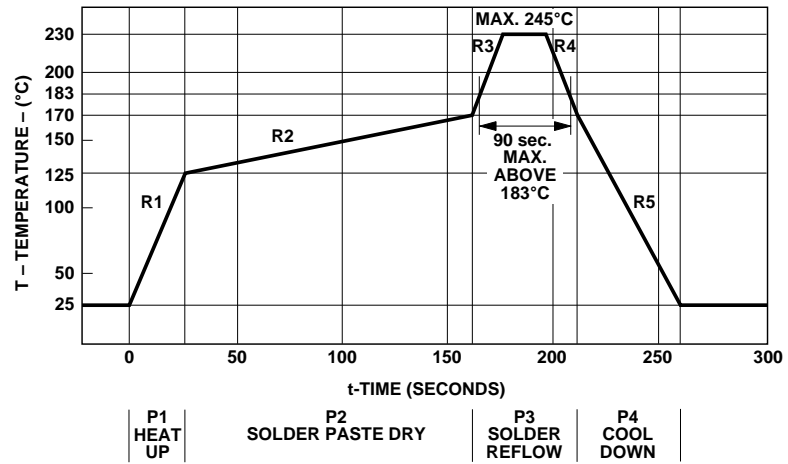

Process Zone	Symbol	$\Delta T$	Maximum $\Delta T/\Delta \text{time}$
Heat Up	P1, R1	25°C to 125°C	4°C/s
Solder Paste Dry	P2, R2	125°C to 170°C	0.5°C/s
Solder Reflow	P3, R3	170°C to 230°C (245°C at 10 seconds max.)	4°C/s
	P3, R4	230°C to 170°C	-4°C/s
Cool Down	P4, R5	170°C to 25°C	-3°C/s

of 90 seconds, the intermetallic growth within the solder connections becomes excessive, resulting in the formation of weak and unreliable connections. The temperature is then rapidly reduced to a point below the solidus temperature of the solder, usually 170°C (338°F), to allow the solder within the connections to freeze solid.

**Process zone P4** is the cool down after solder freeze. The cool down rate, R5, from the liquidus point of the solder to 25°C (77°F) should not exceed -3°C per second maximum. This limitation is necessary to allow the PC board and HSDL-3602 castellation I/O pins to change dimensions evenly, putting minimal stresses on the HSDL-3602 transceiver.

## Appendix A: HSDL-3602-007/-037 SMT Assembly Application Note

### 1.0. Solder Pad, Mask, and Metal Solder Stencil Aperture

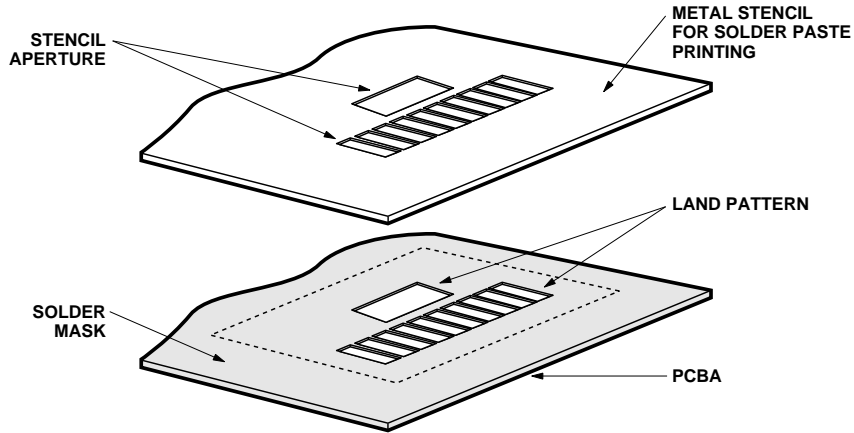

Figure 1. Stencil and PCBA.

### 1.1. Recommended Land Pattern for HSDL-3602-007/-037

Dim.	mm	inches
a	2.40	0.095
b	0.70	0.028
c (pitch)	1.10	0.043
d	2.35	0.093
e	2.80	0.110
f	3.13	0.123
g	4.31	0.170

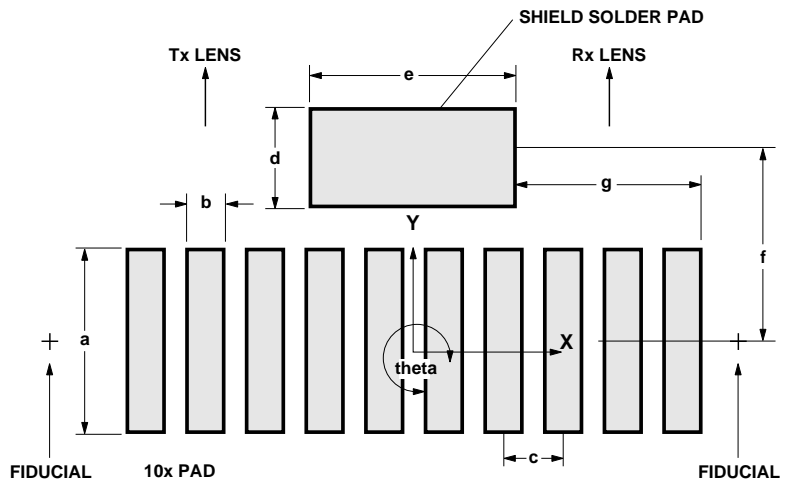

Figure 2. Top view of land pattern.

### 1.2. Adjacent Land Keep-out and Solder Mask Areas

Dim.	mm	inches
h	min. 0.2	min. 0.008
j	13.4	0.528
k	4.7	0.185
l	3.2	0.126

- Adjacent land keep-out is the **maximum space** occupied by the unit relative to the land pattern. There should be no other SMD components within this area.
- “h” is the minimum solder resist strip width required to

avoid solder bridging adjacent pads.

- It is recommended that 2 fiducial cross be placed at mid-length of the pads for unit alignment.

Note : Wet/Liquid Photo-Imagineable solder resist/mask is recommended.

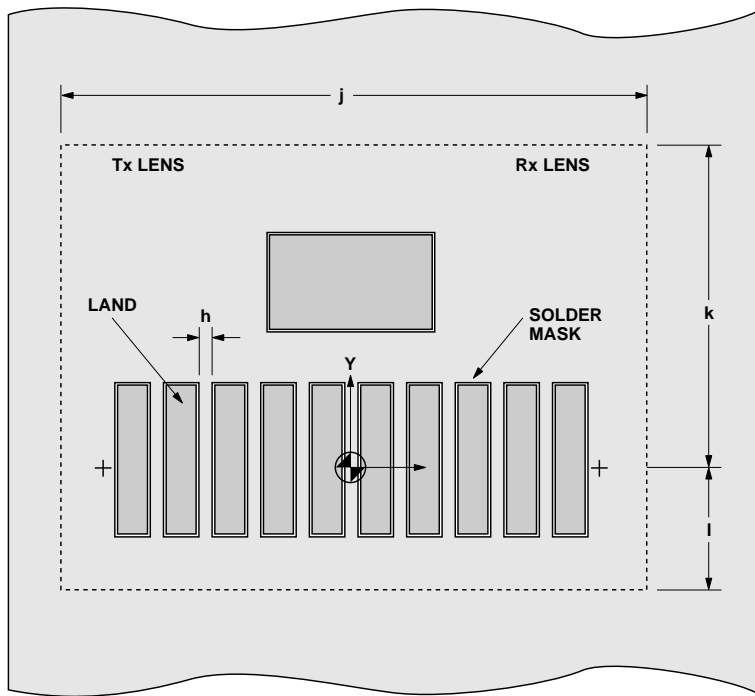

Figure 3. HSDL-3602-007/-037 PCBA-Adjacent land keep-out and solder mask.

**2.0. Recommended solder paste/cream volume for castellation joints**

Based on calculation and experiment, the printed solder paste volume required per castellation pad is 0.30 cubic mm (based on either no-clean or aqueous solder cream types with typically 60 to 65% solid content by volume).

**2.1. Recommended Metal Solder Stencil Aperture**

It is recommended that only 0.152 mm (0.006 inches) or 0.127 mm (0.005 inches) thick stencil be used for solder paste printing. This is to ensure adequate printed solder paste volume and no shorting. The following combination of metal stencil aperture and metal stencil thickness should be used:

See Figure 4

t, nominal stencil thickness		l, length of aperture	
mm	inches	mm	inches
0.152	0.006	2.8 ± 0.05	0.110 ± 0.002
0.127	0.005	3.4 ± 0.05	0.134 ± 0.002

w, the width of aperture is fixed at 0.70 mm (0.028 inches)

Aperture opening for shield pad is 2.8 mm x 2.35 mm as per land dimension.

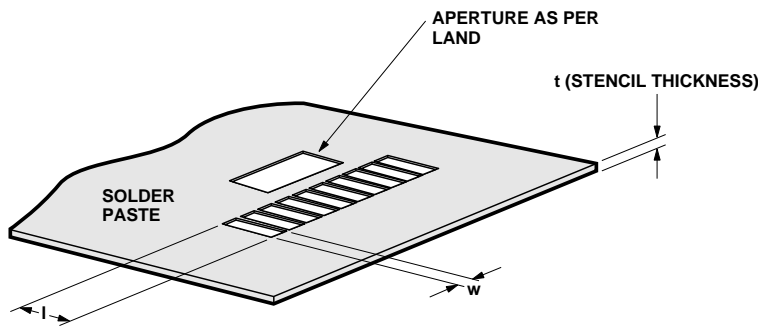

Figure 4. Solder paste stencil aperture.

**3.0. Pick and Place Misalignment Tolerance and Product Self-Alignment after Solder Reflow**

If the printed solder paste volume is adequate, the unit will self-align in the X-direction after solder reflow. Units should be properly reflowed in IR Hot Air convection oven using the recommended reflow profile. The direction of board travel does not matter.

**Allowable Misalignment Tolerance**

X-direction	≤ 0.2 mm (0.008 inches)
Theta-direction	± 2 degrees

### 3.1. Tolerance for X-axis Alignment of Castellations

Misalignment of castellations to the land pad should not exceed 0.2 mm or approximately half the width of the castellation during placement of the unit. The castellations will completely self-align to the pads during solder reflow as seen in the pictures below.



Picture 1. Castellations misaligned to land pads in X-axis before reflow.

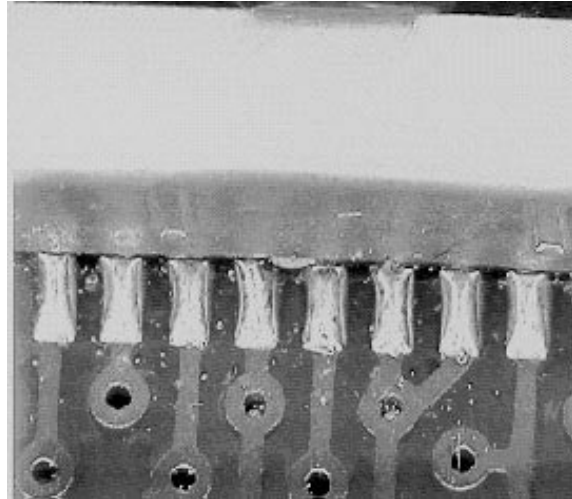

Picture 2. Castellations self-align to land pads after reflow.

### 3.2. Tolerance for Rotational (Theta) Misalignment

Units when mounted should not be rotated more than  $\pm 2$  degrees with reference to center X-Y as specified in Figure 2. Pictures 3 and 4 show units before and after reflow. Units with a Theta misalignment of more than 2 degrees do not completely self-align after reflow. Units with  $\pm 2$  degree rotational or Theta misalignment self-aligned completely after solder reflow.

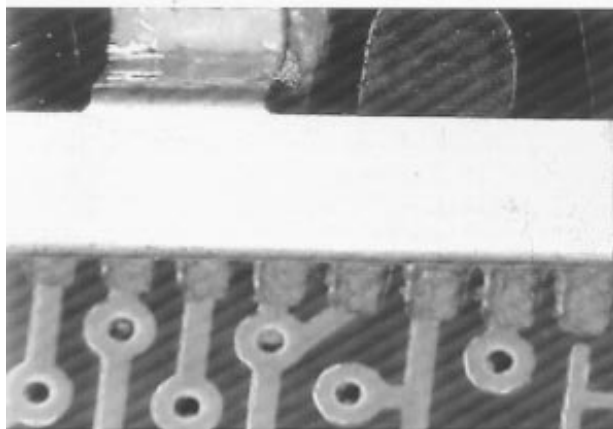

Picture 3. Unit is rotated before reflow.



Picture 4. Unit self-aligns after reflow.



### 3.3. Y-axis Misalignment of Castellation

In the Y-direction, the unit does not self-align after solder reflow. It is recommended that the unit be placed in line with the fiducial mark (mid-length of land pad). This will enable sufficient land length (minimum of 1/2 land length) to form a good joint. See Figure 5.

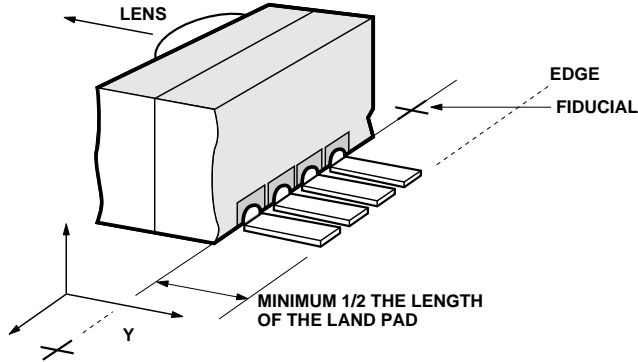
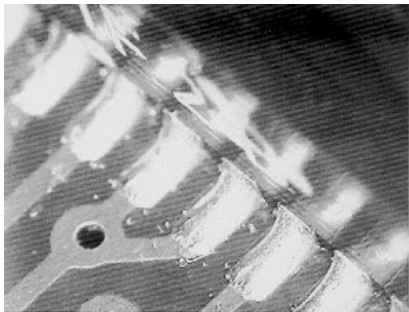

Figure 5. Section of a castellation in Y-axis.

### 3.4. Example of Good HSDL-3602-007/-037 Castellation Solder Joints

This joint is formed when the printed solder paste volume is adequate, i.e., 0.30 cubic mm and reflowed properly. It should be reflowed in IR Hot-air convection reflow oven. Direction of board travel does not matter.



Picture 5. Good solder joint.

### 4.0. Solder Volume Evaluation and Calculation

Geometry of an HSDL-3602-007/-037 solder fillet.

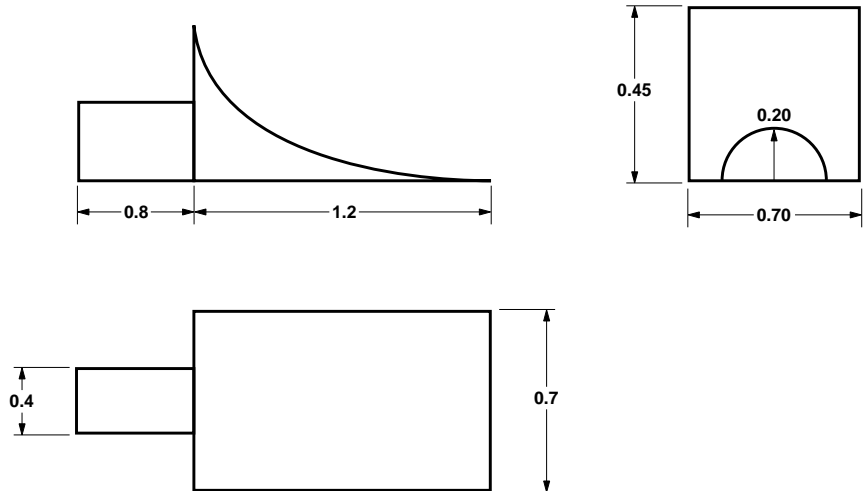

**Appendix B: General Application Guide for the HSDL-3602 Infrared IrDA® Compliant 4 Mb/s Transceiver Description**

The HSDL-3602 wide voltage operating range infrared transceiver is a low-cost and small form factor that is designed to address the mobile computing market such as notebooks, printers and LAN access as well as small embedded mobile products such as digital cameras, cellular phones, and PDAs. It is fully compliant to IrDA 1.1 specification up to 4 Mb/s, and supports HP-SIR, Sharp ASK, and TV Remote modes. The design of the HSDL-3602 also includes the following unique features:

- Low passive component count.
- Adjustable Optical Power Management (full, 2/3, 1/3 power).
- Shutdown mode for low power consumption requirement.
- Single-receive output for all data rates.

**Adjustable Optical Power Management**

The HSDL-3602 transmitter offers user-adjustable optical power levels. The use of two logic-level mode-select input pins, MODE 0 and MODE 1, offers shutdown mode as well as three transmit power levels as shown in the following Table. The power levels

are setup to correspond nominally to maximum, two-third, and one-third of the transmission distance. This unique feature allows lower optical power to be transmitted at shorter link distances to reduce power consumption.

MODE	MODE 1	Transmitter
1	0	Shutdown
0	0	Full Power
0	1	2/3 Power
1	1	1/3 Power

There are 2 basic means to adjust the optical power of the HSDL-3602:

**Dynamic:** This implementation enables the transceiver pair to adjust their transmitter power according to the link distance. However, this requires the IrDA protocol stack (mainly the IrLAP layer) to be modified. Please contact Agilent Application group for further details.

**Static:** Pre-program the ROM BIOS of the system (e.g. notebook PC, digital camera, cell phones, or PDA) to allow the end user to select the desired optical power during the system setup stage.

**Selection of Resistor R1**

Resistor R1 should be selected to provide the appropriate peak pulse LED current over different ranges of Vcc. The recommended R1 for the voltage range of 2.7 V to 3.3 V is 2.2 Ω while for 3.0 V to 3.6 V is 2.7 Ω. The HSDL-3602 typically provides 250 mW/sr of intensity at the recommended minimum peak pulse LED current of 400 mA.

**Interface to Recommended I/O chips**

The HSDL-3602’s TXD data input is buffered to allow for CMOS drive levels. No peaking circuit or capacitor is required.

Data rate from 9.6 kb/s up to 4 Mb/s is available at the RXD pin. The FIR\_SEL pin selects the data rate that is receivable through RXD. Data rates up to 115.2 kb/s can be received if FIR\_SEL is set to logic low. Data rates up to 4 Mb/s can be received if FIR\_SEL is set to logic high. Software driver is necessary to program the FIR\_SEL to low or high at a given data rate.

4 Mb/s IR link distance of greater than 1.5 meters have been demonstrated using typical HSDL-3602 units with National Semiconductor’s PC87109 3 V Endec and Super I/Os, and the SMC Super I/O chips.

**(A) National Semiconductor Super I/O and Infrared Controller**

For National Semiconductor Super I/O and Infrared Controller chips, IR link can be realized with the following connections:

- Connect IRTX of the National Super I/O or IR Controller to TXD (pin 9) of the HSDL-3602.
- Connect IRRX1 of the National Super I/O or IR Controller to RXD (pin 8) of the HSDL-3602.
- Connect IRSLO of the National Super I/O or IR Controller to FIR\_SEL (pin 3) of the HSDL-3602.

Please refer to the table below for the IR pin assignments for the National Super I/O and IR Controllers that support IrDA 1.1 up to 4 Mb/s:

	IRTX	IRRX1	IRSLO
PC97/87338VJG	63	65	66
PC87308VUL	81	80	79
PC87108AVHG	39	38	37
PC87109VBE	15	16	14

Please refer to the National Semiconductor data sheets and application notes for updated information.

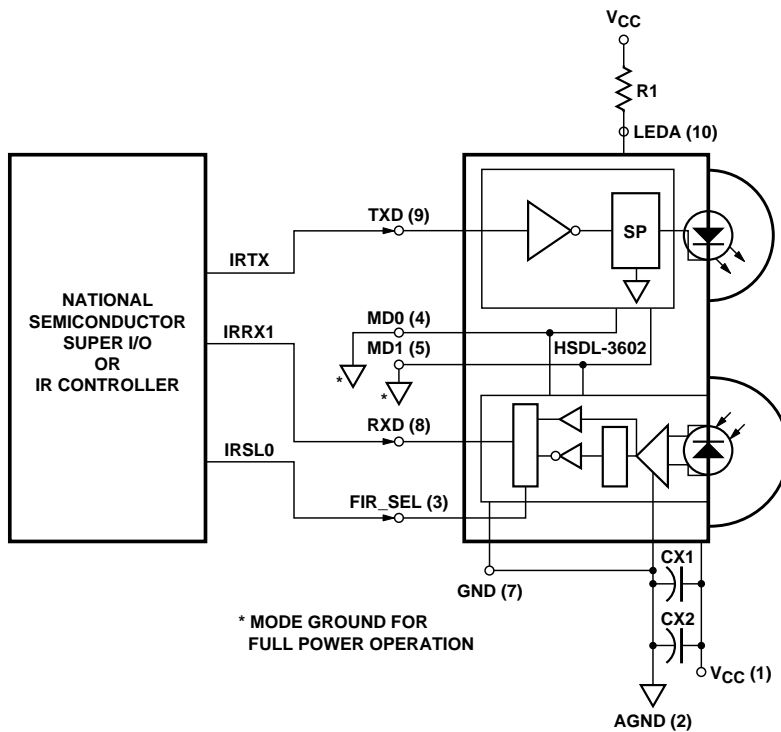

**(B) HSDL-3602 Interoperability with National Semiconductor PC97338VJG SIO Evaluation Report Introduction**

The objective of this report is to demonstrate the interoperability of the HSDL-3602 IR transceiver IR module as wireless communication ports at the speed of 2.4 kb/s - 4 Mb/s with NS's PC97338VJG Super I/O under typical operating conditions.

**Test Procedures**

(1) Two PC97338VJG evaluation boards were connected to the ISA Bus of two PCs (Pentium 200 MHz) running

Microsoft's DOS operating system. One system with an HSDL-3602 IR transceiver connected to the PC97338VJG evaluation board will act as the master device. Another system with an HSDL-3602 IR transceiver connected to the PC97338VJG will act as the slave device (i.e. Device Under Test).

(2) The test software used in this interoperability test is provided by National Semiconductor. A file size of

1.7M byte from the master device, with the PC97338VJG performing the framing, encoding is transmitted to the slave device. The slave device, with the PC97338VJG performing the decoding, and CRC checksum, will receive the file. The file is then checked for error by comparing the received file with the original file using the DOS "fc" command.

(3) The link distance is measured by adjusting the distance between the master and slave for errorless data communications.

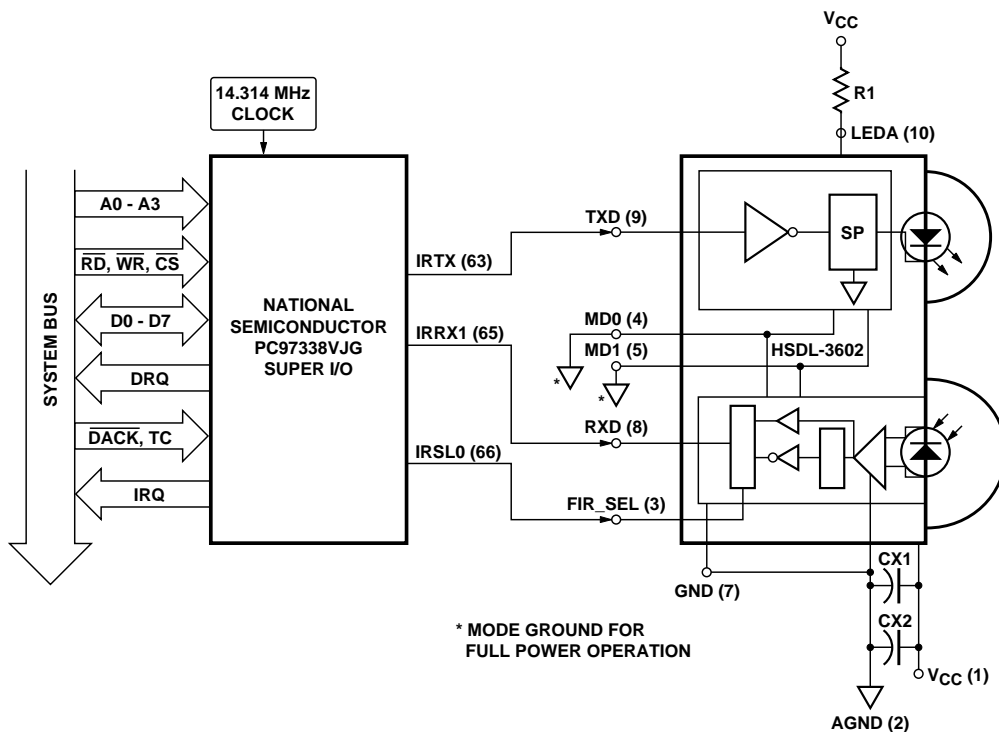

**HSDL-3602 Interoperability with NS PC97338 Report**

**(i) Test Conditions**

$V_{CC} = 3.0 - 3.6 V$   
 $R_{LED} = 2.7 \Omega$   
 Optical transmitter pulse width = 125 ns  
 Mode set to full power

**(ii) Test Result**

The interoperability test results show that HSDL-3602 IR transceiver can operate  $\geq 1.5$  meter link distance from 3 V to 3.6 V with NS's PC97338 at any IrDA 1.1 data rate without error.

**(C) Standard Micro System Corporation (SMC) Super and Ultra I/O Controllers**

For SMC Super and Ultra I/O Controller chips, IR link can be realized with the following connections:

- Connect IRTX of the SMC Super or Ultra I/O Controller to TXD (pin 9) of the HSDL-3602.

- Connect IRRX of the SMC Super or Ultra I/O Controller to RXD (pin 8) of the HSDL-3602.
- Connect IRMODE of the Super or Ultra I/O Controller to FIR\_SEL (pin 3) of the HSDL-3602.

Please refer to the table below for the IR pin assignments for the SMC Super or Ultra I/O Controllers that support IrDA 1.1 up to 4Mb/s:

	IRTX	IRRX	IRMODE
FDC37C669FR	89	88	23
FDC37N769	87	86	21
FDC37C957/8FR	204	203	145 or 190

**HSDL-3602 Interoperability with SMC's Super I/O or IR Controller**

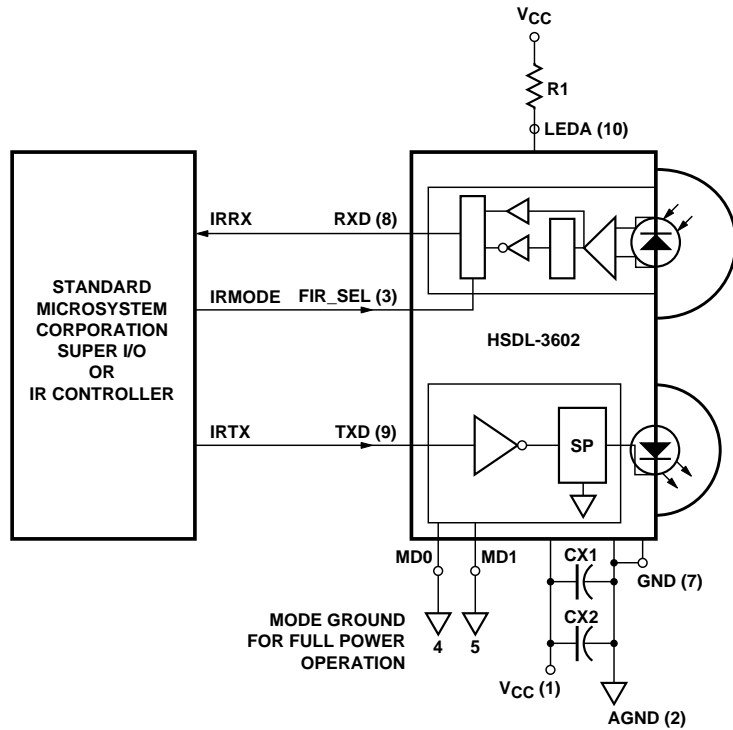

**HSDL-3602 Interoperability with SMC 669/769 Report**

**(i) Test Conditions**

Vcc = 3.0 – 3.6 V  
 RLED = 2.2 Ω  
 Optical transmitter pulse width = 125 ns  
 Mode set to full power

**(ii) Test Result**

The interoperability test results show that HSDL-3602 IR transceiver can operate ≥ 1.5 meter link distance from 3 V to 3.6 V with SMC 669/769 at any IrDA 1.1 data rate without error.

**Appendix C: Optical Port Dimensions for HSDL-3602:**

To ensure IrDA compliance, some constraints on the height and width of the window exist. The minimum dimensions ensure that the IrDA cone angles are met without vignetting. The maximum dimensions minimize the effects of stray light. The minimum size corresponds to a cone angle of 30° and the maximum size corresponds to a cone angle of 60°.

In the figure below, X is the width of the window, Y is the

height of the window and Z is the distance from the HSDL-3602 to the back of the window. The distance from the center of the LED lens to the center of the photodiode lens, K, is 7.08mm. The equations for computing the window dimensions are as follows:

$$X = K + 2*(Z+D)*\tan A$$

$$Y = 2*(Z+D)*\tan A$$

The above equations assume that the thickness of the window is negligible compared to the distance of the module from the back of the window (Z). If they are com-

parable, Z' replaces Z in the above equation. Z' is defined as  $Z' = Z + t/n$

where 't' is the thickness of the window and 'n' is the refractive index of the window material.

The depth of the LED image inside the HSDL-3602, D, is 8mm. 'A' is the required half angle for viewing. For IrDA compliance, the minimum is 15° and the maximum is 30°. Assuming the thickness of the window to be negligible, the equations result in the following tables and graphs:

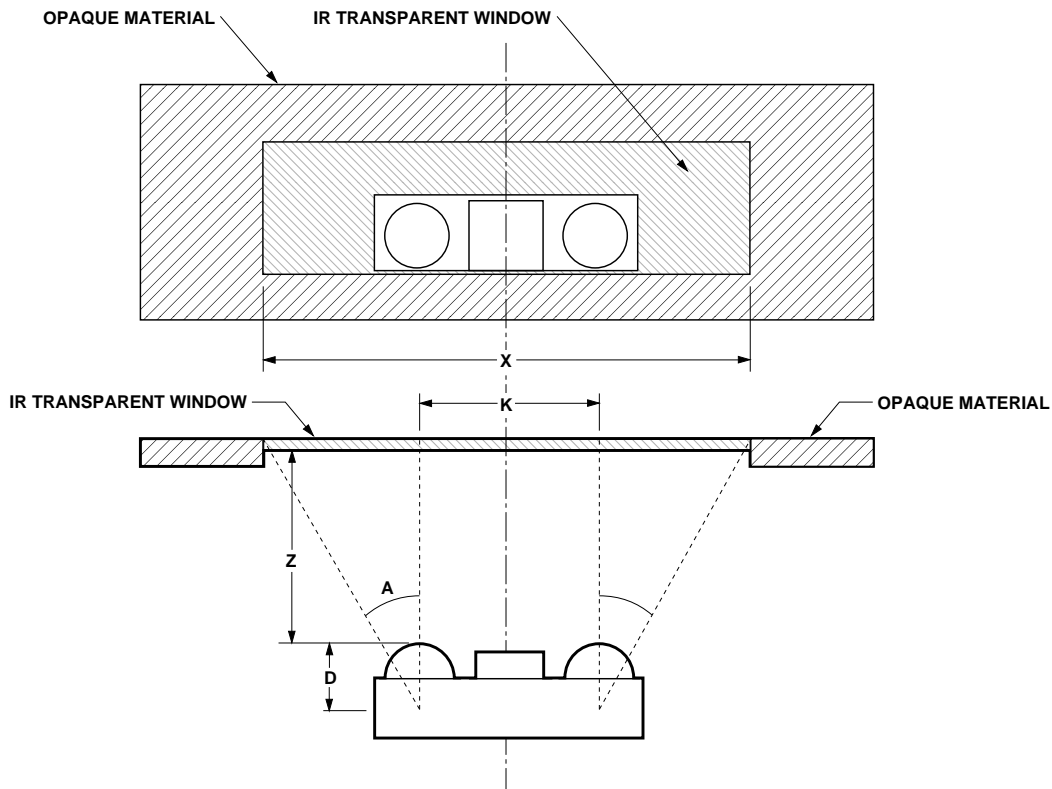

Module Depth, (z) mm	Aperture Width (x, mm)		Aperture height (y, mm)	
	max.	min.	max.	min.
0	16.318	11.367	9.238	4.287
1	17.472	11.903	10.392	4.823
2	18.627	12.439	11.547	5.359
3	19.782	12.975	12.702	5.895
4	20.936	13.511	13.856	6.431
5	22.091	14.047	15.011	6.967
6	23.246	14.583	16.166	7.503
7	24.401	15.118	17.321	8.038
8	25.555	15.654	18.475	8.574
9	26.710	16.190	19.630	9.110

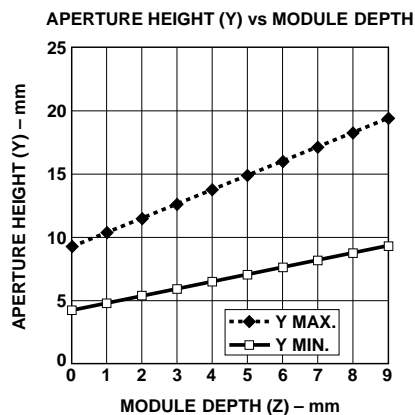
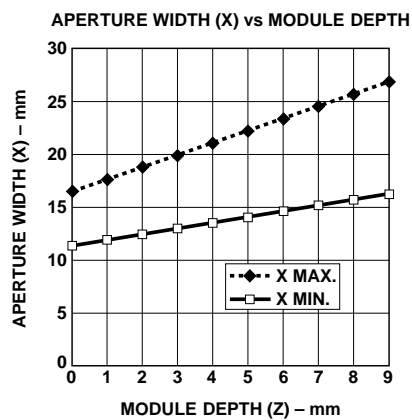

**Window Material**

Almost any plastic material will work as a window material. Polycarbonate is recommended. The surface finish of the plastic should be smooth, without any texture. An IR filter dye may be used in the window to make it look black to the eye, but the total optical loss of the window should be 10 percent or less for best optical performance. Light loss should be measured at 875 nm.

**Shape of the Window**

From an optics standpoint, the window should be flat. This

ensures that the window will not alter either the radiation pattern of the LED, or the receive pattern of the photodiode.

If the window must be curved for mechanical or industrial design reasons, place the same curve on the back side of the window that has an identical radius as the front side. While this will not completely eliminate the lens effect of the front curved surface, it will significantly reduce the effects. The amount of change in the radiation pattern is dependent upon the material chosen for the

window, the radius of the front and back curves, and the distance from the back surface to the transceiver. Once these items are known, a lens design can be made which will eliminate the effect of the front surface curve.

The following drawings show the effects of a curved window on the radiation pattern. In all cases, the center thickness of the window is 1.5 mm, the window is made of polycarbonate plastic, and the distance from the transceiver to the back surface of the window is 3 mm.

**Flat Window**  
(First choice)

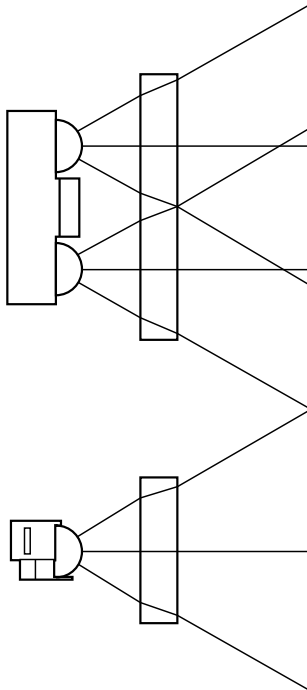

**Curved Front and Back**  
(Second choice)

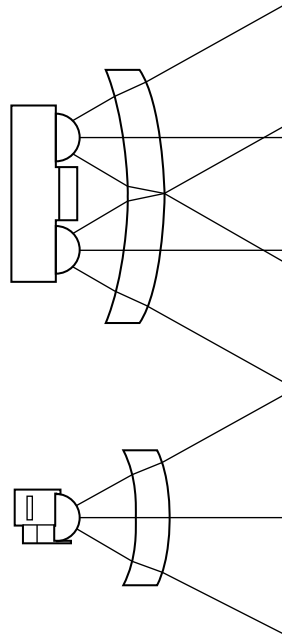

**Curved Front, Flat Back**  
(Do not use)

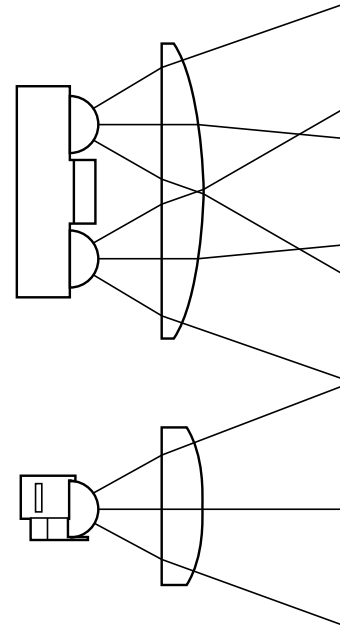



**[www.agilent.com/semiconductors](http://www.agilent.com/semiconductors)**

For product information and a complete list of distributors, please go to our web site.

For technical assistance call:

Americas/Canada: +1 (800) 235-0312 or  
(408) 654-8675

Europe: +49 (0) 6441 92460

China: 10800 650 0017

Hong Kong: (+65) 6271 2451

India, Australia, New Zealand: (+65) 6271 2394

Japan: (+81 3) 3335-8152(Domestic/International), or 0120-61-1280(Domestic Only)

Korea: (+65) 6271 2194

Malaysia, Singapore: (+65) 6271 2054

Taiwan: (+65) 6271 2654

Data subject to change.

Copyright © 2002 Agilent Technologies, Inc.

Obsoletes 5988-5836EN

December 3, 2002

5988-8422EN



**Agilent Technologies**