

Description

Single and multipole magnetic circuit breakers with trip-free mechanism and toggle actuation. A choice of fast magnetic or hydraulically delayed switching characteristics (S-type MO or HM CBE to EN 60934) ensures suitability for a wide range of applications. Industry standard dimensions and panel mounting. Options include auxiliary changeover contacts. Low temperature sensitivity at rated load. Approved to CBE standard EN 60934 (IEC 60934): S-type HM CBE.

Typical applications

Communications systems, power supplies, switchgear and controlgear industrial process measurement and control.

Standard current ratings and typical internal resistance values

Current rating (A)	Internal resistance (Ω) per pole ± 10%	
	K1, M1, T1	K2, M2, T2
1	1.04	1.03
2	0.22	0.22
3	0.11	0,11
4	0.06	0.06
5	0.04	0.04
6	0.03	0.03
8	0.02	0.02
10	< 0.02	< 0.02
12	< 0.02	< 0.02
15	< 0.02	< 0.02
16	< 0.02	< 0.02
20	< 0.02	< 0.02
24	< 0.02	< 0.02
25	< 0.02	< 0.02
30	< 0.02	< 0.02
35	< 0.02	-
40	< 0.01	-
45	< 0.01	-
50	< 0.01	-

Approvals

Authority	Voltage ratings	Current ratings
1) VDE (EN 60934)	DC 80 V	1...50 A
	AC 240 V	1...30 A
	3 AC 415 V	1...30 A 1- and multipole
1) UL 1077	DC 80 V	1...50 A
	AC 250 V	1...50 A
	AC 125 V / 250 V	1...50 A 1- and multipole
1) Ignition protected (UL 10 77 + UL 1500)	DC 65 V	1...50 A 1- and 2-pole
	DC 32 V (ABYC)	1...50 A 1- and 2-pole
	AC 125 V/250 V (ABYC)	1...30 A 2-pole
1) UL 489A	DC 250 V (ABYC)	1...30 A 1-pole
	DC 80 V	1...50 A 1- and 2-pole
1) CCC	DC 80 V	1...50 A 1- and 2-pole
	AC 240 V/415 V	1...30 A 1...3-pole

1) Depending on the circuit breaker configuration

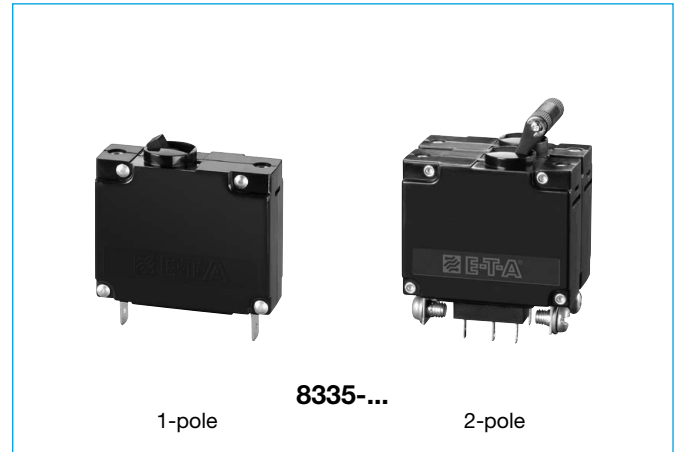

1-pole

8335-...

2-pole

Technical data

For further details please see chapter: Technical Information

Voltage rating	3 AC 415 V; AC 240 V (50/60 Hz); DC 80 V		
Current ratings	1...50 A 1- and multipole		
Auxiliary circuit	AC 250 V	5 A	
	DC 80 V	0,5 A	
Typical life	3 AC 415 V, AC 240 V: 1...30 A 6,000 operations at 1 x I _N , inductive 10,000 operations at 1 x I _N , resistive		
	DC 80 V: 1...50 A	10,000 operations at 1 x I _N , inductive 10,000 operations at 1 x I _N , resistive	
Ambient temperature	-40 °C...85 °C		
Insulation co-ordination (IEC 60664)	rated impulse withstand voltage	pollution degree	
	2.5 kV	2	
	reinforced insulation in operating area		
Dielectric strength	operating area	test voltage AC 3,000 V	
	Line to Load	test voltage AC 1,500 V	
	pole to pole (2- and 3-pole)	test voltage AC 1,500 V	
	main to auxiliary circuit	test voltage AC 1,500 V	
Insulation resistance	> 100 MΩ (DC 500 V)		
Interrupting capacity I _{cn}	1,500 A (AC, DC)		
Interrupting capacity (UL 1077)	Standard	Ignition protected (UL 1500)	
DC 80 V	1- + 2-pole	1...30 A 3,000 A	U1a ---
DC 80 V	1- + 2-pole	1...50 A 1,500 A	U1a ---
DC 65 V	1- + 2-pole	1...50 A 3,000 A	U1a U1a
DC 32 V	1- + 2-pole	1...50 A 5,000 A	U3 U3
AC 250 V	1- + 2-pole	1...30 A 5,000 A	C1A ---
		3,000 A	U1a U1a
AC 250 V	1- + 2-pole	1...50 A 1,000 A	U1a ---
AC125/250 V	2-pole	1...30 A 3,000 A	U1a U1a
AC125/250 V	2-pole	1...50 A 2,000 A	U3 ---
3 AC 250 V	3-pole	1...30 A 5,000 A	U1a ---
3 AC 250 V	3-pole	1...50 A 1,000 A	U3 ---
Interrupting capacity (UL 489A) 1,500 A			
Degree of protection (IEC 60529/DIN 40050)	operating area IP40 terminal area IP00		
Vibration	all mounting positions: 10 g (57-2000 Hz) ± 0.76 mm (10-57 Hz) at 0.9 x I _N to IEC 60068-2-6, test Fc 10 frequency cycles/axis		
Shock	all shock directions 100 g (11 ms) at 0.8 x I _N to IEC 60068-2-27, test Ea		
Corrosion	96 hours at 5% salt mist, to IEC 60068-2-11, test Ka		
Humidity	240 hours at 95 % RH to IEC 60068-2-78, test Cab		
Mass	approx. 65 g per pole		

Ordering information (EN60934/UL 1077/CCC)

Type No.	8335
Mounting	F flange mounting
Configuration	1 with mounting nuts 6-32 UNC 4 with mounting nuts M3 9 snap-in frame
Number of poles	1 single pole protected 2 two pole protected 3 three pole protected
Panel hardware	0 without panel hardware
Terminal design (main contact)	K4 screw terminals with metric thread, M5 K5 screw terminals with 8-32UNC K6 screw terminals with 10-32UNF I4 screw terminals with metric thread, M5 (busbar connection) I5 screw terminals with 8-32UNC (busbar connection) I6 screw terminals with 10-32UNF (busbar connection) P1 blade terminals DIN 46244-A6.3x0.8 $I_N \leq 30$ A
Characteristic curves	Characteristic curve K, short delay: K1 DC trip time at $2 \times I_N$: 0.13-1.2 s K2 AC 60/50 Hz trip time at $2 \times I_N$: 0.13-1.3 s Characteristic curve M, medium delay: M1 DC trip time at $2 \times I_N$: 0.6-20 s M2 AC 60/50 Hz trip time at $2 \times I_N$: 2.2-20 s Characteristic curve T, long delay: T1 DC trip time at $2 \times I_N$: 9-60 s T2 AC 60/50 Hz trip time at $2 \times I_N$: 10-90 s
Actuator colour / design	A black, long toggle B white, long toggle K black, short toggle L white, short toggle W black, rocker (only 1-pole) 1 black – long toggle (reduced) 2 white – long toggle (reduced) 3 black – rocker (reduced) Z black – actuator slot (only 1-pole)
Marking on actuator	8 I-O; ON-OFF, I_N on actuator, vertical P I-O; ON-OFF, I_N horizontal (rocker only)
Auxiliary contacts	00 without auxiliary contacts K2 auxiliary contacts, tin-plated on one pole only
Auxiliary contact function	0 without 4 1 change over contact
Auxiliary contact terminal design	0 without 2 blade terminal 2.8-0.5 mm
Approvals (optional)	0 standard (EN 60934/UL 1077/CCC) I ignition protected UL 1500 V UL 1077
Current ratings	1...50 A DC 1...50 A AC
8335 - F 1 1 0 - P1 M1 - A 8 K2 4 2 I - 30 A	ordering example

Ordering information (EN60934/UL 489A/CCC)

Type No.	8335
Mounting	F flange mounting
Configuration	1 with mounting nuts 6-32 UNC 4 with mounting nuts M3 9 snap-in frame
Number of poles	1 single pole protected 2 two pole protected
Panel hardware	0 without panel hardware
Terminal design (main contact)	K4 screw terminals with metric thread, M5 K5 screw terminals with 8-32UNC K6 screw terminals with 10-32UNF I4 screw terminals with metric thread, M5 (busbar connection) I5 screw terminals with 8-32UNC (busbar connection) I6 screw terminals with 10-32UNF (busbar connection) P1 blade terminals DIN 46244-A6.3x0.8 $I_N \leq 30$ A
Characteristic curves	K1 short delay 100 - 125 % M1 medium delay 100 - 125 % T1 long delay 100 - 125 %
Actuator colour / design	A black, long toggle B white, long toggle K black, short toggle (only 1-pole) L white, short toggle (only 1-pole) W black, rocker (only 1-pole) 1 black – long toggle (reduced) 2 white – long toggle (reduced) 3 black – rocker (reduced) Z black – actuator slot (only 1-pole)
Marking on actuator	8 I-O; ON-OFF, I_N on actuator, vertical P I-O; ON-OFF, I_N horizontal (rocker only)
Auxiliary contacts	00 without auxiliary contacts K2 symmetric
Auxiliary contact function	0 without 4 1 change over contact
Auxiliary contact terminal design	0 without 2 blade terminal 2.8-0.5 mm
Approvals	U UL 489A
Current ratings	1...50 A
8335 - F 4 1 0 - P1 M1 - A 8 K2 4 2 U - 1 A	ordering example

Dimensions

**Flange mounting - F
actuator long A, B**

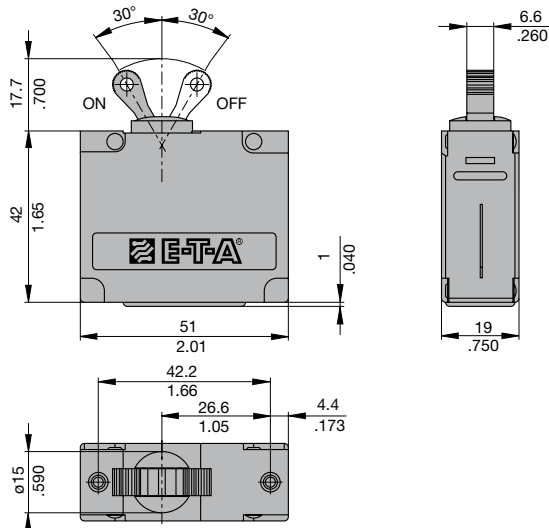

actuator short K, L

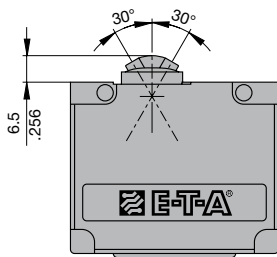

actuator slot Z

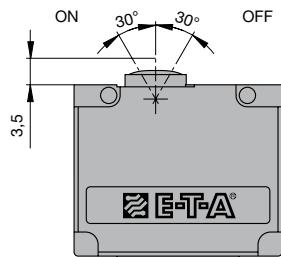

Flange mounting F1 or F4

number of poles 1 to 2
1 2

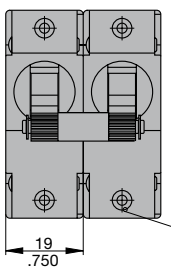

mounting thread M3 or 6-32 UNC
max. insertion depth 4.5 mm/.177 in.
to the top edge
max. tightening torque 0.5 Nm

**Cut-out dimensions
recommended panel thickness 1 - 2.5 mm**

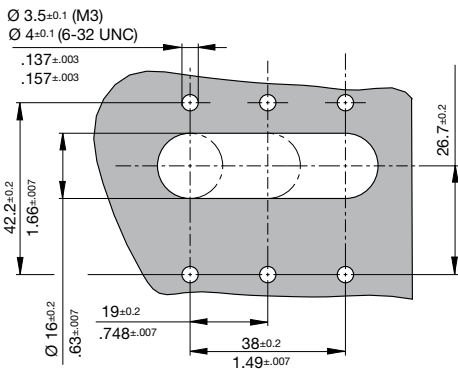

Flange mounting -F9 (snap-in frame black)

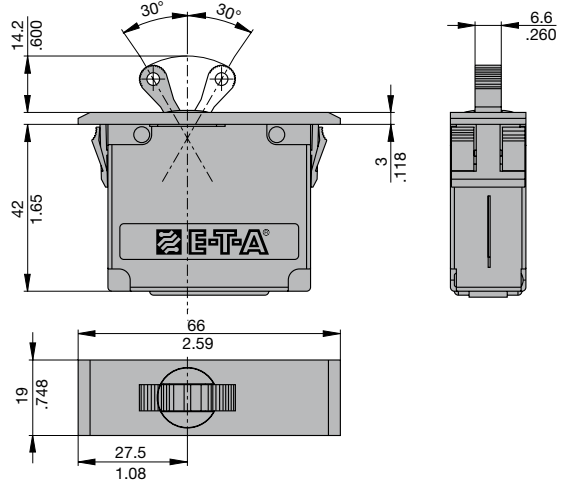

**Cut-out dimensions
recommended panel thickness: 2±0.5 mm**

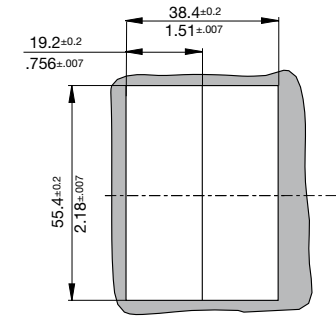

Rocker W, 3

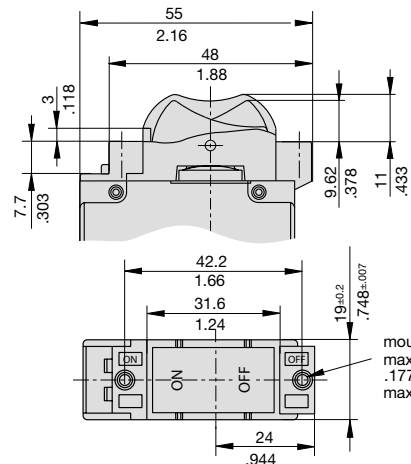

mounting thread M3 or 6-32 UNC
max. insertion depth 4.5 mm/
.177 in. to the top edge
max. tightening torque 0.5 Nm

Cut-out dimensions

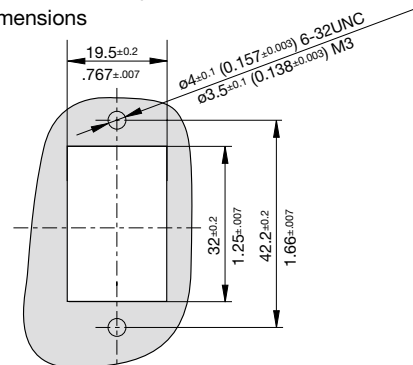

This is a metric design and millimeter dimensions take precedence (mm/inch)

Terminal design / Dimensions

P - blade terminals

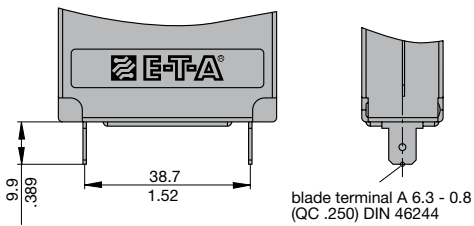

I - screw terminals, straight for busbar connection

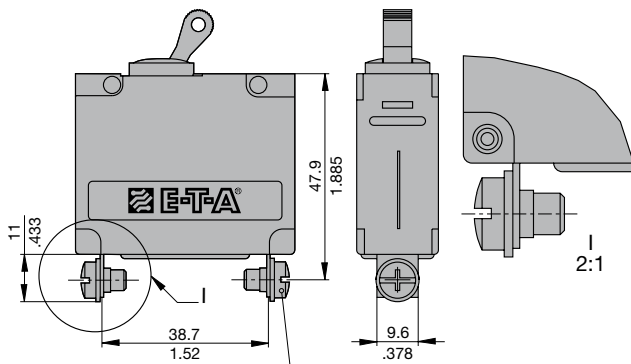

14 screw terminals with metric thread, M5 (busbar connection)
 15 screw terminals with 8-32UNC (busbar connection)
 16 screw terminals with 10-32UNC (busbar connection)
 tightening torque max. 1.2 Nm

K - screw terminals

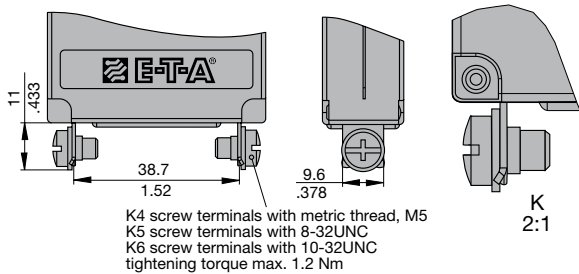

K4 screw terminals with metric thread, M5
 K5 screw terminals with 8-32UNC
 K6 screw terminals with 10-32UNC
 tightening torque max. 1.2 Nm

Q - screw terminal

Line = I, Load = K

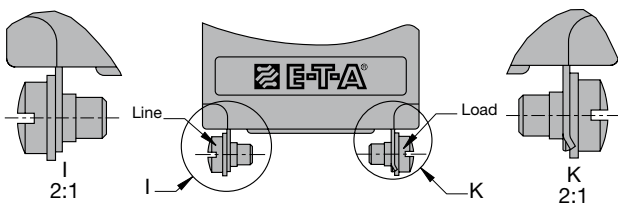

Auxiliary contact version (K)
 in pole one only

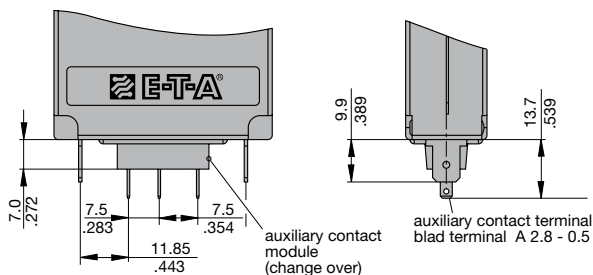

Installation drawing

Only front mounting on a vertical even surface ensures trip value as indicated

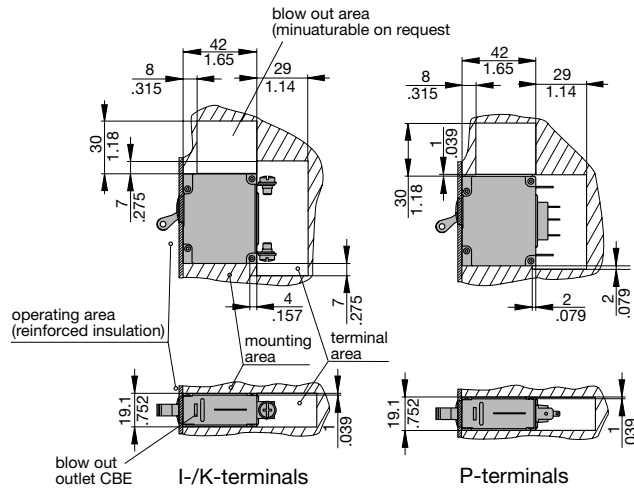

Internal connection diagrams

1-pole protected hydraulic-magnetically

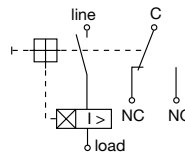

multipole

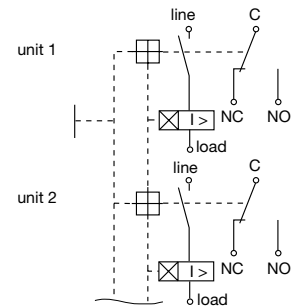

Shock directions / Mounting attitudes

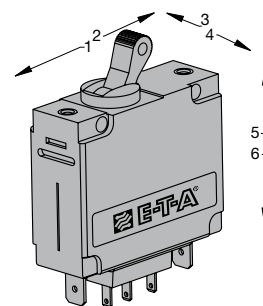

This is a metric design and millimeter dimensions take precedence (mm / inch)

Typical time/current characteristics at 23 °C/+73.4 °F

Curve K1

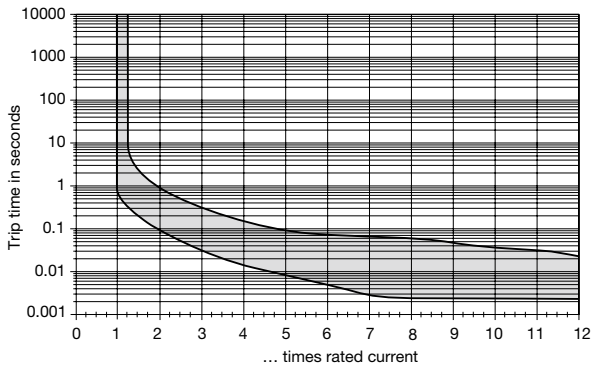

Curve K2

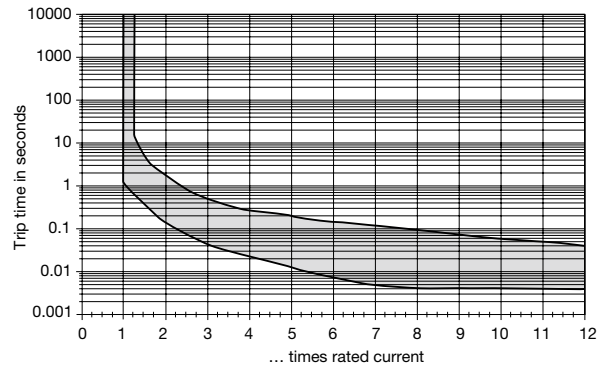

Curve M1

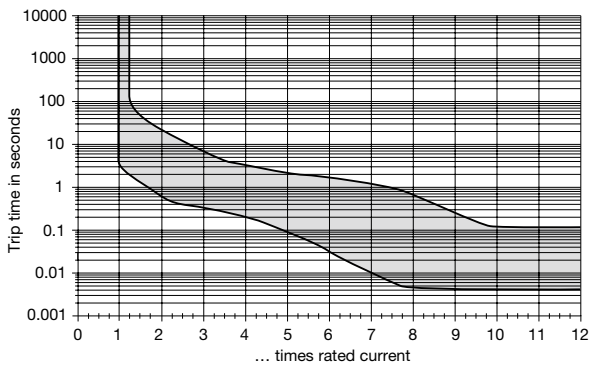

Curve M2

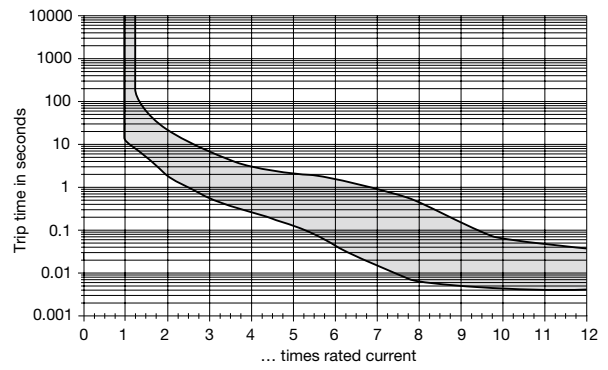

Curve T1

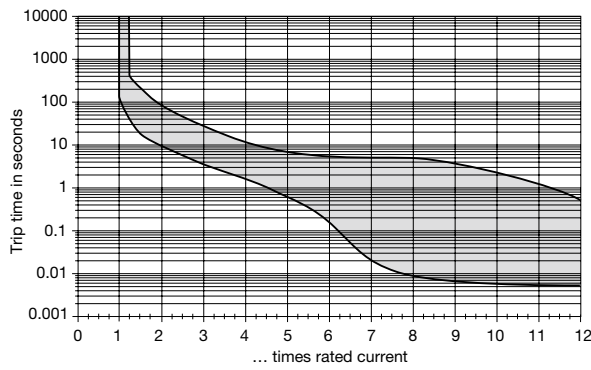

Curve T2

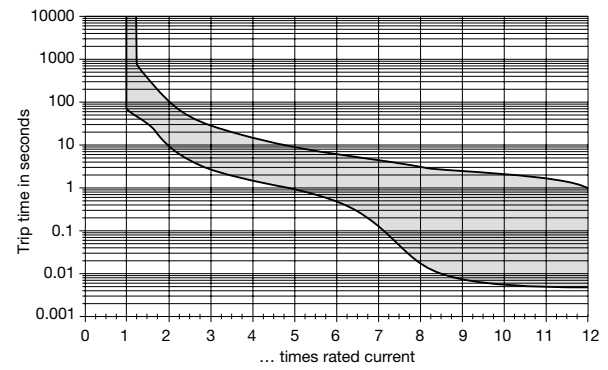

All dimensions without tolerances are for reference only. In the interest of improved design, performance and cost effectiveness the right to make changes in these specifications without notice is reserved. Product markings may not be exactly as the ordering codes. Errors and omissions excepted.

Actuator configuration

Actuator A / B

Flange mounting -F1 / -F4

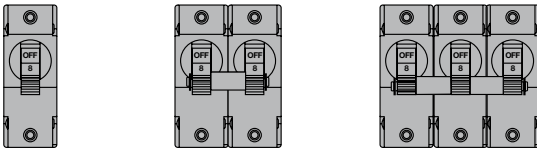

Actuator A / B

Flange mounting -F9

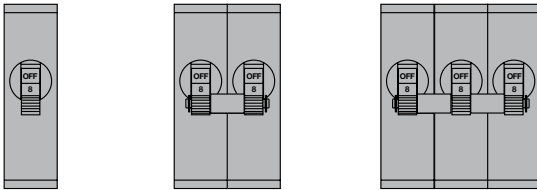

Actuator K / L

Flange mounting -F1 / -F4

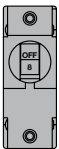

Actuator K / L

Flange mounting -F9



Actuator 1/2

Flange mounting F1/F4

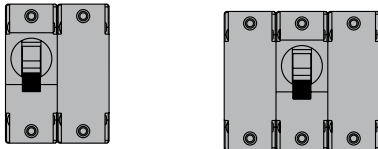

Actuator Z

Flange mounting F1/F4

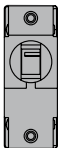

Type of actuator

Rocker

-W



-3

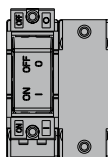

-3

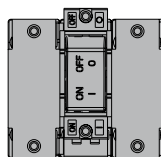

Accessories

Splash cover (IP54) for 1, 2, 3 pole

(only for mounting version F1/F2, with toggle)

For 2 and 3 poles splash cover mounted with a holding plate

1-pole Y 303 565 01

Cut-out dimensions

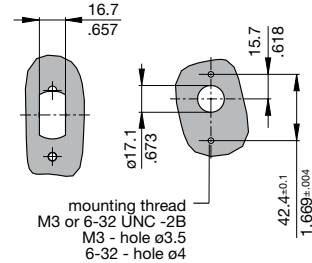
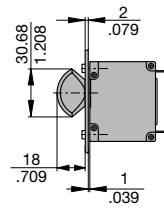

mounting thread
M3 or 6-32 UNC -2B
M3 - hole $\phi 3.5$
6-32 - hole $\phi 4$

2-pole X 211 118 02

Cut-out dimensions

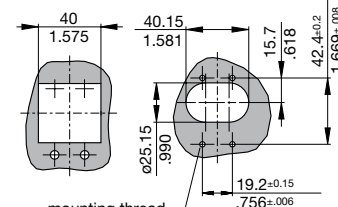
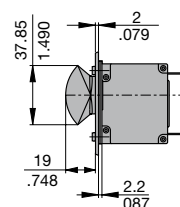

mounting thread
M3 or 6-32 UNC -2B
M3 - hole $\phi 3.5$
6-32 - hole $\phi 4$

3-pole X 211 119 02

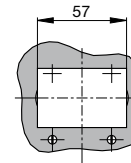
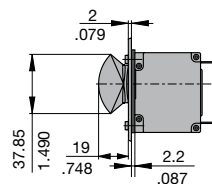

Cut-out dimensions

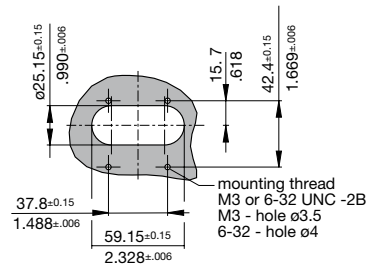

mounting thread
M3 or 6-32 UNC -2B
M3 - hole $\phi 3.5$
6-32 - hole $\phi 4$

Toggle guard Y 307 250 01

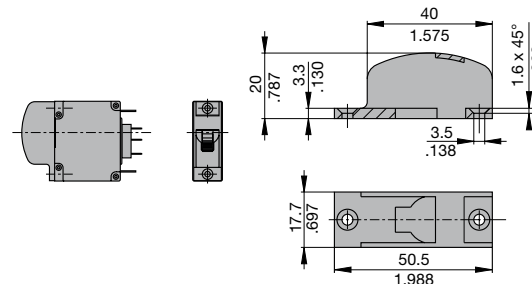

This is a metric design and millimeter dimensions take precedence ($\frac{mm}{inch}$)