

**LOW-POWER OFF-LINE PRIMARY SIDE REGULATION CONTROLLER AP3703****General Description**

The AP3703 is a high performance AC/DC power supply controller for battery charger and adapter applications. The device uses Pulse Frequency Modulation (PFM) method to build discontinuous conduction mode (DCM) flyback power supplies.

The AP3703 provides accurate constant voltage, constant current (CV/CC) regulation while removing the opto-coupler and secondary control circuitry. It also eliminates the need of loop compensation circuitry while maintaining stability. The AP3703 achieves excellent regulation and high average efficiency, yet meets the requirement for no-load consumption less than 100mW.

The AP3703 is available in SOT-23-5 package.

Features

- Primary Side Control for Rectangular Constant Current and Constant Voltage Output
- Secondary CV/CC Control Circuitry Eliminating Opto-Coupler
- No Need for Control Loop Compensation Circuitry
- Flyback Topology in DCM Operation
- Random Frequency Modulation to Reduce System EMI
- Maximum Switching Frequency: 60kHz
- Built-in Soft Start
- Open Feedback Protection
- Over Voltage Protection
- Short Circuit Protection
- Small SOT-23-5 package to achieve compact size and less component

Applications

- Adapters/Chargers for Cell/Cordless Phones, PDAs, MP3 and Other Portable Apparatus
- Standby and Auxiliary Power Supplies
- LED Driver

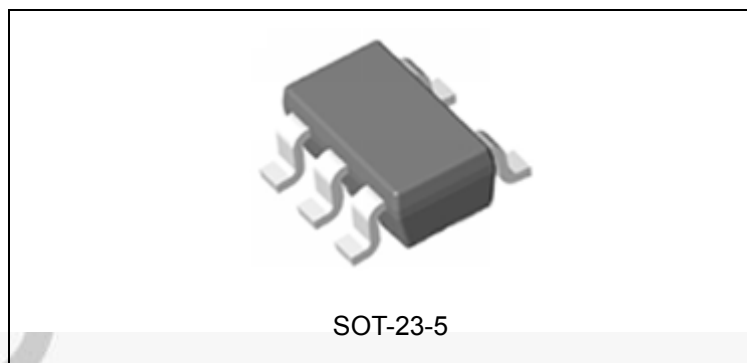

Figure 1. Package Type of AP3703



PART OBSOLETE

Preliminary Datasheet

LOW-POWER OFF-LINE PRIMARY SIDE REGULATION CONTROLLER AP3703

Pin Configuration

K Package
(SOT-23-5)

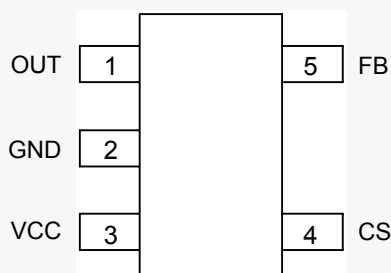

Figure 2. Pin Configuration of AP3703 (Top View)

Pin Description

Pin Number	Pin Name	Function
1	OUT	This pin drives the base of external power NPN switch
2	GND	Ground
3	VCC	Supply voltage
4	CS	The primary current sense
5	FB	The voltage feedback from the auxiliary winding



PART OBSOLETE

Preliminary Datasheet

LOW-POWER OFF-LINE PRIMARY SIDE REGULATION CONTROLLER AP3703

Functional Block Diagram

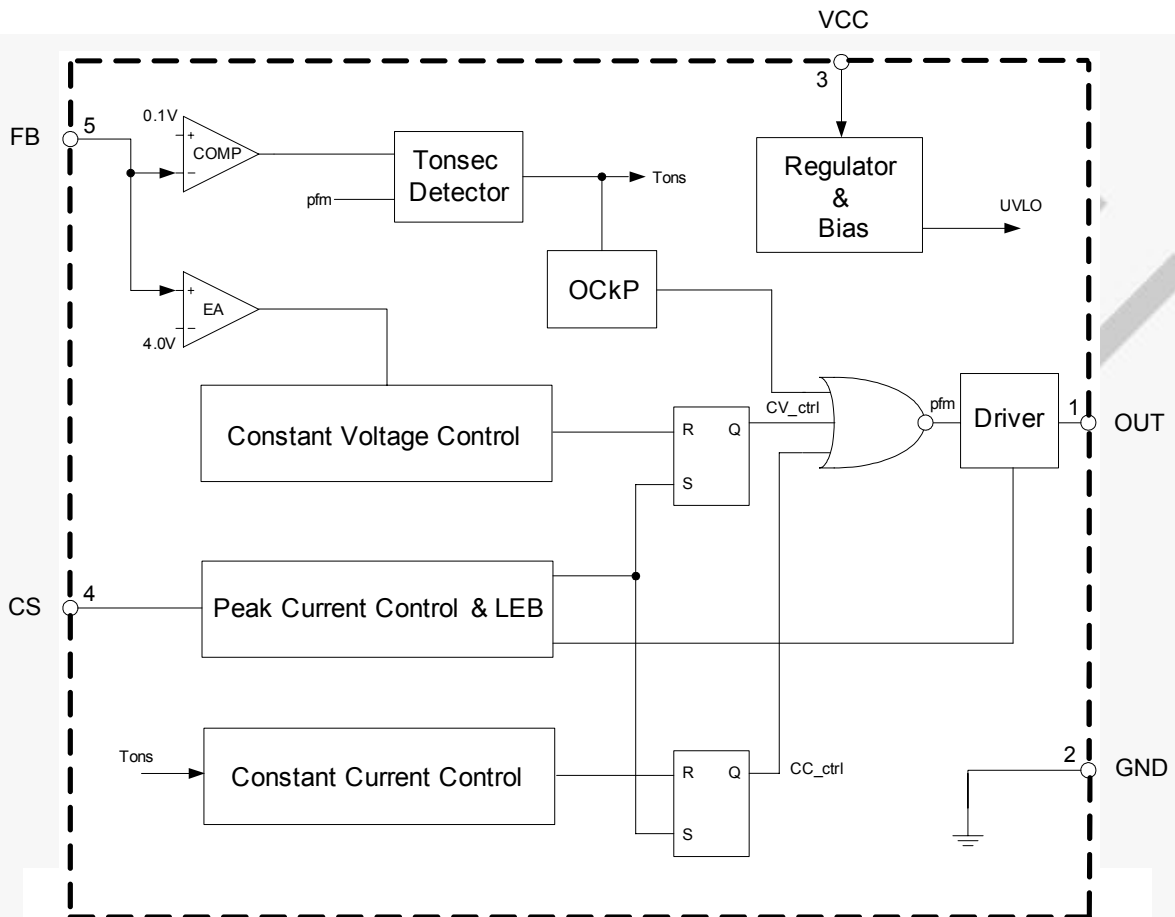

Figure 3. Functional Block Diagram of AP3703



PART OBSOLETE

Preliminary Datasheet

LOW-POWER OFF-LINE PRIMARY SIDE REGULATION CONTROLLER AP3703

Ordering Information

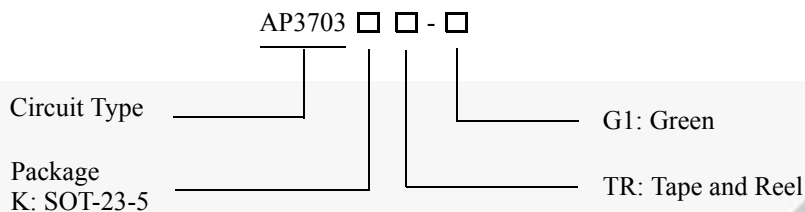

Package	Temperature Range	Part Number	Marking ID	Packing Type
SOT-23-5	-40 to 85°C	AP3703KTR-G1	GAT	Tape & Reel

BCD Semiconductor's products, as designated with "G1" suffix in the part number, are RoHS compliant and Green.

Absolute Maximum Ratings (Note 1)

Parameter	Value	Unit
Supply Voltage VCC	-0.3 to 30	V
Voltage at CS, OUT to GND	-0.3 to 7	V
FB input (Pin 5)	-40 to 10	V
Output Current at OUT	Internally limited	A
Operating Junction Temperature	150	°C
Storage Temperature	-65 to 150	°C
Lead Temperature (Soldering, 10s)	300	°C
Thermal Resistance Junction-to-Ambient	250	°C/W
ESD (Machine Model)	200	V
ESD (Human Body Model)	2000	V

Note 1: Stresses greater than those listed under "Absolute Maximum Ratings" may cause permanent damage to the device. These are stress ratings only, and functional operation of the device at these or any other conditions beyond those indicated under "Recommended Operating Conditions" is not implied. Exposure to "Absolute Maximum Ratings" for extended periods may affect device reliability.

OBSOLETE - PART DISCONTINUED



PART OBSOLETE

Preliminary Datasheet

LOW-POWER OFF-LINE PRIMARY SIDE REGULATION CONTROLLER AP3703**Electrical Characteristics**(V_{CC}=15V, T_A=25°C, unless otherwise specified.)

Parameter	Symbol	Conditions	Min	Typ	Max	Unit
UVLO SECTION						
Start-up Threshold	V _{TH(ST)}		16.5	19.5	22.5	V
Minimal Operating Voltage	V _{OPR(min)}		5.8	7.5	9.5	V
STANDBY CURRENT SECTION						
Start-up Current	I _{ST}	V _{CC} =V _{TH(ST)} -0.5V, Before start-up		45	60	μA
Operating Current	I _{CC(OPR)}	Static		250	350	μA
DRIVE OUTPUT SECTION						
OUT Maximum Current	Sink	I _{OUT}	50			mA
	Source		24	32	40	
Maximum Switching Frequency			60			kHz
CURRENT SENSE SECTION						
Current Sense Threshold	V _{CS}		410	465	530	mV
Pre-Current Sense	V _{CS(PRE)}		345	395	440	mV
Leading Edge Blanking				750		ns
FEEDBACK INPUT SECTION						
Feedback Pin Input Leakage Current	I _{FB}	V _{FB} =4V	2	2.8	3.6	μA
Feedback Threshold	V _{FB}		3.70	3.95	4.20	V
Over Voltage Protection	V _{FB(OVP)}		6.4	8	9.6	V



PART OBSOLETE

Preliminary Datasheet

LOW-POWER OFF-LINE PRIMARY SIDE REGULATION CONTROLLER AP3703

Typical Performance Characteristics

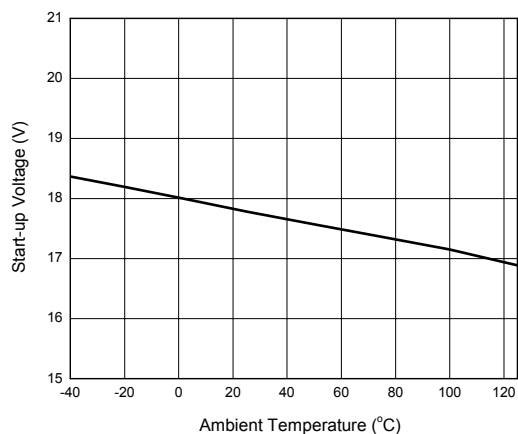

Figure 4. Start-up Voltage vs. Ambient Temperature

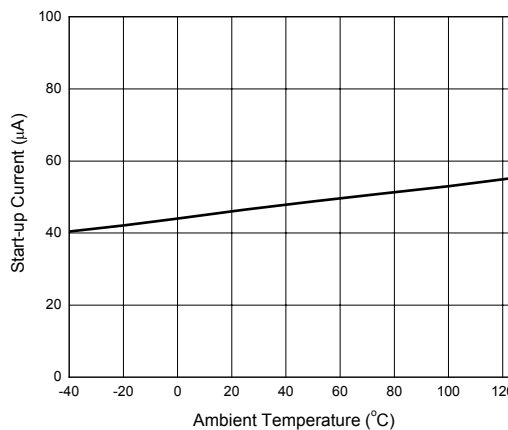

Figure 5. Start-up Current vs. Ambient Temperature

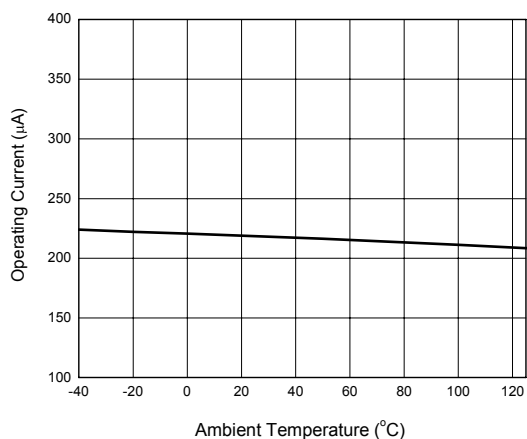

Figure 6. Operating Current vs. Ambient Temperature



PART OBSOLETE

Preliminary Datasheet

LOW-POWER OFF-LINE PRIMARY SIDE REGULATION CONTROLLER AP3703

Typical Application

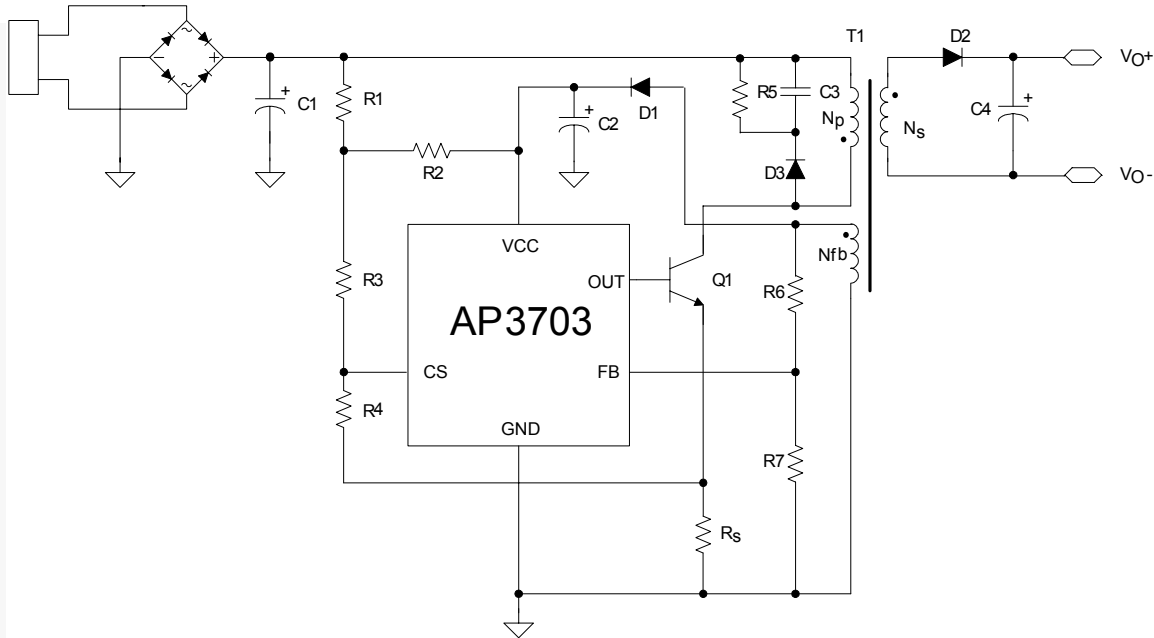

Figure 7. 5V/500mA Output for Battery Charger of Mobile Phone



PART OBSOLETE

Preliminary Datasheet

LOW-POWER OFF-LINE PRIMARY SIDE REGULATION CONTROLLER AP3703

Mechanical Dimensions

SOT-23-5

Unit: mm(inch)

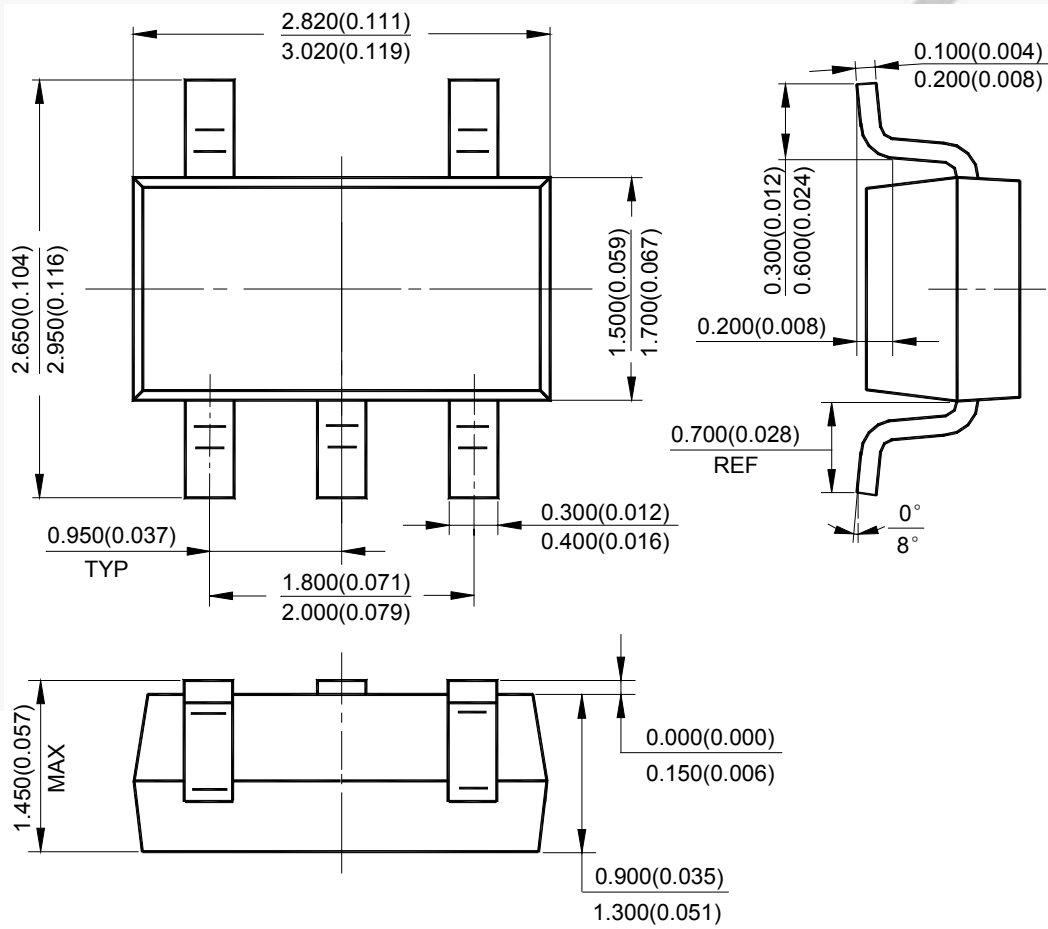

PART OBSOLETE



BCD Semiconductor Manufacturing Limited

<http://www.bcdsemi.com>

IMPORTANT NOTICE

BCD Semiconductor Manufacturing Limited reserves the right to make changes without further notice to any products or specifications herein. BCD Semiconductor Manufacturing Limited does not assume any responsibility for use of any its products for any particular purpose, nor does BCD Semiconductor Manufacturing Limited assume any liability arising out of the application or use of any its products or circuits. BCD Semiconductor Manufacturing Limited does not convey any license under its patent rights or other rights nor the rights of others.

MAIN SITE

- Headquarters

BCD Semiconductor Manufacturing Limited

No. 1600, Zi Xing Road, Shanghai Zizhu Science-based Industrial Park, 200241, China
Tel: +86-21-24162266, Fax: +86-21-24162277

- Wafer Fab

Shanghai SIM-BCD Semiconductor Manufacturing Co., Ltd.

800 Yi Shan Road, Shanghai 200233, China
Tel: +86-21-6485 1491, Fax: +86-21-5450 0008

REGIONAL SALES OFFICE

Shenzhen Office

Shanghai SIM-BCD Semiconductor Manufacturing Co., Ltd., Shenzhen Office

Unit A Room 1203, Skyworth Bldg., Gaoxin Ave. 1.S., Nanshan District, Shenzhen, China

Tel: +86-755-8826 7951
Fax: +86-755-8826 7865

Taiwan Office

BCD Semiconductor (Taiwan) Company Limited

4F, 298-1, Rui Guang Road, Nei-Hu District, Taipei, Taiwan

Tel: +886-2-2656 2808
Fax: +886-2-2656 2806

USA Office

BCD Semiconductor Corp.

30920 Huntwood Ave. Hayward, CA 94544, USA

Tel : +1-510-324-2988
Fax: +1-510-324-2788