



Improved, Dual, High-Speed Analog Switches

DG401/DG403/DG405

General Description

Maxim's redesigned DG401/DG403/DG405 analog switches now feature guaranteed low on-resistance matching between switches (2Ω max) and guaranteed on-resistance flatness over the signal range (3Ω max). These low on-resistance switches (20Ω typ) conduct equally well in either direction and are guaranteed to have low charge injection (15pC max). The new design offers lower off leakage current over temperature (less than 5nA at $+85^\circ\text{C}$).

The DG401/DG403/DG405 are dual, high-speed switches. The single-pole/single-throw DG401 and double-pole/single-throw DG405 are normally open dual switches. The dual, single-pole/double-throw DG403 has two normally open and two normally closed switches. Switching times are 150ns max for t_{ON} and 100ns max for t_{OFF} , with a maximum power consumption of $35\mu\text{W}$. These devices operate from a single $+10\text{V}$ to $+30\text{V}$ supply, or bipolar supplies of $\pm 4.5\text{V}$ to $\pm 20\text{V}$. Maxim's improved DG401/DG403/DG405 are fabricated with a 44V silicon-gate process.

Applications

- | | |
|------------------------------|----------------------|
| Sample-and-Hold Circuits | Test Equipment |
| Guidance and Control Systems | Heads-Up Displays |
| Communications Systems | PBX, PABX |
| Battery-Operated Systems | Audio Signal Routing |
| Military Radios | |

New Features

- ◆ Plug-In Upgrade for Industry-Standard DG401/DG403/DG405
- ◆ Improved $r_{\text{DS(ON)}}$ Match Between Channels (2Ω max)
- ◆ Guaranteed $r_{\text{FLAT(ON)}}$ Over Signal Range (3Ω max)
- ◆ Improved Charge Injection (15pC max)
- ◆ Improved Off Leakage Current Over Temperature ($<5\text{nA}$ at $+85^\circ\text{C}$)

Existing Features

- ◆ Low $r_{\text{DS(ON)}}$ (30Ω max)
- ◆ Single-Supply Operation $+10\text{V}$ to $+30\text{V}$
Bipolar-Supply Operation $\pm 4.5\text{V}$ to $\pm 20\text{V}$
- ◆ Low Power Consumption ($35\mu\text{W}$ max)
- ◆ Rail-to-Rail Signal Handling Capability
- ◆ TTL/CMOS-Logic Compatible

Ordering Information

PART	TEMP. RANGE	PIN PACKAGE
DG401CJ	0°C to $+70^\circ\text{C}$	16 Plastic DIP
DG401CY	0°C to $+70^\circ\text{C}$	16 Narrow SO
DG401C/D	0°C to $+70^\circ\text{C}$	Dice*

Ordering information continued on last page.
*Contact factory for dice specifications.

Pin Configurations/Functional Diagrams/Truth Tables

TOP VIEW

DIP/SO

DG401	
LOGIC	SWITCH
0	OFF
1	ON

LCC packages on last page.

DIP/SO

DG403		
LOGIC	SWITCHES 1, 2	SWITCHES 3, 4
0	OFF	ON
1	ON	OFF

SWITCHES SHOWN FOR LOGIC "0" INPUT

DIP/SO

DG405	
LOGIC	SWITCH
0	OFF
1	ON

N.C. = NOT INTERNALLY CONNECTED



For free samples & the latest literature: <http://www.maxim-ic.com>, or phone 1-800-998-8800.
For small orders, phone 1-800-835-8769.

Improved, Dual, High-Speed Analog Switches

ABSOLUTE MAXIMUM RATINGS

Voltage Referenced to V-

V+	44V
GND	25V
V _L	(GND - 0.3V) to (V+ + 0.3V)
Digital Inputs, V _S , V _D (Note 1)	(V- - 2V) to (V+ + 2V) or 20mA (whichever occurs first)

Continuous Current (any terminal)	30mA
Continuous Current, S or D	20mA
Peak Current, S or D (pulsed at 1ms, 10% duty cycle max)	100mA

Continuous Power Dissipation (T_A = +70°C)

16-Pin Plastic DIP (derate 10.53mW/°C above +70°C) ...	842mW
16-Pin Narrow SO (derate 8.70mW/°C above +70°C) ...	696mW
16-Pin CERDIP (derate 10.00mW/°C above 70°C)	800mW
20-Pin LCC (derate 9.09mW/°C above +70°C)	727mW

Operating Temperature Ranges

DG40_C_	0°C to +70°C
DG40_D_	-40°C to +85°C
DG40_A_	-55°C to +125°C
Storage Temperature Range	-65°C to +150°C
Lead Temperature (soldering, 10sec)	+300°C

Note 1: Signals on S, D or IN exceeding V+ or V- are clamped by internal diodes. Limit forward current to maximum current rating.

Stresses beyond those listed under "Absolute Maximum Ratings" may cause permanent damage to the device. These are stress ratings only, and functional operation of the device at these or any other conditions beyond those indicated in the operational sections of the specifications is not implied. Exposure to absolute maximum rating conditions for extended periods may affect device reliability.

ELECTRICAL CHARACTERISTICS

(V+ = 15V, V- = -15V, V_L = +5V, GND = 0V, V_{INH} = +2.4V, V_{INL} = +0.8V, T_A = T_{MIN} to T_{MAX}, unless otherwise noted.)

PARAMETER	SYMBOL	CONDITIONS	TEMP. RANGE	MIN	TYP (Note 2)	MAX	UNITS	
SWITCH								
Analog Signal Range	V _{ANALOG}	(Note 3)		-15		+15	V	
Drain-Source On-Resistance	r _{DS(ON)}	V+ = 13.5V, V- = -13.5V, I _S = -10mA, V _D = ±10V, V _{INH} = 2.4V, V _{INL} = 0.8V	T _A = +25°C	C, D	20	45	Ω	
				A	20	30		
		T _A = T _{MIN} to T _{MAX}	C, D		55			
			A		45			
Drain-Source On-Resistance Match Between Channels (Note 4)	Δr _{DS(ON)}	V+ = 15V, V- = -15V, I _S = -10mA, V _D = ±10V	T _A = +25°C	C, D, A	0.5	2	Ω	
			T _A = T _{MIN} to T _{MAX}					
On-Resistance Flatness (Note 4)	r _{FLAT(ON)}	V+ = 15V, V- = -15V, I _S = -10mA, V _D = ±5V, 0V	T _A = +25°C	C, D, A		3	Ω	
			T _A = T _{MIN} to T _{MAX}					
Source-Off Leakage Current (Note 7)	I _{S(OFF)}	V+ = 16.5V, V- = -16.5V, V _D = ±15.5V, V _S = ±15.5V	T _A = +25°C	C, D	-0.50	-0.01	0.50	nA
				A	-0.25	-0.01	0.25	
			T _A = T _{MIN} to T _{MAX}	C, D	-5		5	
				A	-10		10	
Drain-Off Leakage Current (Note 7)	I _{D(OFF)}	V+ = 16.5V, V- = -16.5V, V _D = ±15.5V, V _S = ±15.5V	T _A = +25°C	C, D	-0.50	-0.01	0.50	nA
				A	-0.25	-0.01	0.25	
			T _A = T _{MIN} to T _{MAX}	C, D	-5		5	
				A	-10		10	
Drain-On Leakage Current (Note 7)	I _{D(ON)} or I _{S(ON)}	V+ = 16.5V, V- = -16.5V, V _D = ±15.5V, V _S = ±15.5V	T _A = +25°C	C, D	-1.0	-0.04	1.0	nA
				A	-0.4	-0.04	0.4	
	T _A = T _{MIN} to T _{MAX}		C, D	-10		10		
			A	-20		20		

Improved, Dual, High-Speed Analog Switches

DG401/DG403/DG405

ELECTRICAL CHARACTERISTICS (continued)

(V+ = 15V, V- = -15V, VL = +5V, GND = 0V, VINH = +2.4V, VINL = +0.8V, TA = TMIN to TMAX, unless otherwise noted.)

PARAMETER	SYMBOL	CONDITIONS	MIN	TYP (Note 2)	MAX	UNITS	
INPUT							
Input Current with Input Voltage High	IINH	VIN = 2.4V, all others = 0.8V	-1.0	0.005	1.0	μA	
Input Current with Input Voltage Low	IINL	VIN = 0.8V, all others = 2.4V	-1.0	0.005	1.0	μA	
SUPPLY							
Power-Supply Range			±4.5		±20	V	
Positive Supply Current	I+	All channels on or off, V+ = 16.5V, V- = -16.5V, VIN = 0V or 5V	TA = +25°C	-1.0	0.01	1.0	μA
			TA = TMIN to TMAX	-5.0		5.0	
Negative Supply Current	I-	All channels on or off, V+ = 16.5V, V- = -16.5V, VIN = 0V or 5V	TA = +25°C	-1.0	0.01	1.0	μA
			TA = TMIN to TMAX	-5.0		5.0	
Logic Supply Current	IL	All channels on or off, V+ = 16.5V, V- = -16.5V, VIN = 0V or 5V	TA = +25°C	-1.0	0.01	1.0	μA
			TA = TMIN to TMAX	-5.0		5.0	
Ground Current	IGND	All channels on or off, V+ = 16.5V, V- = -16.5V, VIN = 0V or 5V	TA = +25°C	-1.0	0.01	1.0	μA
			TA = TMIN to TMAX	-5.0		5.0	
DYNAMIC							
Turn-On Time	tON	Figure 2	TA = +25°C	100	150	ns	
Turn-Off Time	tOFF	Figure 2	TA = +25°C	60	100	ns	
Break-Before-Make Delay (Note 3)	tD	DG403 only, Figure 3	TA = +25°C	10	20	ns	
Charge Injection (Note 3)	Q	CL = 1.0nF, VGEN = 0V, RGEN = 0Ω, Figure 4	TA = +25°C	10	15	pC	
Off Isolation (Note 5)	OIRR	RL = 100Ω, CL = 5pF, f = 1MHz, Figure 5	TA = +25°C	72		dB	
Crosstalk (Note 6)		RL = 50Ω, CL = 5pF, f = 1MHz, Figure 6	TA = +25°C	90		dB	
Source-Off Capacitance	CS(OFF)	f = 1MHz, Figure 7	TA = +25°C	12		pF	
Drain-Off Capacitance	CD(OFF)	f = 1MHz, Figure 7	TA = +25°C	12		pF	
Channel-On Capacitance	CD(ON) or CS(ON)	f = 1MHz, Figure 8	TA = +25°C	39		pF	

Note 2: This data sheet uses the algebraic convention, where the most negative value is a minimum and the most positive value is a maximum.

Note 3: Guaranteed by design.

Note 4: $\Delta r_{ON} = \Delta r_{ON(max)} - \Delta r_{ON(min)}$. On-resistance match between channels and flatness are guaranteed only with specified voltages. Flatness is defined as the difference between the maximum and minimum value of on-resistance as measured at the extremes of the specified analog signal range.

Note 5: Off isolation = $20 \log (V_S/V_D)$, V_D = output, V_S = input to off switch.

Note 6: Between any two switches.

Note 7: Leakage parameters IS(OFF), ID(OFF), and ID(ON) are 100% tested at the maximum rated hot temperature and guaranteed by correlation at +25°C.

Improved, Dual, High-Speed Analog Switches

Typical Operating Characteristics

($T_A = +25^\circ\text{C}$, unless otherwise noted.)

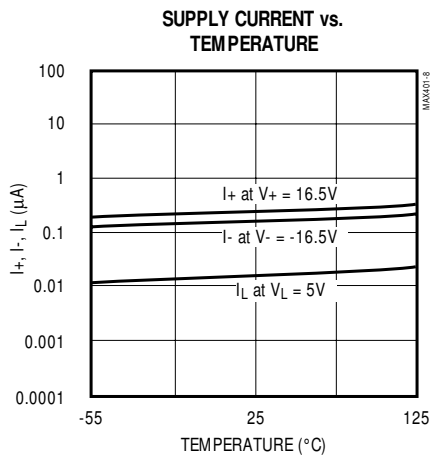
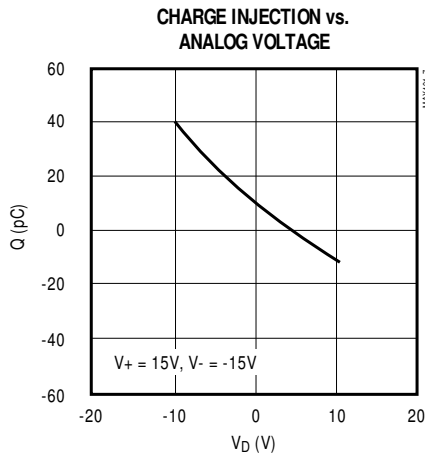
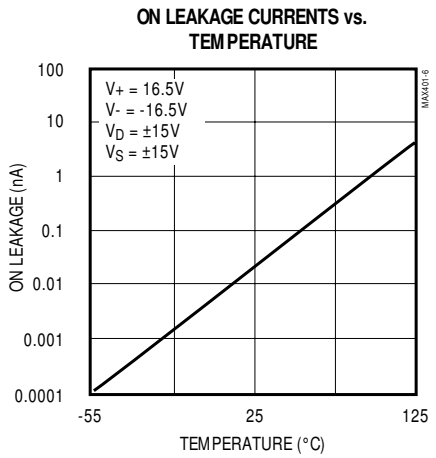
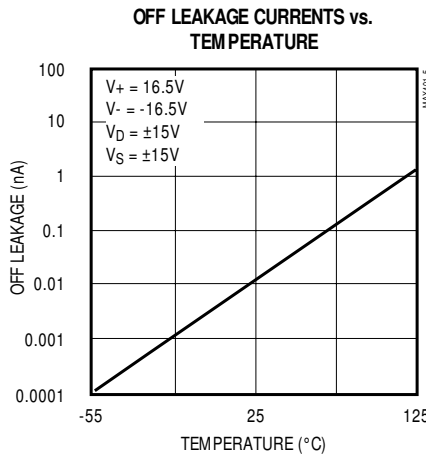
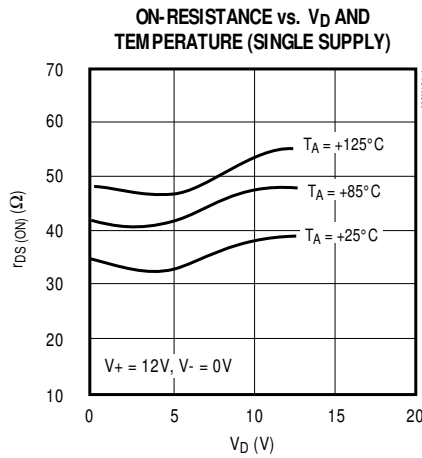
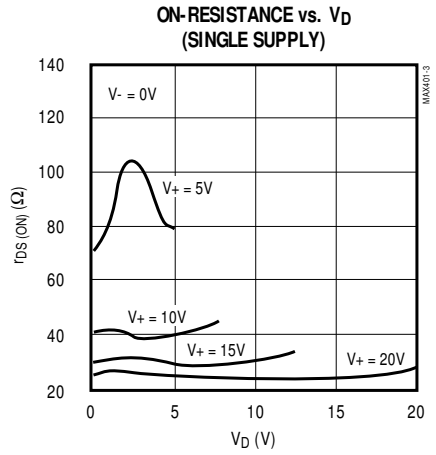
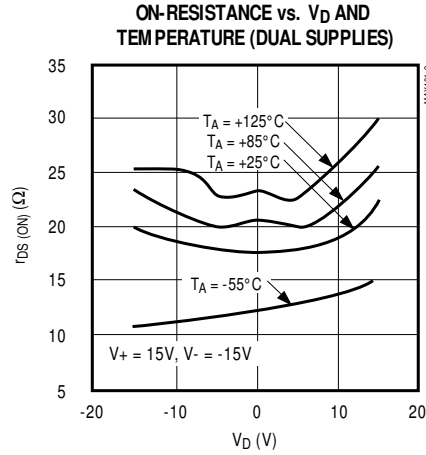
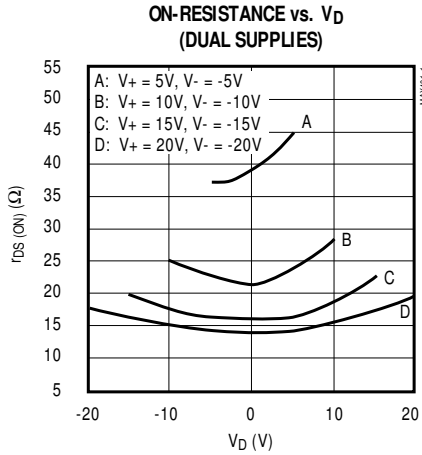

Improved, Dual, High-Speed Analog Switches

DG401/DG403/DG405

Pin Description

DG401		NAME	FUNCTION
DIP/SO	LCC		
1, 8	2, 10	D1, D2	Drain (Analog Signal)
2-7	1, 3-9, 11, 16	N.C.	Not internally connected
9, 16	12, 20	S2, S1	Source (Analog Signal)
10, 15	13, 19	IN2, IN1	Digital Logic Inputs
11	14	V+	Positive Supply-Voltage Input—connected to substrate
12	15	V _L	Logic Supply-Voltage Input
13	17	GND	Ground
14	18	V-	Negative Supply-Voltage Input
DG403		NAME	FUNCTION
DIP/SO	LCC		
1, 8, 3, 6	2, 10, 4, 8	D1-D4	Drain (Analog Signal)
2, 7	1, 3, 6, 9, 11, 16	N.C.	Not internally connected
16, 9, 4, 5	20, 12, 5, 7,	S1-S4	Source (Analog Signal)
10, 15	13, 19	IN2, IN1	Digital Logic Inputs
11	14	V+	Positive Supply-Voltage Input—connected to substrate
12	15	V _L	Logic Supply-Voltage Input
13	17	GND	Ground
14	18	V-	Negative Supply-Voltage Input
DG405		NAME	FUNCTION
DIP/SO	LCC		
1, 8, 3, 6	2, 10, 4, 8	D1-D4	Drain (Analog Signal)
2, 7	1, 3, 6, 9, 11, 16	N.C.	Not internally connected
16, 9, 4, 5	20, 12, 5, 7,	S1-S4	Source (Analog Signal)
10, 15	13, 19	IN2, IN1	Digital Logic Inputs
11	14	V+	Positive Supply-Voltage Input—connected to substrate
12	15	V _L	Logic Supply-Voltage Input
13	17	GND	Ground
14	18	V-	Negative Supply Voltage

Applications Information

Operation with Supply Voltages Other than $\pm 15V$

The DG401/DG403/DG405 switches operate with $\pm 4.5V$ to $\pm 20V$ bipolar supplies or with a $+10V$ to $+30V$ single supply. In either case, analog signals ranging from V_+ to V_- can be switched. The *Typical Operating Characteristics* graphs illustrate typical analog-signal and supply-voltage on-resistance variations. The usual on-resistance temperature coefficient is $0.5\%/^{\circ}C$ (typ).

Logic Inputs

These devices operate with a single positive supply or with bipolar supplies. They maintain TTL compatibility with supplies anywhere in the $\pm 4.5V$ to $\pm 20V$ range as long as $V_L = +5V$. If V_L is connected to V_+ or another supply at voltages other than $+5V$, the devices will operate at CMOS-logic-level inputs.

Overvoltage Protection

Proper power-supply sequencing is recommended for all CMOS devices. Do not exceed the absolute maximum ratings because stresses beyond the listed ratings may cause permanent damage to the devices. Always sequence V_+ on first, followed by V_L , V_- , and logic inputs. If power-supply sequencing is not possible, add two small, external signal diodes in series with supply pins for overvoltage protection (Figure 1). Adding diodes reduces the analog-signal range to $1V$ below V_+ and $1V$ below V_- , without affecting low switch resistance and low leakage characteristics. Device operation is unchanged, and the difference between V_+ and V_- should not exceed $+44V$.

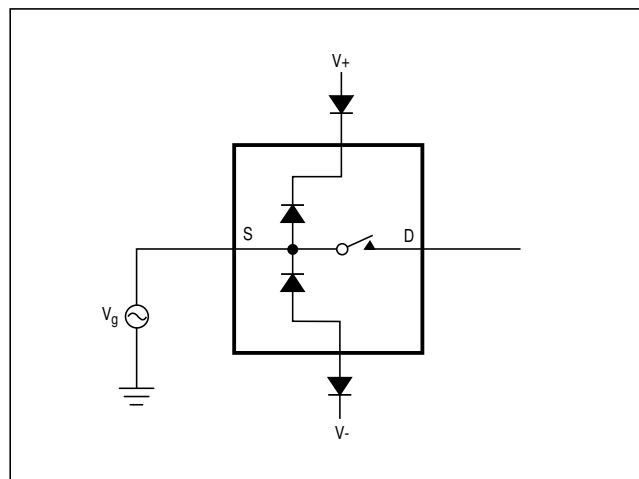

Figure 1. Overvoltage Protection Using External Blocking Diodes

Improved, Dual, High-Speed Analog Switches

Timing Diagrams/Test Circuits

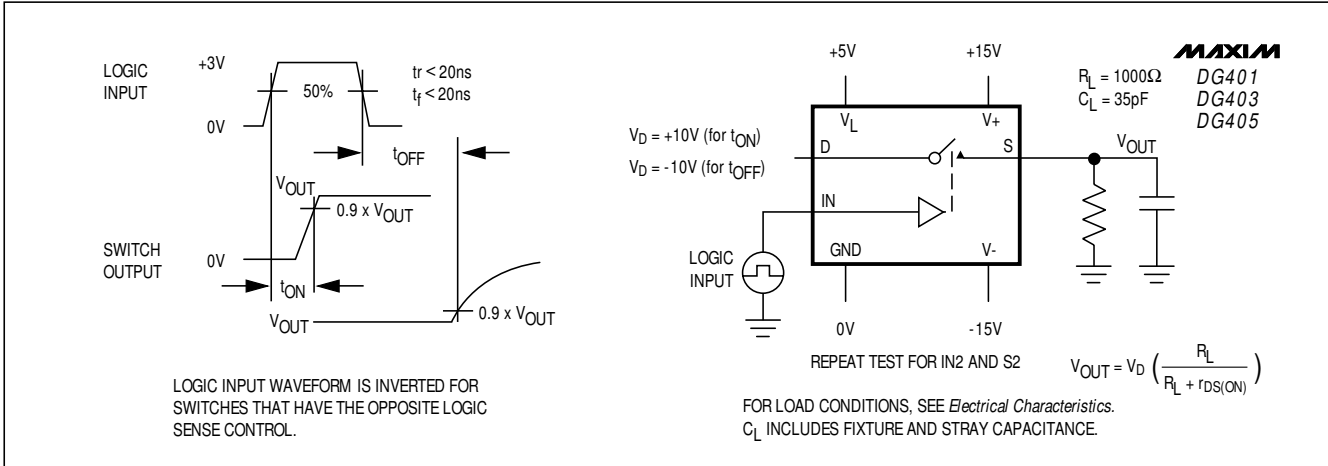

Figure 2. Switching Time

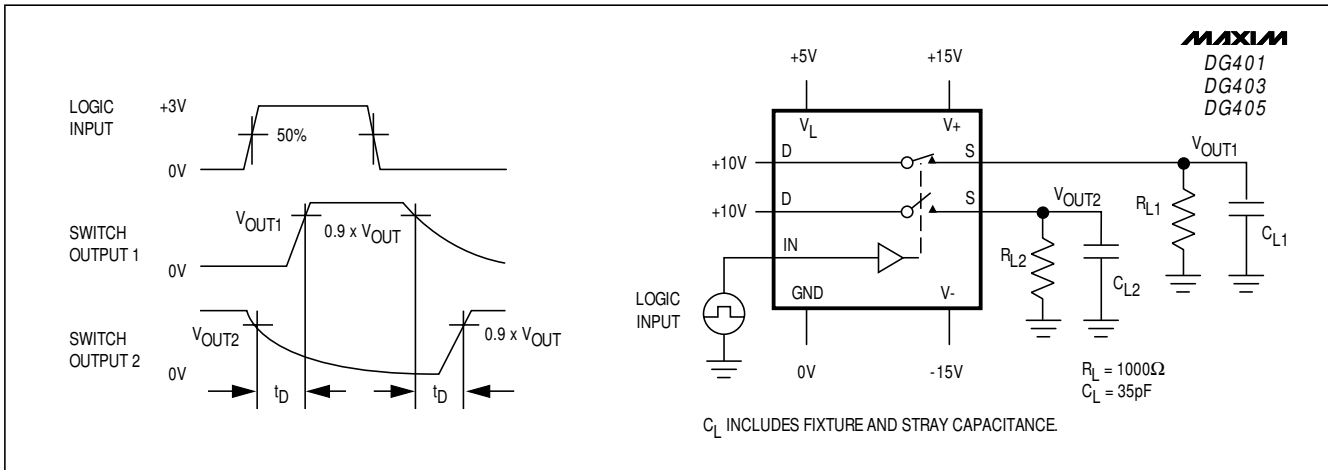

Figure 3. Break-Before-Make Interval

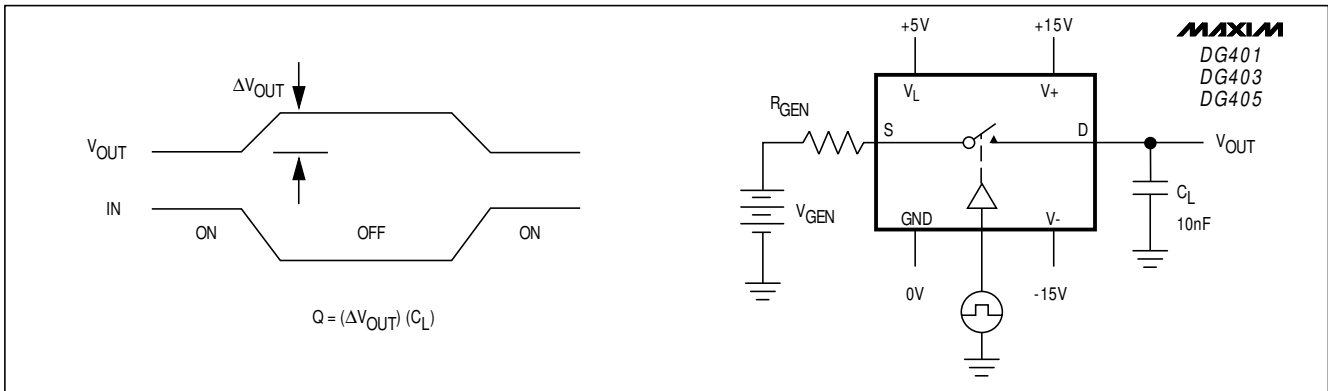

Figure 4. Charge Injection

Improved, Dual, High-Speed Analog Switches

Timing Diagrams/Test Circuits (continued)

DG401/DG403/DG405

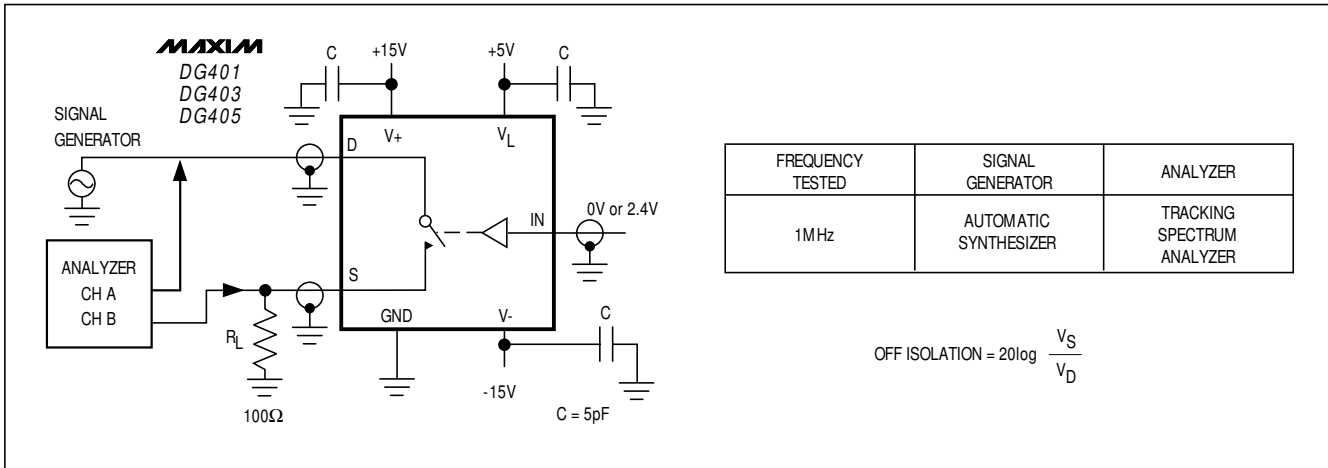

Figure 5. Off Isolation

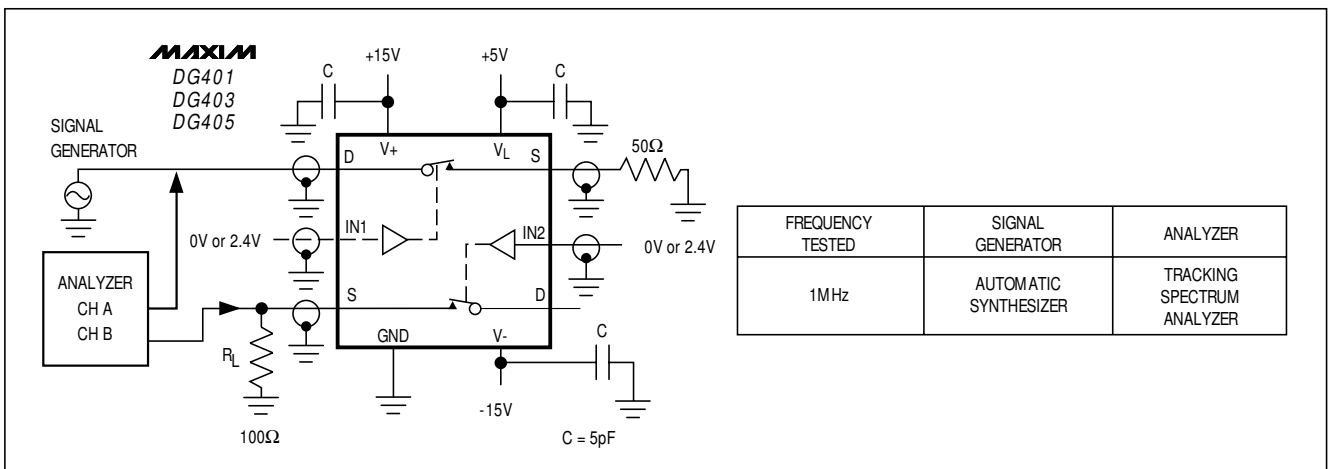

Figure 6. Crosstalk

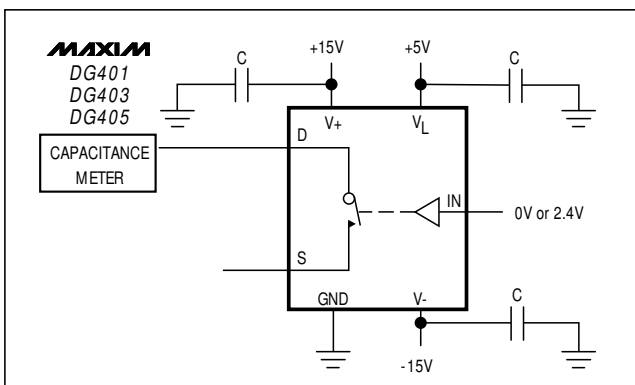

Figure 7. Channel-Off Capacitance

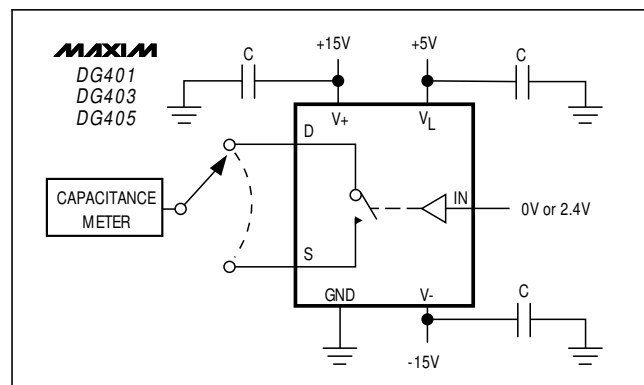

Figure 8. Channel-On Capacitance

Improved, Dual, High-Speed Analog Switches

Ordering Information (continued)

PART	TEMP. RANGE	PIN PACKAGE
DG401DJ	-40°C to +85°C	16 Plastic DIP
DG401DY	-40°C to +85°C	16 Narrow SO
DG401DK	-40°C to +85°C	16 CERDIP
DG401AK	-55°C to +125°C	16 CERDIP**
DG401AZ	-55°C to +125°C	20 LCC**
DG403CJ	0°C to +70°C	16 Plastic DIP
DG403CY	0°C to +70°C	16 Narrow SO
DG403C/D	0°C to +70°C	Dice*
DG403DJ	-40°C to +85°C	16 Plastic DIP
DG403DY	-40°C to +85°C	16 Narrow SO
DG403DK	-40°C to +85°C	16 CERDIP
DG403AK	-55°C to +125°C	16 CERDIP**
DG403AZ	-55°C to +125°C	20 LCC**
DG405CJ	0°C to +70°C	16 Plastic DIP
DG405CY	0°C to +70°C	16 Narrow SO
DG405C/D	0°C to +70°C	Dice*
DG405DJ	-40°C to +85°C	16 Plastic DIP
DG405DY	-40°C to +85°C	16 Narrow SO
DG405DK	-40°C to +85°C	16 CERDIP
DG405AK	-55°C to +125°C	16 CERDIP**
DG405AZ	-55°C to +125°C	20 LCC**

* Contact factory for dice specifications.

**Contact factory for availability and processing to MIL-STD-883B.

Chip Topography

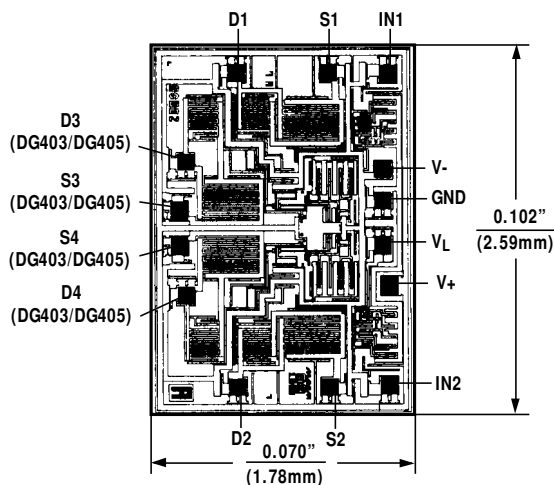

TRANSISTOR COUNT: 66
SUBSTRATE CONNECTED TO V+

Pin Configurations (continued)

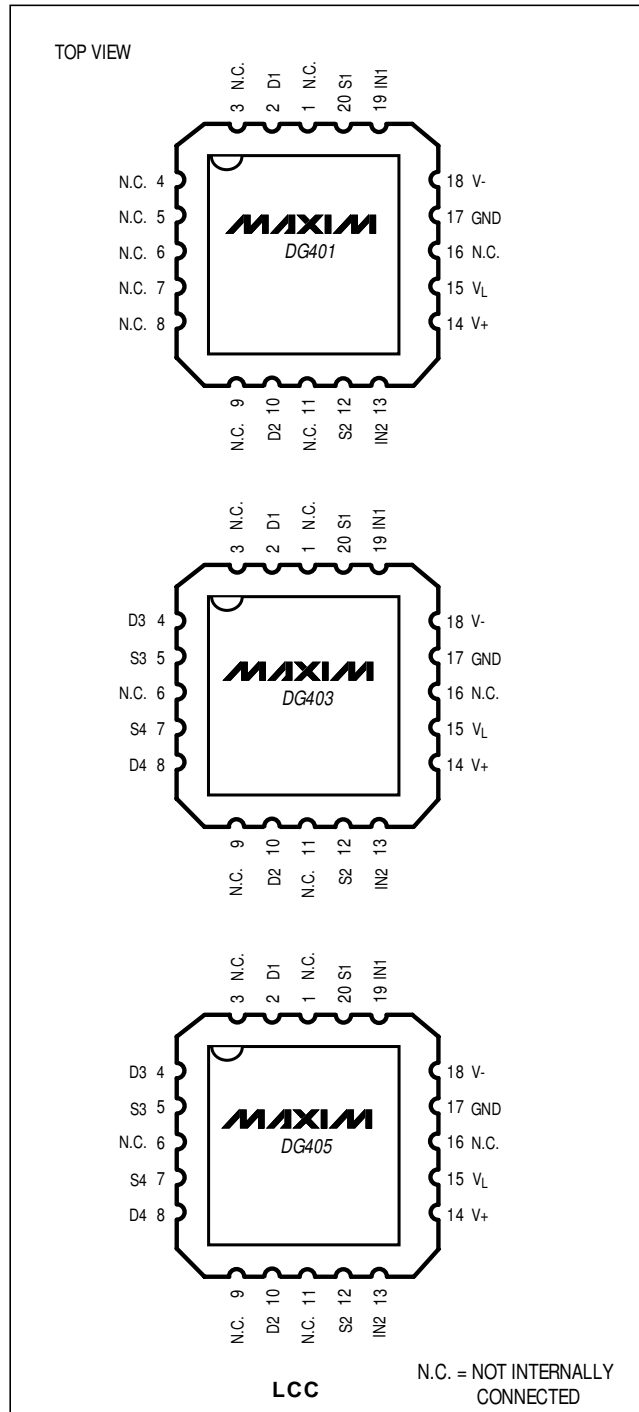

Maxim cannot assume responsibility for use of any circuitry other than circuitry entirely embodied in a Maxim product. No circuit patent licenses are implied. Maxim reserves the right to change the circuitry and specifications without notice at any time.

8 Maxim Integrated Products, 120 San Gabriel Drive, Sunnyvale, CA 94086 408-737-7600