



MSV series

**MSV 400 2V 415AH**

**Valve Regulated Lead Acid Battery**

Maintenance-Free Sealed Lead Acid Battery.

Absorbent Glass Mat (AGM) technology for efficient gas recombination of up to 99%.

**Design for Standby Power Applications**

<p><b>【Design Life】</b> Up to 15 Years in Standby Service at 25°C Eurobat (20°C) : 12 years and longer, Long Life</p> <p><b>【Operating Temperature Range】</b> Nominal Operating Temperature : 25°C (77°F) Discharge : -20°C ~ 50°C (-4°F~122°F) Charge: 0°C ~ 40°C (32°F~104°F) Storage: -20°C ~ 40°C (-4°F~104°F)</p>	<p><b>【Float Charging Voltage】</b> 2.21 ~ 2.25 VDC/Unit at 25°C (77°F)</p> <p><b>【Equalization Charging Voltage】</b> 2.35 VDC/Unit at 25°C (77°F)</p> <p><b>【Self Discharge】</b> Less than 10% after 90 days, can be stored up to 6 months at 25°C (77°F); Fully recharging is required before usage, and charged sooner if stored at higher temperature than 25°C (77°F).</p>
--	--

**Specification**

Nominal Voltage	2V (single cell per unit)		
Nominal Capacity	415 Ah @10hr-rate to 1.80V per cell @25°C (77°F)		
Weight	Approx. 24.90 Kg (54.88 lbs)		
Maximum Discharge Current	2400 A (5sec)		
Internal Resistance	Approx. 0.43 mΩ		
Short Circuit Current	--		
Maximum Charge Current	120 A		
Terminal type	I4 thread copper alloy terminal to accept M8 bolt		
Terminal hardware Torque	414 Kgf-cm / 359 Lbf-in / 40.57 N-m		
Container Material	Flame Retardant ABS (UL 94-V0)		
Dimensions	Depth (D)	197.0±2.0 mm	7.76±0.08 inch
	Width (W)	170.0±2.0 mm	6.69±0.08 inch
	Container height (h)	331.0±2.5 mm	13.03±0.10 inch
	Overall Height (H)	339.0±2.5 mm	13.15±0.10 inch

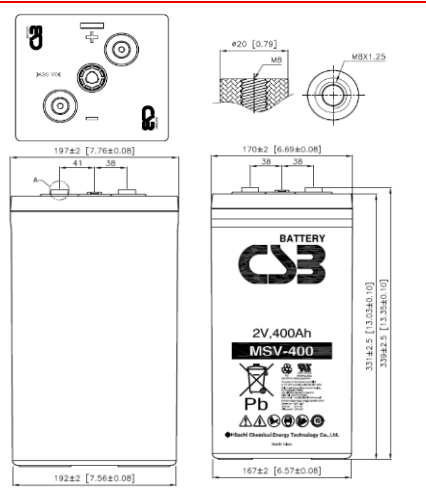

**Constant Current Discharge Characteristics Unit: A (25°C, 77°F)**

F.V/Time	15MIN	30MIN	60MIN	2HR	3HR	4HR	5HR	6HR	8HR	10HR	20HR	24HR
1.60V	586	425	259	158	116	93.3	77.3	66.2	52.0	43.0	21.5	18.0
1.67V	543	399	253	156	115	92.5	76.7	65.8	51.7	42.9	21.4	17.9
1.70V	517	385	248	155	114	92.1	76.4	65.5	51.5	42.7	21.3	17.8
1.75V	476	354	237	152	113	90.7	75.4	64.8	51.0	42.3	21.2	17.6
1.80V	428	313	222	146	109	88.2	73.5	63.3	50.0	41.6	20.8	17.3
1.83V	381	284	211	140	106	85.7	71.5	61.7	48.9	40.8	20.4	17.0

**Constant Power Discharge Characteristics Unit: W (25°C, 77°F)**

F.V/Time	15MIN	30MIN	60MIN	2HR	3HR	4HR	5HR	6HR	8HR	10HR	20HR	24HR
1.60V	884	733	474	292	212	169	142	124	99.2	83.5	41.8	34.8
1.67V	871	701	465	289	210	168	141	123	98.5	83.1	41.6	34.6
1.70V	862	679	458	287	209	167	141	122	98.3	83.0	41.5	34.6
1.75V	842	631	442	282	207	166	140	121	97.8	82.5	41.3	34.4
1.80V	755	566	420	273	203	164	139	120	96.8	81.5	40.8	34.0
1.83V	674	520	402	262	197	161	136	119	95.1	80.2	40.1	33.4

Please refer to the official site for the latest rating confirmation. URL: [www.csb-battery.com](http://www.csb-battery.com)

Issued: 161205

**Sales Offices**

**日立化成能源科技股份有限公司**  
Hitachi Chemical Energy Technology Co., Ltd.

**BUSINESS HEADQUARTERS**

Tel: +886-2-2880-5600  
Fax: +866-2-2888-3300

**USA OFFICE**

Tel: +1-817-244-7777 / 1-(800)3-CSB-USA (272872)  
Fax: +1-817-244-4445

**SHENZHEN OFFICE (CHINA)**

Tel: +86-755-8831-6488, 8831-6775  
Fax: +86-755-8831-6075

**EUROPE (EMEA) OFFICE**

Tel: +31(0)180-418-140  
Fax: +31(0)180-418-327

**SHANGHAI OFFICE (CHINA)**

Tel: +86-21-5046-1622, 5046-0833  
Fax: +86-21-5046-1046

**TAIPEI OFFICE**

Tel: +886-2-2880-5600  
Fax: +866-2-2888-3300

**BEIJING OFFICE (CHINA)**

Tel: +86-10-5820-5336, 5820-5338  
Fax: +86-10-5820-3053

Recognized under UL 1989, and certified by ISO 9001, 14001.

